

EK65

CYLINDER CROWD DRILLING RIG

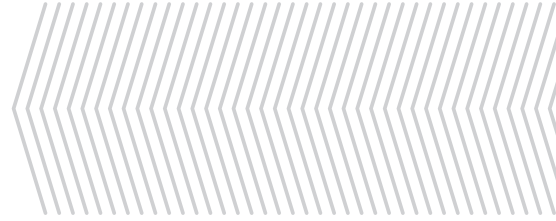

EK65

FEATURES

One load machine with fast and easy set-up.

Kelly bar is transported with the machine, no auxiliary equipment necessary for set up.

Easy conversion from standard to short mast by replacing:

- › **Top mast assembly**
- › **Kelly bar**

CZM'S OPERATOR ASSIST TECHNOLOGY:

- › Auto Gear shifting for Rotary
- › Auto Gear shifting for Main winch
- › Drill Lock
- › Auto Crowd
- › Auto Level
- › Return to Center

TELEMATICS: The rig includes a CZM Telematics System for remote monitoring, diagnostics, and software updates, enabling CZM Support to assist with troubleshooting and performance optimization.

BASE

The new Cat® 317 Next Gen is a purpose-built machine powered by a fuel-efficient U.S. EPA Tier 4 Final C3.6 engine.

Equipped with CAT Vision Link that allows management to monitor machine operations and maintenance data online and wireless, providing information such as location, hours, fuel usage, idle time, event codes and maintenance schedule.

ROTARY

Robust design, with 2 slewing bearings on top and bottom, robust pinion and main gear.

1 group of Hydraulic Motor / Planetary Gears for high torque and long life.

Anti-cavitation and anti-shock system for longer hydraulic motor life.

Cooling system for hydraulic motors and gearboxes.

Power-shift for High spin-off speed (110rpm) for quick discharge of soil.

3 operation speeds and 3 spinoff speeds. For high torque and high speeds.

Automatic gear shifting, for seamless operation, high production.

Exchangeable keys, bolted and reversible. No need to rebuild keys by welding inside the rotary.

Hydraulic measurement of torque displayed in the cab for the operator.

EK65

FEATURES



UNDERCARRIAGE

Variable undercarriage with a telescopic style frame provides increased stability and traction force. Its variable width design expands for maximum stability during drilling and retracts for easy transport.

MAST

Reinforced mast, with high strength steel.

MAIN WINCH

Special groove for better cable winding and longer cable life.

Press roller to maintain cable alignment standard.

2 gears allows for both high speed and high pulling force.

Automatic gear shifting, for seamless operation, high production.

Automatic down the hole winch stop. When Kelly bar reaches the bottom of the hole, winch automatically stops.

CAB

AM/FM Radio, Air conditioning/Heating

Top protection

LCD monitor for Engine and Hydraulics computer, with diagnostic system

CONTROL SYSTEM

Touch Screen Display

Measurements:

- Torque and rotary speeds
- Drilling depth
- Mast inclination X/Y axis
- Main Winch pulling force
- Crowd force

Automatic functions:

- Auto-level of mast
- Rotary automatic gear shifting
- Main Winch automatic gear shifting

Maintenance and data logging



SAFETY

Stability according to EN16228

Base, Mast and Boom Inclinometers

Working radius warning

Limit switches for Boom, Mast Tilt, Main Winch and Service Winch

Operator warnings for non recommended operations.

ACCESSORIES

Lighting package

Refueling pump

O-ring kits

Toolbox

EK65

APPLICATIONS

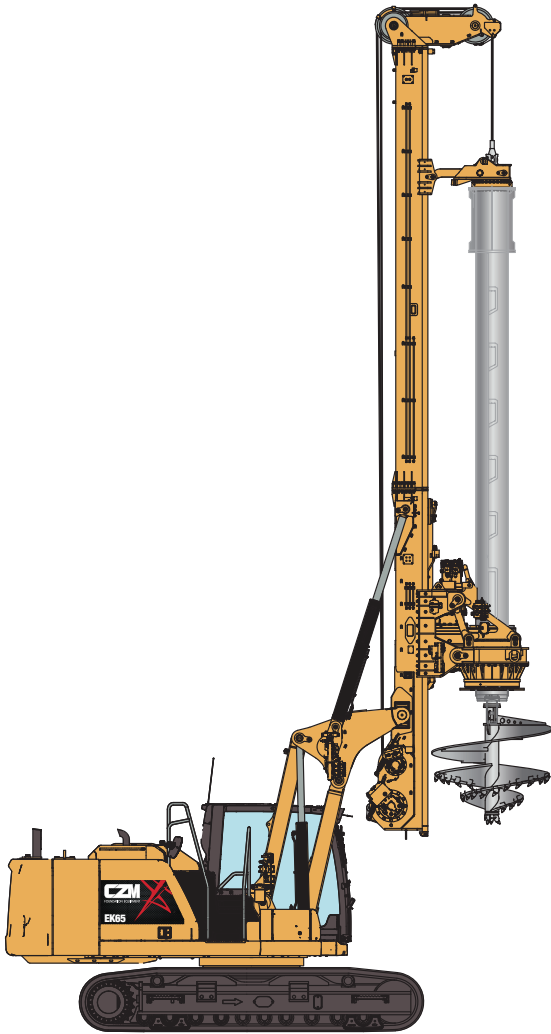

LONG MAST

Standard Drilling Depth	80 ft
Diameter (Max. w/ lower mast)	5 ft
Diameter (Max. w/o lower mast)	8 ft
Max. Torque	77,500 ft.lbs
Operating Weight*	69,500 lb

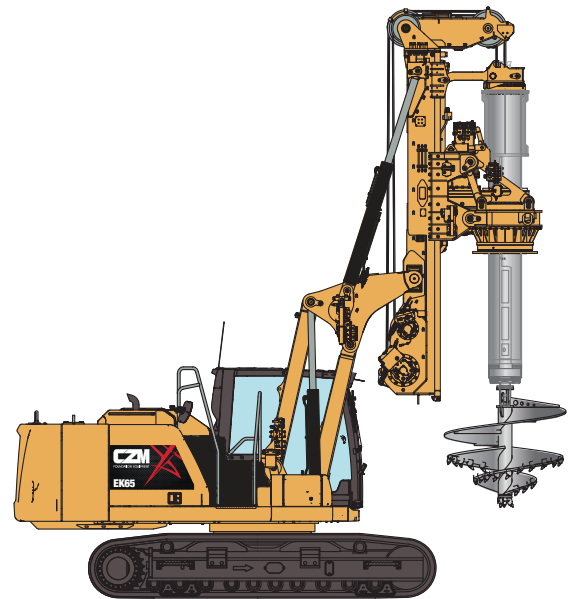

SHORT MAST

Standard Drilling Depth	40 ft
Diameter (Max. w/ lower mast)	5 ft
Diameter (Max. w/o lower mast)	8 ft
Max. Torque	77,500 ft.lbs
Operating Weight*	65,500 lb

*Weight includes standard Kelly, without tool.

EK65

TECHNICAL SPECIFICATIONS

ROTARY HEAD

Maximum torque (Nominal)	77,500 ft.lbs
Working speed of rotation	15-32 rpm
Spin-off rotation	72-110 rpm

CROWD SYSTEM

Cylinder stroke	6 ft 3 in
Cylinder push force	27,000 lbf
Cylinder push speed	75 ft/min
Cylinder pull force	39,600 lbf
Cylinder pull speed	54 ft/min

MAIN WINCH

Max. pull-force - 1st Layer (effective)	27,100 lbf
Max. pull-force - 1st Layer - 2nd Speed (effective)	22,250 lbf
Line speed - 1st Layer	190 ft/min
Max. line speed - 1st Layer - 2nd Speed	230 ft/min
Cable diameter	3/4 in
Drum diameter - 1st Layer	15 in

AUXILARY WINCH

Max. pull-force - 1st Layer (effective)	10,000 lbf
Line speed - 1st Layer	120 ft/min
Cable diameter	5/8 in
Drum diameter - 1st Layer	12.6 in

MAST INCLINATION

Backward	15°
Forward	5°
Sideways	6° / 6°

DIESEL ENGINE Cat® 317 - (C3.6 EPA Tier 4 Final)

Net Power – Standard ISO 14396 (DIN)	136 hp
Displacement	220 in³
Fuel Tank	71.6 gal

HYDRAULIC SYSTEM - (Cat® 317)

Hydraulic pressure	5,076 psi
Flow rate (main circuit)	78 gal/min
Flow rate (auxiliary circuit)	14.3 gal/min
Hydraulic oil tank capacity	23 gal

UNDERCARRIAGE

Track length	14 ft 1 in
Length to Center of rollers	11 ft 8 in
Transport position width (retracted)	8 ft 4 in
Working position width (extended)	12 ft 4 in
Shoes width	23.6 in
Max. drawbar pull	52,200 lbf
Max. travel speed	2.1 mph

*New VG Undercarriage. Fixed Undercarriage available for Short Mast version only.

LONG MAST

GENERAL DIMENSIONS

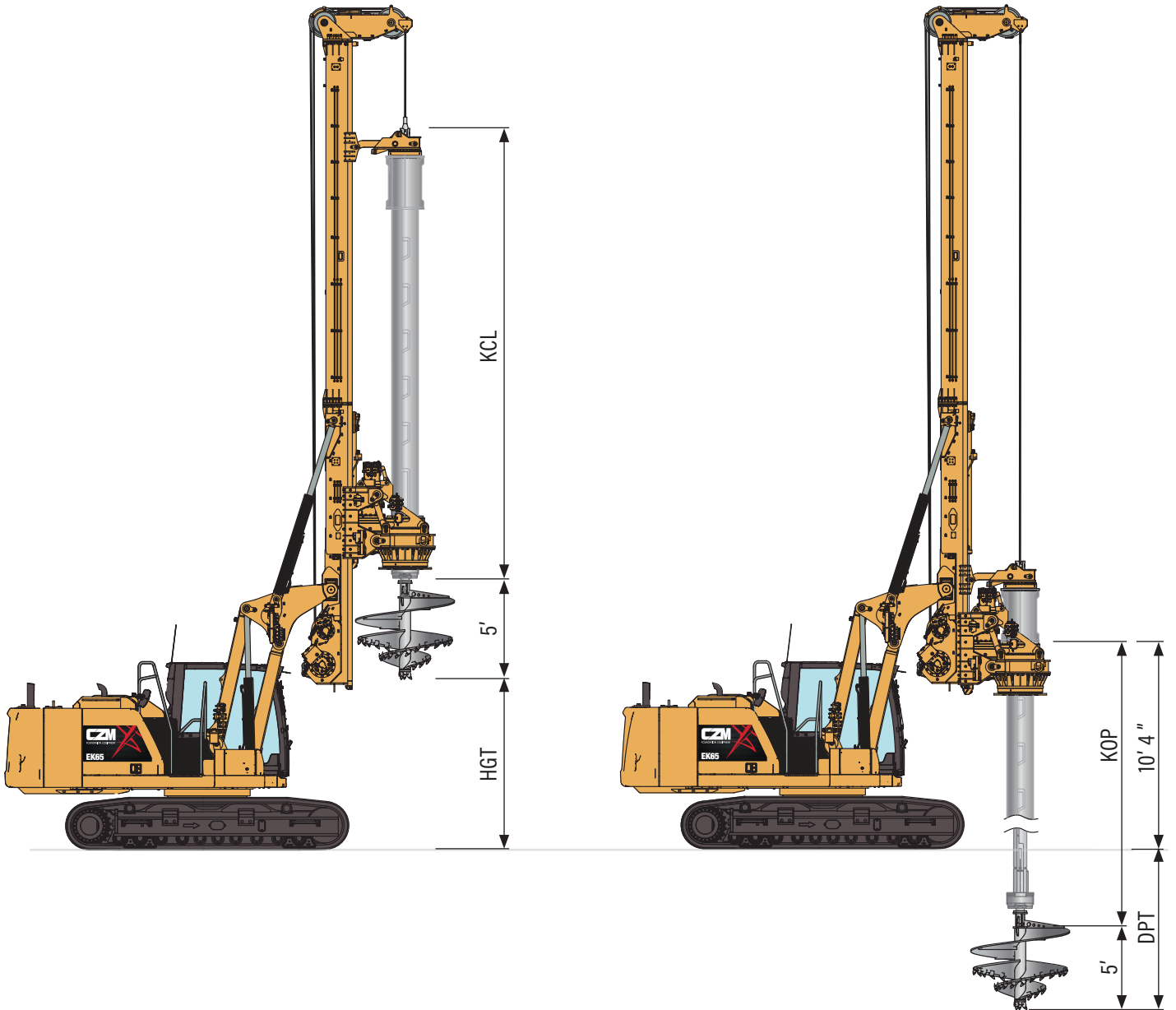

KELLY BAR OPTIONS	PART #	# ELEMENTS	DEPTH - DPT ¹	TRANSPORT - KCL ²	HGT ³	KOP ⁴	WEIGHT ⁵
Standard 5/80 Interlock	20506.5080.000	5	81 ft	22 ft 11 in	8 ft 5 in	87 ft 5 in	9,220 lb

¹ DPT: Total depth with 5ft tool boomed all the way back*. Additional 1.5 ft of depth if boomed forward.

² KCL: Length measured from bottom of stub to top of swivel.

³ HGT: Length measure from ground to bottom of auger assuming a 5ft tall tool.

⁴ KOP: Length measure from top of flange to bottom of stub (without a tool).

⁵ Weight with a-frame and swivel.

Other kelly bars available upon request.

LONG MAST

GENERAL DIMENSIONS

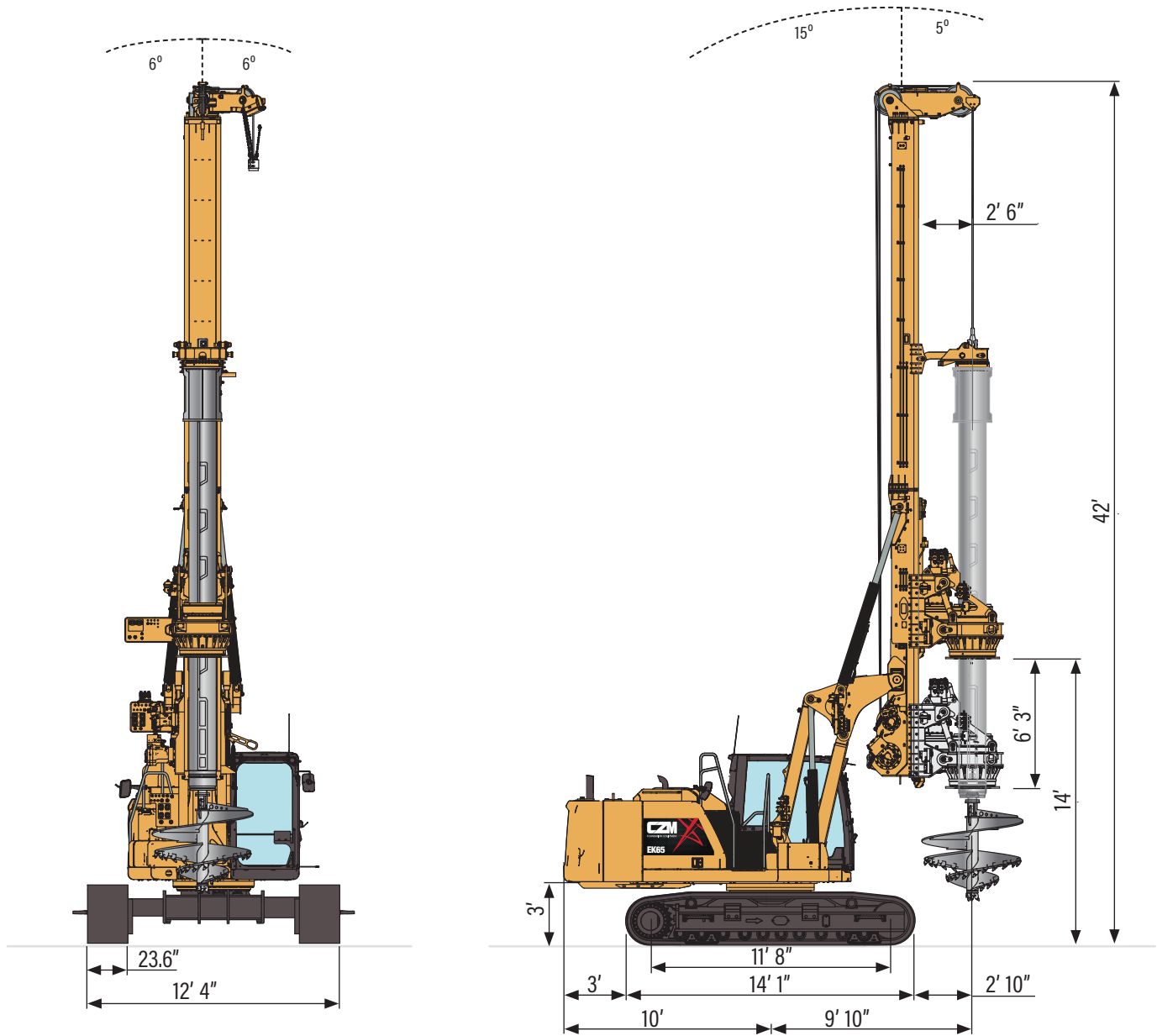

GENERAL SPECIFICATIONS

Maximum torque (Nominal)	77,500 ft.lbs
Crowd force	27,000 lbf
Main winch line pull	27,100 lbf
Cylinder stroke	6 ft 3 in
Operation height	42 ft
Operation weight*	69,500 lbs

*Weight includes standard Kelly, without tool.

SHORT MAST

GENERAL DIMENSIONS

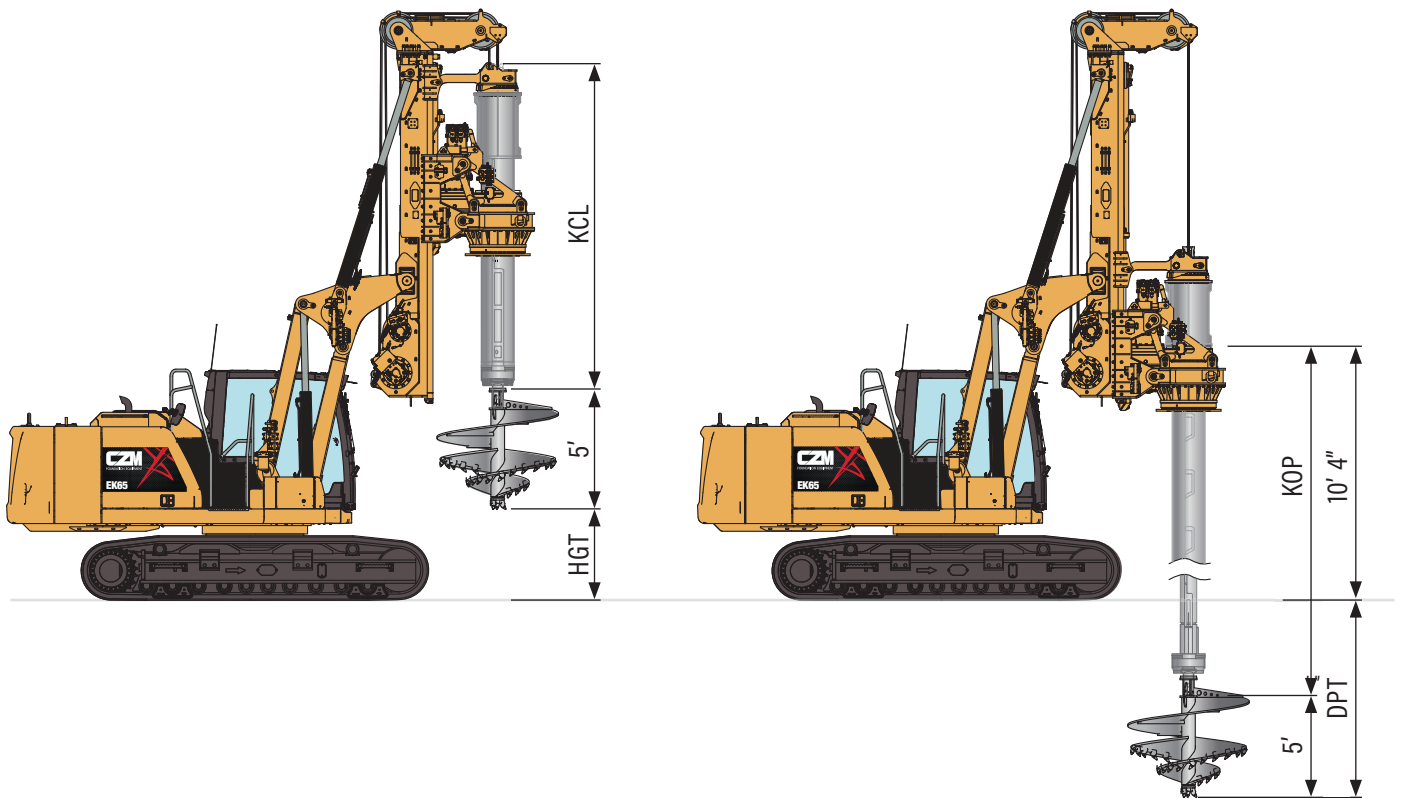

KELLY BAR OPTIONS	PART #	# ELEMENTS	DEPTH - DPT ¹	TRANSPORT - KCL ²	HGT ³	KOP ⁴	WEIGHT ⁵
Standard 5/40 Interlock	20506.5040.000	5	37 ft	13 ft 11 in	3 ft 8 in	43 ft 4 in	5,180 lb
Standard 5/52 Interlock	25862.5052.000	5	50 ft 6 in	17 ft 1 in	6 in	56 ft 10 in	7,010 lb

¹ DPT: Total depth with 5ft tool boomed all the way back*. Additional 3 ft of depth if boomed forward.

² KCL: Length measured from bottom of stub to top of swivel.

³ HGT: Length measure from ground to bottom of auger assuming a 5ft tall tool. More clearance can be reached with mast extension. Standard 5ft mast extension in stock.

⁴ KOP: Length measure from top of flange to bottom of stub (without a tool).

⁵ Weight with a-frame and swivel.

SHORT MAST

GENERAL DIMENSIONS

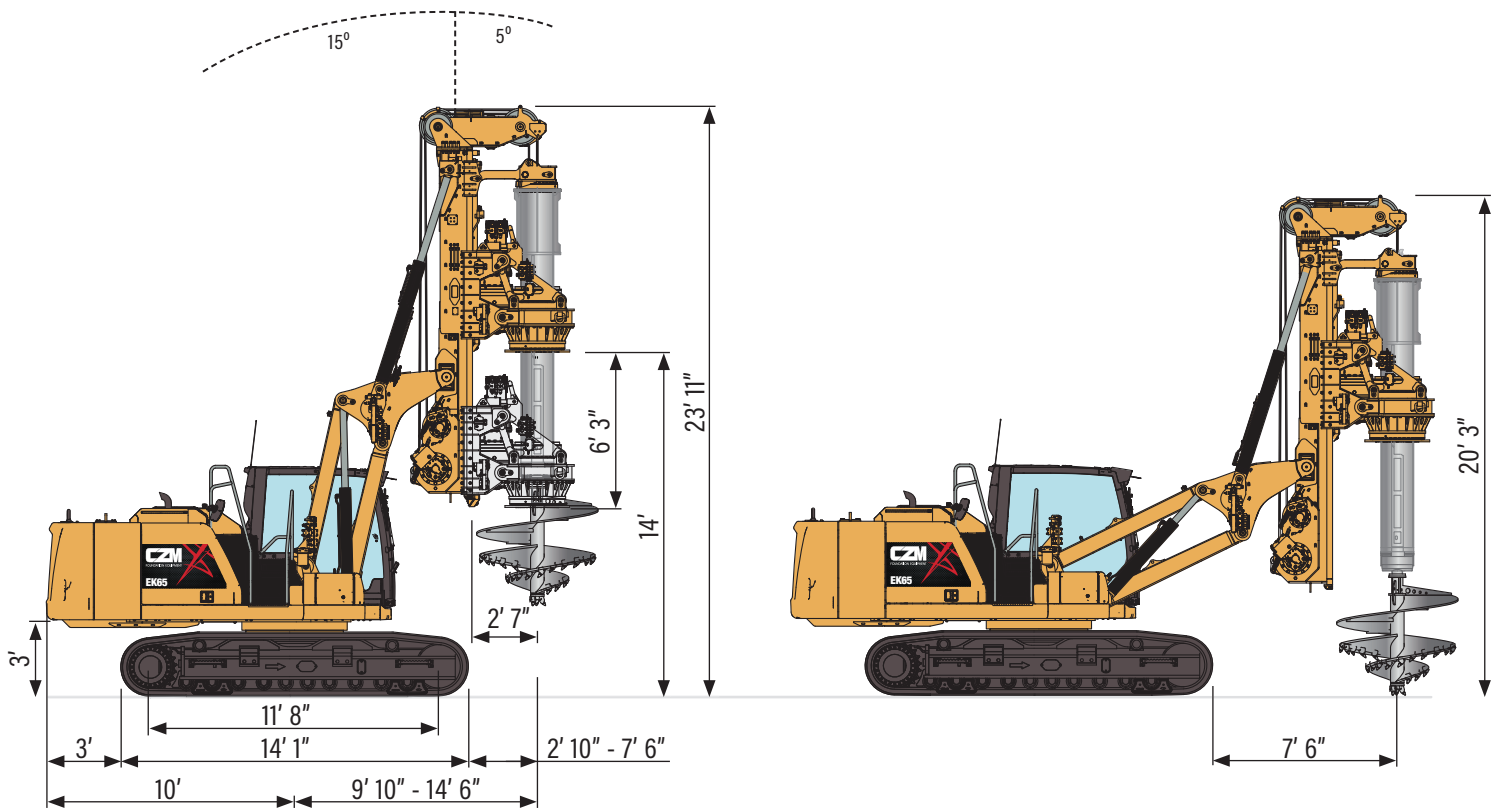

GENERAL SPECIFICATIONS

Maximum torque (Nominal)	77,500 ft.lbs
Crowd force	27,000 lbf
Main winch line pull	27,100 lbf
Cylinder stroke	6 ft 3 in
Operation height	24 ft - 20 ft 3 in
Operation weight*	65,500 lbs

*Weight includes standard Kelly, without tool.



TRANSPORT

DIMENSIONS

LONG MAST

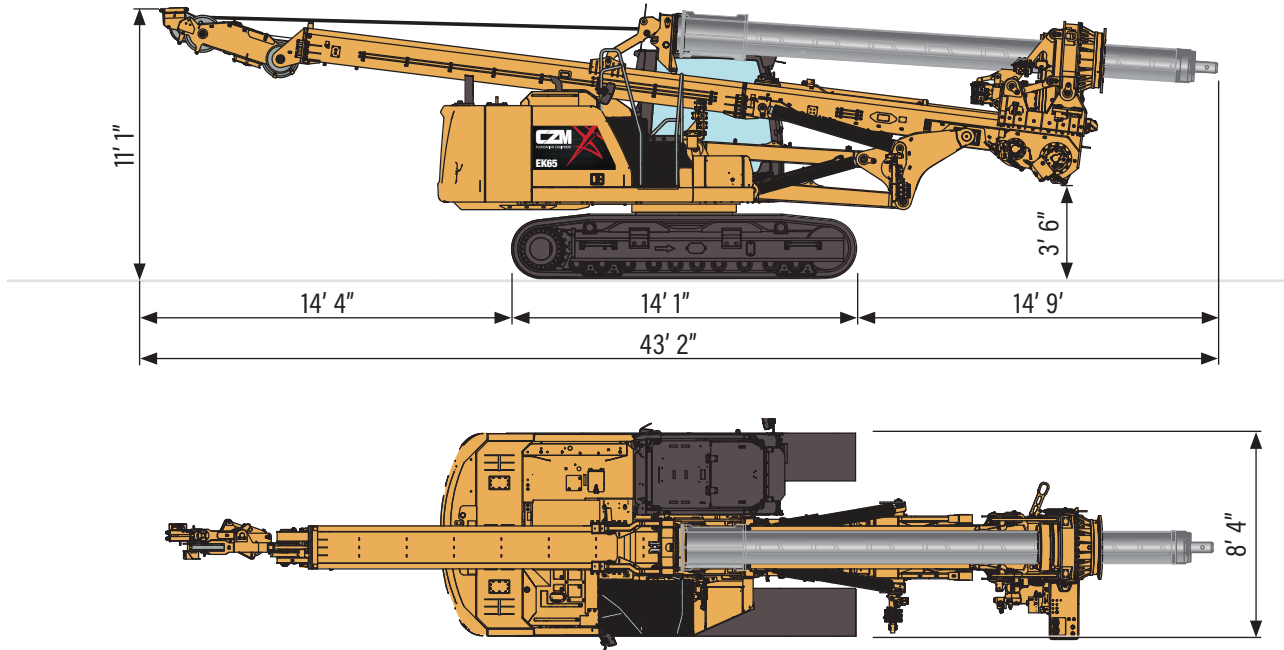

Height	11 ft 1 in
Length	43 ft 2 in
Width	8 ft 4 in
Weight*	69,500 lb

SHORT MAST

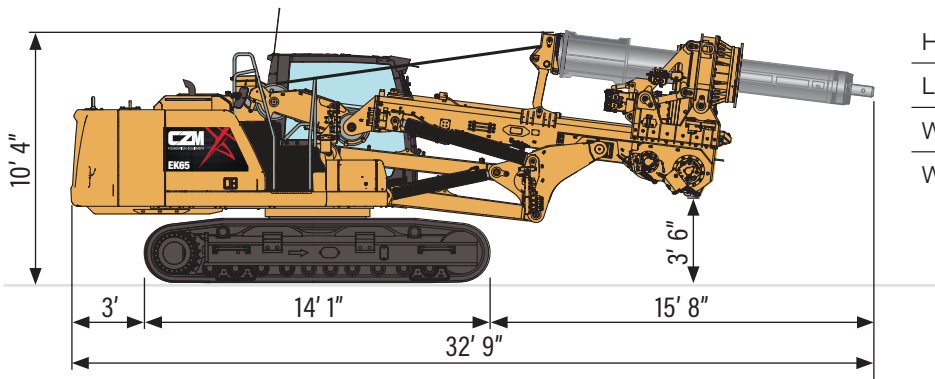

Height	10 ft 4 in
Length	32 ft 9 in
Width	8 ft 4 in
Weight*	65,500 lb

COMPONENTS

Rotary	6,100 lb
Counterweight	8,310 lb

*Weight includes standard Kelly, without tool.



FOUNDATION EQUIPMENT

> HEADQUARTERS

962 Interstate Centre Blvd.
Ellabell, Georgia 31308
(912) 200-7654

czm-us.com



AFTER SALES

> CALIFORNIA

1720 N. Ventura Avenue
Ventura, CA 93001
(805) 701-9885

> GEORGIA

145 East Industrial Blvd.
Pembroke, GA 31321
(912) 200-7656

> KENTUCKY

170 Budco Lane
Elizabethtown, KY 42701
(912) 675-3059

> TEXAS

2501 Blue Mound Rd. W.
Haslet, TX 76052
(817) 232-8053

ABOUT CZM

CZM is headquartered in Savannah, Georgia, USA. For 50 years, we have specialized in manufacturing foundation equipment. We design and customize models for many different drilling applications including Drilled Shafts, CFA, Displacement piles, Soilmixing, Micropiles, Anchors, Driven piles and Soil improvement. We are a Caterpillar OEM (Original Equipment Manufacturer).

myCZM > portal.myczm-us.com

The myCZM Web Portal is the essential digital point of reference for all customers and dealers, providing instant access to everything you need.

- > **Machine Documentation:** Consult manuals, warranties, stability charts, and technical schematics (electrical/hydraulic).
- > **Spare Parts:** Navigate and identify needed parts, and submit direct quotation requests.
- > **Support:** Directly submit information and general inquiries.

CZM CAPITAL

CZM provides flexible, affordable financing to get our machines working for you, Get more than just a machine for your money. Ask us about RPO and lease options.

Contact us today at (877) 773-0333.

> Specifications are subject to change without notice.