

LR95

USE AND MAINTENANCE MANUAL



CZM FOUNDATION EQUIPMENT

HEADQUARTERS

962 Interstate Centre Boulevard
Ellabell, Georgia 31308 United States
Phone: (912) 200-7654

AFTER SALES - GEORGIA

145 East Industrial Boulevard
Pembroke, Georgia 31321 United States
Phone: (912) 200-7656

AFTER SALES - CALIFORNIA

1720 North Ventura Avenue
Ventura, California 93001 United States
Phone: (805) 701-9885

AFTER SALES - TEXAS

2501 Blue Mound Rd. W
Haslet, Texas 76052 United States
Phone: (817) 232-8053

MANUAL VERSION

Manual code:	OM10710.0070
Version:	1.0.0
Publication date:	September, 2024

MACHINE SERIAL NUMBER

Record important machine information below:

Serial Number:	
Year of Manufacture:	

@2024 by CZM USA CORP. All rights reserved. No part of this manual may be reproduced, stored in a filing system, or transmitted to third parties in any form or by any means without CZM USA CORP prior written authorization. CZM USA CORP reserves the right to make changes and improvements to its products at any time and without notice to constantly increase their quality; therefore, this Publication may also be subjected to future changes.

It is forbidden to operate the machine without reading and understanding the contents of this manual.

Special acknowledgment to: M0080149-08 ©2022 Caterpillar All Rights Reserved CAT, CATERPILLAR, their respective logos, "Caterpillar Yellow", the POWER EDGE trade dress, and the corporate and product identity used herein, are trademarks of Caterpillar and may not be used without permission.

* M0080149-08 ©2022 Caterpillar All Rights Reserved

Original instructions in the English language.

SCAN THE QR CODE TO ACCESS CZM WEB PORTAL AND DOWNLOAD YOUR MANUALS.



Table of Contents

Foreword

The Company	Foreword-I
California Proposition 65 Warning	Foreword-I
Warranty Terms	Foreword-I
CZM Products	Foreword-I
The Machines	Foreword-I
The Parts	Foreword-I
Exclusion Clause	Foreword-II
Contact Information	Foreword-II

Introduction

This Operator Manual	1-1
General Description of the Drilling Rig	1-1
Description of the Drilling Rig Components	1-2
Undercarriage	1-4
Counterweights	1-5
Base Machine	1-5
Cab	1-6
Mast	1-7
Main Mast	1-7
Upper Mast	1-7
Articulated Joint	1-7
Mast Inclination	1-7
Head Mast	1-8
A-Frame	1-8
Crowd Cylinder	1-8
Main Winch	1-9
Auxiliary Winch	1-10
Rotary	1-11
Kelly Bar	1-12
Hydraulic Components	1-13
Electrical Components	1-15
Description of Symbols	1-17

Safety

General Safety	2-1
Hazard Alerts in This Manual	2-1
Operator Safety Information	2-1
Personnel	2-2
Machine Operator	2-2
Operator Assistant	2-2
CZM Technician	2-2
Specialized Technician	2-2
Signal Person and Hand Signals	2-3
Personal Protective Equipment (PPE)	2-3
Safety Messages*	2-4
Safety Decals	2-5
Crushing Hazard* (1)	2-9
Product Link* (2)	2-9

Do Not Operate* (3)	2-9
Seat Belt* (4)	2-9
Crushing Hazard* (5)	2-10
Electrical Power Lines* (6)	2-10
Do Not Weld or Drill on ROPS* (7)	2-10
Front Window Usage* (8)	2-11
Data Privacy* (9)	2-11
Alternate Exit* (10)	2-11
Falling Object Guard Structure* (11)	2-11
Hot Surface* (12)	2-11
Crushing Hazard* (13)	2-12
Aerosol Starting Aid* (14)	2-12
Jump-Start Cables* (15)	2-12
Crush Hazard* (16)	2-12
High-Pressure Gas* (17)	2-13
Vapor Explosion* (18)	2-13
Relieve Hydraulic Tank Pressure* (19)	2-13
Additional Safety Decals	2-14
No Step* (1)	2-14
DEF Purge Indicator Lamp* (2)	2-14
Air Conditioner* (3 A–H)	2-15
Engine Oil Requirements* (4)	2-15
Diesel Fuel Requirements* (5)	2-16
Hydraulic Oil Level Check* (6)	2-16
Hazard Prevention	2-17
Health and First Aid	2-17
Contact with Fluids	2-17
Electrocution	2-17
Lines, Tubes, and Hoses*	2-18
Pressurized Hydraulic Oil Lines	2-18
High-Pressure Fuel Lines*	2-19
Accumulator Safety	2-20
Track*	2-20
Pressurized Air and Water*	2-20
Trapped Pressure*	2-20
Fluid Penetration*	2-20
Containing Fluid Spillage*	2-21
Inhalation	2-21
Exhaust	2-21
Asbestos	2-21
Crushing Prevention and Cutting Prevention*	2-22
Burn Prevention*	2-22
Coolant*	2-22
Oils*	2-22
Battery Safety	2-23
Batteries*	2-23
Battery Disposal	2-23
Fire Prevention and Explosion Prevention*	2-23
Regeneration*	2-23
General Maintenance Safety*	2-24
Fueling*	2-25

Fuel Tank / Vapor	2-25
Electrical System Maintenance	2-26
Electrical System Cleaning	2-26
Disconnect the Battery	2-26
Battery and Battery Cables*	2-26
Wiring*	2-27
Ether*	2-28
Fire Safety*	2-28
Fire Extinguisher Location*	2-28
In Case of Fire	2-28
Electrical Storm Injury Prevention*	2-29
Snow and Ice	2-29
Dust	2-29
Chemicals	2-29
Suspended Loads	2-29
Work Area	2-30
General Rules	2-30
Above Ground Hazards	2-30
Precautions in High-Voltage Areas	2-30
United States Safe Distances for Power Lines	2-30
Underground Hazards	2-30
Soil Conditions	2-31
Soil Classification	2-32
Soil Subsidence	2-32
Slopes and Ditches	2-33
Operation and Use of the Drilling Rig	2-33
Access to the Drilling Rig	2-33
Workplace	2-34
Emergency Exit	2-34
Alternate Exit	2-34
Rear Window with Ring Seal (If Equipped)*	2-34
Rear Window with Lever (If Equipped)*	2-35
Guards	2-35
Before Starting Engine*	2-36
Engine Starting*	2-36
Before Operation (Engine Started)*	2-36
Machine Safety	2-37
Danger Zone	2-37
Signal Person and Hand Signals	2-37
Machine Parking	2-38
Wind Speed	2-38
Authorized Use of This Drilling Rig	2-38
Unauthorized Use of This Drilling Rig	2-38
Unauthorized Modifications	2-38
Fire Safety	2-38
Transportation and Lifting Safety	2-39
Transportation	2-39
Lifting the Drilling Rig/Base Machine	2-39
Job Site Safety	2-40
Inclination Limits / Mast Positioning	2-41
Drilling Rig Stability and Ground Pressure	2-42

Unstable or Uneven Terrain	2-42
Traveling Up Hill	2-43
Traveling Down Hill	2-43
Traversing Slopes Safely	2-44
Swing Operation Safety	2-44
Mast Raising/Lowering Safety	2-45
Auxiliary Winch Safety	2-46
Open Hole Safety	2-47
Spin-Off Safety Zone	2-47
Kelly Bar and Auger Safety	2-48
Barge Safety	2-49
Traffic Operation Safety	2-49
Environmental Precautions	2-49
Temperature Indications	2-49
Maintenance Safety	2-50
Environment	2-50
Safety Rules	2-51
Lockout/Tagout Procedure	2-51
Cleaning the Drilling Rig	2-51
Critical Failures*	2-52

Stability

Stability Conditions	3-1
Stability Calculation Method	3-1
Short Mast	3-2
Traveling Stability – Forward Facing	3-2
Traveling Stability – Off the Side	3-3
Drilling Stability – Forward Facing	3-4
Drilling Stability – Off the Side	3-5
Auxiliary Winch Stability – Forward Facing	3-6
Auxiliary Winch Stability – Off the Side	3-7
Long Mast	3-8
Traveling Stability – Forward Facing	3-8
Traveling Stability – Off the Side	3-9
Drilling Stability – Forward Facing	3-10
Drilling Stability – Off the Side	3-11
Auxiliary Winch Stability – Forward Facing	3-12
Auxiliary Winch Stability – Off the Side	3-13

Technical Specifications

Drilling Rig Specifications	4-1
Kelly Bar Short Mast Application	4-1
Rotary Head – RT 406 - 10 (Standard)	4-1
Crowd System	4-1
Mast Inclination	4-1
Main Winch	4-1
Auxiliary Winch	4-1
Diesel Engine CAT®330 Next Gen Tier IV (CAT® C7.1 ACERT™)	4-2
Hydraulic System	4-2
Undercarriage	4-2
Transport	4-2

Short Mast General Data	4-2
Long Mast General Data	4-2
LR95 Kelly Bar Options	4-3
Rotary Head Dimensions	4-4
Torque Diagrams	4-5

General Dimensions

Working Position Short Mast (Boom Up)	5-1
Working Position Short Mast (Boom Forward)	5-2
Transport Position Short Mast	5-2
Working Position Long Mast (Boom Up)	5-3
Working Position Long Mast (Boom Forward)	5-4
Transport Position Long Mast	5-4
Mast Tilting	5-5

Controls

Controls Overview	6-1
Battery Disconnect Switch*	6-2
Cab Overview	6-3
Operator Seat*	6-4
Adjustment and Operation	6-4
Lumbar Controls	6-5
Seat Belt	6-6
Fastening The Seat Belt	6-6
Releasing The Seat Belt	6-6
Extension of the Seat Belt	6-6
Hydraulic Lockout Control*	6-7
Engine Start Switch*	6-7
Travel Controls	6-8
Function Levers	6-9
Joysticks	6-10
Left Joystick	6-10
Right Joystick	6-11
Right Side Switch Panel*	6-12
Main and Auxiliary Pump Gauges	6-14
CZM Monitor	6-14
Initial Screen	6-14
Home Screen	6-15
Home Screen Switch Functions	6-16
Home Screen Machine Settings	6-18
Machine Setting Options	6-18
Second Screen	6-19
Second Screen Switch Functions	6-19
Switch Icon Colors	6-19
L1 – Main Winch Limit and Exclusion Switch	6-20
L2 – Auxiliary Winch Limit and Exclusion Switch	6-20
L3 – Main Winch Bottom-Hole Exclusion Switch	6-21
R1 – Mast Lock (If Equipped) Switch	6-21
Second Screen Machine Setup Functions	6-22
Machine Setup Options	6-22
Third Screen	6-23

Third Screen – Page 1 Switch Functions	6-23
Third Screen – Page 2	6-24
Third Screen – Page 2 Switch Functions	6-24
Mast Level Calibration Screen	6-25
Mast Level Calibration Option Settings	6-25
Change Password Screens	6-25
Complete Maintenance Screen	6-26
Settings Screen	6-27
Active Faults Screens	6-28
Active Fault Indications	6-28
Active Fault Display Screen	6-28
CAT® Monitoring System*	6-29
General Information*	6-29
Action Lamps (1)	6-30
Status Information Area (2)*	6-30
Notification Center Icon (3)*	6-31
Camera View (4)*	6-31
Gauge Area (5)*	6-32
Navigation Bar (6)*	6-32
Machine Warnings*	6-33
Event Indicator Area	6-33
Logging In*	6-33
Navigation*	6-33
Radio*	6-34
Radio Function List*	6-36
Selection Method*	6-36
Radio Operation*	6-37
USB/AUX Operation*	6-37
Air Conditioning and Heating Control*	6-38
Selection Method*	6-40
Operation*	6-40
Operator Screen*	6-41
Application Menu*	6-41
Setting Menu*	6-42
Display Setting*	6-43
Clock Adjust*	6-44
Time Zone*	6-44
Brightness Adjust*	6-45
Display Unit Select*	6-45
Default Camera View*	6-46
Language Select*	6-46
Information*	6-47
Performance*	6-48
Current Totals*	6-48
License Information*	6-49
ECM Summary*	6-49
Diagnostics*	6-50
Machine Setting*	6-50
Engine Shutdown Setting*	6-51
Power Mode Setting*	6-52
Reverse Fan (If Equipped)*	6-52

Reverse Fan - Auto Mode*	6-53
Audio*	6-54
Lighting Shutdown Timer*	6-55
Auto Warm Up*	6-55
Sleep Time*	6-56
Security*	6-57
Operator Setting*	6-57
Automatic Engine Speed Control (AEC)	6-61
Heavy Lift*	6-62

Operation

Operating Safely	7-1
Daily Inspections	7-1
Mounting and Dismounting	7-1
Cab Operation	7-1
Cab Door*	7-1
Window (Front)*	7-2
Alternate Exit*	7-3
Rear Window with Ring Seal (If Equipped)*	7-3
Rear Window with Lever (If Equipped)*	7-3
Roof Hatch*	7-4
Sun Screen*	7-5
Dome Light*	7-5
Product Link*	7-5
Visibility	7-6
Mirrors*	7-6
Mirror Adjustment	7-6
Right Side View Mirror on the Cab (1)*	7-7
Left Side View Mirror on the Cab (4)*	7-7
Tank Mirror (3)*	7-8
Cameras*	7-8
Rear View Camera	7-8
Side View Camera (If Equipped)*	7-9
360 Visibility (If Equipped)*	7-9
Fuel Transfer Pump (Refueling) (If Equipped)*	7-10
Fuel Tank Shutoff and Drain Control*	7-11
Engine Fuel Shutoff Valve	7-11
Operation Information*	7-12
Undercarriage	7-12
Traveling	7-12
Base Swinging	7-12
Winches	7-13
Main Winch	7-13
Auxiliary Winch	7-13
Starting the Machine	7-14
Selective Catalytic Reduction Warning System*	7-14
Definitions	7-14
Inducement Strategy for DEF Level*	7-14
Inducement Strategy for DEF Quality, Tampering, SCR System Fault, and Impeded EGR*	7-16
Machine Security System*	7-17
General Information*	7-17

Components*	7-17
System Overview*	7-18
Activating Bluetooth Functionality*	7-18
Pairing Your Device to the Machine*	7-19
Reading the ID of a Key*	7-19
Armed*	7-19
Disarmed*	7-20
Grace Period*	7-20
Navigating the User Interface Touchscreen Display*	7-20
Operation of Status Indicator*	7-21
Operator Login*	7-22
Passcode Entry*	7-22
Invalid Passcode*	7-23
Bypass login*	7-23
Bluetooth Entry*	7-24
CAT® Fleet Management Mobile Application*	7-25
Mobile Application Entry (Android Devices)*	7-26
Mobile Application Entry (iOS Devices)*	7-29
Engine Starting*	7-32
Engine Start Switch Troubleshooting*	7-34
Engine and Machine Warm-Up*	7-35
Hydraulic System	7-35
Automatic Warm-Up*	7-35
Manual Warm-Up*	7-36
Improve Cold-Weather Performance*	7-36
Recommendation for Crankcase Breather Protection (Machines with C4.4 and C7.1)*	7-37
Installation*	7-37
Machine Setup for Drilling	7-38
Forward and Reverse Travel	7-38
Turning	7-38
Slopes	7-39
Drilling Operations	7-40
Standard Drilling	7-40
Automatic Drilling Functions	7-42
Auto Drill (Drill Lock)	7-42
Auto Crowd	7-42
Auto Mast Level	7-43
Return to Center	7-43
Rotary Autoshift	7-44
Main Winch Autoshift	7-44
Auto Power-Shift (Spin-Off)	7-45
Overcrowd Protection System	7-45
Bottom-Hole System	7-45
Drilling On Rock (Boulders)	7-46
Drilling on Slurry/Polymer or Bentonite	7-46
Installing a Casing	7-47
Installing J-Lock Casing	7-47
Parking*	7-48
Stopping the Machine*	7-48
Stopping the Engine*	7-48
Engine Shutdown Switch*	7-48

Stop the Engine if an Electrical Malfunction Occurs*	7-49
Parking	7-50
Leaving the Machine*	7-50
Machine Storage	7-50
Decommissioning and Disposal*	7-50

Machine Setup for Drilling

Unload the Machine	8-1
Machine Setup Steps	8-1
Extend the Undercarriage Tracks	8-2
Place the Mast in the Work Position	8-3
Attach the Work Tool	8-3

Loading Machine for Transport

Machine Setup Steps	9-1
Disconnect the Work Tool	9-1
Place the Mast in the Transport Position	9-2
Retract the Undercarriage	9-3
Shipping the Machine*	9-3
Securing the Machine*	9-4
Tying Down the Machine*	9-5
Frictional and Direct Lashing*	9-6
Diagonal Lashing*	9-7

Service Recommendations

Maintenance Recommendations	10-1
Welding on Machines and Engines with Electronic Controls*	10-2
Severe Service Application*	10-2
Severe Environmental Factors*	10-2
Severe Operating Conditions*	10-2
Improper Maintenance Procedures*	10-3
Access Door and Cover Locations	10-3
Engine Hood*	10-3
Engine Service Door*	10-4
Left Rear Access Door*	10-4
Left Front Access Door*	10-4
Right Side Access Door*	10-5
Right Front Access Door	10-5
Prepare the Machine for Maintenance*	10-5
Maintenance Plan	10-7
Fluids and Lubricants	10-11
Lubricating The Machine	10-13
Wire Rope Maintenance	10-19
Inspect the Wire Rope	10-19
Lubricate the Wire Rope	10-19
Replace the Winch Wire Rope	10-19
Apply Wire Rope Tension	10-20
After Installation of a New Rope	10-20
Main Winch Maintenance	10-20
Check/Add Main Winch Oil	10-20
Check Main Winch Reducer/Brake Oil Level	10-20

Add Main Winch Reducer/Brake Oil	10-21
Drain and Refill Main Winch Reducer/Brake Oil	10-21
Auxiliary Winch Maintenance	10-22
Check/Add Auxiliary Winch Oil	10-22
Check Auxiliary Winch Reducer/Brake Oil Level	10-22
Add Auxiliary Winch Reducer/Brake Oil	10-22
Drain and Refill Auxiliary Winch Reducer/Brake Oil	10-23
Rotary Drive Maintenance	10-23
Check/Add Rotary Drive Reducer Oil	10-23
Check Rotary Head Reducer Oil Level	10-23
Add Rotary Head Reducer Oil	10-24
Drain and Refill Rotary Head Reducer Oil	10-25
Check/Add Rotary Gearbox Oil	10-26
Check Rotary Gearbox Oil	10-26
Add Rotary Gearbox Oil	10-26
Drain and Refill Rotary Gearbox Oil	10-27
Kelly Bar Installation And Removal	10-28
Kelly Bar Removal	10-28
Kelly Bar Installation	10-29
Rotary Head Remove And Install	10-30
Rotary Head Removal	10-30
Rotary Head Installation	10-32
A-frame Remove And Install	10-34
A-frame Removal	10-34
A-frame Installation	10-35
Swivel Remove And Install	10-36
Swivel Removal	10-36
Swivel Installation	10-36
Rotary Sled Wear Pad Maintenance	10-36
Wear Pad Removal	10-36
Wear Pad Installation	10-36
Adjusting the Rotary Sled Wear Pads	10-37
Replace A-frame Wear Pads	10-37
Counterweight Remove and Install	10-38
Counterweight Removal	10-38
Counterweight Installation	10-39
Engine Maintenance	10-41
Engine Oil Level – Check*	10-41
Engine Dipstick*	10-41
Ground Level Dipstick*	10-42
Engine Oil Sample – Obtain*	10-42
Engine Oil and Filter – Change*	10-42
Selection of the Oil Change Interval	10-42
Changing the Engine Oil and Filter*	10-43
Fast Fill (If Equipped)*	10-45
Engine Air Filter Primary and/ or Secondary Element – Replace*	10-45
Primary Air Filter Element – Replace*	10-46
Secondary Air Filter Element – Replace*	10-47
Engine Air Pre-Cleaner – Clean*	10-48
Fumes Disposal Filter Element – Replace*	10-49
Cooling System Coolant (ELC) – Change*	10-50

Cooling System Coolant Extender (ELC) – Add*	10-52
Cooling System Coolant Level – Check*	10-53
Cooling System Coolant Sample (Level 1) – Obtain*	10-53
Cooling System Coolant Sample (Level 2) – Obtain*	10-55
Belt - Inspect/Adjust/Replace*	10-55
Ether Starting Aid Cylinder (If Equipped)*	10-55
Radiator, Aftercooler and Oil Cooler Cores – Clean*	10-56
Fuel System	10-57
Fuel Cap Filter – Replace*	10-57
Fuel System – Prime*	10-57
Fuel System Primary Filter (Water Separator) Element – Replace	10-58
Fuel System Secondary Filter – Replace*	10-59
Fuel System Water Separator – Drain*	10-60
Fuel Tank Strainer – Clean*	10-60
Fuel Tank Water and Sediment – Drain*	10-61
Diesel Exhaust Fluid (DEF)	10-61
Diesel Exhaust Fluid Filler Screen – Clean*	10-61
Diesel Exhaust Fluid Filter Manifold Filters – Replace*	10-62
Diesel Exhaust Fluid – Drain*	10-62
Diesel Exhaust Fluid – Fill*	10-63
Diesel Exhaust Fluid Filter – Replace*	10-64
Diesel Exhaust Fluid Injector – Replace*	10-65
Hydraulic System	10-66
Release of Hydraulic Pressure from the Main Hydraulic System*	10-66
Hydraulic System Oil – Drain*	10-67
Hydraulic Tank Screen – Clean*	10-69
Case Drain Filter – Clean*	10-71
Hydraulic System Oil – Fill and Purge Air	10-71
Hydraulic System Oil Filter (Return) – Replace*	10-73
Hydraulic System Oil Level – Check*	10-74
Hydraulic System Oil Sample – Obtain*	10-76
Indicators and Gauges – Test*	10-76
Oil Filter – Inspect*	10-77
Inspect a Used Filter for Debris*	10-77
Return Line Filter Replacement	10-77
Replacing the Return Filter Elements	10-77
Electrical System	10-78
Battery – Clean*	10-78
Battery Electrolyte Level – Check*	10-78
Battery Hold-Down – Tighten*	10-78
Battery or Battery Cable – Inspect/Replace*	10-78
Recycle the Battery	10-79
Recycling facility	10-79
Camera – Clean*	10-79
Fuses – Replace*	10-80
Fuse Identification*	10-81
Relay Identification	10-82
Power Fuse Module*	10-83
Secondary Power Fuse Module – 323 Tier 4 Only*	10-83
High Intensity Discharge Lamp (HID) – Replace (If Equipped)*	10-84
Cab	10-85

Air Conditioner/Cab Heater Filter (Recirculation) – Inspect/Replace*	10-85
Condenser (Refrigerant) – Clean*	10-85
Receiver Dryer (Refrigerant) – Replace*	10-86
Cab Air Filter (Fresh Air) – Clean/Replace*	10-86
Rollover Protective Structure (ROPS) – Inspect*	10-87
Seat Belt – Inspect*	10-87
Seat Belt – Replace*	10-88
Windows – Clean*	10-88
Cleaning Methods*	10-88
Window Washer Reservoir – Fill*	10-89
Window Wiper – Inspect/ Replace*	10-89
Decal (Product Identification) – Clean	10-89
Cleaning of the Decals	10-89
Swing Maintenance	10-90
Swing Bearing – Lubricate*	10-90
Swing Drive Oil – Change*	10-90
Swing Drive Oil Level – Check*	10-92
Swing Drive Oil Sample – Obtain*	10-92
Swing Gear – Lubricate*	10-93
Undercarriage	10-94
Undercarriage – Check*	10-94
Travel Alarm – Test*	10-94
Track Adjustment – Adjust*	10-95
Measuring Track Tension*	10-95
Adjusting Track Tension*	10-96
Track Adjustment – Inspect*	10-97
Final Drive	10-97
Final Drive Oil – Change*	10-97
Final Drive Oil Level – Check*	10-98
Final Drive Oil Sample – Obtain*	10-99
Torque Specifications	10-99
Torque Table	10-101
Torque Marking – Basic Process	10-102
Torque Marking – Circular Process	10-102
Torque-Turn	10-103
O-Ring Specifications	10-104
Hydraulic Pressure Specifications	10-105
Hydraulic and Electrical Schematics	10-105

The Company

CZM is headquartered in Savannah, Georgia, USA. For more than 40 years, we have specialized in manufacturing foundation equipment. We design and customize models for many different drilling applications, including drill shafts, CFA/Cased CFA, micropile, anchoring, piled-drive and hydraulic hammers, and soil improvements. We are a Caterpillar OEM (Original Equipment Manufacturer).

IMPORTANT: Keep this manual in a well-known and easily accessible place throughout the working life of the machine.

California Proposition 65 Warning

Diesel engine exhaust and some of its constituents are known to the State of California to cause cancer, birth defects, and other reproductive harm.

WARNING

This product can expose you to chemicals including ethylene glycol, which is known to the State of California to cause birth defects or other reproductive harm. For more information go to:

www.P65Warnings.ca.gov

Do not ingest this chemical. Wash hands after handling to avoid incidental ingestion.

WARNING

This product can expose you to chemicals including lead and lead compounds, which are known to the State of California to cause cancer, birth defects, or other reproductive harm. For more information go to:

www.P65Warnings.ca.gov

Wash hands after handling components that may contain lead.

Warranty Terms

CZM Products

CZM USA CORP, manufacturer of the equipment and tools branded CZM, ensures the products sold against defects through its After Sales department. The warranty applies as below.

The Machines

The After Sales department or authorized dealer will service, repair, or replace any part or product that, according to technical analysis, fails by defect in material or workmanship. The workplace could be in a CZM branch, or in the machine's current location, if possible. The After Sales department will provide the labor for service needed at no cost to the user during the following periods after the date of delivery to the user:

- 12 (twelve) months: In the case of hydraulic motors, gearboxes, rotary transmission, axles, hydraulic components, and structure components.
- 6 (six) months: For others items, considered as wear parts, including sealing components.

The Warranty Terms are subjected to the execution of all the Maintenance Procedures described in the Operation and Maintenance Manual, as well as commissioning, performed by trained technicians designated by the manufacturer.

The Parts

The After Sales department or authorized dealer will fix or repair any part that, according to technical analysis, fails by defect in material or workmanship.

The workplace could be in a CZM branch, or in the machines location, if possible. The After Sales department will provide the labor for service as needed at no cost to the user during the following periods after the date of delivery to the user:

- 3 (three) months: From the date of issue of invoice, if the user takes the responsibility of assembling the part;
- 6 (six) months: From the date of issuance of the Order of Service concerning the intervention, if the assembly is performed by an authorized service professional.

FOREWORD

The expenses for transport of equipment or its components to the establishment of the manufacturer or authorized dealer are not included in the Warranty Terms. If the user chooses set-up in others places, the Warranty Terms do not include traveling expenses for service technicians.

In this case, the After Sales department must submit a quote of these values for customer approval.

Exclusion Clause

The Warranty Terms do not apply in cases where:

- Operation or improper maintenance, negligence, inability or accident, the use of implements and/or parts not approved by CZM and/or the use of lubricants and oils not listed as determined by technical analysis.
- Products are operated over the capacity it was designed for and/or recommended by the manufacturer.
- The products are modified or repaired in a way not authorized by CZM.
- The products whose preventive maintenance and inspections are not performed in accordance with the specifications contained in Operating and Maintenance Manual.
- The components have warranty coverage with their respective manufacturers, such as excavator chassis, fuel injection components, diesel engines, etc.
- Does not cover economic losses due to nonoperational machine or rented equipment costs.
- If these are normal wear parts such as brake discs, wear plates, pins, lubricated joints (pins and bushings), or any parts that wear out due to contact with soil, oil, lubricants, filters, exhausts, and associated parts (injector nozzles, adjusters, straps, lenses, lamps, and fuses).
- Kelly bars wear with use and are extremely susceptible to damage due to operator error. This component will not be warranted unless failure is deemed to be from manufacturing non-conformity.

The responsibility of CZM or authorized dealer due Warranty Terms, or by civil contract or a result of warranties, declarations, instructions, or effects of any kind, shall be limited to repair or delivery parts, under the conditions mentioned in the Warranty Terms.

The CZM USA CORP reserves the right at any time to revise, modify, or discontinue any products without incurring in carrying out the update on the models already on the market.

Contact Information

This manual was prepared by CZM USA CORP. While deemed to be accurate, is based upon provided technical information.

This manual provides safety and basic information for operation and maintenance of the machine.

It is the responsibility of the owner, user, properly certified operator, and lessor to be knowledgeable of and comply with all industry standards, government regulations, workplace rules, and other directives that may govern and/or apply to this equipment as well as its environment/conditions of use.

Contact CZM USA CORP for additional information or assistance.

CZM FOUNDATION EQUIPMENT

HEADQUARTERS

962 Interstate Centre Boulevard
Ellabell, Georgia 31308 United States
Phone: (912) 200-7654

AFTER SALES - CALIFORNIA

1720 North Ventura Avenue
Ventura, California 93001 United States
Phone: (805) 701-9885

AFTER SALES - GEORGIA

145 East Industrial Boulevard
Pembroke, Georgia 31321 United States
Phone: (912) 200-7656

AFTER SALES - TEXAS

2501 Blue Mound Rd. W
Haslet, Texas 76052 United States
Phone: (817) 232-8053

WWW.CZM-US.COM

Special acknowledgment to:

M0080149-08 ©2022 Caterpillar All Rights Reserved
CAT, CATERPILLAR, their respective logos, "Caterpillar Yellow", and the POWER EDGE trade dress as well as corporate and product identity used herein, are trademarks of Caterpillar and may not be used without permission.

©2023 by CZM USA CORP. All rights reserved. No part of this publication may be reproduced without the written permission of the manufacturer. The manufacturer has undertaken a policy of continual improvement and reserves the right to modify this document without notice providing there is no safety risk involved.

Chapter 1

Introduction

This Operator Manual

This manual provides the operational and maintenance details for the CZM LR95 drilling rig.

This manual contains information, advice, and important warnings regarding the use of CZM equipment, which will help take full advantage of the capabilities of the drilling rig. This manual includes safety guidelines, directions for maintaining the drilling rig, and strategies for protecting the environment.

IMPORTANT: Carefully read and understand this manual before operating or servicing this machine. All personnel involved with this machine should read and understand the information in this manual.

NOTE: *CZM reserves the right to modify its products whenever it is deemed necessary.*

CZM guarantees the basic operating features for the particular model. Supplements to this manual will be made whenever required changes are made to the equipment.

Technical information updates or improvement in the design of CZM equipment are guaranteed to the customer.

Consider all the safety instructions containing the words DANGER, WARNING, or CAUTION. The partial or total disregard of these instructions may result in death or serious injury.

Consider this symbol  as an indication of environmental information within this manual to be followed, so that using the equipment causes no avoidable harm to the environment.

General Description of the Drilling Rig

The LR95 drilling rig from CZM provides high performance while having fast and easy setup from transport to operation. The drilling rig is mounted on a Caterpillar (CAT®) base to provide a reliable drilling rig, keeping the operation and maintenance tasks easy and efficient to perform.

The LR95 drilling rig is very compact. The hydraulic functions in the cab allow the kelly bar to follow the raising and lowering of the mast. With positioning hydraulic cylinders for the rotary head and A-frame, the kelly bar travels with the machine for fast and economical transport and setup.

The LR95 has the versatility to be easily converted from a standard mast to a long mast by replacing the top mast assembly, crowd cylinder, and kelly bar.

Hydraulic, extendable crawlers on the base, auxiliary counterweight, and a mast manufactured in Weldom® steel (lightweight and high-yield strength) give the LR95 excellent stability.

WELDOX is a trademark owned by the SSAB group of companies.

INTRODUCTION

Description of the Drilling Rig Components

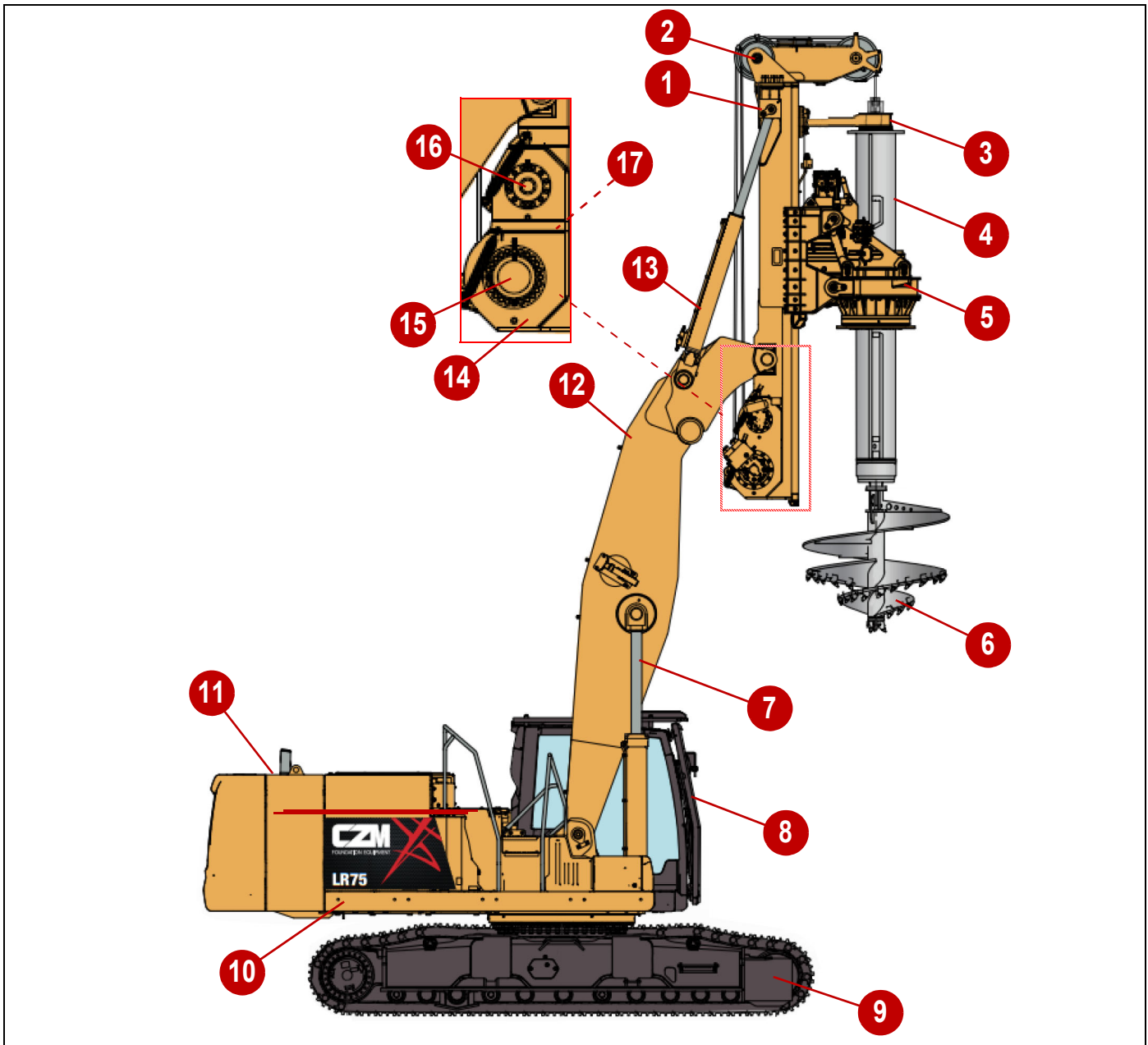

Figure 1-1

0000946/0000947

- | | |
|---------------------------|-------------------------------|
| 1) Upper Mast | 10) Base (Caterpillar) |
| 2) Head Mast | 11) Auxiliary Counterweight |
| 3) A-Frame | 12) Boom Arm |
| 4) Kelly Bar | 13) Tilting Cylinder (2 used) |
| 5) Rotary Head | 14) Mast |
| 6) Tool | 15) Main Winch |
| 7) Boom Cylinder (2 used) | 16) Auxiliary Winch |
| 8) Cab | 17) Crowd Cylinder |
| 9) Undercarriage | |

1. Upper Mast – An optional item that is only used on the long mast model, and is not used with the standard models. The upper mast is bolted to the mast.
2. Head Mast – Supports the winch cable pulleys.
3. A-Frame – Guides the kelly bar along the mast rail.
4. Kelly Bar – A set of coupled, telescopic pipes for transmitting all the thrust of the crowd cylinder and the torque of the rotary head to the tool.
5. Rotary Head – Turns the tool by means of a drive unit with a power-shift gear. Continuous speed adjustment provides high torque during drilling and high speed during unloading. The rotary head is supported by the mast, where it can slide vertically.
6. Tool – Varies in type and size depending on the foundation requirements.
7. Boom Cylinders – Control the movement of the boom.
8. Cab – Area where the operator is seated for operation of the machine base and drilling rig. The operator seat is designed and manufactured according to ergonomic principles.
9. Undercarriage – The undercarriage is hydraulically extendable. It can be retracted for transport and extended for operation, enhancing the stability of the drilling rig.
10. Base (Caterpillar) – The CAT® base is a modified commercial excavator base, a hydraulically driven revolving platform to which the drilling rig is attached.
11. Auxiliary Counterweight – The auxiliary counterweight provides additional stability to the drilling rig.
12. Boom Arm – Connects the mast to the chassis and moves the mast along with the tilting cylinders.
13. Tilting Cylinders – Used for moving the mast to the transport or working positions and for controlling the alignment of the mast.
14. Mast – The mast is the load-bearing structure made of high strength material. It is connected to the CAT® (Caterpillar) base by an articulated joint that enables it to tilt on both sides as well as backward and forward.
15. Main Winch – The main winch lifts the kelly bar. The main winch is equipped with the bottom hole system, which increases the life of the steel rope. This unique feature prevents the cable from losing tension when the auger reaches the bottom of the hole by braking the winch motor when there is no longer weight being lifted by the winch. This prevents the winch cable from touching the kelly bar inner wall while drilling and also helps maintain a perfect winding on the winch drum.
16. Auxiliary Winch – Lifts the tool or casing for installation.
17. Crowd Cylinder – Exerts an axial thrust on the tool.

INTRODUCTION

Undercarriage

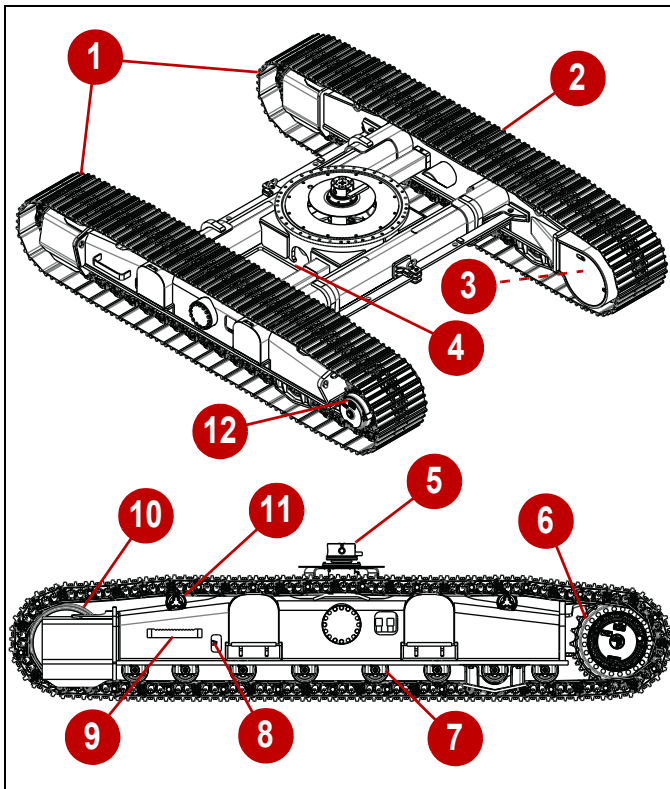

Figure 1-2

0000232/0000261

- | | |
|-------------------------------------|---|
| 1) Track Chain (2 used) | 7) Track Lower Roller (multiple) |
| 2) Track Shoe (multiple) | 8) Track Tensioner Greasing Point (each side) |
| 3) Track Motor and Valve (2 used) | 9) Track Steps (each side) |
| 4) Undercarriage Cylinders (2 used) | 10) Track Wheel (2 used) |
| 5) Undercarriage Swivel | 11) Track Upper Roller (multiple) |
| 6) Drive Wheel (2 used) | 12) Track Planetary Drive (2 used) |

The undercarriage of a drilling rig encompasses the tracks, track frame, and the hydraulic motor/gearing.

The undercarriage is part of the base machine. It is connected to the upper structure at the swing bearing and the undercarriage swivel (5).

The undercarriage includes the tracks consisting of track chains (1), track links, pins, rollers, and track shoes (2). The track system also includes the track motor and valves (3), drive wheels (6), track lower rollers (7), track wheels (10), track upper rollers (11), and track planetary drives (12).

Cylinders inside the frame extend the side track frames or retract to pull them inward.

The track motors and planetary drives are responsible for moving the drilling rig at the job site. For long distances, the drilling rig should be transported by truck to reduce the wear on the track system.

Since the undercarriage supports the drilling rig, it is important to maintain and take proper care of it. Failure to perform routine maintenance can lead to breakdowns and other mechanical problems that can take the drilling rig out of service.

Cleaning and removing any debris from the undercarriage after each shift helps keep all the moving parts functioning properly. This is especially important in cooler climates because frozen debris can wear away at bolts, fasteners, and other connections in the undercarriage. There are many moving parts in this part of a drilling rig, and keeping everything moving by clearing all debris is important.

Undercarriages should also be a standard part of daily inspections. Track shoes, chains, bolts, and tensions as well as rock guards, track motors, and drive wheels should be checked every day. Following best practices for driving and operation will also help to maintain the undercarriage of a drilling rig. Making wide turns, minimizing time on slopes, using the proper grouser, avoiding harsh terrain, and minimizing excessive spinning all help with the upkeep of the undercarriage.

Counterweights

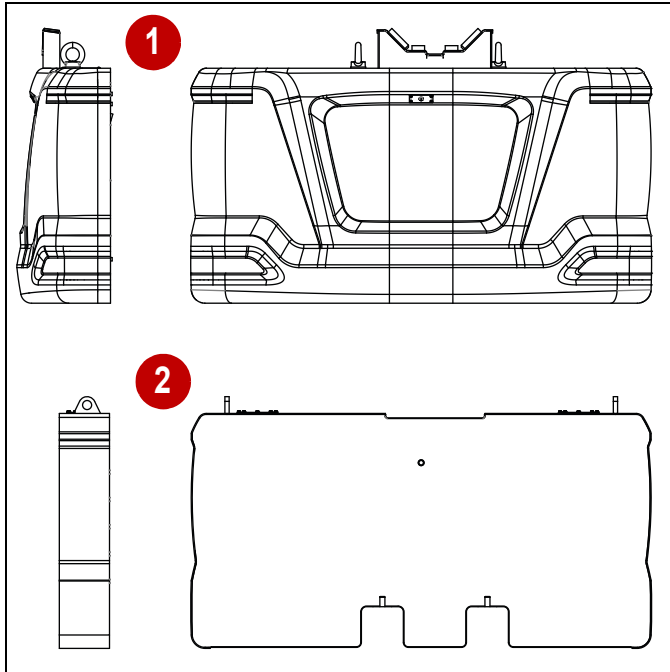

Figure 1-3

0000262

- | | |
|--|---|
| 1) Main CAT®
Counterweight
Weight: 14,770 lb.
(6700 kg) | 2) Auxiliary
Counterweight
Weight |
|--|---|

This drilling rig has two counterweights. They are attached to the back of the base machine. They balance the weight of the drilling rig.

The main CAT® counterweight (1) and the auxiliary counterweight (2) can both be optionally removed to reduce the transport weight.

Follow the conditions on which the machine can safely move without any counterweight. Pay attention to the safe procedure to install and remove the counterweights.

Base Machine

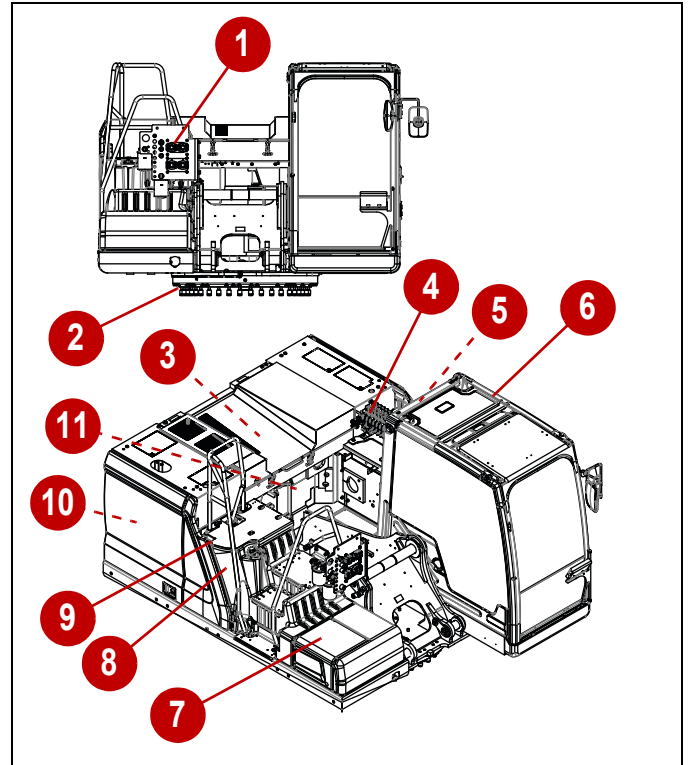

Figure 1-4

0000263

- | | |
|--|-----------------------------------|
| 1) Base Manifold | 7) DEF Tank
Compartment |
| 2) Swing Bearing | 8) Diesel Fuel Tank |
| 3) Diesel Engine | 9) Hydraulic Tank |
| 4) Auxiliary Proportional
Control Valve | 10) Hydraulic Pump
Compartment |
| 5) Battery Compartment | 11) Main Cat Control Valve |
| 6) Cab | |

The LR95 base machine is a modified commercial excavator base with a hydraulically driven revolving platform with the drilling rig attached.

It is mounted on the top of the undercarriage through the swing bearing.

The counterweights are mounted on the back and the boom to the front. The base machine is where the diesel engine, hydraulic pumps, control valves, diesel and hydraulic tanks, and the cab are located.

Cab

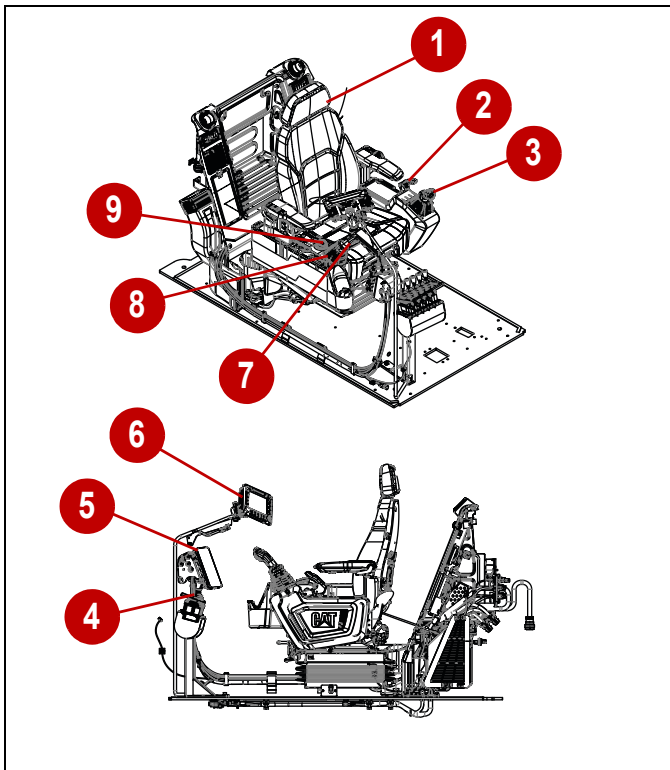

Figure 1-5

0000264

- | | |
|--------------------------------|----------------------|
| 1) Operator Seat | 6) CZM Display |
| 2) Hydraulic Lockout Lever | 7) Right Joystick |
| 3) Left Joystick | 8) CAT® Display Knob |
| 4) Auxiliary Joystick (5 used) | 9) On/Off Switch |
| 5) CAT® Display | |

The cab is where the operator is seated to operate the base machine and control the drilling rig. The operator seat is designed and manufactured according to ergonomic principles.

The operator should always wear the seat belt and close the door while the drilling rig is turned on.

The CZM display provides the operator with information on the drilling parameters and functions. The CAT® display provides the operator with information on the base machine.

When the hydraulic lockout lever is pushed down, all the hydraulic functions are deactivated.

The right and left joysticks will control the main functions for drilling. The auxiliary joysticks are a 5-lever valve that controls the drilling rig setup.

Mast

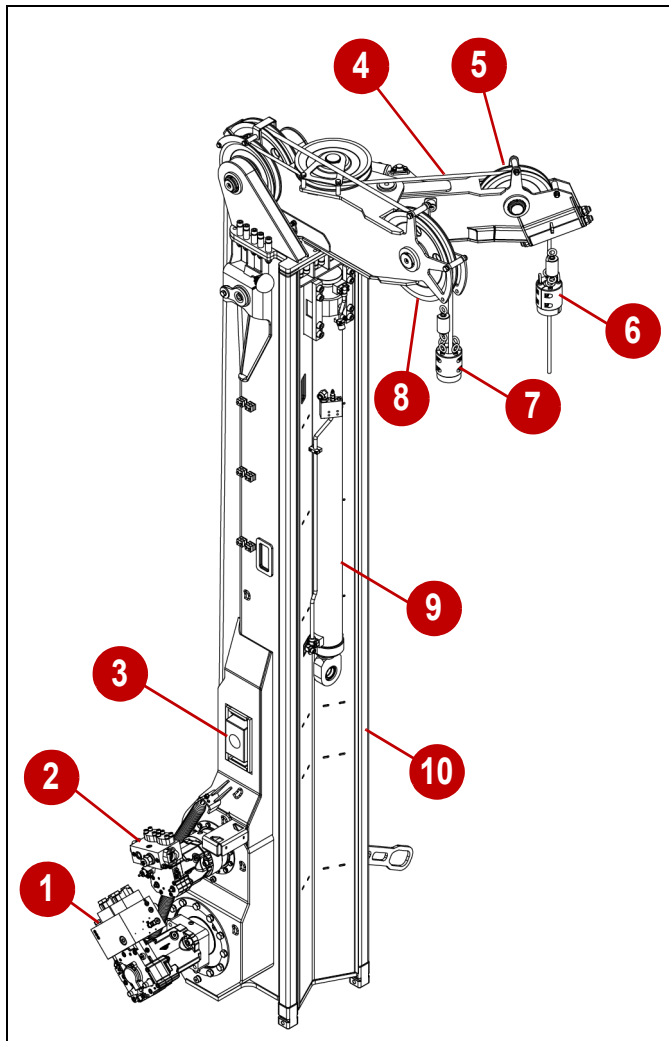

Figure 1-6

0000869

- | | |
|---------------------------|---------------------------------|
| 1) Main Winch | 6) Auxiliary Winch Limit Switch |
| 2) Auxiliary Winch | 7) Main Winch Limit Switch |
| 3) Articulated Joint | 8) Main Winch Pulley |
| 4) Head Mast | 9) Crowd Cylinder |
| 5) Auxiliary Winch Pulley | 10) Main Mast |

Main Mast

The main mast (10) provides a mounting point for the main winch (1), auxiliary winch (2), head mast (4), and crowd cylinder (9).

Upper Mast

The upper mast assembly (not shown) is not present on the standard (short) mast configuration and is added to extend the mast. The LR95 is converted between standard and long mast versions by removing/installing the top mast assembly, crowd cylinder (9), and kelly bar.

Articulated Joint

The main mast is connected to the CAT® base machine by an articulated joint (3) that enables the mast to tilt on both sides as well as backward and forward. The articulated joint needs to resist the torque of the rotary and crowd force, main winch pull force, and auxiliary winch pull force.

Mast Inclination

Maximum mast inclinations:

- Backward - 15°
- Forward - 10°
- Sideways - 12° left and 12° right

INTRODUCTION

Head Mast

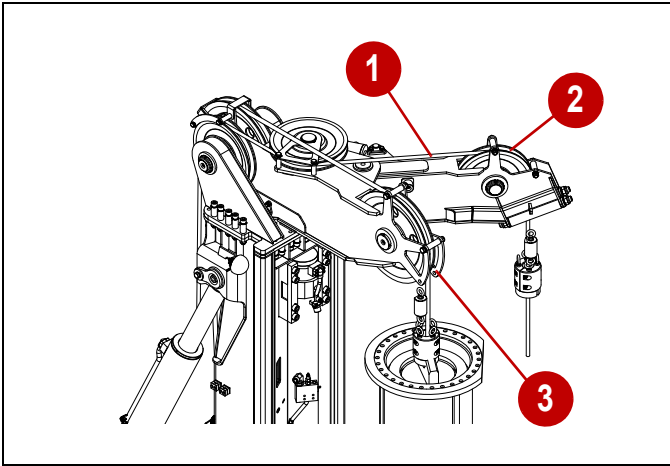

Figure 1-7

0000453

- 1) Head Mast
- 2) Main Winch Pulley
- 3) Auxiliary Winch Pulley

The head mast (1) is the top of the mast where the main winch pulley (3) and auxiliary winch pulley (2) are located.

A-Frame

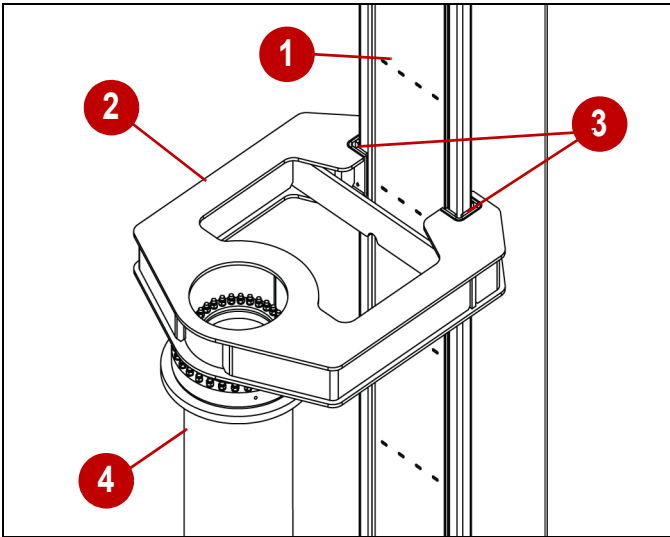

Figure 1-8

0001935

- 1) Mast
- 2) A-frame
- 3) Wear Pads
- 4) Kelly Bar

The A-frame (2) guides the kelly bar (4) along the mast rail (1). Wear pads (3) protect and reduce the friction of the sliding surfaces.

Crowd Cylinder

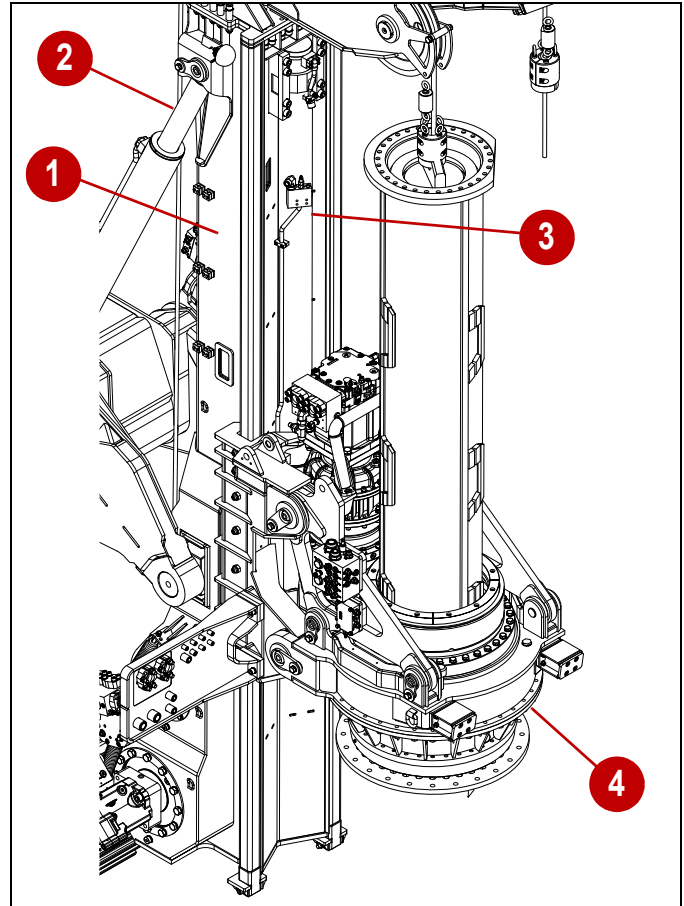

Figure 1-9

00000454

- 1) Mast
- 2) Mast Tilt Cylinder (2 used)
- 3) Crowd Cylinder
- 4) Rotary

The crowd cylinder connects the rotary to the mast. It is responsible for moving the rotary up and down the mast and applying crowd force to the drilling tool. The crowd force is measured and displayed to the operator on the CZM monitor inside the cab.

The machine has a regenerative hydraulic system for the crowd operation, which increases the speed to lower the cylinder.

The operator should not overcrowd or lift the machine more than 2.5 degrees of horizontal as it may damage the kelly bar. The CZM control system can limit the maximum crowd force, based on the inclination of the machine and based on the maximum torque, to achieve best drilling performance.

The operator may also apply auto crowd, which will automatically apply crowd force until a certain depth is achieved.

NOTE: See "Crowd System" on page 4-1.

Main Winch

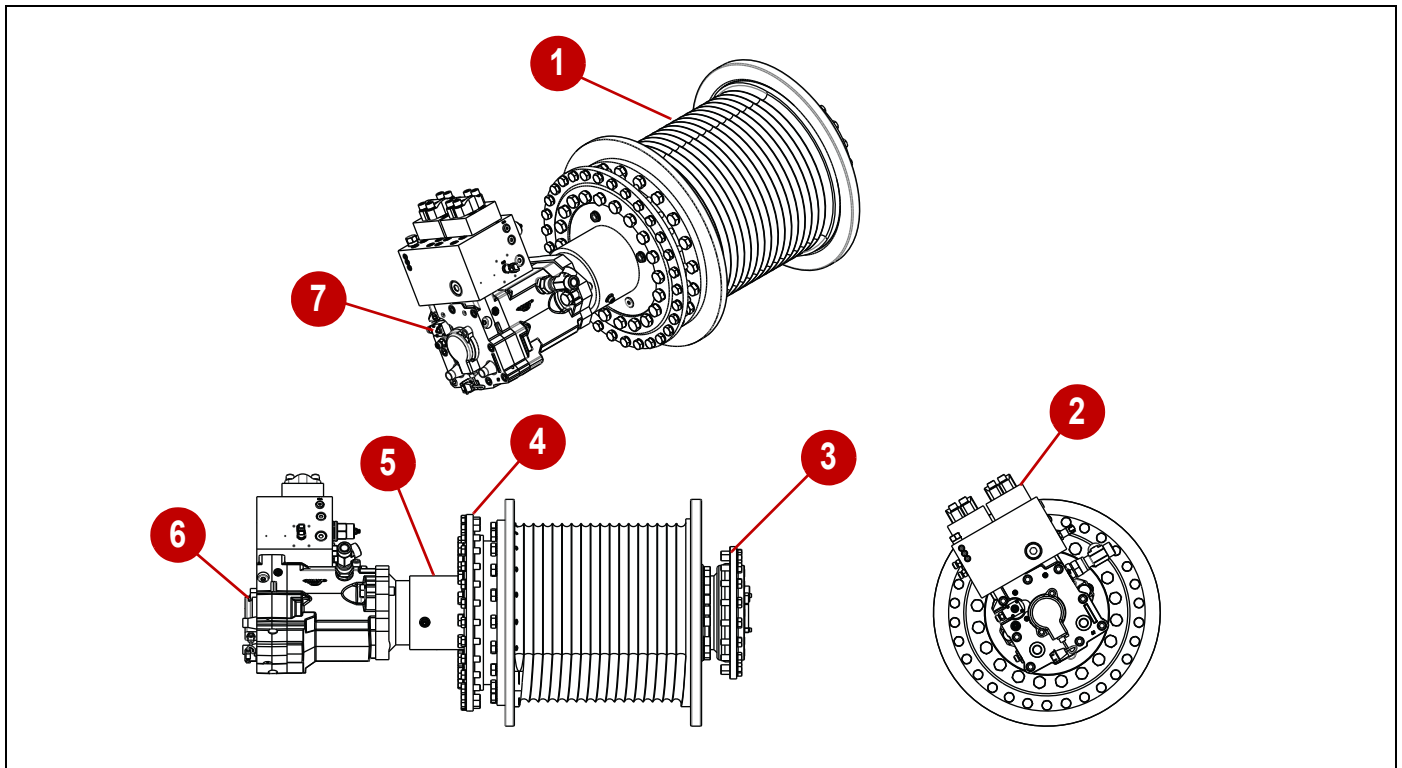

Figure 1-10

0000235

- | | | | |
|-----------------------|--------------------------|----------------------|---------------------------|
| 1) Main Winch Drum | 3) Winch Bearing | 5) Winch Brake | 7) Hydraulic Piston Motor |
| 2) Hydraulic Manifold | 4) Winch Planetary Drive | 6) Main Winch Sensor | |

The main winch is connected to the kelly bar inner element through the kelly bar swivel and is responsible for lowering and lifting the kelly bar and auger.

The main winch consists of an hydraulic piston motor (7) that is connected to a winch planetary drive (4) inside the main winch drum (1). The hydraulic manifold (2) is mounted on top of the hydraulic piston motor. The hydraulic piston motor has two speeds for increased productivity, and the machine control can change the speeds automatically based on the required load. There is also an integral main winch sensor (6) to measure the depth and line speed.

The planetary drive has a mechanical winch brake (5). The main winch drum is supported between sets of winch bearings (3) to provide smooth rotation.

The hydraulic manifold has a dynamic holding valve, which is a down the hole function that automatically stops the winch from turning when the kelly bar hits the bottom of the hole. There is also a free wheeling function that drops the kelly bar at the same speed as the crowd cylinder during crowd operation.

The main winch drum has special grooves for extended cable life.

NOTE: See “Main Winch” on page 4-1 for specifications.

Auxiliary Winch

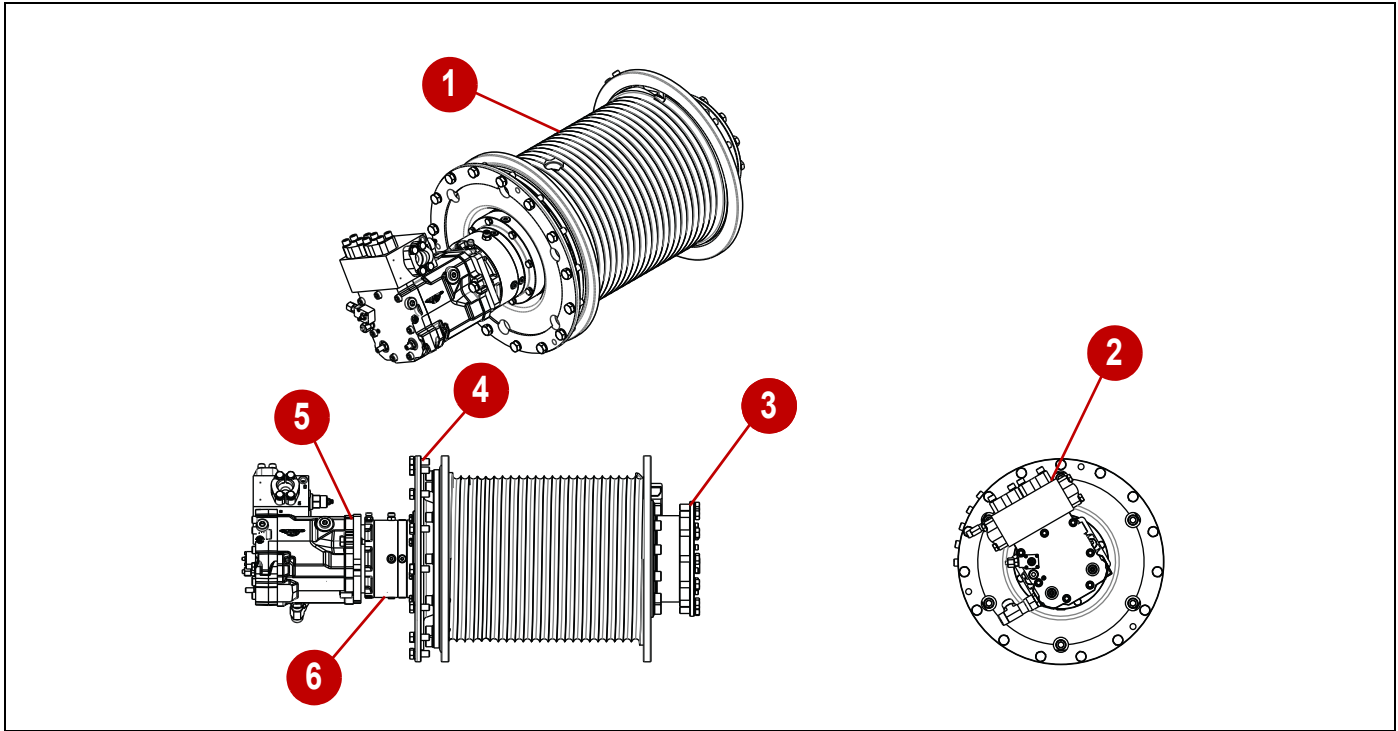

Figure 1-11

0000236

- 1) Auxiliary Winch Drum
- 2) Winch Hydraulic Manifold
- 3) Winch Bearing
- 4) Winch Planetary Drive
- 5) Winch Hydraulic Piston Motor
- 6) Winch Brake

The auxiliary winch is used to lift loads close to the machine. It consists of a winch hydraulic piston motor (5) that is connected to the winch planetary drive (4) inside the auxiliary winch drum (1). The auxiliary winch drum is supported between sets of winch bearings (3) to provide smooth rotation.

The winch hydraulic manifold (2) is mounted on top of the hydraulic motor and controls the hydraulic oil flow.

The planetary drive has a mechanical winch brake (6).

The hydraulic manifold has a dynamic holding valve.

⚠ WARNING

The auxiliary winch is not to be used as a crane. Excessive stress to the winch cable and the drilling rig could result in death or serious injury.

NOTE: See “Auxiliary Winch” on page 4-1 for specifications.

Rotary

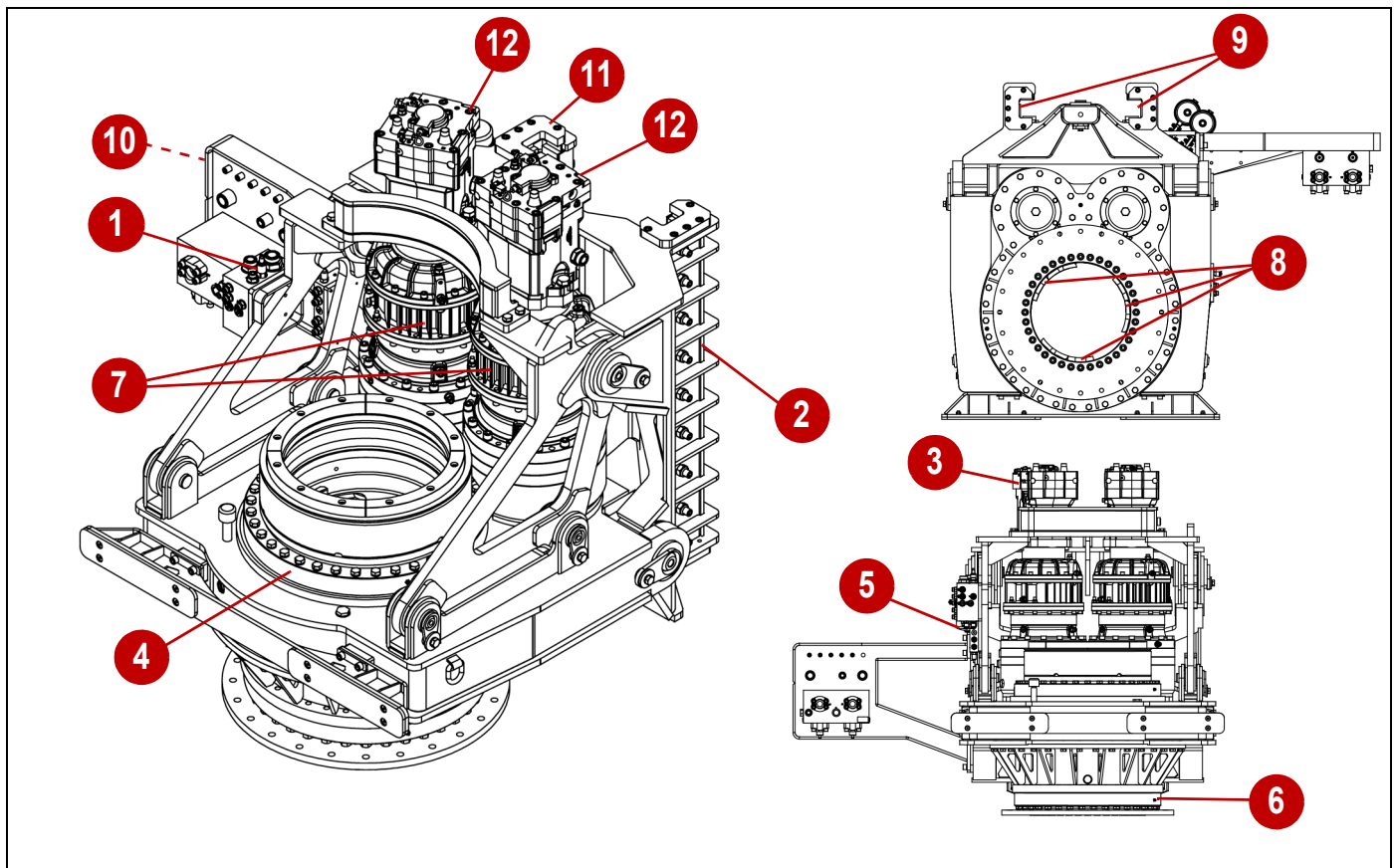

Figure 1-12

0001932 0001930 0001931

- | | | |
|--------------------------|----------------------------|-----------------------------------|
| 1) Rotary Drain Manifold | 5) Sequence Valve Manifold | 9) Rotary Wear Pad (multiple) |
| 2) Rotary Sled | 6) Rotary Lower Bearing | 10) Rotary Manifold |
| 3) Rotary Speed Sensor | 7) Rotary Planetary Drive | 11) Rotary Motor Manifold |
| 4) Rotary Upper Bearing | 8) Rotary Key (multiple) | 12) Rotary Hydraulic Piston Motor |

The rotary is connected to the mast through the crowd cylinder. It transfers torque and crowd force to the kelly bar that runs through it. The rotary consists of two rotary hydraulic piston motors (12) that is connected to a two-speed rotary planetary drive (7) and then to a pinion and main crown gear inside the rotary case. The rotary planetary drive has a clutch that changes the gear ratio, providing two speeds. The first speed is for drilling and the second speed is for spin off.

The rotary hydraulic piston motor has a variable displacement so that the operator can change the drilling speeds. The rotary hydraulic piston motor has a rotary speed sensor (3) to measure the output drilling rpm that is displayed to the operator in the cab. The torque is measured by a pressure transducer in the rotary line.

The rotary motor manifold (11) has an anti-shock and anti-cavitation system to increase the life of the rotary hydraulic piston motor. This system allows the operator to abruptly change the reverse of the auger during drilling and spin off and to shake off the tool for faster auger cleaning.

The machine will auto shift the gears depending on the required load. The kelly bar shock absorber protects the rotary from kelly bar impact. The rotary keys (8) lock to the kelly bar. Grease the rotary keys per the maintenance schedule and replace them when worn to prevent damage to the kelly bar.

The rotary wear pads (9) are located inside the rotary sled (2) and run on the mast rails. Grease the rotary wear pads per the maintenance schedule and replace them when worn to prevent damage to the mast rails.

NOTE: See “Rotary Head – RT 406 - 10 (Standard)” on page 4-1 for specifications.

Kelly Bar

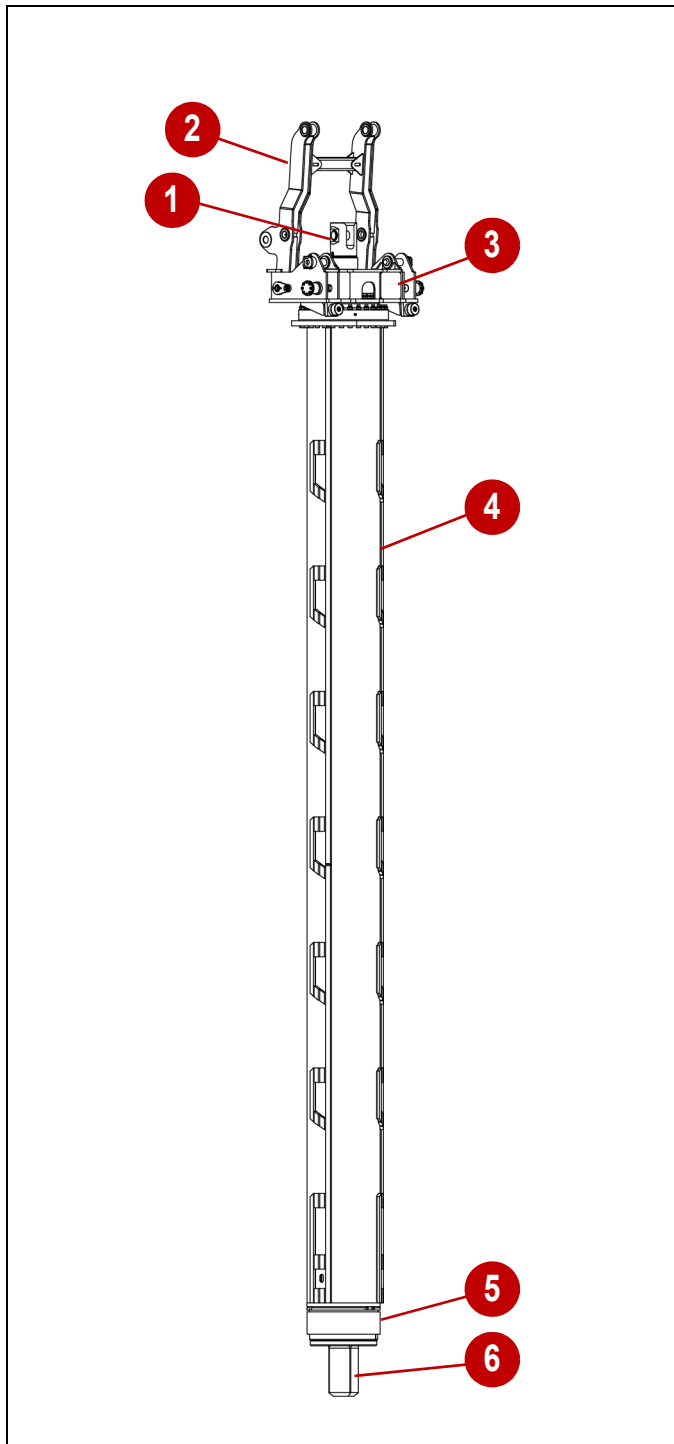

Figure 1-13

0000870

- | | |
|---------------------|-------------------|
| 1) Kelly Bar Swivel | 4) Kelly Bar |
| 2) A-Frame | 5) Bell Housing |
| 3) A-Frame Bearing | 6) Kelly Bar Stub |

The kelly bar (4) is the main drilling tool connected to the auger. It consists of telescopic pipes with vertical rails that lock for transmitting torque and crowd force in between the kelly elements.

There are two kelly bar types: friction kelly bars and interlocking kelly bars.

- Friction kelly bar: The crowd force is only transmitted to the inside elements by the friction in between the vertical rails.
- Interlocking kelly bars: There are also horizontal keys that lock the elements to each other, transferring the maximum torque for an effective crowd force to the auger.

The number of elements and length of the kelly bar determine the maximum drilling depth. Generally, a kelly bar will consist of three to five elements.

The length of the kelly bar needs to match the length of the mast. The clearance under the tool will be determined by the length of mast and length of kelly bar.

The kelly bar is lowered and lifted from the hole by the main winch line. The winch line is connected to the kelly bar swivel (1). The swivel prevents the kelly bar from twisting the main winch cable.

The rotary transmits the torque and crowd for the drilling with the kelly bar running through the inside of it.

The kelly bar stub (6) is at the bottom of the kelly bar that connects to the tool. It is a square extension with one or two holes for different tool configurations.

The A-frame (2) is connected to the top of the kelly bar outer element. Mast rails guide the A-frame up and down the mast. Make sure the A-frame wear pads are greased and replace them when worn to avoid damaging the rails.

For longer kelly bar life, don't overcrowd by lifting the base machine off the ground.

Frequently inspect the kelly bar for cracks and repair immediately. Inspect the wear keys and repair as needed.

Hydraulic Components

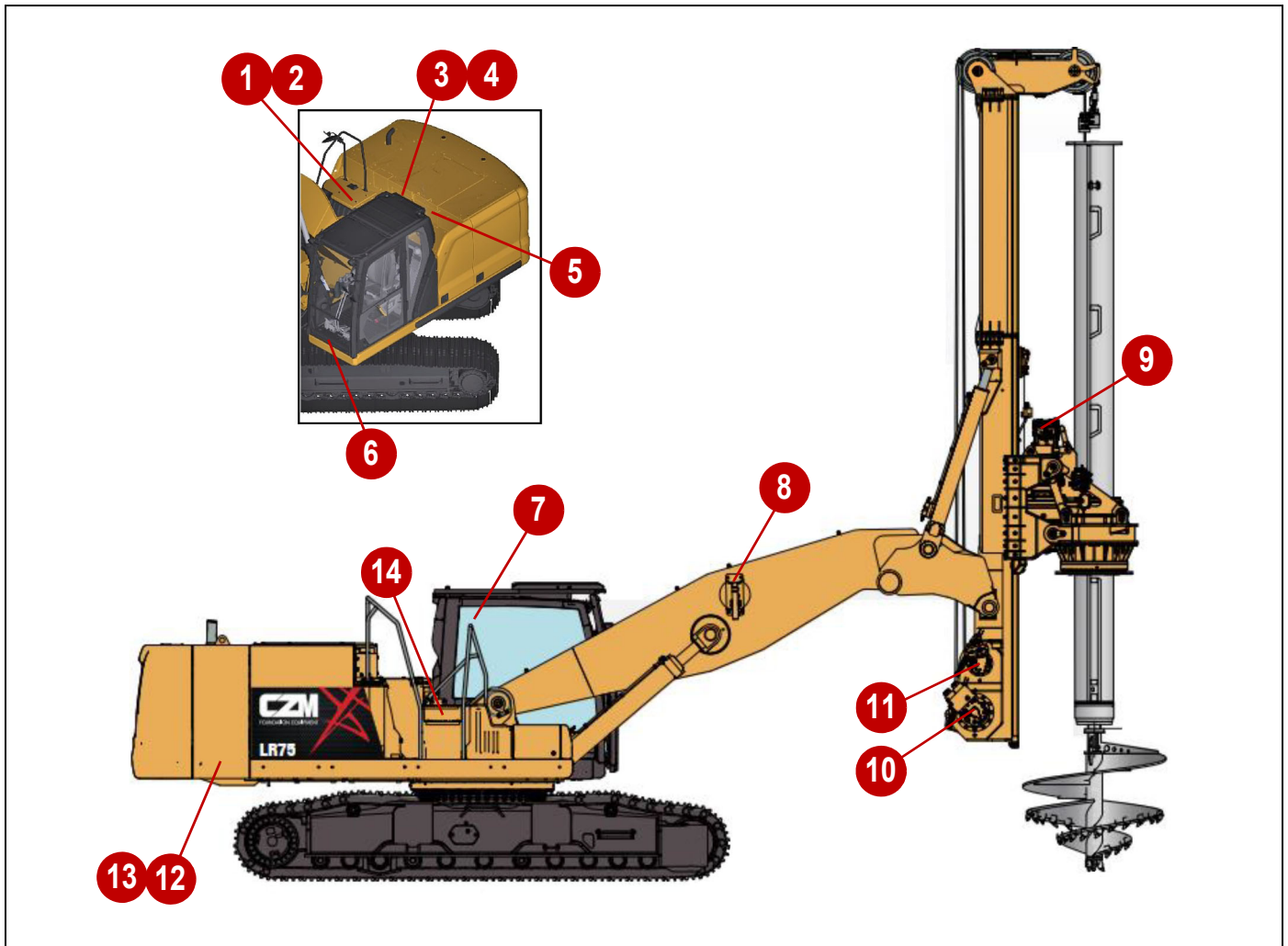

Figure 1-14

0000921

- | | |
|-------------------------------|-----------------------------|
| 1) Return Filter 25 psi | 8) Solenoid Block* |
| 2) Return Filter 5 psi | 9) Rotary Block |
| 3) Main Winch Return Valve* | 10) Main Winch Block |
| 4) Drain Block | 11) Auxiliary Winch Block |
| 5) Auxiliary Control Valve* | 12) Auxiliary Piston Pump |
| 6) Pressure Gauge (3 used)** | 13) Auxiliary Gear Pump |
| 7) Regenerative System Block* | 14) Main CAT® Control Valve |

* Electro-hydraulic component

** See "Main and Auxiliary Pump Gauges" on page 6-14 for more details.

INTRODUCTION

1. Return Filter (25 psi) – One of the two drain return filters mounted to the base manifold. The upper filter is connected to the rotary gearbox system (powershift).
2. Return Filter (5 psi) – One of the two drain return filters mounted to the base manifold. The lower filter is connected to the hydraulic motors (rotary, main, and auxiliary winches).
3. Main Winch Return Valve: Electro-hydraulic component.
4. Drain Block: Electro-hydraulic component.
5. Auxiliary Control Valve – Located behind the cab, this block controls the base machine swing, undercarriage, and controls the hydraulic cylinders for mast tilting, boom, and crowd force.
6. Pressure Gauges – Operator's interface for monitoring the pressure of the main pumps and of the auxiliary piston pump.
7. Regenerative System Block – Increases the speed of cylinder extension of the crowd cylinder, which increases the productivity of the drilling rig.
8. Solenoid Block* – Controls the down hole system, main winch brake, free-fall system, power shift, main winch speed, and rotary speed.
9. Rotary Block – Located on the rotary motor, this block decreases the possibility of cavitation by feeding the motor with an extra oil line. This block also increases the service life of the motor.
10. Main Winch Block – Located on the mast and connected to the winch motor, this block is responsible for the counterbalance function and for releasing the winch brake.
11. Auxiliary Winch Block – Located on the mast and connected to the winch motor, this block is responsible for the counterbalance function and for releasing the winch brake.
12. Auxiliary Piston Pump – Provides high-pressure oil to the auxiliary control valve, leaving the main pumps exclusive for the rotary and winches while drilling.
13. Auxiliary Gear Pump – Provides high-pressure oil to the anti-cavitation line for rotary motors and the cooling line for the rotary and main winch motor.
14. Main CAT® Control Valve – The main CAT® control valve is supplied hydraulic oil flow by the main CAT® pumps and directs it to the rotary, main winch, left crawler, and right crawler.

Electrical Components

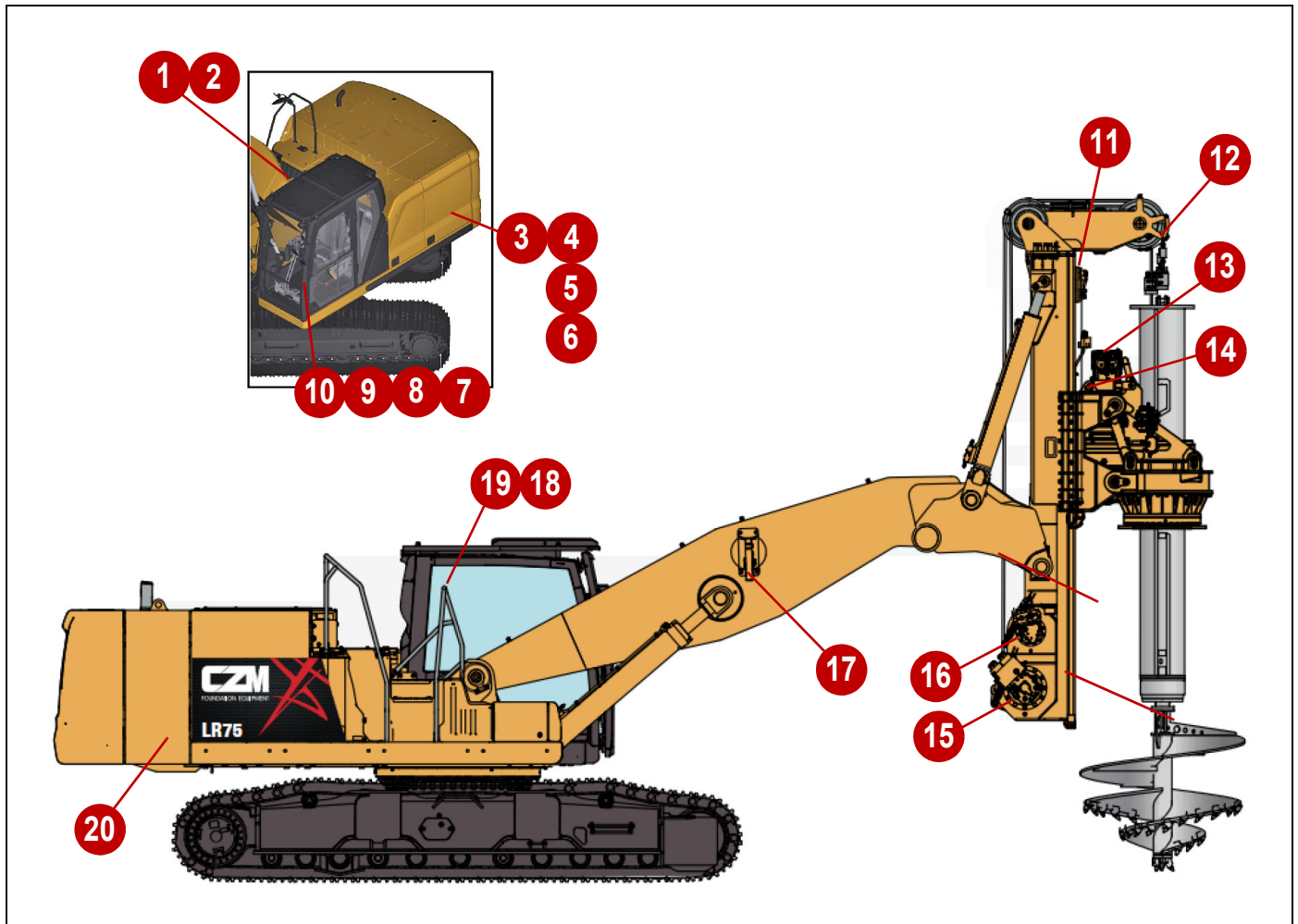

Figure 1-15

0000922

- | | |
|--------------------------------|---|
| 1) Return to Center Sensor | 11) Main Winch Stroke Limit Switch |
| 2) Return Filter Sensor | 12) Auxiliary Winch Stroke Limit Switch |
| 3) Base Controller | 13) RPM Sensor |
| 4) Base Output Expander | 14) Mast Slope Sensor |
| 5) Power Supply Box | 15) Main Winch Depth Sensor |
| 6) Cooling Controller | 16) Pressure Sensor |
| 7) CZM Monitor | 17) Mast Lights |
| 8) Auxiliary Joystick (5 used) | 18) Mast Controller |
| 9) Cab Controller | 19) Mast Output Expansion Module |
| 10) Signal Conditioning Module | 20) Pump P1 Pressure Sensor |

INTRODUCTION

1. Return to Center Sensor – An encoder mounted on the top of the swivel. It measures the angle of the upper body compared to the undercarriage, and it is used to automatically return the drilling rig back to the center of the hole.
2. Return Filter Sensor – Provides a signal to the operator that the return filter is clogged and is bypassing hydraulic oil to the tank. In that case, the filter cartridge should be replaced.
3. Base Controller – A CAN bus module located in the battery compartment. It controls the solenoids for the auxiliary proportional control valve and pressure sensors.
4. Base Output Expansion Module – A CAN bus module that expands the number of outputs for the base controller.
5. Power Supply Box – Distributes incoming power through relays and switches to the entire CZM electronic system.
6. Cooling Controller – A CAN bus module located in the heat exchanger compartment. It controls the output for the electric fans for the hydraulic oil heat exchanger, engine, and engine coolant.
7. CZM Monitor – Monitors and controls the drilling components of the machine. It is connected to the base controller module by a CAN bus line. It provides information to the operator for machine operations such as: drilling torque, rotary speed, and main winch provides the operator the maintenance schedule.
8. Auxiliary Joysticks – Joysticks are located inside the cab, in front of the operator seat. These joysticks control the auxiliary winch, boom, left tilting cylinder, and right tilting cylinder.
9. Cab Controller – A CAN bus module located inside the cab, behind the seat. It controls the inputs and outputs from the CAT[®] joysticks and the auxiliary joysticks. It also connects to the CZM monitor.
10. Signal Conditioning Module – Located inside the cab, behind the seat. It converts the signal of the Caterpillar joysticks from 5V to 7V, so the signals can be read by the CZM electronic system.
11. Main Winch Stroke Limit Switch – An anti 2-block that stops the main winch from going up and hitting the pulley. The switch is normally open, so if it is damaged, the main winch will not go up. This limit switch can be bypassed by the operator in the cab, but this should only be done using extreme caution. A damaged limit switch must be repaired as soon as possible.
12. Auxiliary Winch Stroke Limit Switch – An anti 2-block that stops the auxiliary winch from going up and hitting the pulley. The switch is normally open, so if it is damaged, the auxiliary winch will not go up. The limit switch can be bypassed by the operator in the cab, but this should only be done using extreme caution. A damaged limit switch must be repaired as soon as possible.
13. RPM Sensor – A speed sensor mounted to the rotary hydraulic motor. It measures the rotation of the motor and is used to calculate the output rpm of the rotary. This information is displayed to the operator on the CZM monitor.
14. Mast Slope Sensor – Mounted to the mast, it measures the inclination of the mast within 10 degrees from plumb. This information is displayed to the operator in the CZM monitor and is used to set the auto mast level.
15. Main Winch Depth Sensor – A speed sensor mounted to the main winch hydraulic motor. It measures the rotation of the motor which is then used to calculate the depth along with the main winch speed.
16. Pressure Sensors – Located in the base manifold, these sensors measure the hydraulic pressure for the rotary in both directions, the main winch in the up direction, and the crowd cylinder. This data is used to display the rotary torque, the main winch pull up force, and the crowd force. It is also used to automatically shift the rotary gears and the main winch gear.
17. Mast Lights – Auxiliary lights located on the mast.
18. Mast Controller – A CAN bus module located in the triangular element manifold. It controls the inputs and outputs for the solenoid manifold, the three-spool valve, the rotary rpm sensor, the main winch depth sensor, mast lights, main winch limit switch, and auxiliary winch limit switch.
19. Mast Output Expansion Module – A CAN bus module that expands the number of outputs for the mast controller.
20. Pump P1 Pressure Sensor – Sends pressure reads to the pressure gauges for operator observation during drilling operation.

Description of Symbols

	UNDERCARRIAGE CYLINDERS		POWER SHIFT		SIDE CAMERA
	CRAWLERS		MAST HEAD ROTATE		FAULTS
	FUNCTION NOT IMPLEMENTED		MAST SHOE	N/A	FUNCTION NOT IMPLEMENTED
	LEFT TILT CYLINDER		MAST LIGHTS		MAST LOCK
	RIGHT TILT CYLINDER		FUNCTION NOT IMPLEMENTED		DRILL DEPTH PROGRESS
	RETURN TO CENTER		MAIN WINCH MOVEMENT		MAIN WINCH AUTO SHIFT
	SWING		AUXILIARY WINCH MOVEMENT		MAIN WINCH LOW
	PULLDOWN CYLINDER		LIMIT SWITCH EXCLUSION MAIN WINCH		HIGH SPEED CROWD
	SET CURRENT DEPTH TO ZERO		LIMIT SWITCH EXCLUSION, AUXILIARY WINCH		
	FUNCTION NOT IMPLEMENTED		END HOLE EXCLUSION, MAIN WINCH		
	HORN		MAST AUTO LEVEL		
	ROTARY ROTATION		AUTO DRILL		
	ROTARY SPEED		AUTO CROWD		



FOUNDATION EQUIPMENT

0000871

Page Intentionally Left Blank

Chapter 2

Safety

General Safety

This section provides information on basic safety precautions, as well as preventive measures that should be followed when operating the drilling rig.

Overall safety is the responsibility of the operator and job site personnel.

For references to British Standards, consult the latest publication for drilling and foundation equipment from The British Standard Institution – BSI Standards Publication.

Hazard Alerts in This Manual

Hazard alerts in this manual are used to alert operators, job supervisors, maintenance staff, and job site workers to hazardous operating practices and maintenance procedures. Hazard alerts used throughout this manual contain a hazard-alert symbol and a signal word. They identify the hazard's degree of consequence if the message is ignored.

ANSI/ISO signal words are used to warn of potentially hazardous situations that may lead to damage, personal injury, or even death. Hazard alerts in this manual and on the machine and drilling rig decals use signal words or illustrations that are used to indicate the potential level of hazard.

The following hazard alerts are used in this manual:

DANGER

DANGER indicates a hazardous situation which, if not avoided, will result in death or serious injury.

WARNING

WARNING indicates a hazardous situation which, if not avoided, could result in death or serious injury.

CAUTION

CAUTION indicates a hazardous situation which, if not avoided, could result in injury.

NOTICE

NOTICE is used to address practices not related to personal injury.



This symbol is used within a graphic to alert the user not to do something.

Operator Safety Information

WARNING

Unsafe operation and maintenance of this drilling rig could result in death or serious injury. It must be operated and maintained by trained and experienced personnel. Do not operate or work on it without first reading and understanding this operation and maintenance manual.

It is impossible to compile a comprehensive list of safety precautions that covers every possible situation that may be encountered. However, there are basic operating guidelines and principles that must be followed when operating or working on the drilling rig:

- Only authorized and qualified personnel specifically trained on this drilling rig are permitted to operate it.
- Read and understand this manual and any accompanying manuals before operating this drilling rig to make sure all operations can be performed safely.
- Read and understand the base machine operation manual before operating the drilling rig. If there is a difference between the cross-over and the base machine manual, follow the base machine manual information.

WARNING

A seat belt must always be worn by the operator at all times during machine operation in the event of an accident or machine overturn. Failure to wear a seat belt could result in death or serious injury.

- The operator should use a signal person when critical operating areas are obstructed from view. The operator shall respond to hand signals from the designated signal person only.
- Make sure all job site personnel understand industry-standard hand signals.
- Never perform any maintenance or servicing on the drilling rig with the engine running.

SAFETY

- Never misuse, override, eliminate, or bypass any safety device. Failure to comply with this requirement can increase the risk to personal health and safety.
- Never leave the seat with the engine running.
- Never lower the tools, accessories, or the mast if they are out of the operator's view.
- Do not allow job site personnel near or below implements that may be raised from the ground.
- Lower the mast, and rest the mechanical auger on the ground before leaving the seat. Place the hydraulic lockout control lever in the lock position and turn the key switch to OFF.
- Inform all job site personnel assisting with operations of the operations being performed to ensure safety.
- Verify job site ground conditions will support intended operations. Check for obstructions, such as overhead power lines, before starting and moving the drilling rig. See "Above Ground Hazards" on page 2-30.
- Make sure all underground utilities have been marked before drilling operations are started.

Personnel

This manual is written for all personnel who, regardless of the professional position held, come into direct contact with the machine or are working in the area surrounding the machine.

Machine Operator

A selected technician who is appropriately trained (in compliance with the legislation in force in the country of use) and is qualified to use the machine. The operator performs his duties in full compliance with the instructions in this manual.

The operator using the machine must meet the following requirements:

- Be physically and mentally fit for his job.
- Be properly trained and have recognized skills.
- Know the signs in use on the construction site.
- Has read this manual carefully before using the machine.
- Has knowledge of the performance and limits of use of the machine.
- Know all the safety devices installed in the machine.

Operator Assistant

Only one operator is necessary to use this drilling rig. However, it is recommended the presence of one or more assistants. An operator assistant is a technician suitably trained to assist with the machine's operation.

The operator assistance staff can be composed of one or more job site operators who use other machines (cranes, shovels, and so on), provide service to the machine, and collaborate with the operator.

The assistant must meet the following requirements:

- Be physically and mentally fit for the job.
- Be properly trained and have recognized skills.
- Know the signs in use on the construction site.
- Has read and understands the content of this manual.

CZM Technician

A qualified technician, made available by CZM, to carry out:

- Technical assistance.
- Ordinary and extraordinary maintenance.
- Operations not listed in this manual that require specific knowledge of the machine.

Specialized Technician

The specialized technician is responsible for and/or authorized by the manufacturer or his dealer to carry out interventions on the machine or on the equipment installed, in which precise technical competence and special skills are required.

The fields of specialization can differ according to the type of intervention (mechanical, hydraulic, electrical, and so on).

The technician, in addition to having specific skills in the field of intervention, must be able to read and interpret the relevant diagrams (electrical, electronic, hydraulic, and so on) to recognize the different characteristics and functions of the devices.

The specialized technician, who carries out interventions on the machine, must meet the following requirements:

- Be properly trained and have recognized skills in the specific field (electrical, hydraulic, and so on).
- Read this manual carefully before using the machine.
- Knows about the specific risks of the machine.

Signal Person and Hand Signals

⚠️ WARNING

Hand signals must be mutually agreed upon by the operator and the signal person before operations begin. Proper communication is essential to job site safety. Failure to follow this warning could result in death or serious injury.

Responsibilities of the signal person include:

- Using hand signals that are easily identified and understood by the operator to provide effective communication.
- Standing in a safe location while observing potential hazards within the danger zone. See “Danger Zone” on page 2-37 for additional information.

Different countries may have different hand signals, follow the local hand signal standards.

Personal Protective Equipment (PPE)

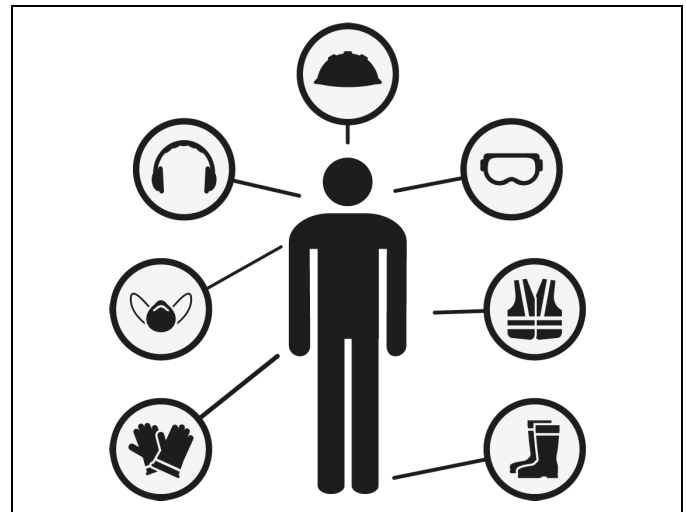

Figure 2-1

0000828

⚠️ WARNING

- Do not wear rings, wristwatches, jewelry, or loose or dangling clothing that can get caught in moving parts.
- Wear a helmet that is clean and in good condition. Each operator must personally carry out helmet adjustments for a secure and comfortable fit.
- Wear gloves that are snug, with no protruding material that could get caught in the machine mechanisms. Gloves must protect against abrasions caused by metal cables and irregular, angular, and sharp edges.
- Consult the site manager about the safety regulations in force and any accident prevention devices.
- To work in full compliance with safety regulations, it is necessary to wear protective clothing in accordance with safety regulations. Check that protective equipment is always in good condition.
- Each visitor authorized to enter the work area must wear all the personal protective equipment required by law for work on site.

Failure to follow these warnings may result in death or serious injury.

SAFETY

Safety Messages*

SMCS Code: 7000; 7405

There are several specific safety messages on this machine. The exact location of the hazards and the description of the hazards are reviewed in this section. Please become familiarized with all safety messages.

Make sure that all the safety messages are legible. Clean the safety messages or replace the safety messages if you cannot read the words. Replace the illustrations if the illustrations are not visible. When you clean the safety messages, use a cloth, water, and soap. Do not use solvent, gasoline, or other harsh chemicals to clean the safety messages.

Solvents, gasoline, or harsh chemicals could loosen the adhesive that secures the safety message. Loose adhesive will allow the safety message to fall.

Replace any safety message that is damaged or missing. If a safety message is attached to a part that is replaced, install a safety message on the replacement part. Any CAT® dealer can provide new safety messages.

Safety Decals

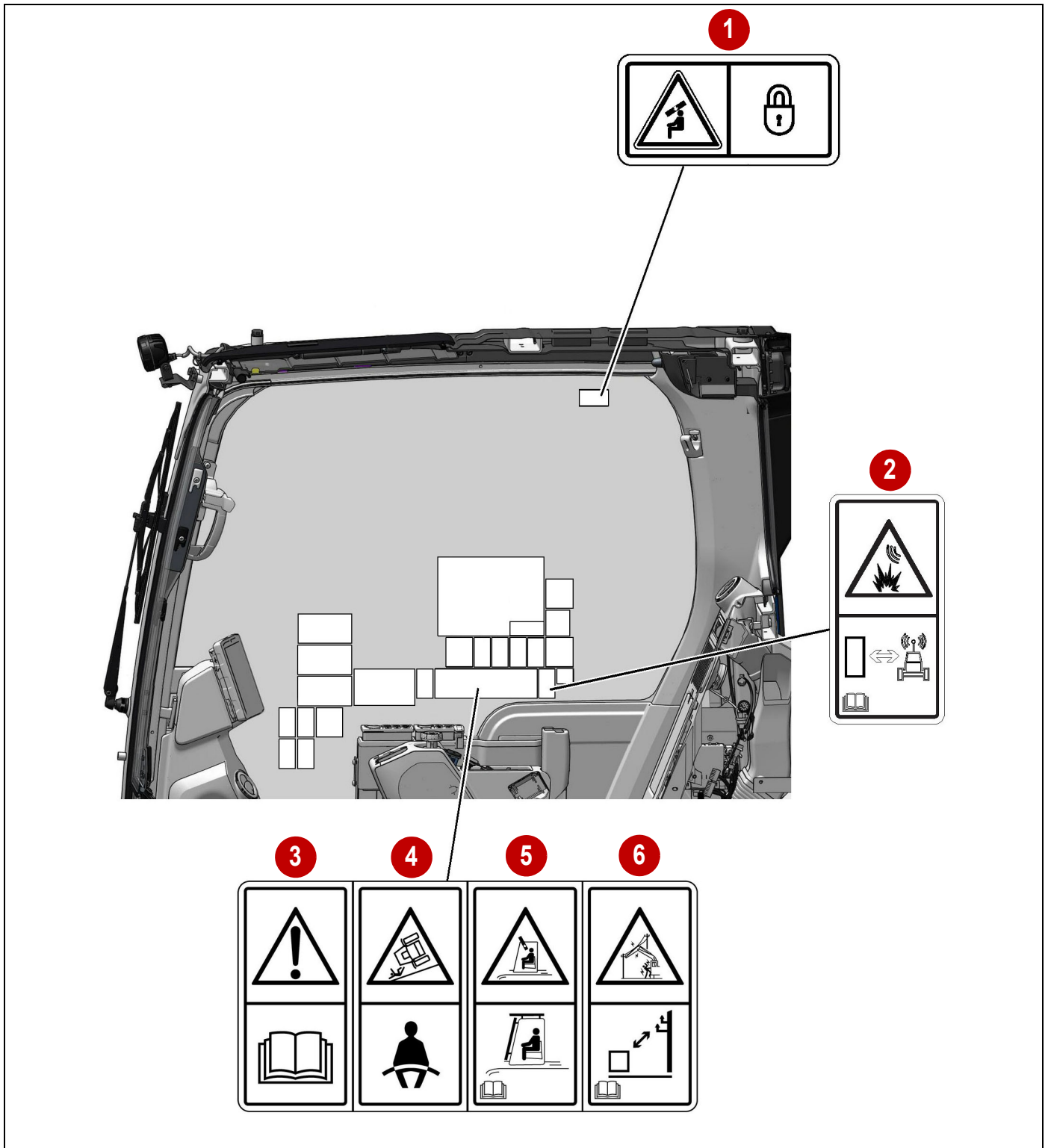

Figure 2-2

0000923

SAFETY

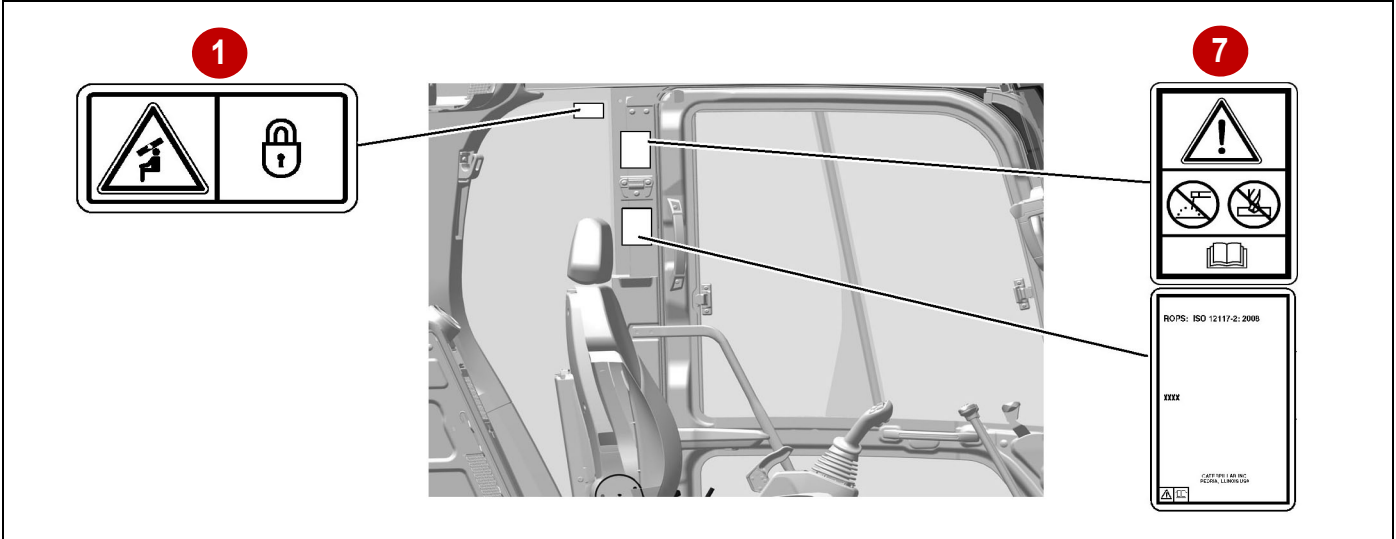

Figure 2-3

0000924

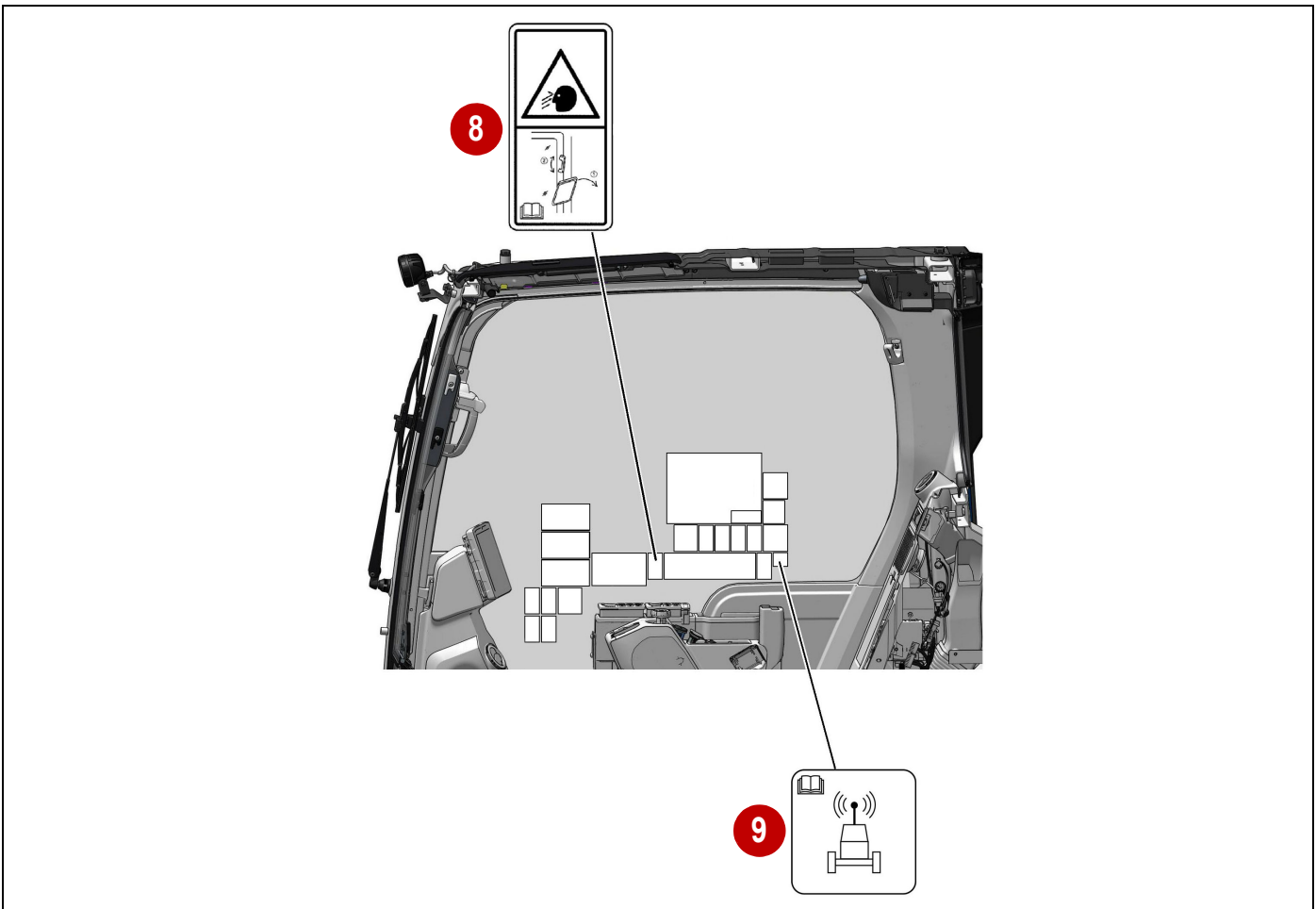

Figure 2-4

0000933

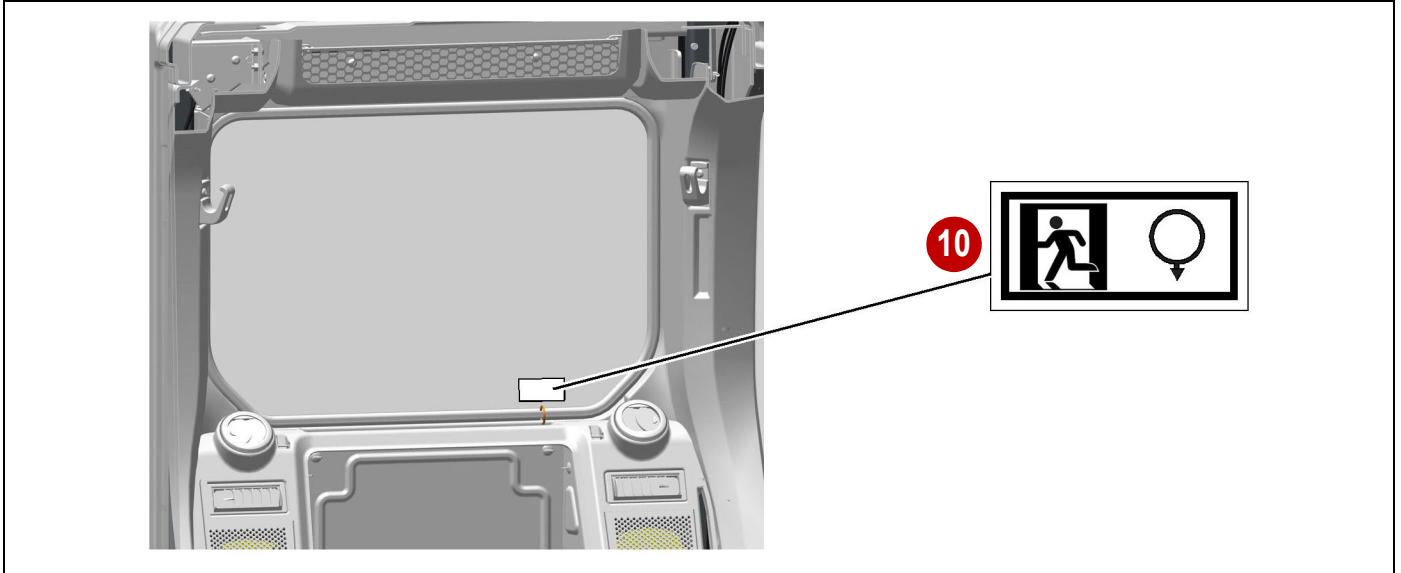

Figure 2-5

0000934

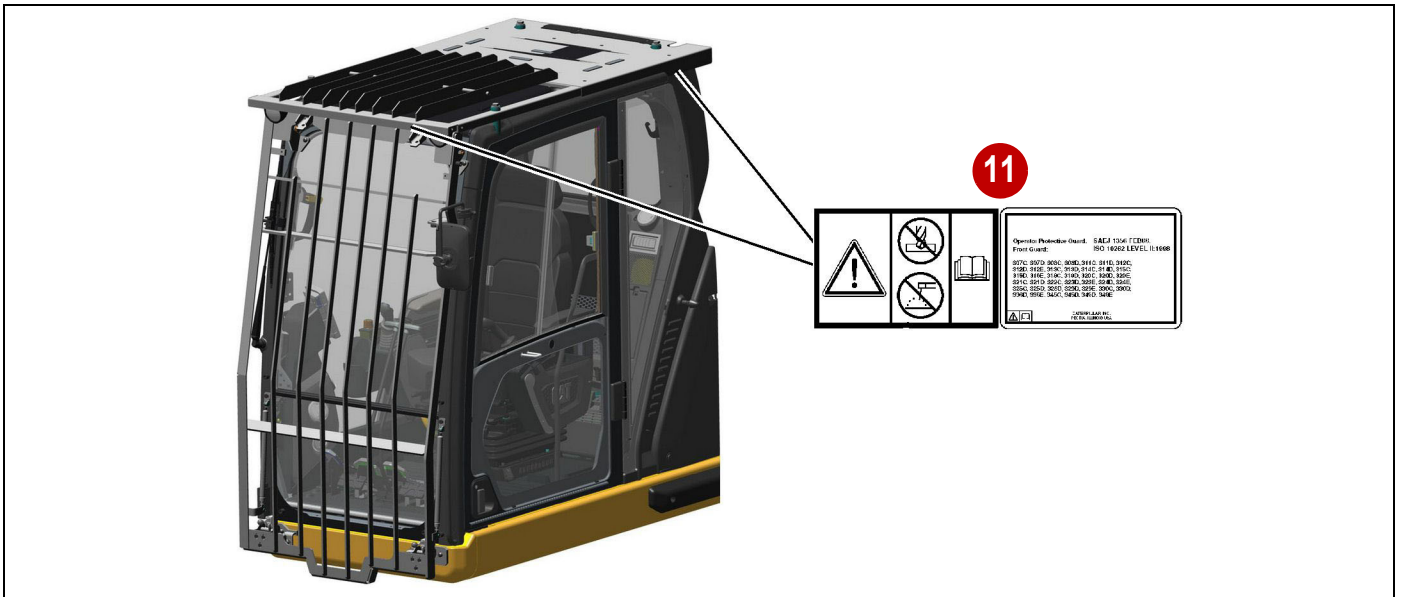

Figure 2-6

0000926

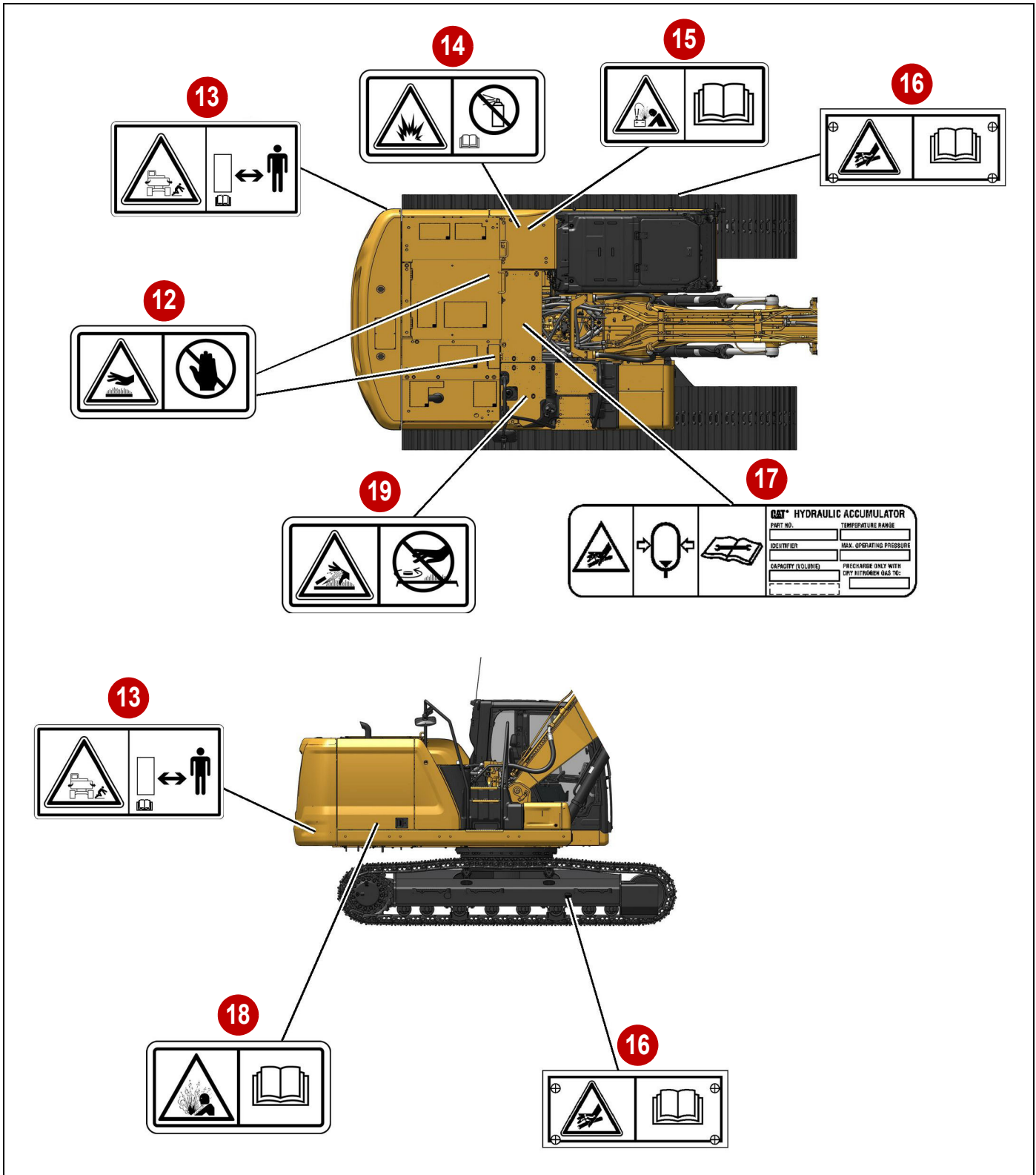

Figure 2-7

0000925

Crushing Hazard* (1)

This safety message located on the left and right side cab windows.

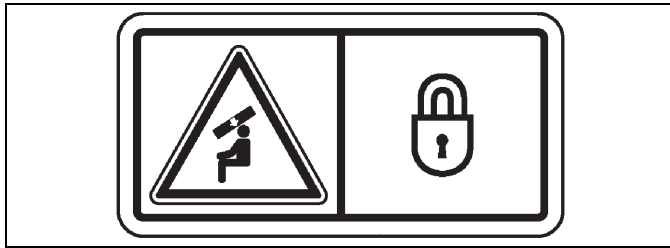

Figure 2-8

g02061339

⚠️ WARNING

Personal injury can result if the window is not latched in the overhead position; ensure the auto lock is engaged.

Product Link* (2)

If equipped, this safety message is located in the cab on the right side window.

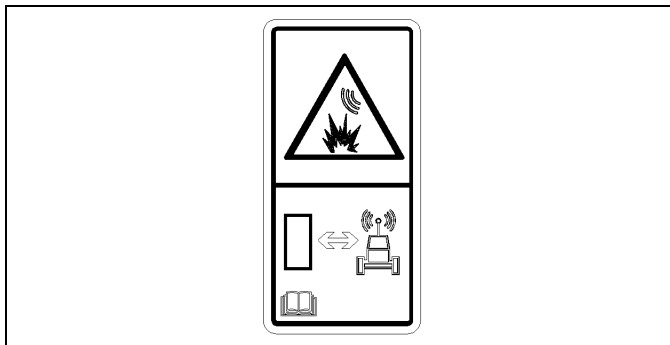

Figure 2-9

0000927

⚠️ WARNING

This machine is equipped with a Caterpillar Product Link communication device. When electric detonators are used, this communication device should be deactivated within 12 m (40 ft) of a blast site for satellite-based systems and within 3 m (10 ft) of a blast site for cellular based systems, or within the distance mandated under applicable legal requirements. Failure to do so could cause interference with blasting operations and result in serious injury or death. In cases where the type of Product Link module cannot be identified, Caterpillar recommends that the device be disabled no less than 12 m (40 ft) from the blast perimeter.

Refer to “Product Link*” on page 7-5 for additional information.

Do Not Operate* (3)

This safety message is located in the cab on the right side window.

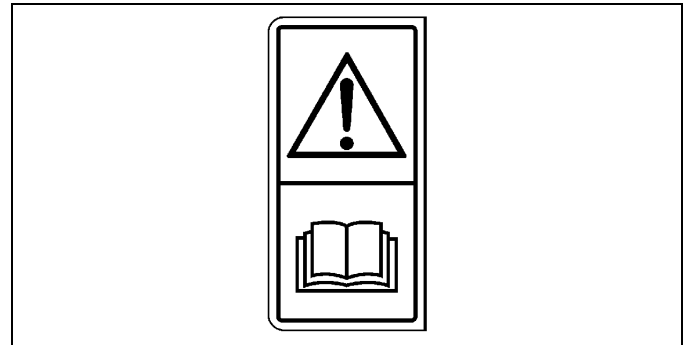

Figure 2-10

0000928

⚠️ WARNING

Do not operate or work on this machine unless you have read and understand the instructions and warnings in the Operation and Maintenance Manual. Failure to follow the instructions or heed the warnings could result in injury or death. Contact any Caterpillar dealer for replacement manuals. Proper care is your responsibility.

Seat Belt* (4)**⚠️ WARNING**

A seat belt should be worn at all times during machine operation to prevent serious injury or death in the event of an accident or machine overturn. Failure to wear a seat belt during machine operation may result in serious injury or death.

This safety message is located in the cab on the right side window.



Figure 2-11

g06188642

SAFETY

Crushing Hazard* (5)

This safety message is located in the cab on the right side window.

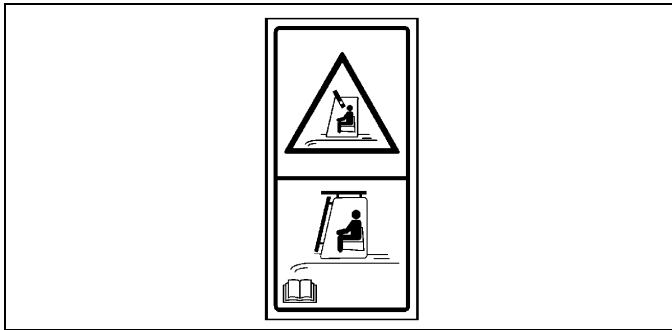

Figure 2-12

0000929

⚠️ WARNING

The impact from objects that strike the front of the cab or the top of the cab could result in a crushing hazard with the potential for personal injury or death. The front guard and the top guard should be installed on the cab for applications where the hazard of falling objects exist. Read the Operation and Maintenance Manual.

Electrical Power Lines* (6)

This safety message is located in the cab.

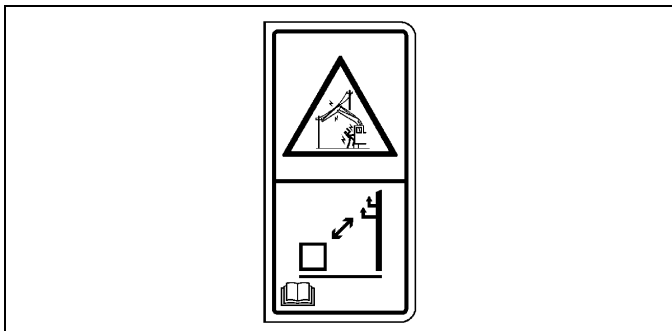

Figure 2-13

0000930

⚠️ WARNING

Electrocution Hazard! Keep the machine and attachments a safe distance from electrical power. Stay clear 3 m (10 ft) plus twice the line insulator length. Read and understand the instructions and warnings in the Operation and Maintenance Manual. Failure to follow the instructions and warnings will cause serious injury or death.

Refer to “Above Ground Hazards” on page 2-30 for additional information.

Do Not Weld or Drill on ROPS* (7)

This safety message is located in the cab on the right side window.



Figure 2-14

0000931

⚠️ WARNING

Structural damage, an overturn, modification, alteration, or improper repair, can impair this structure's protective capability thereby voiding this certification. Do not weld on or drill holes in the structure. Consult a Caterpillar dealer to determine this structure's limitations without voiding its certification.

Certification for Rollover Protective Structure (ROPS) and for Falling Object Protective Structure (FOPS):

The unaltered ROPS or the FOPS structure meets the following standards for the ROPS at the time of installation: ISO 3471-2008 and GB/T 17922-2014. Also, the FOPS canopy meets the following standards at the time of installation: ISO 3449-2005 LEVEL II and GB/T 17771-2010 LEVEL II.

This machine has been certified to the standards that are listed on the certification plate. The maximum mass of the machine, which includes the operator and the attachments without a payload, should not exceed the mass on the certification plate.

Refer to “Guards” on page 2-35 for additional information.

Front Window Usage* (8)

For machines equipped with the Cat Grade Control monitor, the monitor must be moved downward before lifting or lowering the front window. The monitor is in the path of the window track in its normal position.

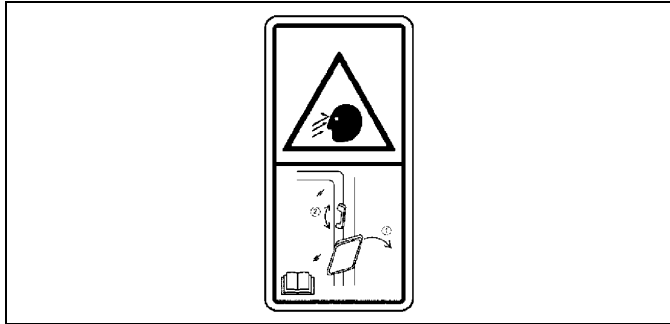

Figure 2-15

0000936

Data Privacy* (9)

The Product Link System is a satellite communication device that transmits information regarding the machine back to Caterpillar and Cat dealers and customers. All logged events and diagnostic codes that are available to the Cat Electronic Technician (ET) on the Cat data link can be sent to the satellite. Information can also be sent to the Product Link System. The information is used to improve Cat products and Cat services.

Refer to “Product Link*” on page 7-5 for additional information.

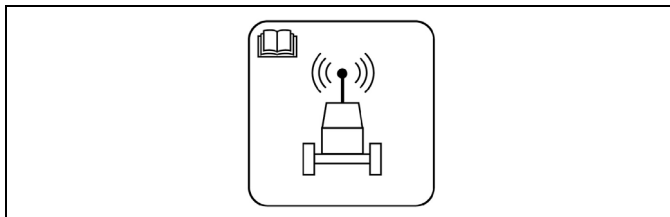

Figure 2-16

0000937

Alternate Exit* (10)

If equipped, this message is on the rear window of the cab in the lower left-hand corner.

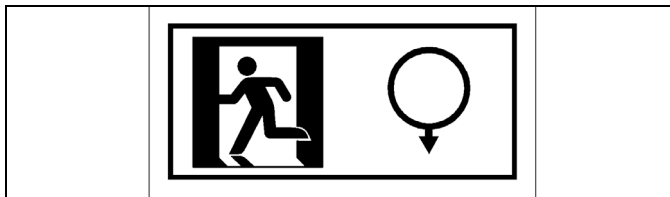

Figure 2-17

0000938

Pull the ring to pull out the seal. Push the window out of the cab and exit through the opening.

Refer to “Alternate Exit*” on page 7-3 for additional information.

Falling Object Guard Structure* (11)

If equipped, this safety message is on top of the front falling object guard structure. This safety message is also on the left side of the falling object guard structure on the top of the cab.

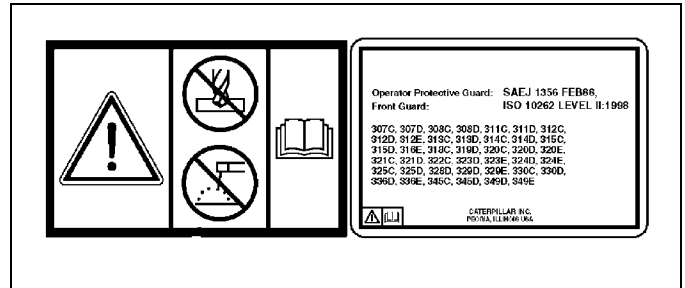

Figure 2-18

g02428757

WARNING

Structural damage, an overturn, modification, alteration, or improper repair can impair this structure's protection capability, thereby voiding this certification. Do not weld on or drill holes in the structure. Consult a Caterpillar dealer to determine this structure's limitations without voiding its certification.

Hot Surface* (12)

This message is on the outside of the engine hood and on the inside of the engine hood.



Figure 2-19

g01372256

WARNING

Engine hood and engine hood parts can be hot while engine is running or immediately after engine shutdown. Hot parts or hot components can cause burns or personal injury. Do not allow these parts to contact your skin when engine is running or immediately after engine shutdown. Use protective clothing or protective equipment to protect your skin.

SAFETY

Crushing Hazard* (13)

This safety message is on the rear of each side of the machine.

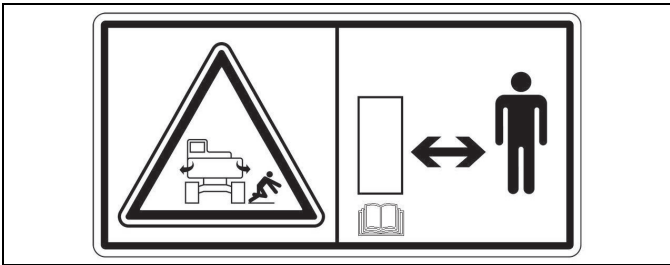

Figure 2-20

g06219420

⚠️ WARNING

Machine swings. Stay back. Crushing hazard could cause serious injury or death.

Aerosol Starting Aid* (14)

This safety message is located near the precleaner. The following information is not applicable to machines that are equipped with an ether starting aid.



Figure 2-21

g01372254

⚠️ WARNING

Explosion hazard! Do NOT use ether! This machine is equipped with an air inlet heater. Using ether can create explosions or fires that can cause personal injury or death. Read and follow the starting procedure in the Operation and Maintenance Manual.

Jump-Start Cables* (15)

This safety message is positioned on the circuit breaker panel.

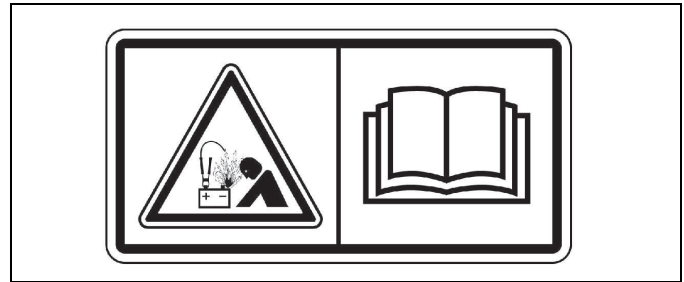

Figure 2-22

g01370909

⚠️ WARNING

Explosion Hazard! Improper jumper cable connections can cause an explosion resulting in serious injury or death. Batteries may be located in separate compartments. Refer to the Operation and Maintenance Manual for the correct jump starting procedure.

Crush Hazard* (16)

This safety message is on the back of both the track adjuster covers.

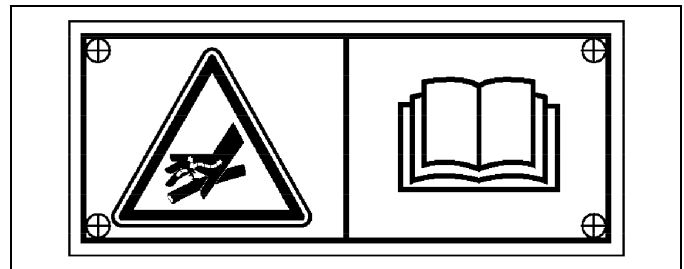

Figure 2-23

0000950

⚠️ WARNING

Personal injury or death can result from grease under pressure. Grease coming out of the relief valve under pressure can penetrate the body causing injury or death.

Do not watch the relief valve to see if grease is escaping. Watch the track or track adjustment cylinder to see if the track is being loosened.

Loosen the relief valve one turn only.

If track does not loosen, close the relief valve and contact your Cat dealer.

⚠ WARNING

Recoil system contains high-pressure nitrogen cylinder. Parts can separate with explosive force if proper care is not used during disassembly.

This action can cause serious injury or death.

Do not disassemble any part of this cylinder until you have read and understand the instructions given in the service manual. Observe the instructions given in the service manual.

High-Pressure Gas* (17)

This safety message is positioned on the accumulator.

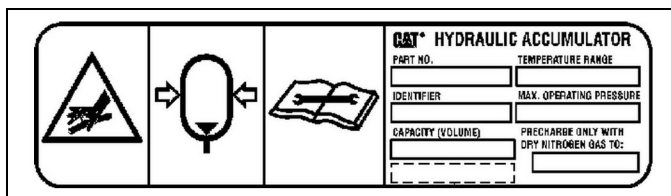

Figure 2-24

0000932

⚠ WARNING**Pressurized System!**

Hydraulic accumulators contain gas and oil under high-pressure. Do NOT disconnect lines or disassemble any component of a pressurized accumulator. All gas pre-charge must be removed from the accumulator as instructed by the service manual before servicing or disposing of the accumulator or any accumulator component.

Failure to follow the instructions and warnings could result in personal injury or death.

Only use dry nitrogen gas to recharge accumulators. See your CAT[®] dealer for special equipment and detailed information for accumulator service and charging.

Refer to “Release of Hydraulic Pressure from the Main Hydraulic System*” on page 10-66 for additional information.

Vapor Explosion* (18)

If equipped, this safety message is on the storage compartment for the fuel transfer pump.



Figure 2-25

g01407639

⚠ WARNING

Explosion hazard! Fuel vapors can accumulate in the refueling pump compartment and can be ignited by improper operation of the refueling pump. Failure to follow the operating instructions for the refueling pump could result in personal injury or death. Read and follow the operating instructions for the refueling pump in the Operation and Maintenance Manual.

Refer to “Fuel Transfer Pump (Refueling) (If Equipped)”** on page 7-10 for additional information.

Relieve Hydraulic Tank Pressure* (19)

This safety message is on top of the hydraulic tank.



Figure 2-26

g01371640

⚠ WARNING**Hot Fluid Under Pressure!**

Do NOT remove pressure cap when hot. Hot oil could cause serious injury or death.

Refer to “Release of Hydraulic Pressure from the Main Hydraulic System*” on page 10-66 for additional information.

SAFETY

Additional Safety Decals

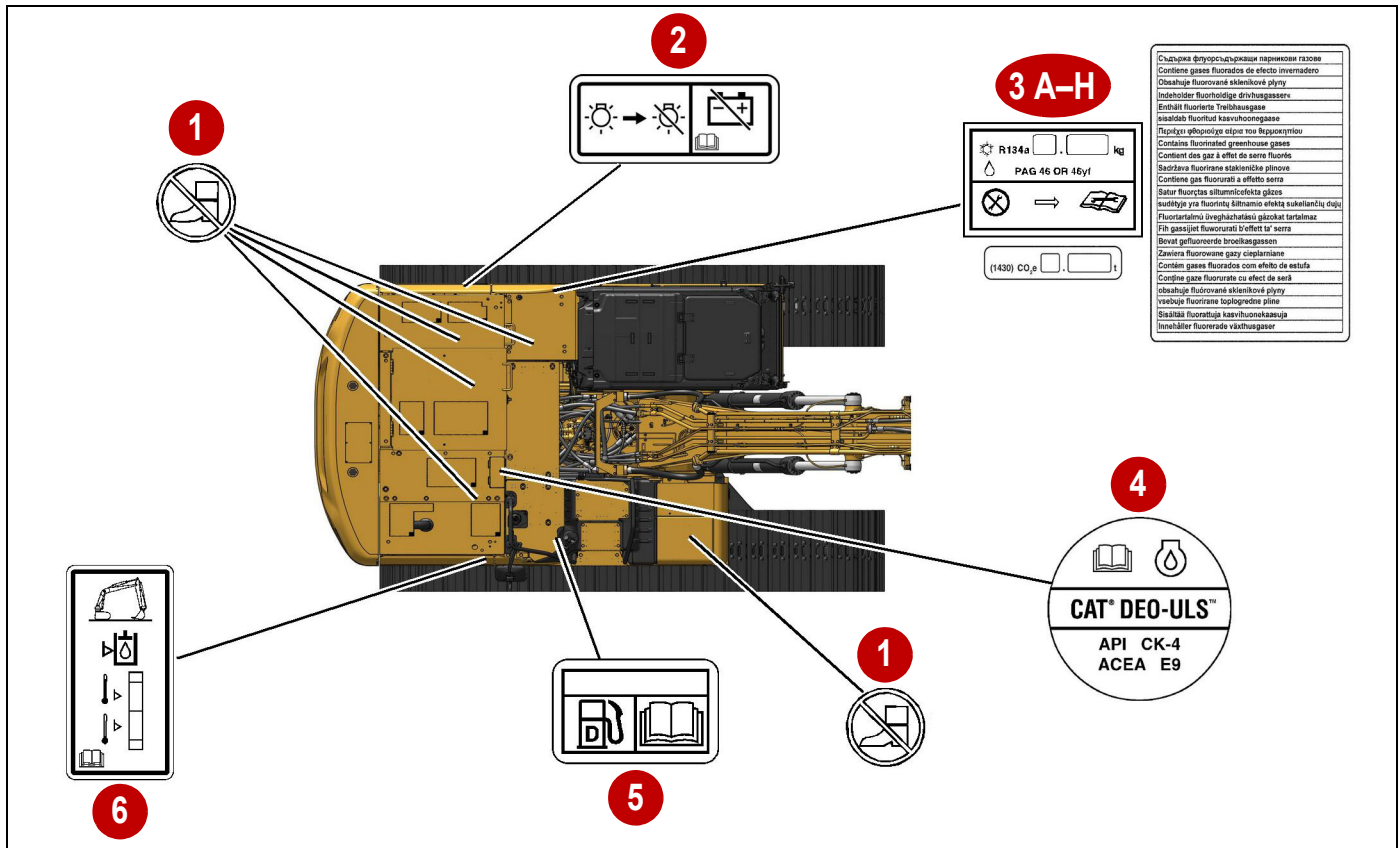

Figure 2-27

0000935

No Step* (1)

This message is on various places on the upper structure and covers. It is also on the engine valve cover.

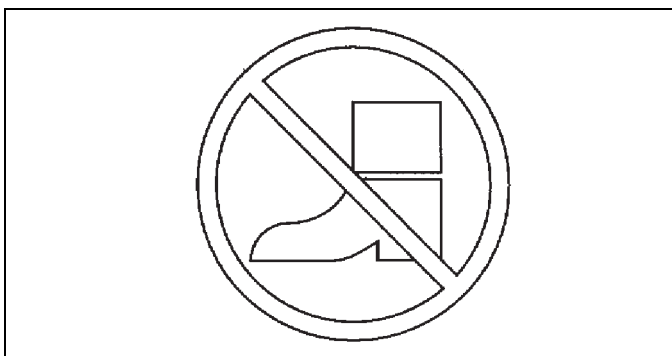

Figure 2-28

g00911158

Do not step in this area.

DEF Purge Indicator Lamp* (2)

This message is located behind the cab near the disconnect switch and pertains to the diesel exhaust fluid (DEF) system.

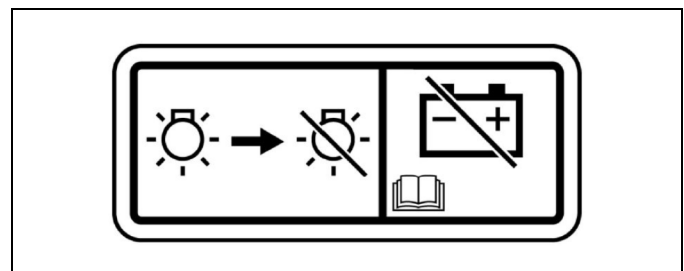

Figure 2-29

0000949

NOTICE

After the engine is shut down, apply the battery disconnect switch. Applying the battery disconnect too soon will prevent the DEF system from being purged and could cause DEF to freeze in the lines.

Air Conditioner* (3 A–H)

These messages are positioned on the left door behind the cab.

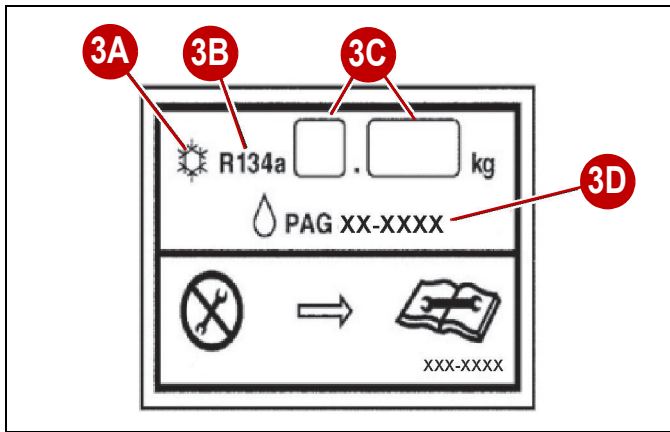

Figure 2-30

g06214936

- (3A) Air conditioning symbol
- (3B) R134a (Refrigerant type common name)
- (3C) Refrigerant quantity
- (3D) PAG (polypropylene glycol) lubricating oil part number

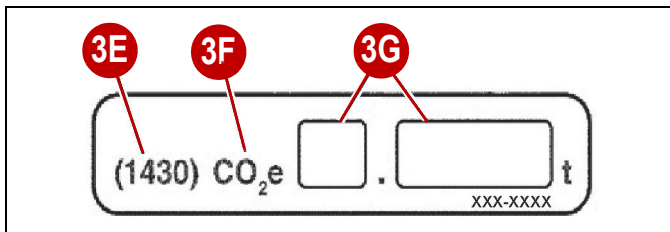

Figure 2-31

g06214938

If equipped, this plate provides the below additional European Union required greenhouse gas information.

- (3E) (1430) This is the Global Warming Potential of R134a
- (3F) CO₂ equivalent
- (3G) The system contains 1.430 metric tonne of CO₂ equivalent

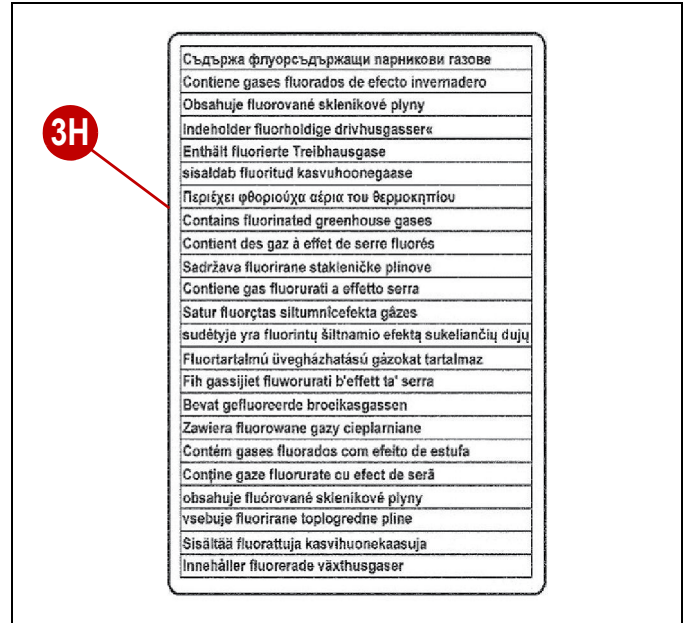

Figure 2-32

0000957

(3H) If equipped, this film provides the required language translations of the text “Contains fluorinated greenhouse gases” for the European Union greenhouse gas regulation.

These messages for the air conditioner system have the appropriate information for the following services: the air conditioner lubricant, the refrigerant charge, and the refrigerant capacity.

Engine Oil Requirements* (4)

This message is on top of the engine.

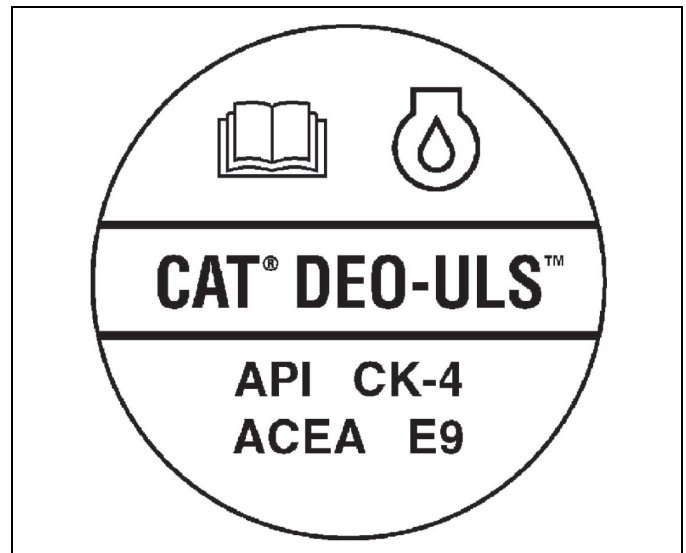

Figure 2-33

g06208149

SAFETY

Diesel Fuel Requirements* (5)

This message is located by the fuel tank.

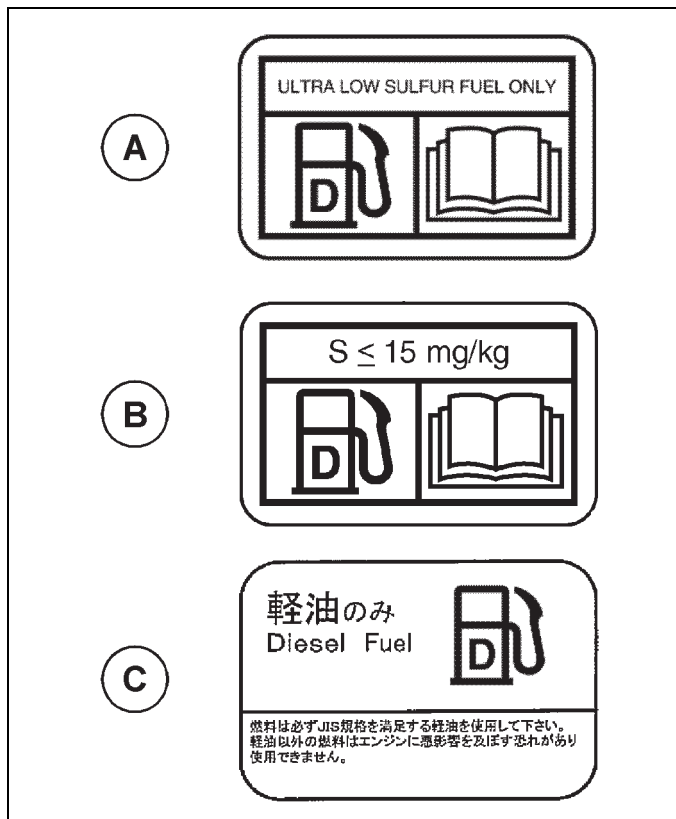

Figure 2-34

g03218956

(A) North America film

(B) Europe, Africa, Middle East film

(C) Japan film

Hydraulic Oil Level Check* (6)

This message is located in the right access compartment next to the sight gauge for the hydraulic oil.

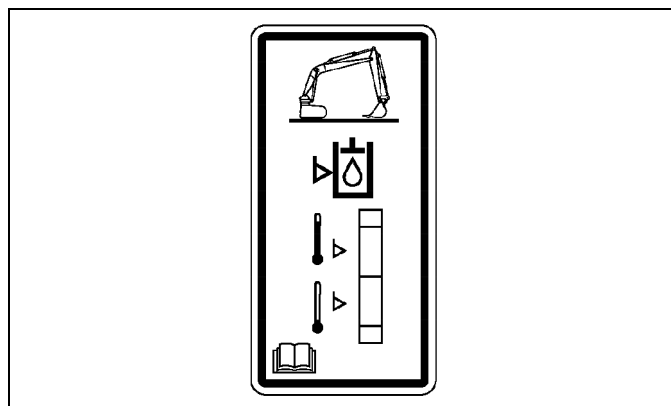

Figure 2-35

0000948

Check hydraulic oil level daily. See “Hydraulic System Oil Level – Check*” on page 10-74 for details.

The maximum air pressure for cleaning purposes must be reduced to 205 kPa (30 psi) when the nozzle is deadheaded and the nozzle is used with an effective chip deflector and personal protective equipment. The maximum water pressure for cleaning purposes must be below 275 kPa (40 psi).

Avoid direct spraying of water on electrical connectors, connections, and components. When using air for cleaning, allow the machine to cool to reduce the possibility of fine debris igniting when redeposited on hot surfaces.

Hazard Prevention

NOTICE

CZM cannot foresee all the circumstances that may involve a hazard. Therefore, the hazard alerts in this manual and on the drilling rig may not include all possible safety precautions.

Health and First Aid

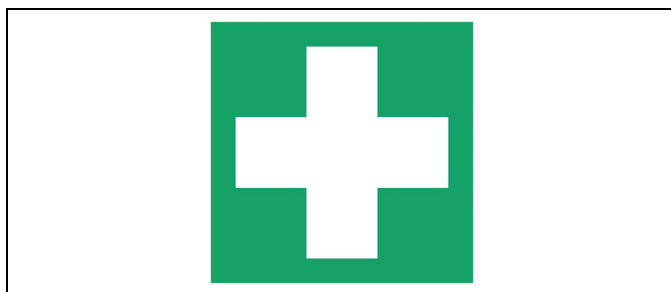

Figure 2-36

0000958

At each construction site, at least one operator for each team must be trained to be able to intervene in case of an accident.

Training must be entrusted to competent and experienced staff. The designated operator must know how to recognize and provide for the first intervention in case of:

- Eye injuries
- Cuts, bruises, and abrasions to the skin surface
- Fractures
- Burns
- Inhalation of toxic materials
- Collapses
- Heart attacks
- Electric shocks

Contact with Fluids

If you are injured by a fluid leak, seek immediate medical attention. If proper treatment is not taken immediately, infections or serious reactions could develop.

Avoid skin contact with any kind of fuel, lubricant, acid, solvent, and so on, since most of them contain substances that can be harmful to health.

Avoid prolonged and repeated contact of the skin with used motor oils; such contact can cause serious skin diseases or other serious physical injuries.

A jet of fuel or oil at high-pressure can cause serious physical injury.

Fluids having anti-corrosion properties contain an alkaline substance:

- Avoid contact with the eyes. In case of contact with the eyes, immediately rinse the eyes with plenty of running water for at least 15 minutes and seek medical attention immediately.
- Avoid prolonged and repeated contact with skin.
- Do not ingest the product.

Diesel fuel and methyl ethyl ketone (MEK) are flammable substances and must be used with caution. Follow the manufacturer's instructions to ensure maximum safety.

Cooling fluids:

- If any coolant gets into your eyes, wash them immediately in cold water for at least 5 minutes and seek medical attention immediately.
- If any air conditioning coolant gets on your skin, use the same treatment for freezing. Warm the affected area with your hand or with warm water, cover with a loose bandage to protect the affected area from infections, and seek medical attention immediately.

Batteries contain sulfuric acid. Protect your eyes when working near batteries to avoid possible splashing of the acid solution. If the acid comes into contact with the skin, eyes, or clothes, rinse immediately with water for a minimum of 15 minutes. Seek immediate medical attention.

Electrocution

In case of emergency and awaiting the arrival of medical personnel, apply the following general instructions for providing first aid:

- Do not touch the injured person with bare hands until you are sure that the same can be detached from the voltage source.
- Turn off the voltage source if the injured person is still in contact with the voltage.
- Do not give liquids to the injured person under any circumstances.

SAFETY

Lines, Tubes, and Hoses*

Do not bend high-pressure lines. Do not strike high-pressure lines. Do not install any lines that are bent or damaged. Use the appropriate backup wrenches in order to tighten all connections to the recommended torque.

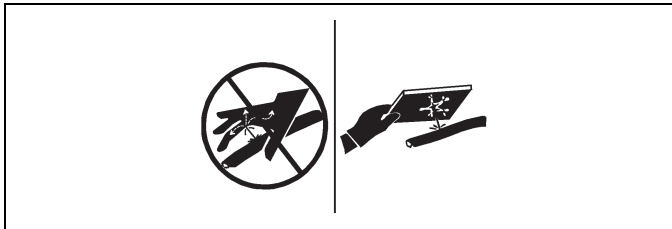

Figure 2-37

g00687600

Check lines, tubes, and hoses carefully. Wear personal protective equipment (PPE) in order to check for leaks. Always use a board or cardboard when you check for a leak. Leaking fluid that is under pressure can penetrate body tissue. Fluid penetration can cause serious injury and possible death. A pin hole leak can cause severe injury. If fluid is injected into your skin, you must get treatment immediately.

Seek treatment from a doctor that is familiar with this type of injury.

Replace the affected parts if any of the following conditions are present:

- End fittings are damaged or leaking.
- Outer coverings are chafed or cut.
- Wires are exposed.
- Outer coverings are swelling or ballooning.
- Flexible parts of the hoses are kinked.
- Outer covers have exposed embedded armoring.
- End fittings are displaced.

Make sure that all clamps, guards, and heat shields are installed correctly. During machine operation, this will help to prevent vibration, rubbing against other parts, excessive heat, and failure of lines, tubes, and hoses.

Do not operate a machine when a fire hazard exists. Repair any lines that are corroded, loose, or damaged. Leaks may provide fuel for fires. Consult your CAT® dealer for repair or for replacement parts. Use genuine CAT® parts or the equivalent for capabilities of both the pressure limit and temperature limit.

Pressurized Hydraulic Oil Lines

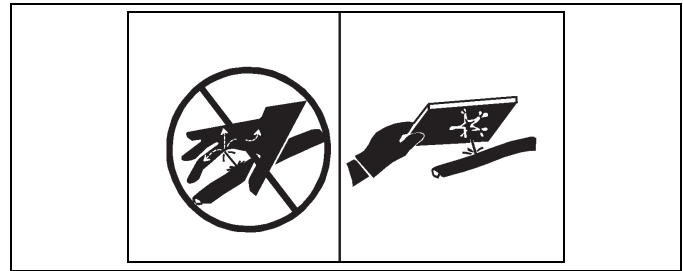

Figure 2-38

g00687600

⚠ WARNING

- Never perform repairs to items while any system is under pressure.
- Never use hands to check or feel for leaks.
- Always wear safety glasses and leather gloves, and use a piece of wood or cardboard to check for leaks.
- If high-pressure fluids penetrate skin, seek medical attention immediately.

Failure to follow these warnings can result in death or serious injury.

⚠ WARNING

- Stop the engine immediately in the event of a hydraulic oil leak.
- Pressurized hydraulic oil may be hot and could cause burns. The hydraulic oil tank may be under pressure, and hydraulic oil may be present at the filler cap. Allow the hydraulic system to cool and relieve hydraulic system pressure before maintenance to prevent injury.
- Do not bend high-pressure lines.
- Do not strike high-pressure lines.
- Do not install any lines that are bent or damaged.

Failure to follow these warnings could result in injury, equipment malfunction, or damage to the environment.

The drilling rig operates with high-pressure hydraulic oil hoses. Avoid working on or performing maintenance near hydraulic oil hoses when they are pressurized.

Make sure that the hydraulic systems do not have a load supported by hydraulic oil pressure on them before opening the hydraulic system.

Replace lines and hoses immediately if leaks, swelling, cracking, or a failure occurs. See "Maintenance Plan" on page 10-7.

High-Pressure Fuel Lines*

SMCS Code: 1000; 1274; 7000

WARNING

- **Contact with high-pressure fuel may cause fluid penetration and burn hazards.**
- **High-pressure fuel spray may cause a fire hazard.**

Failure to follow this warning could result in death or serious injury.

The high-pressure fuel lines are the fuel lines that are between the high-pressure fuel pump and the high-pressure fuel manifold and also the fuel lines that are between the fuel manifold and cylinder head. These fuel lines are different from fuel lines on other fuel systems.

This is because of the following differences:

- The high-pressure fuel lines are constantly charged with high-pressure.
- The internal pressures of the high-pressure fuel lines are higher than other types of fuel system.
- The high-pressure fuel lines are formed to shape and then strengthened by a special process.

Consequently:

- Do not step on the high-pressure fuel lines.
- Do not deflect the high-pressure fuel lines.
- Do not bend or strike the high-pressure fuel lines.

NOTE: *Deformation or damage of the high-pressure fuel lines may cause a point of weakness and potential failure.*

- Do not check the high-pressure fuel lines with the engine or the starting motor in operation.

NOTE: *After the engine has stopped, allow 10 minutes to pass in order to allow the pressure to be purged before any service or repair is performed on the engine fuel lines.*

- Do not loosen the high-pressure fuel lines in order to remove air from the fuel system. This procedure is not required.
- Visually inspect the high-pressure fuel lines before the engine is started. This inspection should be each day.

If you inspect the engine in operation, always use the proper inspection procedure in order to avoid a fluid penetration hazard:

- Inspect the high-pressure fuel lines for damage, deformation, nicks, cuts, creases, or dents.
- Do not operate the engine with a fuel leak. If there is a leak, do not tighten the connection in order to stop the leak. The connection must only be tightened to the recommended torque. Refer to Disassembly and Assembly for your engine.
- If the high-pressure fuel lines are torqued correctly and the high-pressure fuel lines are leaking, the high-pressure fuel lines must be replaced.
- Ensure that all clips on the high-pressure fuel lines are in place. Do not operate the engine with clips that are damaged, missing, or loose.
- Do not attach any other item to the high-pressure fuel lines.

Loosened high-pressure fuel lines must be replaced. Also, removed high-pressure fuel lines must be replaced. Refer to Disassembly and Assembly for your engine.

Accumulator Safety

WARNING

Never open a hydraulic component under pressure. Escaping hydraulic oil is under high-pressure and can penetrate the skin and cause serious injury or death. Do not use hands to check for leaks. Wear gloves, eye protection, and other personal protective equipment (PPE) and use a piece of cardboard or paper to search for suspected leaks.

Hydraulic accumulators contain nitrogen gas and hydraulic oil under high-pressure. Do NOT disconnect lines or disassemble any component of a pressurized accumulator. All gas pre-charge must be removed from the accumulator as instructed by the service manual before servicing or disposing of the accumulator or any accumulator component.

Only use dry nitrogen gas to recharge accumulators. See your CAT® dealer for special equipment and detailed information for accumulator service and discharging.

Failure to follow the instructions and warnings could result in personal injury or death.

This machine is equipped with an accumulator charged with high-pressure nitrogen gas. Do not disassemble the accumulator:

- Never expose the accumulator to temperatures over 140°F (60°C) or to open flames.
- Never weld on the accumulator.
- Never strike the accumulator.

Track*

SMCS Code: 4170; 7000

Track adjusting systems use either grease or oil under high-pressure to keep the track under tension.

Grease or oil under high-pressure coming out of the relief valve can penetrate the body causing injury or death. Do not watch the relief valve to see if grease or oil is escaping. Watch the track or track adjustment cylinder to see if the track is being loosened.

The pins and bushings in a dry track pin joint can become very hot. It is possible to burn the fingers if there is more than brief contact with these components.

Pressurized Air and Water*

Pressurized air and/or water can cause debris and/or hot water to be blown out. The debris and/or hot water could result in personal injury.

When pressurized air and/or pressurized water is used for cleaning, wear protective clothing, protective shoes, and eye protection. Eye protection includes goggles or a protective face shield.

The maximum air pressure for cleaning purposes must be reduced to 205 kPa (30 psi) when the nozzle is deadheaded and the nozzle is used with an effective chip deflector and personal protective equipment.

The maximum water pressure for cleaning purposes must be below 275 kPa (40 psi).

Avoid direct spraying of water on electrical connectors, connections, and components. When using air for cleaning, allow the machine to cool to reduce the possibility of fine debris igniting when redeposited on hot surfaces.

Pressurized air and/or water can cause debris and/or hot water to be blown out. The debris and/or hot water could result in personal injury.

Trapped Pressure*

Pressure can be trapped in a hydraulic system. Releasing trapped pressure can cause sudden machine movement or attachment movement. Use caution if you disconnect hydraulic lines or fittings. High-pressure oil that is released can cause a hose to whip. High-pressure oil that is released can cause oil to spray. Fluid penetration can cause serious injury and possible death.

Fluid Penetration*

Pressure can be trapped in the hydraulic circuit long after the machine has been stopped. The pressure can cause hydraulic fluid or items such as pipe plugs to escape rapidly if the pressure is not relieved correctly.

Do not remove any hydraulic components or parts until pressure has been relieved or personal injury may occur. Do not disassemble any hydraulic components or parts until pressure has been relieved or personal injury may occur. Refer to the Service Manual for any procedures that are required to relieve the hydraulic pressure.

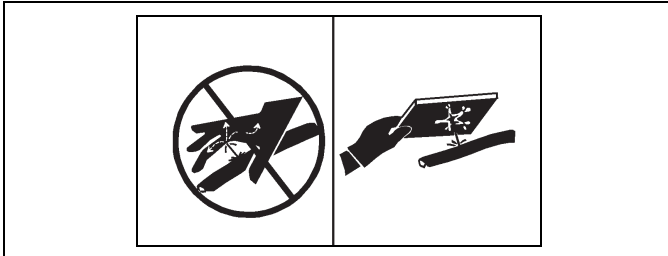

Figure 2-39

g00687600

Always use a board or cardboard when you check for a leak. Leaking fluid that is under pressure can penetrate body tissue. Fluid penetration can cause serious injury and possible death. A pin hole leak can cause severe injury. If fluid is injected into your skin, you must get treatment immediately. Seek treatment from a doctor that is familiar with this type of injury.

Containing Fluid Spillage*

The following care must be taken to ensure that fluids are contained during the performance of inspection, maintenance, testing, adjusting, and repair of the equipment:

- Prepare to collect the fluid with suitable containers before opening any compartment or disassembling any component that contains fluids.
- Obey all local regulations for the disposal of liquids.

Inhalation

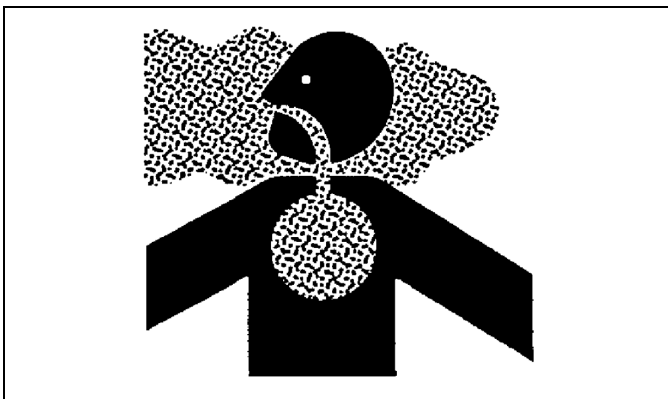

Figure 2-40

0000829

Exhaust

⚠ WARNING

Exhaust fumes can be hazardous to your health. If you operate the machine in an enclosed area, adequate ventilation is necessary. Failure to follow this warning may result in death or serious injury.

Asbestos

⚠ WARNING

Avoid inhaling dust that might be generated when you handle components that contain asbestos fibers. Inhaling this dust can be hazardous to your health. Failure to follow this warning may result in death or serious injury.

The components that may contain asbestos fibers are:

- Brake pads
- Brake bands
- Lining material
- Clutch plates
- Some gaskets

NOTICE

The asbestos that is used in these components is bound in a resin or sealed in some way. Normal handling is not hazardous unless airborne dust that contains asbestos is generated.

If dust that may contain asbestos is present, several guidelines should be followed:

- Never use compressed air for cleaning.
- Avoid brushing materials that contain asbestos.
- Avoid grinding materials that contain asbestos.
- Use a wet method to clean up asbestos materials. A vacuum cleaner that is equipped with a high-efficiency particulate air filter (HEPA) can also be used.
- Use exhaust ventilation on permanent machining jobs. Wear an approved respirator if there is no other way to control the dust.
- Comply with applicable rules and regulations for the workplace. In the United States, use Occupational Safety and Health Administration (OSHA) requirements. These OSHA requirements can be found in "29 CFR 1910.1001". In Japan, use the requirements found in the "Ordinance on Prevention of

SAFETY

Health Impairment due to Asbestos” in addition to the requirements of the Industrial Safety and Health Act.

- Obey environmental regulations for the disposal of asbestos.
- Stay away from areas that might have asbestos particles in the air.

Crushing Prevention and Cutting Prevention*

SMCS Code: 7000

Support the equipment properly before you perform any work or maintenance beneath that equipment. Do not depend on the hydraulic cylinders to hold up the equipment. Equipment can fall if a control is moved or if a hydraulic line breaks.

Do not work beneath the cab of the machine unless the cab is properly supported.

Unless you are instructed otherwise, never attempt adjustments while the machine is moving or while the engine is running.

Never jump across the starter solenoid terminals in order to start the engine. Unexpected machine movement could result.

Wherever there are equipment control linkages, the clearance in the linkage area will change with the movement of the equipment or the machine. Stay clear of areas that may have a sudden change in clearance with machine movement or equipment movement.

Stay clear of all rotating and moving parts.

If it is necessary to remove guards in order to perform maintenance, always install the guards after the maintenance is performed.

Keep objects away from moving fan blades. The fan blade will throw objects or cut objects.

Do not use a kinked wire cable or a frayed wire cable. Wear gloves when you handle wire cable.

When you strike a retainer pin with force, the retainer pin can fly out. The loose retainer pin can injure personnel. Make sure that the area is clear of people when you strike a retainer pin. To avoid injury to your eyes, wear protective glasses when you strike a retainer pin.

Chips or other debris can fly off an object when you strike the object. Make sure that no one can be injured by flying debris before striking any object.

Burn Prevention*

SMCS Code: 7000

Do not touch any part of an operating engine. Allow the engine to cool before any maintenance is performed on the engine. Relieve all pressure in the air system, in the oil system, in the lubrication system, in the fuel system, or in the cooling system before any lines, fittings, or related items are disconnected.

Coolant*

WARNING

- **Any contact with hot coolant or with steam can cause severe burns. Allow cooling system components to cool before the cooling system is drained.**
- **Cooling system conditioner contains alkali. Alkali can cause personal injury. Do not allow alkali to contact the skin, the eyes, or the mouth.**

Failure to follow these warnings may result in death or serious injury.

When the engine is at operating temperature, the engine coolant is hot. The coolant is also under pressure. The radiator and all lines to the heaters or to the engine contain hot coolant.

Check the coolant level only after the engine has been stopped.

Ensure that the filler cap is cool before removing the filler cap. The filler cap must be cool enough to touch with a bare hand. Remove the filler cap slowly in order to relieve pressure.

Oils*

WARNING

Hot oil and hot components can cause personal injury. Do not allow hot oil to contact the skin. Also, do not allow hot components to contact the skin. Failure to follow this warning may cause severe injury.

Remove the hydraulic tank filler cap only after the engine has been stopped. The filler cap must be cool enough to touch with a bare hand. Follow the standard procedure in this manual in order to remove the hydraulic tank filler cap.

Battery Safety

Batteries*

⚠ WARNING

Before proceeding with any battery maintenance procedure, observe the following precautions:

- Wear personal protective equipment (PPE) when servicing batteries.
- Keep the top of the battery clean to prevent plugging of the battery vents.
- Battery gases are explosive. Work in a well-ventilated area. Avoid smoking, sparks, or open flames which could cause an explosion.

Burns can occur if battery acid makes contact with your skin or eyes. Flush the affected area immediately with fresh water and seek medical attention.

The liquid in a battery is an electrolyte. Electrolyte is an acid that can cause personal injury. Do not allow electrolyte to contact the skin or the eyes. Do not smoke while checking the battery electrolyte levels. Batteries give off flammable fumes which can explode. Always wear protective glasses when you work with batteries. Wash hands after touching batteries. The use of gloves is recommended.

i06179517

Battery Disposal

NOTICE

Dispose of batteries in accordance with all applicable environmental regulations. Failure to follow this notice could result in damage to the environment.

🌱 Always recycle a battery when possible. Never directly discard a battery.

When possible, return used batteries to:

- A battery supplier.
- An authorized battery collection facility or recycling facility.

Fire Prevention and Explosion Prevention*

SMCS Code: 7000



Figure 2-41

g0074000

Regeneration*

The exhaust gas temperatures during regeneration will be elevated. Follow proper fire prevention instructions and use the disable regeneration function (if equipped) when appropriate.

SAFETY

General Maintenance Safety*

All fuels, most lubricants, and some coolant mixtures are flammable.

To minimize the risk of fire or explosion, Caterpillar recommends the following actions:

- Always perform a Walk-Around Inspection, which may help you identify a fire hazard. Do not operate a machine when a fire hazard exists. Contact your CAT® dealer for service.
- Understand the use of the primary exit and alternative exit on the machine.
- Do not operate a machine with a fluid leak. Repair leaks and clean up fluids before resuming machine operation. Fluids that are leaking or spilled onto hot surfaces or onto electrical components can cause a fire. A fire may cause personal injury or death.
- Remove flammable material such as leaves, twigs, papers, trash, and so on. These items may accumulate in the engine compartment or around other hot areas and hot parts on the machine.
- Keep the access doors to major machine compartments closed. Access doors in working condition in order to permit the use of fire suppression equipment in case a fire should occur.
- Clean all accumulations of flammable materials such as fuel, oil, and debris from the machine.
- Do not operate the machine near any flame.
- Keep shields in place. Exhaust shields (if equipped) protect hot exhaust components from oil spray or fuel spray in a break in a line, in a hose, or in a seal. Exhaust shields must be installed correctly.
- Do not weld or flame cut on tanks or lines that contain flammable fluids or flammable material. Empty and purge the lines and tanks. Then clean the lines and tanks with a nonflammable solvent prior to welding or flame cutting. Ensure that the components are properly grounded in order to avoid unwanted arcs.
- Dust that is generated from repairing nonmetallic hoods or fenders may be flammable and/or explosive. Repair such components in a ventilated area away from open flames or sparks. Use suitable Personal Protective Equipment (PPE).
- Inspect all lines and hoses for wear or deterioration. Replace damaged lines and hoses. The lines and the hoses should have adequate support and secure clamps. Tighten all connections to the recommended torque. Damage to the protective cover or insulation may provide fuel for fires.

- Store fuels and lubricants in properly marked containers away from unauthorized personnel. Store oily rags and flammable materials in protective containers. Do not smoke in areas that are used for storing flammable materials.

Fueling*

Fuel Tank / Vapor

⚠ WARNING

When refueling the machine:

- The ignition switch must remain off while the machine is being fueled.
- Fuel or fuel vapors that come into contact with hot surfaces or electrical components can cause a fire.
- Never service the fuel system near an open flame or while smoking.
- Clean up spilled fuel immediately.
- Fuel vapors can accumulate around the area of refueling and possibly ignite. Be sure to refuel in a well-ventilated area.

Failure to follow these warnings could result in death or serious injury.

🌱 The fuel tank cap is airtight, without a vent, to prevent releasing fuel vapor to the environment. Keep the fuel cap properly closed and do not replace it with another type.

Use caution when you are fueling a machine. Do not smoke while you are fueling a machine. Do not fuel a machine near open flames or sparks. Do not use cell phones or other electronic devices while you are refueling. Always stop the engine before fueling. Fill the fuel tank outdoors. Properly clean areas of spillage.

Avoid static electricity risk when fueling. Ultra low sulfur diesel (ULSD) poses a greater static ignition hazard than earlier diesel formulations with a higher sulfur content. Avoid death or serious injury from fire or explosion. Consult with your fuel or fuel system supplier to ensure that the delivery system is in compliance with fueling standards for proper grounding and bonding practices.

Never store flammable fluids in the operator compartment of the machine.



Figure 2-42

g03839130

SAFETY

Electrical System Maintenance

Before performing any maintenance on the electrical system, turn the battery disconnect switch to the Off position.

NOTICE

- Any welding repairs on the drilling rig must be performed by personnel who are qualified and certified to perform repairs that require welding. Owners are responsible for the structural integrity of any completed repair.
- After turning off the key switch, wait 2 minutes before disconnecting the battery. Disconnect the negative (-) battery cable from the negative (-) post of the battery prior to welding.
- The welding ground cable must be connected within 3.3 ft (1 m) of the welding area. The welding cable must be connected directly to the part being welded. Do not ground through bearings or hydraulic cylinder fasteners.

Failure to disconnect the negative battery cable could result in damage to the drilling rig or cause it to operate improperly.

Electrical System Cleaning

Clean the electrical system using approved electrical cleaners. Contact CZM product support for additional information on approved products.

Never use high-pressure water, steam, or caustic cleaners to clean the electrical system. These could damage system components and/or cause intermittent system failures.

- Remove any metal objects (such as rings, watches, or jewelry) that could come in contact with electrical circuits and cause a short-circuit.

Failure to follow these warnings could result in death or serious injury.

Always work in a well-ventilated area when working with batteries. The following are basic procedures for servicing batteries:

- Remove any battery terminal corrosion with a mixture of warm water and baking soda.
- Check the battery condition with proper test equipment.

Disconnect the Battery

When necessary to disconnect the battery during maintenance procedures, always disconnect the negative (-) cable first, then disconnect the positive (+) cable.

Disconnecting the cables between the batteries may not completely interrupt the electrical system.

Environment

Return the used battery to the dealer at the time of its replacement.

Do not dispose of a used battery in the garbage.

Points of sale locations are obliged to take back your old battery, store it in an appropriate place, and return it to the manufacturer for recycling.

The basic composition of the battery is lead, diluted sulfuric acid, and plastic. Therefore, when incorrectly discarded in nature, the acid solution and the lead contained in the battery may contaminate soil, the underground, and water, as well as cause risk to the human health.

In case of accidental contact with eyes or skin, flush with water and seek medical attention immediately.

Battery and Battery Cables*



Figure 2-43

g03839133

Caterpillar recommends the following in order to minimize the risk of fire or an explosion related to the battery.

Do not operate a machine if battery cables or related parts show signs of wear or damage. Contact your CAT® dealer for service.

Follow safe procedures for engine starting with jumpstart cables. Improper jumper cable connections can cause an explosion that may result in injury.

Do not charge a frozen battery. This may cause an explosion.

Gases from a battery can explode. Keep any open flames or sparks away from the top of a battery. Do not smoke in battery charging areas. Do not use cell phones or other electronic devices in battery charging areas.

Never check the battery charge by placing a metal object across the terminal posts. Use a voltmeter in order to check the battery charge.

Daily inspect battery cables that are in areas that are visible. Inspect cables, clips, straps, and other restraints for damage. Replace any damaged parts. Check for signs of the following, which can occur over time due to use and environmental factors:

- Fraying
- Abrasion
- Cracking
- Discoloration
- Cuts on the insulation of the cable
- Fouling
- Corroded terminals, damaged terminals, and loose terminals

Replace damaged battery cable(s) and replace any related parts. Eliminate any fouling, which may have caused insulation failure or related component damage or wear. Ensure that all components are reinstalled correctly.

An exposed wire on the battery cable may cause a short to ground if the exposed area comes into contact with a grounded surface. A battery cable short produces heat from the battery current, which may be a fire hazard.

An exposed wire on the ground cable between the battery and the disconnect switch may cause the disconnect switch to be bypassed if the exposed area comes into contact with a grounded surface. This may result in an unsafe condition for servicing the machine. Repair components or replace components before servicing the machine.

WARNING

Fire on a machine can result in personal injury or death. Exposed battery cables that come into contact with a grounded connection can result in fires. Replace cables and related parts that show signs of wear or damage. Contact your CAT® dealer.

Wiring*

Check electrical wires daily. If any of the following conditions exist, replace parts before you operate the machine:

- Fraying
- Signs of abrasion or wear
- Cracking
- Discoloration
- Cuts on insulation
- Other damage

Make sure that all clamps, guards, clips, and straps are reinstalled correctly. This will help to prevent vibration, rubbing against other parts, and excessive heat during machine operation.

Attaching electrical wiring to hoses and tubes that contain flammable fluids or combustible fluids should be avoided.

Consult your CAT® dealer for repair or for replacement parts.

Keep wiring and electrical connections free of debris.

SAFETY

Ether*

Ether (if equipped) is commonly used in cold-weather applications. Ether is flammable and poisonous.

Only use approved Ether canisters for the Ether dispensing system fitted to your machine. Do not spray Ether manually into an engine, follow the correct cold engine starting procedures.

⚠ WARNING

Manually spraying Ether into an engine with a diesel particulate filter (DPF) may result in the accumulation of Ether in the DPF and an explosion. This in conjunction with other factors may result in an injury or death.

Use ether in ventilated areas. Do not smoke while you are replacing an ether cylinder.

Do not store ether cylinders in living areas or in the operator compartment of a machine. Do not store ether cylinders in direct sunlight or in temperatures above 49°C (120.2° F). Keep ether cylinders away from open flames or sparks.

Dispose of used ether cylinders properly. Do not puncture an ether cylinder. Keep ether cylinders away from unauthorized personnel.

Fire Safety*

Fire Extinguisher Location*

SMCS Code: 7000; 7419

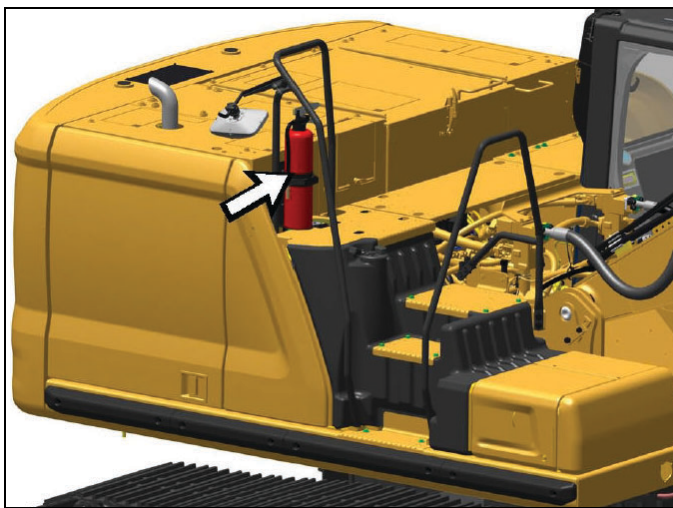

Figure 2-44

Installation of a fire extinguisher is recommended. Be familiar with the operation of the fire extinguisher. Inspect the fire extinguisher and service the fire extinguisher regularly. Obey the recommendations on the instruction plate.

The recommended location for mounting the fire extinguisher is on the upper handrail on the right side of the machine.

In Case of Fire

SMCS Code: 7000

NOTE: Locate secondary exits and learn how to use the secondary exits before you operate the machine.

NOTE: Locate fire extinguishers and how to use a fire extinguisher before you operate the machine.

If you find that you are involved in a machine fire, your safety and that of others on site are the top priority. The following actions should only be performed if the actions do not present a danger or risk to you and any nearby people. Assess the risk of personal injury and move away to a safe distance as soon as you feel unsafe.

Move the machine away from nearby combustible material such as: fuel/oil stations, structures, trash, mulch, and timber.

Lower any implements and turn off the engine as soon as possible. If you leave the engine running, the engine will continue to feed a fire. The fire will be fed from any damaged hoses that are attached to the engine or pumps.

If possible, turn the battery disconnect switch to the OFF position. Disconnecting the battery will remove the ignition source in the event of an electrical short. Disconnecting the battery will eliminate a second ignition source if electrical wiring is damaged by the fire, resulting in a short circuit.

Notify emergency personnel of the fire and your location.

If your machine is equipped with a fire suppression system, follow the manufacturer's procedure for activating the system.

NOTE: Fire suppression systems need to be regularly inspected by qualified personnel. You must be trained to operate the fire suppression system.

If you are unable to do anything else, shut off the machine before exiting. By shutting off the machine, fuels will not continue to be pumped into the fire.

If the fire grows out of control, be aware of the following risks:

Tires on wheeled machines pose a risk of explosion as tires burn. Hot shrapnel and debris can be thrown great distances in an explosion.

Tanks, accumulators, hoses, and fittings can rupture in a fire, spraying fuels and shrapnel over a large area.

Remember that nearly all the fluids on the machine are flammable, including coolant and oils. Additionally, plastics, rubbers, fabrics, and resins in fiberglass panels are also flammable.

Electrical Storm Injury Prevention*

SMCS Code: 7000

When lightning is striking in the vicinity of the machine, the operator should never attempt the following procedures:

- Mount the machine.
- Dismount the machine.

If you are in the operator's station during an electrical storm, stay in the operator's station. If you are on the ground during an electrical storm, stay away from the vicinity of the machine.

Snow and Ice

NOTICE

Remove snow and ice from the machine; in particular from safety devices such as sensors and limit switches.

Snow and ice deposits on the machine can:

- Cause unwanted effects on the machine.
- Increase the danger of falling ice fragments and blocks of snow.

Dust

The diffusion of dust can be minimized by periodically spraying the work surfaces and the travel paths of the machine with water, and also:

- Wear personal protective equipment (PPE).
- Close the door and windows of the cab. Activate the air conditioning system for adequate ventilation.
- Read and understand the Safety Data Sheet (SDS) for guidelines on the exposure risks, PPE required, proper handling and cleanup, and the correct reporting agencies if needed.

Chemicals

Chemicals at a job site present a serious danger when they are released or mishandled.

To reduce possible injury from chemicals:

- Wear personal protection equipment (PPE).
- Read and understand the Safety Data Sheet (SDS) for guidelines on the exposure risks, PPE required, proper handling and cleanup, and the correct reporting agencies if needed.

Suspended Loads

⚠ WARNING

- **Do not stand under any suspended load when using the auxiliary winch to lift authorized drilling rig equipment.**
- **Make sure suspended loads are safely controlled during lifting operations.**
- **Keep hands away from the kelly bar and other moving drilling rig components.**

Failure to follow these warnings could result in death or serious injury.

The work area must be delimited to avoid people approaching the machine during assembly, maintenance, and operation.

Periodically check the tightening of the joints, bolts, pins, and anything else subject to be loosened during use.

Do not stand under any suspended load when using the auxiliary winch to lift authorized drilling rig equipment.

Make sure suspended loads are safely controlled during lifting operations.

Any guiding of loads with ropes or rods must be at a distance of at least 2 meters from the suspended loads.

Keep hands away from the kelly bar and other moving drilling rig components.

The handling of the reinforcements must be carried out with suitable lifting equipment using the attachment points provided by the manufacturer. Use suitable harness straps and/or ropes and check them periodically.

Hooks must be equipped with devices against accidental release.

SAFETY

Work Area

General Rules

These general work rules should be followed:

- The work area must be delimited with barriers, including mobile, rigid, or flexible tapes and appropriately marked.
- Access to unauthorized personnel must be prevented.
- Keep the work area tidy. Objects left unattended can prevent and make unsafe the movement of personnel and machine.
- Fixed obstacles must be marked and/or protected (the top of finished piles, reinforcements protruding from the ground, and so on).
- An adequate lighting system must be set up in the work area. It must be implemented in compliance with the laws in force in the country in which the machine is operated.
- If you are operating near airports, respect the laws in force. Contact the regulating authorities and, if necessary, contact CZM to make any necessary changes.

Above Ground Hazards

Precautions in High-Voltage Areas

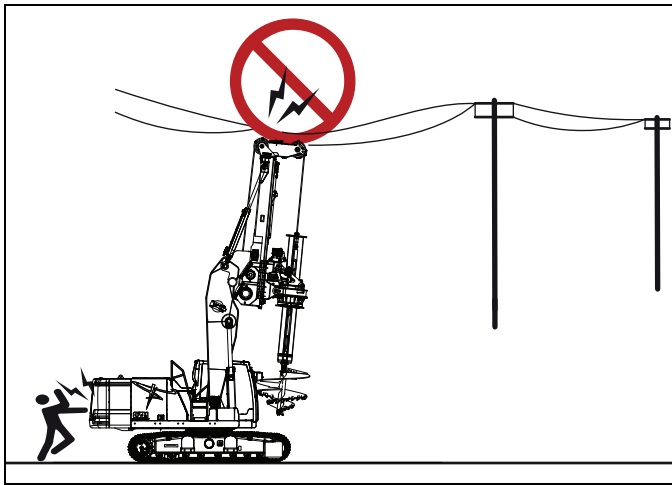

Figure 2-45 Power Lines

0000451

⚠ DANGER

- The minimum distances to be respected can change according to the country where the machine is operating. Always comply with the national and local laws.
- Avoid direct contact with high-voltage power lines while operating.

- Overhead power lines carry high-voltage electricity that can discharge to the ground through the drilling rig; with or without direct contact with the drilling rig structure.

Failure to follow this warning will cause a serious injury or death.

United States Safe Distances for Power Lines

The distances indicated in the following table are valid for the United States as reported by the American Regulations of the O.S.H.A. (Occupational Safety & Health Administration).

FPL Power Line Voltages	OSHA Minimum Approach Distance* (OSHA 1926.1408 Table A)
0 to 50 kV	10 ft (3 m)
Over 50 kV to 200 kV	15 ft (4.6 m)
Over 200 kV to 350 kV	20 ft (6 m)
Over 350 kV to 500 kV	30 ft (9.1 m)
Over 500 kV to 750 kV	35 ft (10.7 m)

* Minimum distance for travel under power lines must comply with OSHA rules.

Stay clear of overhead power lines and avoid the electrical hazard. Treat all overhead and buried power lines as being energized and not insulated.

Make sure all underground utilities have been marked prior to performing operations.

Underground Hazards

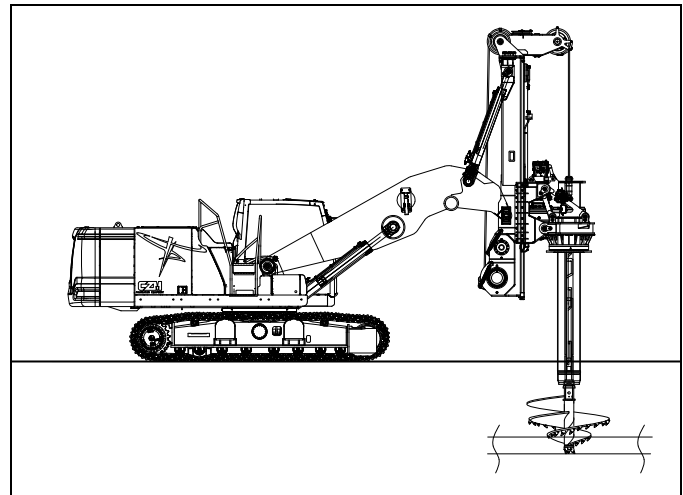

Figure 2-46

0000432

⚠ DANGER

- Keep the machine and attachments a safe distance from buried power sources.
- Stay clear 10 ft (3 m) plus twice the line insulator length.
- Avoid direct contact with high-voltage power lines while operating.
- Identify and avoid direct contact with any underground utilities that may be present at the job site.

Failure to follow this warning will cause a serious injury or death.

Stay clear of buried utilities and avoid the electrical hazard. Treat all overhead and buried power lines as being energized and not insulated.

Make sure all underground utilities have been marked prior to performing operations.

Soil Conditions

WARNING

Performing drilling operations or moving the drilling rig on unstable or uneven terrain could result in a tip over. Make sure to continuously monitor the area around the drilling rig. Failure to follow this warning could result in death or serious injury.

Always examine the area for any hazardous conditions. Some examples are: slopes, overhanging areas, trees, ravines, crags, rough terrain, ditches, ridges, excavations, and so on. If similar conditions exist, proceed with extreme caution.

Often, soft ground conditions exist near newly built walls. The overlay material and the weight of the machine can cause the wall under the machine to collapse.

It is necessary to know the load limitations of the ground, paving, and ramps on which the machine will be operated.

Check the maximum pressure expected under the track in the worst conditions. The ground on which the machine is to be positioned must withstand the maximum load-bearing capacity.

Make sure that the ground on which the machine will rest is solid enough not to compromise stability. If the ground does not give sufficient guarantees of solidity, prepare adequate support plates.

SAFETY

Soil Classification

The Occupational Health & Safety Administration (OSHA) classifies soils into four categories (in decreasing order of strength):

- Stable Rock
- Cohesive Soil Type A
- Cohesive Soil Type B
- Cohesive Soil Type C

Relative strengths of the four soil classifications are measured using the metric, Unconfined Compression Strength, expressed in tons per square foot (tsf). Data on these soils is provided in the following three tables.

**Table 2-1: COHESIVE SOILS
(Unconfined Compressive Strength by Soil Type)**

OSHA Cohesive Soil Type	Description	Unconfined Compressive Strength (tsf)
A	<ul style="list-style-type: none"> • Clay • Silty clay • Sandy clay • Clay loam • Some silty clay loam and sandy clay loam 	≥ 15
B	Granular cohesive soils such as: <ul style="list-style-type: none"> • Angular gravel • Silt • Silt loam • Sandy loam 	0.5 – 1.5
C	Granular soils such as: <ul style="list-style-type: none"> • Gravel • Sand • Loamy sand • Submerged soil • Soil from which water is freely seeping 	< 0.5

**Table 2-2: STABLE ROCK
(Unconfined Compressive Strength by Rock Type)**

Rock Type	Unconfined Compressive Strength (tsf) Minimum	Unconfined Compressive Strength (tsf) Maximum
Schist	84	1729
Sandstone	104	2455
Shale	358	2412
Limestone	369	3894
Granite	505	3383
Gneiss	882	2620

Table 2-3: CLAYS (Unconfined Compressive Strength by Consistency)

OSHA	Unconfined Compressive Strength (tsf)
Very Soft	0 – 0.25
Soft	0.25 – 0.50
Medium	0.5 – 1.0
Stiff	1 – 2
Very Stiff	2 – 4
Hard	>4

Soil Subsidence

In case of subsidence of the soil under a track of the machine, follow this procedure:

1. Immediately stop the activity.
2. Evacuate the surrounding area.
3. Proceed to consolidate the soil to restore the horizontal support surface and the vertical work surface.

Slopes and Ditches

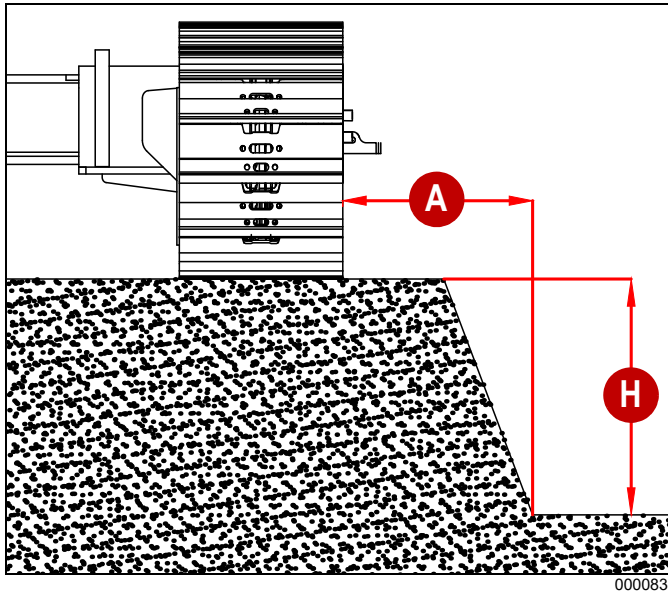

Figure 2-47: Slopes and Ditches

In presence of slopes or ditches, keep the tracks at a safe distance from the edge. The safety distance (A) from the foot of the embankment must be adequate for the height (H) of the embankment.

If the ground is good (loose ground, well compacted, sand, gravel, or coherent solid ground) the distance (A) must be equal to the height (H) of the slope (A:H=1:1). In case of doubt, the distance (A) must be double the height (H) of the slope (A:H=2:1).

Operation and Use of the Drilling Rig

⚠ WARNING

- Other than the operator in the cab, no other people must be on the machine during operation.
- Accessing the walkable areas of the machine is only allowed to carry out assembly and maintenance operations on the machine, while respecting all the safety requirements.

Failure to follow these warnings may result in death or serious injury.

Access to the Drilling Rig

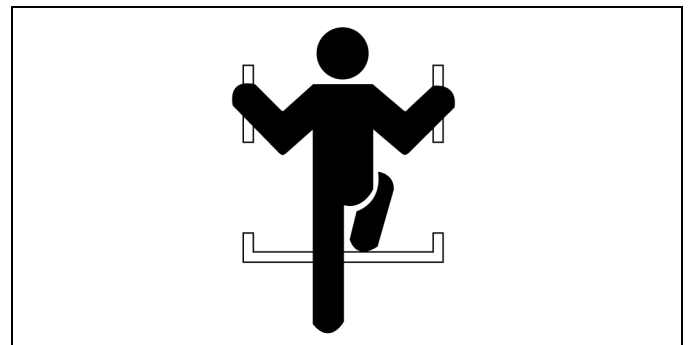

Figure 2-48: Mount and Dismount

Mounting or dismounting the base machine presents hazards. Observe the following:

- Mount and dismount only with the provided grab handles and steps by facing the base machine.
- Always maintain three-point contact (such as both feet and one hand, or one foot and both hands) using the grab handle and steps for proper safety and support.
- Wear personal protective equipment (PPE) as required. Wear safety shoes with slip-resistant soles.
- Clean the sole of the shoes by removing mud or grease before getting on the machine.
- Do not walk on any surface of the drilling rig if the slip-resistant material is missing or excessively worn.
- Do not step on surfaces that are not approved for walking or working on the machine.
- Always keep grab handles, steps, and walkway areas free of slipping hazards and debris. Repair or replace any damaged items immediately.
- Do not mount and dismount carrying tools or other items.

SAFETY

- Do not use the controls, hoses, or other parts of the machine as supports, these components do not offer stable support. In addition, the involuntary movement of a command can cause accidental movement of the machine or equipment.
- Do not jump to mount or dismount the machine.
- Do not mount or dismount the machine while it is moving. Mount or dismount the machine only when it is completely stopped.

Workplace

⚠ WARNING

- Any modifications to the inside of the operator cab should not project into the operator space.
- Additional accessories such as radio, fire extinguisher, and other equipment must be installed so that the defined operator space is maintained.
- Any item that is brought into the cab should not project into the defined operator space.
- A lunch box or other loose items must be secured. Objects must not pose an impact hazard in rough terrain or in the event of a rollover.
- With the machine running, the operator must not leave the cab.
- In addition to the operator in the cab, no other people must be on the machine during operation.

Failure to follow these warnings may result in death or serious injury.

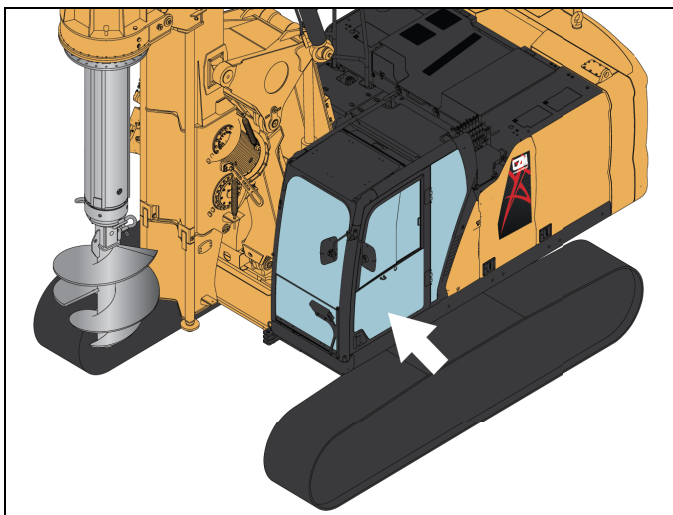

0000832

Figure 2-49: Workplace – Cab

The established workplace is the operator's cab, which is located in the position shown in the above figure.

Keep the cabin clean, both inside and outside. Do not place newspapers or other objects on the controls.

Personal items or tools must not affect the use of the controls.

Keep access to the cabin free of obstacles.

Keep the cab windows clean, not fogged and free from ice.

Emergency Exit



0000401

Figure 2-50: Emergency Exit

The cab is equipped with an emergency exit.

Alternate Exit

Rear Window with Ring Seal (If Equipped)*

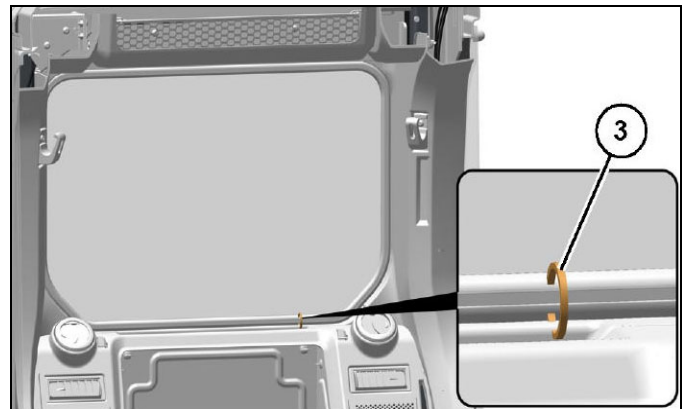

g06187008

Figure 2-51: Alternate Exit-Rear Window with Ring Seal

To remove the rear window:

1. Pull ring (3) and completely remove the window seal.
2. Push out the glass.
3. Climb through the rear window opening to exit cab.

Rear Window with Lever (If Equipped)*

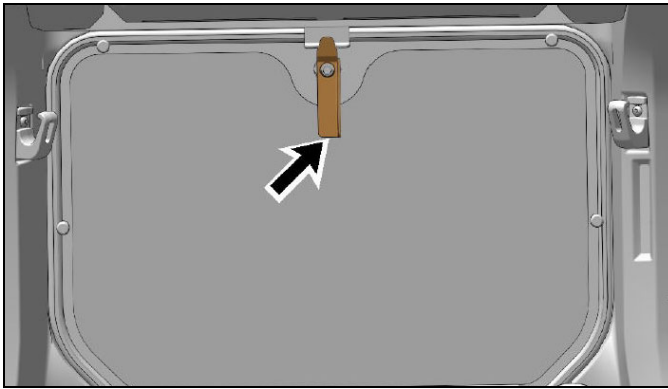

g06213470

Figure 2-52: Alternate Exit-Rear Window with Lever

To remove the rear window:

1. Rotate the handle from its latched position.
2. Push out the glass.
3. Climb through the rear window opening to exit cab.

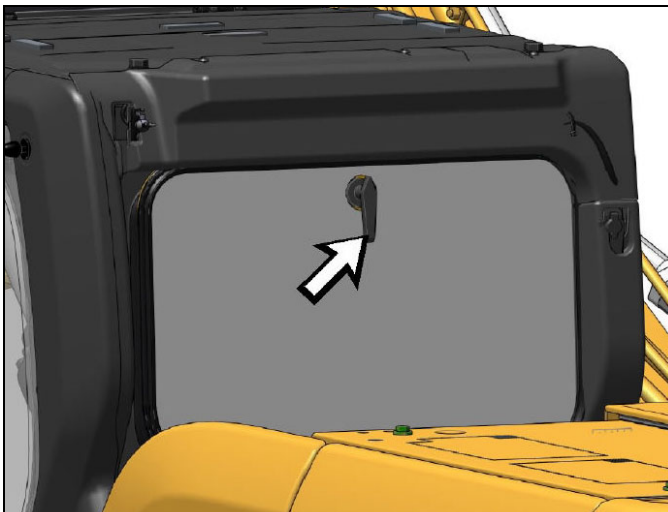

g06213471

Figure 2-53: Alternate Exit-Rear Window Outside Handle

The window is also equipped with an outside handle. If the operator is unable, outside personnel can rotate the outside handle and pull the window out.

Guards

⚠ WARNING

- During drilling, objects could strike the front or top of the cab.
- The front and top guards must be installed on the cab.
- A daily inspection of the guards is required in order to check for structures that are bent, cracked, or loose. Never operate a machine with a damaged structure.

Failure to follow this warning could result in death or serious injury.

Observe the following guidelines:

- Keep all guards and safety devices in place.
- Restrict the area where the machine is being operated or maintenance is being performed.
- Keep all unnecessary personnel out of the work area.

SAFETY

Before Starting Engine*

WARNING

Diesel engine exhaust contains products of combustion which can be harmful to your health. Always run the engine in a well-ventilated area. If you are in an enclosed area, vent the exhaust to the outside.

If a warning tag (lockout/tagout tag) is attached to the engine start switch or the controls, do not start the engine. Also, do not move any controls.

Failure to follow these warnings may result in death or serious injury.

SMCS Code: 1000; 7000

Start the engine only from the operator compartment. Never short across the starter terminals or across the batteries. Shorting could damage the electrical system by bypassing the engine neutral start system.

Inspect the condition of the seat belt and of the mounting hardware. Replace any parts that are worn or damaged. Regardless of appearance, replace the seat belt after 3 years of use. Do not use a seat belt extension on a retractable seat belt.

Adjust the seat so that full pedal travel can be achieved with the operator's back against the back of the seat.

Make sure that the machine is equipped with a lighting system that is adequate for the job conditions. Make sure that all machine lights are working properly.

Before you start the engine and before you move the machine, make sure that no one is underneath the machine, around the machine, or on the machine. Make sure that the area is free of personnel.

Engine Starting*

SMCS Code: 1000; 7000

If a warning tag is attached to the engine start switch or to the controls, do not start the engine. Also, do not move any controls.

Make sure that you are seated before you start the engine.

Move all hydraulic controls to the HOLD position before you start the engine. Move the hydraulic lockout control to the LOCKED position. For further details on this procedure, refer to "Hydraulic Lockout Control*" on page 6-7.

Diesel engine exhaust contains products of combustion which can be harmful to your health. Always run the engine in a well-ventilated area. If you are in an enclosed area, vent the exhaust to the outside.

Briefly sound the horn before you start the engine.

Before Operation (Engine Started)*

SMCS Code: 7000

NOTICE

Do not operate the engine without engine coolant.

If the engine coolant expansion tank is empty, there may be an engine coolant leak. Inspect for engine coolant leaks and repair if found. If a leak is not found, check for an internal leak.

Failure to follow this notice could result in damage to the engine or cause it to operate improperly.

Warm up the engine and the hydraulic oil before operating the machine.

Pay attention in the presence of dust, smoke, or fog. Poor visibility can cause dangerous use of the machine with possible serious damage to people. In dark conditions, carefully check the area before operating the machine.

If the hydraulic devices are irregular in their stroke or abnormal in their response, have the machine checked for the presence of air in the system. The presence of air in these systems could cause incorrect movements with the resulting possibility of accidents.

Make sure that the engine speed is adequate for the work you intend to perform. If the engine tends to slow down and stop under load or at idle, stop the machine and make any necessary repairs.

Do not operate when one or more alarm lights are active. Stop the machine and solve the problems.

If a removable counterweight is equipped, do not use the machine if the counterweight has been disassembled. Do not add additional counterweights if they are not expressly provided for.

Never leave the machine with the engine running.

Before moving the machine, check the position of the undercarriage. The normal travel position is with the idler wheels to the front under the cab and the drive sprockets to the rear. When the undercarriage is in the reversed position, the directional controls must be operated in opposite directions.

Machine Safety

Danger Zone

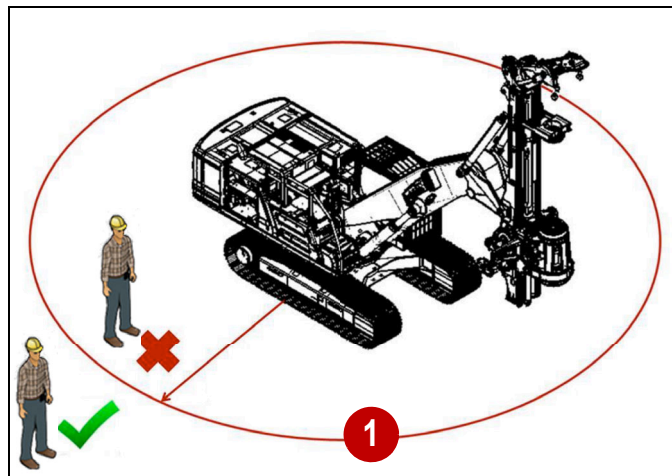

Figure 2-54

0000392

A danger zone of 65 ft (20 m) (1) should be restricted when the drilling rig is in operation. The operator should prevent personnel from entering this area.

Stop drilling rig operations, if required, until the danger zone is clear for operations to resume.

If the operator cannot see the operation equipment or other hazards in the danger zone, a signal person should be utilized. A signal person should also be used if surrounding noise prevents normal vocal communication.

Signal Person and Hand Signals

⚠️ WARNING

Hand signals must be mutually agreed upon by the operator and the signal person before operations begin. Proper communication is essential to job site safety. Failure to follow this warning could result in death or serious injury.

Responsibilities of the signal person include:

- Using hand signals that are easily identified and understood by the operator to provide effective communication.
- Standing in a safe location while observing potential hazards within the danger zone.
- Different countries may have different hand signals. Follow the local hand signal standards.

SAFETY

Machine Parking

⚠️WARNING

Always park the drilling rig on a suitable area. Make sure that the kelly bar is touching the ground. Switch off the engine and prevent any unauthorized access to the cab, taking all necessary safety precautions. Failure to follow these warnings may result in death or serious injury.

Wind Speed

⚠️WARNING

The operator must be aware of weather forecasts and actual wind speed conditions at the job site. To avoid a tip over, do not exceed the maximum allowable wind speed limit. Failure to follow this warning could result in death or serious injury.

The drilling rig can be operated up to wind speeds of 20 m/s (65 ft/s) (45 mph) maximum, measured at ground level. Work must be suspended if this limit is exceeded.

The drilling rig must not be left with the mast in the vertical position if the wind speed exceeds 28 m/s (91 ft/s) (63 mph), which could result in a tip over.

Authorized Use of This Drilling Rig

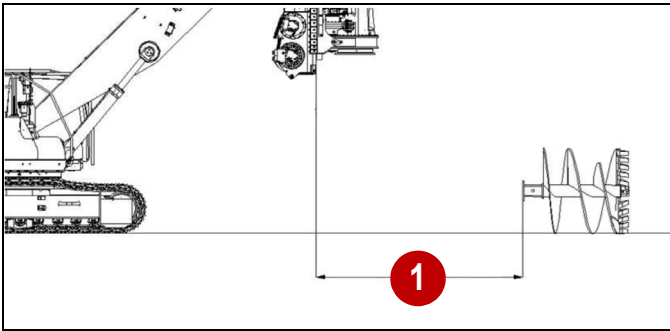

Figure 2-55

0000393

The drilling rig is used to bore holes to create foundation piles. The compact and reliable design is equipped with an auxiliary winch, which should only be used for moving the augers, pipes, pile fittings, and other authorized drilling accessories.

Make sure that any accessory lifted is aligned with the head masthead mast and is at a horizontal distance less than 10 ft (3 m) (1) from the mast.

Unauthorized Use of This Drilling Rig

⚠️WARNING

The drilling rig is intended to be used only as a drilling rig. It is not a crane and should not perform crane operations. The drilling rig should only be used to lift authorized drilling rig components to avoid a tip over. Failure to follow this warning could result in death or serious injury.

The unauthorized uses include, but are not limited to, the following:

- Transporting people on the base machine or in the cab.
- Lifting or transporting loads or equipment.

Unauthorized Modifications

⚠️WARNING

Do not allow unauthorized persons to be on the working area of the drilling rig when it is in operation. Stop working and make sure that the people in the danger zone area move away, if required. Failure to follow this warning may result in death or serious injury.

Do not perform any unauthorized drilling rig modifications.

Do not add weight, such as unauthorized attachments to the drilling rig, which may exceed the gross weight.

Fire Safety

Fuel, engine oil, and some engine coolants are flammable. Observe the following:

- Check the drilling rig daily for debris buildup.
- Keep open flames, sparks, and burning embers away from the drilling rig.
- Shut down the engine and do not smoke when refueling or servicing the drilling rig.
- Add hydraulic and engine oil, fuel, and engine coolant in a well-ventilated area.
- Clean up any spilled fluids immediately.

Know where the fire extinguisher is located on the machine. For an additional safety measure, keep a fire extinguisher near the operator.

Locate secondary exits and know how to use these exits before operating the machine.

Transportation and Lifting Safety

Transportation

⚠️ WARNING

- Select a firm, level location to prevent the drilling rig from tipping over.
- Make sure the trailer is properly chocked to prevent any movement.
- Use an access ramp with enough length, strength, and width to properly support the drilling rig. The ramp grade should not exceed 15 degrees.
- Drive slowly at the junction of the ramp and the trailer. A sudden shift may change its center of gravity and could cause a tip over.
- Designate and use a signal person to alert the operator to any potential hazards.

Failure to follow these warnings could result in death or serious injury.

All applicable laws and regulations must be observed:

- When transporting the drilling rig and base machine on a trailer, confirm the length, width, height, and weight capacity of the trailer before loading.
- Verify road conditions in advance for any restrictions such as dimension restrictions, weight restrictions, or traffic regulations that may prevent transporting the drilling rig and base machine.

When transporting and/or handling the drilling rig and base machine, always do so in compliance with the drilling rig and base machine decals and manual procedures. Personnel that are loading, unloading, and handling the drilling rig and base machine must be skilled and experienced. When moving the drilling rig and base machine, the operator is responsible for the safety of job site personnel.

Make sure the drilling rig, base machine, and its components are properly secured, and do not exceed the overall dimension limits for transportation.

Lifting the Drilling Rig/Base Machine

⚠️ WARNING

- Make sure that all lifting devices are in safe operating condition and have a sufficient capacity rating to safely support the intended load.
- Never lift the drilling rig with a person inside the cab.
- Never allow a person to stand close to, or under, a lifted drilling rig.
- To prevent unexpected movement of the drilling rig, make sure the engine is shut down and the battery disconnect switch is set to the OFF position before beginning the lifting procedure.
- Keep the drilling rig level during lifting.
- Always lift with the longitudinal centerlines of the upper structure and undercarriage parallel to each other to keep the drilling rig balanced.

Failure to follow these warnings could result in death or serious injury.

Personnel must be well trained and experienced before performing drilling operations.

Job Site Safety

⚠ WARNING

- **Use caution when drilling close to the drilling rig. Drilling close to the rig may affect ground stability, which could result in a tip over.**
- **Make sure the work zone is properly marked with safety barriers and appropriate lighting when working near a roadway. Avoid interfering with road traffic and pedestrians.**
- **Follow all applicable laws and regulations for job site safety requirements.**

Failure to follow these warnings could result in death or serious injury.

The incidence of drilling rig accidents depends on numerous factors that cannot always be prevented or controlled. Accidents may occur based on unpredictable environmental factors while others occur from specific operator actions. In addition to being authorized and adequately documented, it is sometimes necessary for operators to simulate certain maneuvers the first time they use the drilling rig in order to become proficient.

Use the drilling rig only for the authorized purposes as intended. Before using the drilling rig, make sure that the safety devices are properly installed and functioning properly.

Operators must also apply all applicable safety standards for safe operation. The operator must also read and understand all manual instructions for the drilling rig controls and operations.

Before starting operations, the operator must be trained, skilled, and experienced for all operations involved.

After reading this manual and before the first time the drilling rig is used, it is necessary that the operator is supervised by an expert in the type of operation that the drilling rig will perform.

Do not operate the drilling rig if the safety devices are not properly installed and perfectly efficient. Removing safety devices pose a severe risk to personal health and safety.

Improper use of the drilling rig can pose a severe risk to personal health and safety and cause economic damage. This may void the warranty, and CZM will not assume any liability for the improper use of the drilling rig.

Inclination Limits / Mast Positioning

⚠ WARNING

When moving the machine, position the mast according to the images below for each specific situation. Always keep the rotary down and the kelly bar close to the ground. Keep the boom forward to allow the mast shoe to be close to the ground. Never walk the machine on uneven or unstable ground. Never exceed the inclination limits shown below without an approved and signed engineering procedure. Failure to follow the warning may result in death or serious injury.

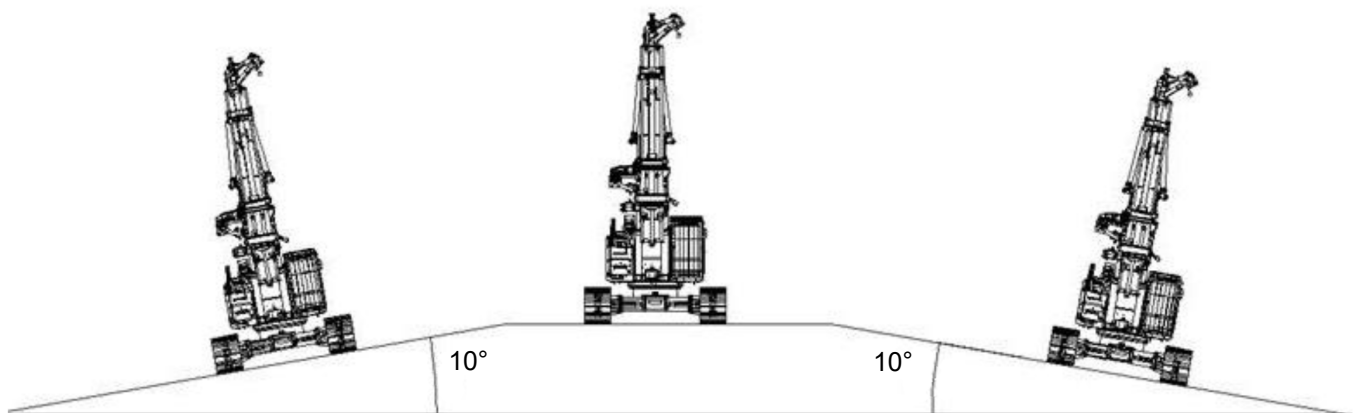

Figure 2-56

0000394

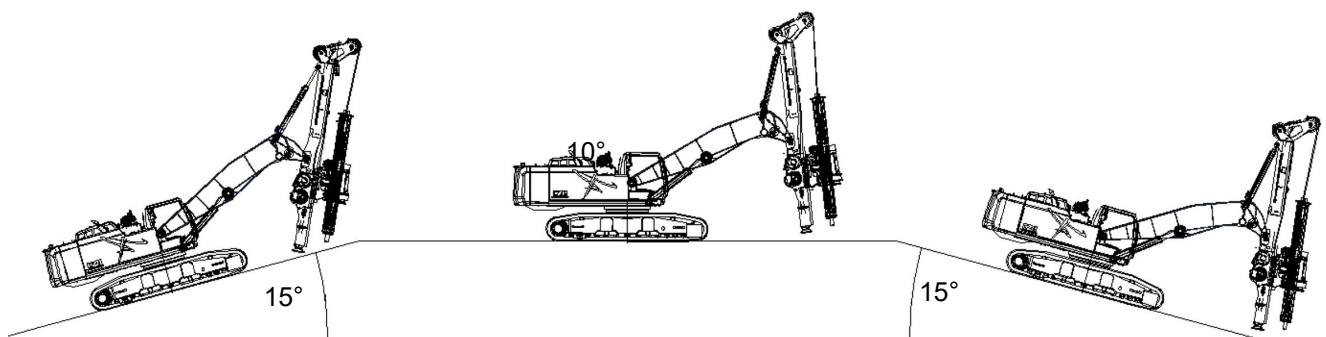

Figure 2-57

0000395

SAFETY

Drilling Rig Stability and Ground Pressure

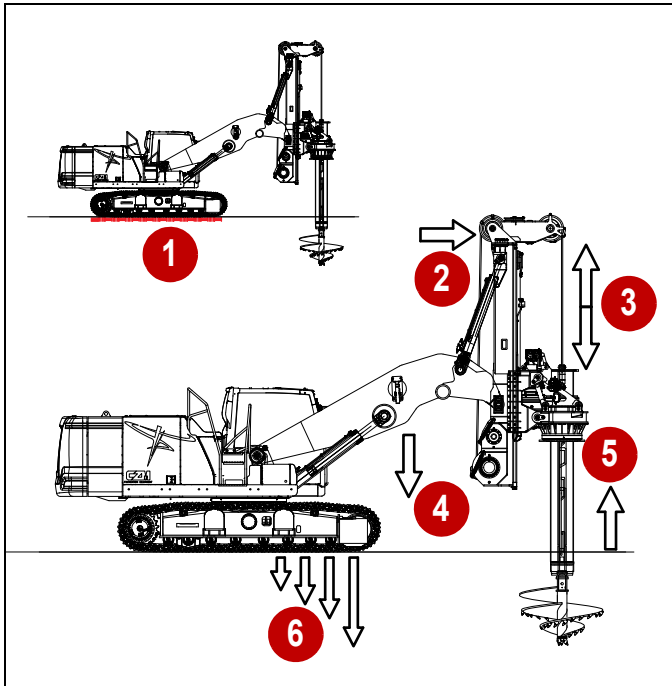

Figure 2-58

0000442

⚠️ WARNING

- The crawlers must be fully extended before raising the mast or swinging the drilling rig for proper stability. Do not swing the machine if the crawlers are not fully extended.
- Do not swing the machine with the mast lowered if the crawlers are not fully extended.
- Do not swing the machine with the counterweights removed which could lead to a tip-over.
- Make sure to use a spotter when raising or lowering the mast to ensure job-site safety.
- Make sure to follow danger zone safety precautions.
- Make sure there is the proper safety radius maintained when raising or lowering the mast, and make sure no personnel are in the path of mast during operations.
- Performing any operation without the crawlers fully extended reduces the load-bearing capacity of the drilling rig during operation, which could lead to a tip over.

Failure to follow these warnings could result in death or serious injury.

Stability is a concern for a drilling rig as it has a long mast to be able to drill the required depths. Tipping over is a hazard that can occur by the operator exceeding the degrees of slopes that the machine can safely operate on while traveling, swinging, lifting loads, drilling, and so on. Tip over can also occur by failing to set-up the machine correctly, such as not expanding the tracks, not installing the counterweight, not following the limits of weight for the auxiliary winch, tooling, and so on. A major concern is when machine induced ground pressure (6) exceeds the resistance of the soil.

The ground pressure is a factor of the weight of the machine (4) and how it is balanced with the induced loads such as the main winch pulling force (5), crowd cylinder pushing/pulling force (3), wind forces (2), and auxiliary winch pulling force.

Exceeding the ground resistance can cause the ground to fail and is the primary reason of machine tip over.

Always follow the guidelines of stability and ground pressure for the operation being proceeded, refer to Chapter 3 Stability.

Whenever necessary, a work platform (1) should be required under the machine to prevent tipping over.

Unstable or Uneven Terrain

⚠️ WARNING

Make sure to continuously monitor the area around the drilling rig when drilling operations are performed to avoid a tip over. Failure to follow this warning could result in death or serious injury.

Performing drilling operations on unstable or uneven terrain could result in a tip over when soil and ground material is removed around the drilling rig. This decreases the ground pressure supporting the drilling rig. Tip over can result unexpectedly from a change in ground pressure around the drilling rig during normal operations.

Use the appropriate sized support mats, as required, to maintain stability of the drilling rig.

Traveling Up Hill

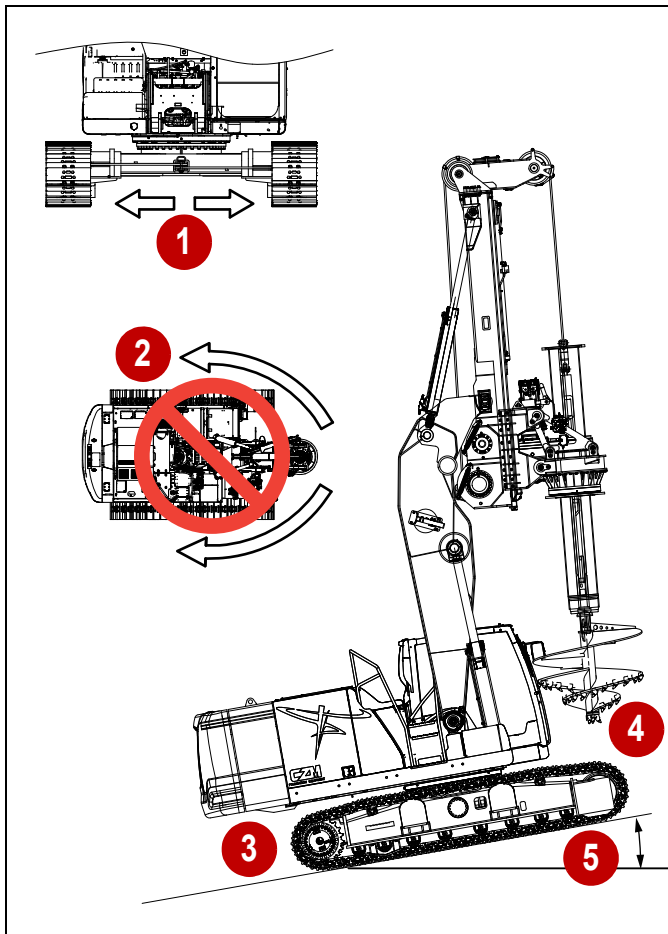

Figure 2-59

0000443

NOTE: See “Drilling Stability – Forward Facing” on page 3-4 for the stability calculations. The stability calculations are based on acceptable ground conditions as described in “Soil Conditions” on page 2-31.

NOTE:

When traveling up a slope, take the following steps to maintain stability of the machine:

- Undercarriage tracks must be expanded (1).
- Do not swing the machine (2).
- Undercarriage should be facing forward (3).
- Keep rotary, kelly bar, and auger close to the ground (4).
- Do not exceed a 15 degree slope (5).

Traveling Down Hill

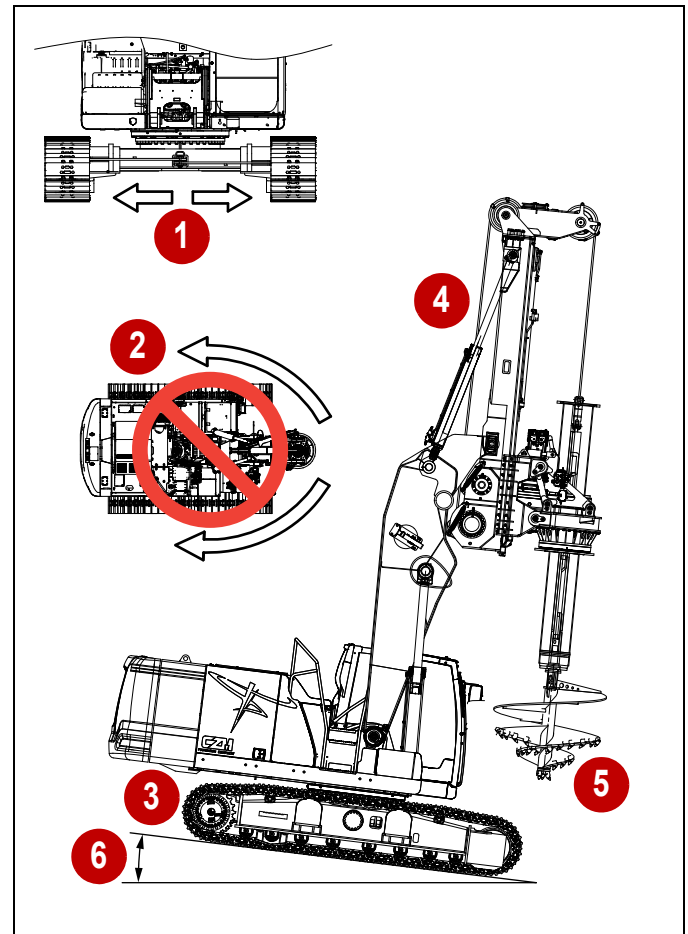

Figure 2-60

0000444

NOTE: See “Drilling Stability – Forward Facing” on page 3-4 for the stability calculations. The stability calculations are based on acceptable ground conditions as described in “Soil Conditions” on page 2-31.

When traveling down a slope, take the following steps to maintain stability of the machine:

- Undercarriage must be expanded (1).
- Do not swing the machine (2).
- Undercarriage should be facing forward (3).
- Adjust the mast back so it is vertical or up to 3 degrees back (4).
- Keep rotary, kelly bar, and auger close to the ground (5).
- Do not exceed a 15 degree slope (6).

SAFETY

Traversing Slopes Safely

NOTICE

When facing forward with the undercarriage extended, the LR95 may not travel across slopes exceeding 15 degrees.

When facing sideways with the undercarriage extended, the LR95 may not travel across slopes exceeding 10 degrees.

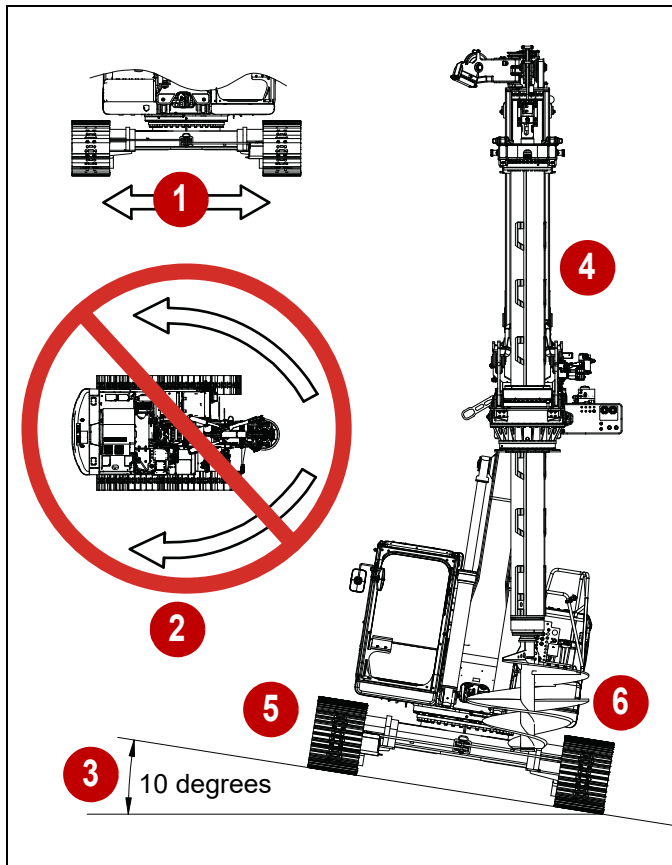

Figure 2-61

0000876

When traveling across a slope, take the following steps to maintain stability of the machine:

- Undercarriage tracks must be expanded (1).
- Do not swing the machine (2).
- Do not travel across gradients exceeding 5 degrees (3).
- Align the mast to maintain vertical position (4).
- Undercarriage should be facing forward (5).
- The rotary, kelly bar, and auger must be kept close to the ground (6).

Swing Operation Safety

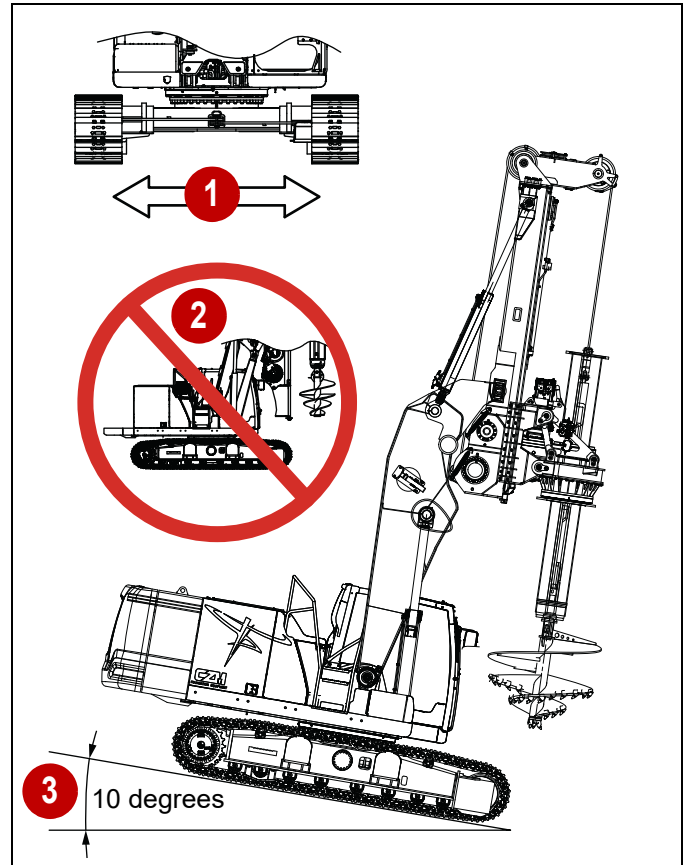

Figure 2-62

0000877

⚠ WARNING

- Swing operation must be performed with extreme caution and care.
- Verify that the area around the drilling rig is clear when performing swing operations.
- Fast or sudden movements could result in loss of control and a tip over.
- Make sure the tracks are fully open to maintain base machine stability before performing swing operations.

Failure to follow these warnings could result in death or serious injury.

- Do not swing the machine with the undercarriage tracks retracted (1).
- Do not swing the machine without counterweights installed (2).
- Do not swing on a slope greater than 5 degrees (3).

Respect the working radius of the machine. Refer to Chapter 3, “Stability”.

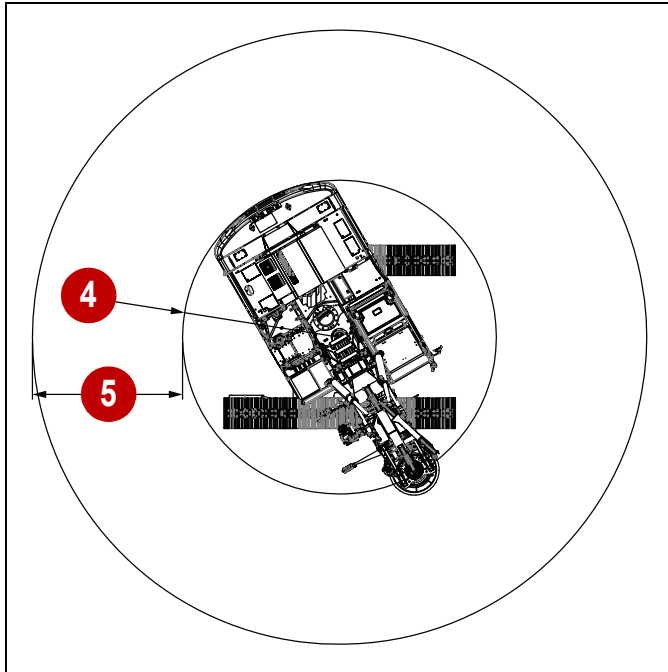

Figure 2-63

0000247

- The operator does not have 360 degree visibility. Use extra caution when swinging the machine.
- Make sure there are not any personal or obstacles inside the machine swing radius (4).

Personnel should be at least 10 ft (3 m) (5) outside of the machine swing radius.

Mast Raising/Lowering Safety

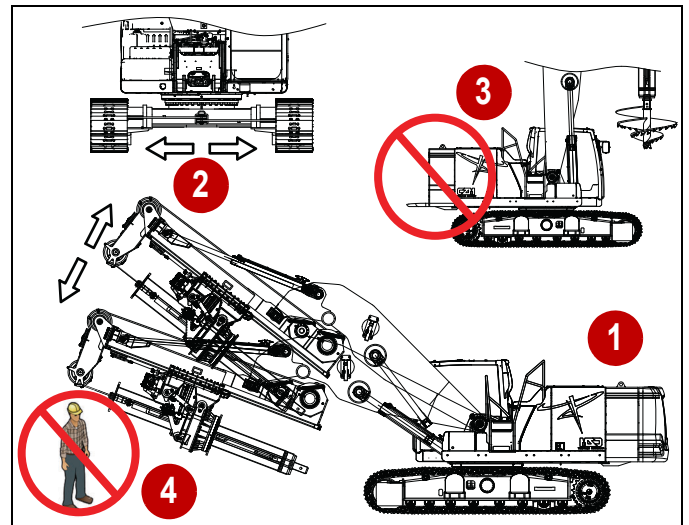

Figure 2-64

0000448

⚠ WARNING

- Do not raise or lower the mast with the undercarriage in the closed (unextended) position.
- Do not raise the mast without counterweights installed.
- Do not remove the counterweights with the mast raised above 30 degrees.

Failure to follow these warnings could result in death or serious injury.

Before raising or lowering the mast, position the rotary and kelly bar to the middle of the mast (1). Verify that the tracks are extended (2) and counterweights are installed (3). All personnel must be outside the safety perimeter (4).

SAFETY

If the operator does not have a 360 degree field of view, a spotter is required when moving the mast or machine.

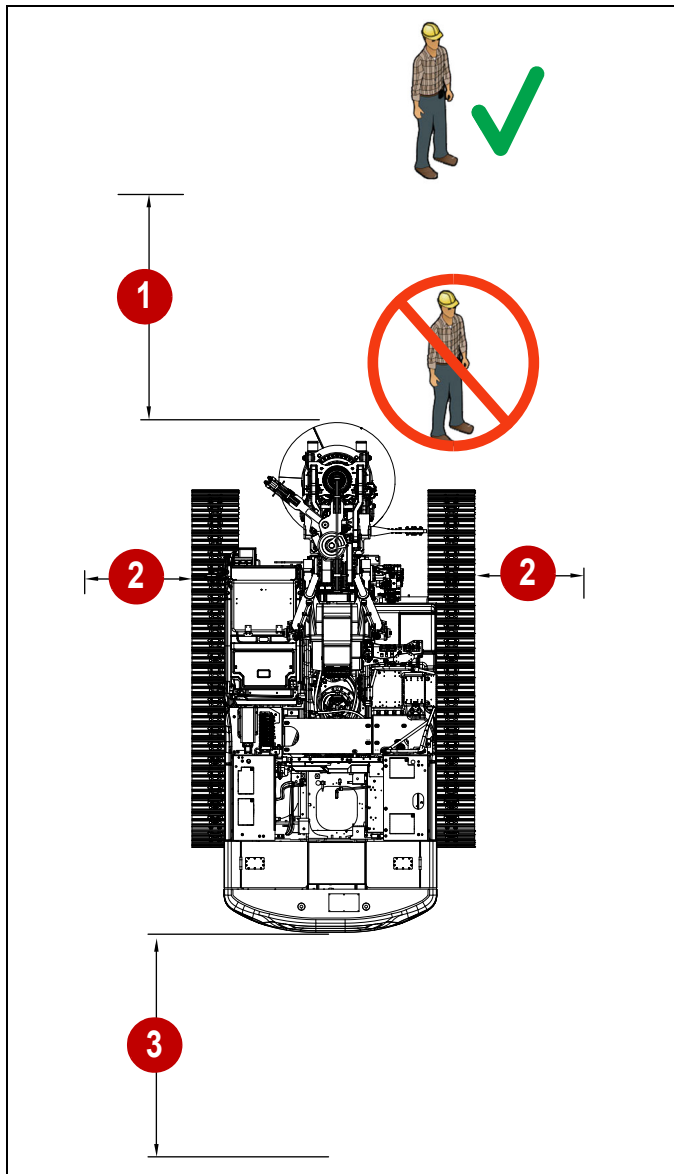

Figure 2-65

0000888

Make sure that there are no personnel or obstacles in the machine safety perimeter.

These safety distances should also be maintained when moving the machine or during loading onto a vehicle for transport:

- 10 ft (3 m) in front of machine (1).
- 5 ft (1.5 m) to sides of machine (2).
- 10 ft (3 m) in back of machine (3).

Auxiliary Winch Safety

⚠ WARNING

- Do not lift loads heavier than shown on the stability chart. Refer to Chapter 3, “Stability”.
- Do not swing the machine more than specified on the stability chart. Refer to Chapter 3, “Stability”.
- Do not travel with a suspended load.
- Do not use the auxiliary winch to lift personnel.
- Do not drag loads with the auxiliary winch.
- The maximum angle for the auxiliary winch line is 5 degrees.
- Do not lift loads off the ground more than 1 ft (0.3 m).

Failure to follow these warnings could result in death or serious injury.

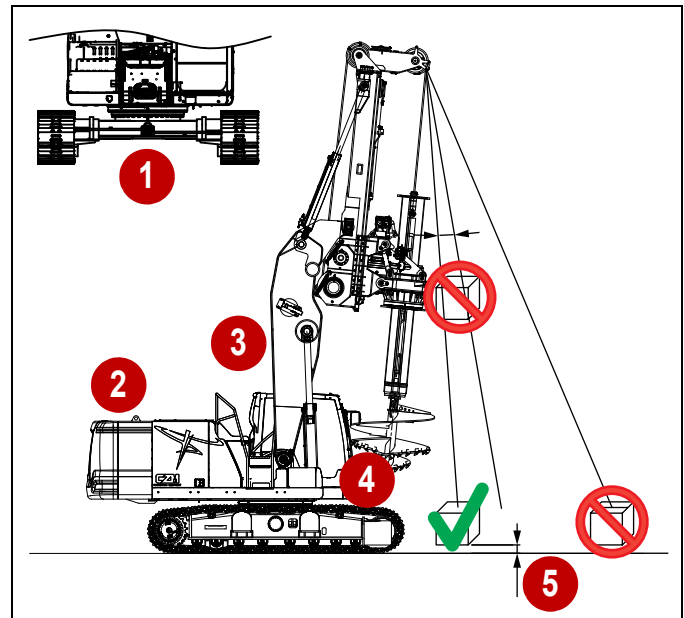

Figure 2-66

0000878

The drilling rig cannot be used as a crane. The maximum slope on which the auxiliary winch can be used is 3 degrees.

Before using the auxiliary winch:

- The undercarriage must be extended (1).
- Counterweights must be installed (2).
- The boom arm should be positioned back (3).

The rotary, kelly bar, and auger must be positioned close to the ground (4). The load should not be lifted more than 1 ft (0.3 m) off the ground (5).

Open Hole Safety

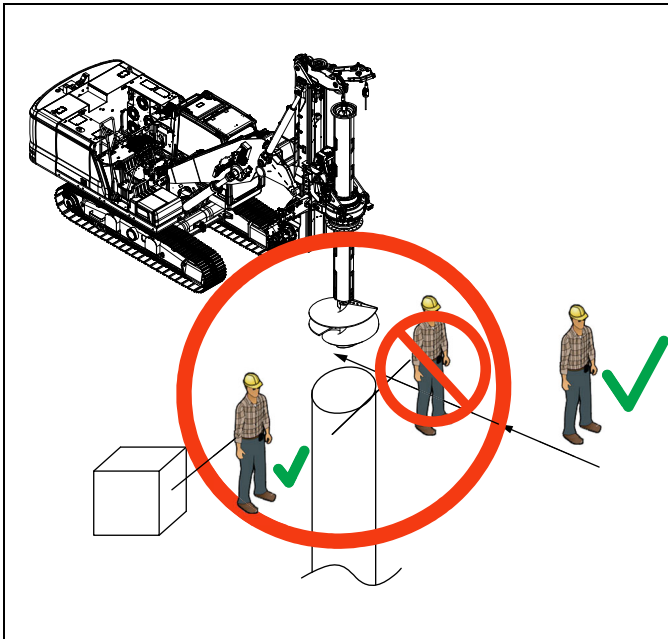

Figure 2-67

0000447

⚠️ WARNING

- Personnel should maintain a minimum of 10 ft (3 m) from open holes unless a safety harness and appropriate fall protection are used. The safety harness must be attached to an authorized structure to protect the worker.
- Make sure all open holes are properly marked and secured at the job site.

Failure to follow these warnings could result in death or serious injury.

Open holes are a falling hazard. The soil could cave in and considerably increase the diameter of the hole. A safety distance of 10 ft (3 m) (1) should be marked or a safety barrier be installed outside of the machine swing radius. If personnel are to get close to the hole, they should be wearing a safety harness attached to an approved structure. Always use the proper technique to stabilize the hole.

Maintain a minimum of 10 ft (3 m) around open holes to ensure personnel safety while operating in the restricted danger zone. An appropriate safety harness and fall protection should be used, if required, to work within the safe zone for drilling operations. See “Danger Zone” on page 2-37 for additional information.

Spin-Off Safety Zone

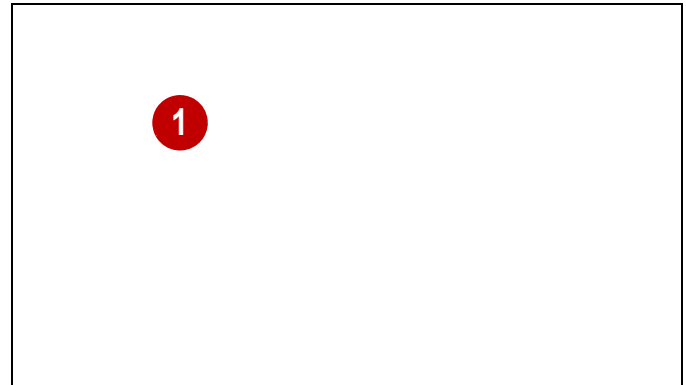

Figure 2-68

0000245

⚠️ CAUTION

- Spin-off operations can propel debris at high speed.
- Do not allow personnel in the danger zone during drilling operations and when spin-off is occurring.

Failure to follow these cautions could result in injury.

During the spin-off operation, the auger rotates at a very high speed to discharge the dirt, rocks, and other debris, which could be thrown away from the auger at high velocity.

Before spinning off the auger, lower it to the ground to reduce the distance objects may be thrown and be sure that there is no one inside a 10 ft (3 m) (1) safety radius to the tool.

SAFETY

Kelly Bar and Auger Safety

⚠ WARNING

- No personnel are allowed under a suspended load.
- Do not work under a raised rotary/kelly bar.
- Do not place hands between extended kelly bar sections.
- Do not place fingers in auger/kelly bar mounting holes to check alignment.

Failure to follow these warnings could result in death or serious injury.

Installation of a kelly bar into the rotary or auger is a dangerous procedure.

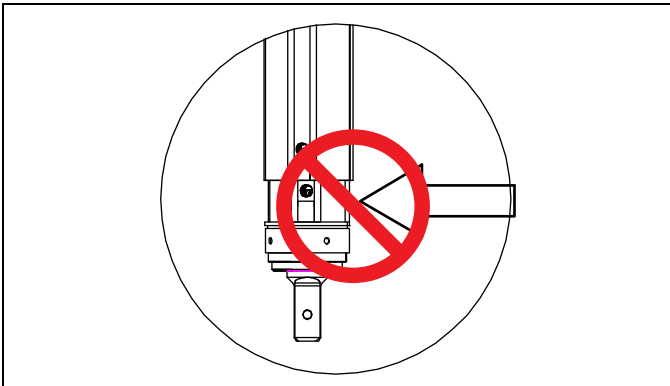

Figure 2-69

0000309

Kelly bars have telescoping sections that may not be fully collapsed. Do not place hands close to kelly bar sections as they may collapse suddenly.

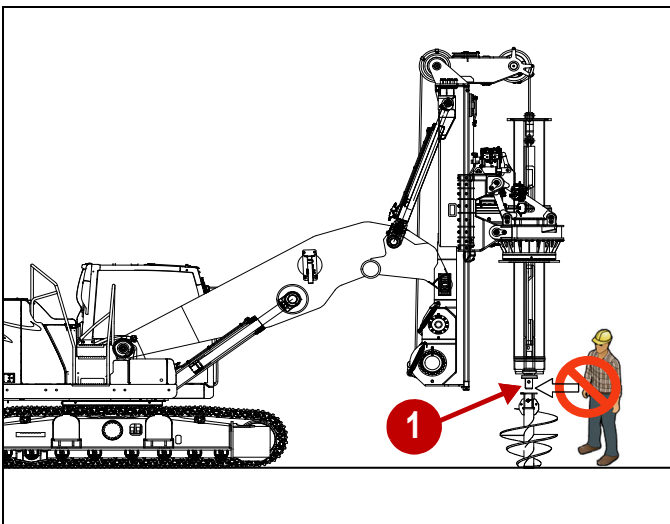

Figure 2-70

0000450

If needed, use a pry bar to align the auger mounting hole with the kelly bar. Do not try to align holes with your hands (1).

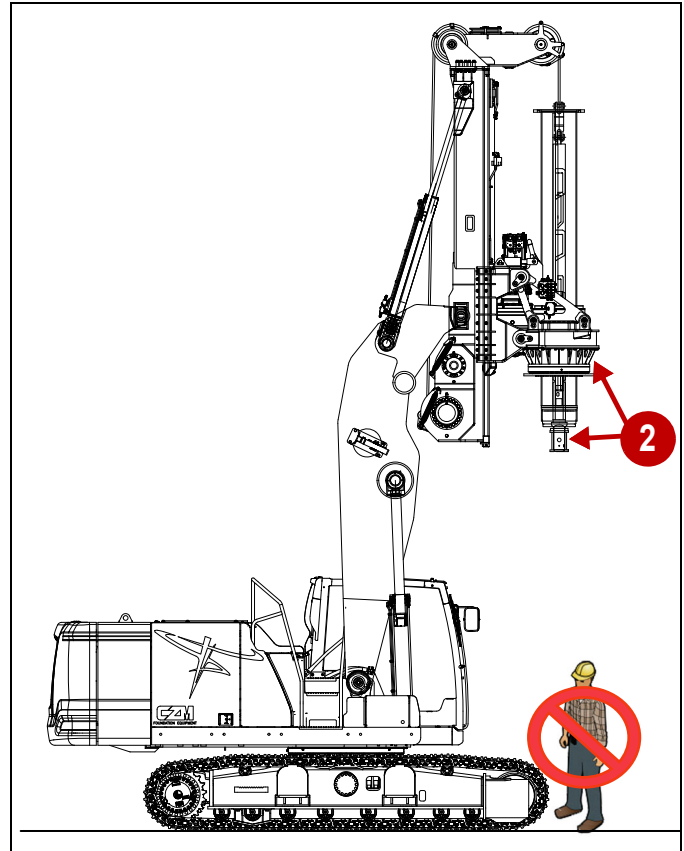

Figure 2-71

0000449

Do not get under a suspended rotary and kelly bar. (2)

During installation of the kelly bar into the rotary, lower the rotary to the ground and check the kelly bar alignment at the top of the rotary. Do not work underneath a raised rotary/kelly bar.

Barge Safety

WARNING

- **Make sure that the drilling rig to be utilized will safely perform all of the intended drilling operations and will not fall off of the barge due to an inadequate rating of the barge.**
- **Follow all applicable laws and regulations where the drilling operations are performed.**

Failure to follow this warning could result in death or serious injury.

Secure the drilling rig in place with appropriately rated chains when operating on a barge.

Make sure the barge is capable of performing the intended drilling operations before drilling operations begin. The barge must be capable of safe drilling operations from the loads encountered during drilling, main winch, and service winch operations.

Wear appropriate personal protective equipment (PPE) and wear an approved personal flotation device (PFD) at all times when operating on a barge.

Traffic Operation Safety

Use caution when working close to roads or vehicle traffic. Make sure the work zone is properly marked with appropriate barriers and lighting to ensure job site safety.

Wear an approved reflective safety vest and additional personal protective equipment (PPE) as required.

Follow all applicable laws and regulations for job site safety requirements when working close to roads or vehicle traffic.

Environmental Precautions

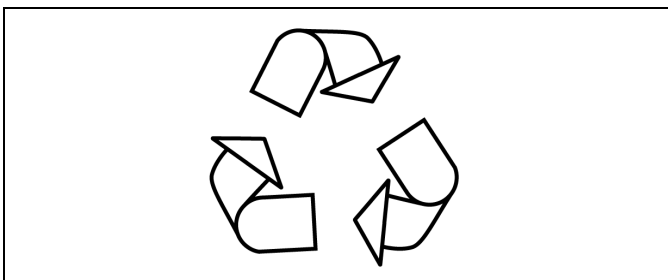

0000106

Figure 2-72

NOTICE

Dispose of used hydraulic and engine oil, filters, fluids, engine coolant, and other hazardous waste in accordance with all applicable environmental regulations.

Oils and coolants can contaminate and pollute soil, groundwater, streams, and rivers. Recycle used oils, coolants, and filters to conserve natural resources and protect the environment.

Temperature Indications

The diesel engine and hydraulic oil temperatures must be monitored during operations. If temperatures exceed their normal operating limits, a warning light will indicate that the engine or hydraulic oil has overheated. If overheating occurs, reference the base machine operator manual.

Monitor the engine coolant temperature during operations to prevent the engine from overheating.

NOTICE

Do not operate the engine without engine coolant. If the engine coolant expansion tank is empty, there may be an engine coolant leak. Inspect for engine coolant leaks and repair if found. If a leak is not found, check for an internal leak. Failure to follow this notice could result in damage to the engine or cause it to operate improperly.

SAFETY

Maintenance Safety

⚠ WARNING

Before performing maintenance, read and understand the general safety warnings and specific safety messages in each maintenance procedure. Failure to follow this warning could result in death or serious injury.

CZM cannot foresee every circumstance that may involve a hazard during operation or maintenance. Therefore, the hazard alerts in this manual and on the drilling rig may not include all possible safety precautions.

⚠ WARNING

In case of any hydraulic leak, stop the machine immediately to prevent the risk of causing injury to personnel, equipment malfunction, and environmental damage.

The LR95 uses high-pressure hydraulically powered components. High-pressure hydraulic hoses can be dangerous. Avoid working near pressurized hydraulic hoses.

Check the machine constantly for damaged hoses and connections and replace them immediately. See “Maintenance Plan” on page 10-7.

Damaged hoses may rupture unexpectedly and hot oil may injure personnel. Leaks through small holes can inject oil at high-pressure, causing serious injuries. In case of injury resulting from hydraulic oil, seek medical attention immediately.

Whenever maintenance services are performed on the hydraulic system, it is recommended to lock all the actuators (motors and winches) in the safe positions to prevent uncontrolled movements of the equipment.

Before removing caps, plugs, and covers, relieve the internal pressures.

Be careful when using towels for cleaning hydraulics system components. Lint can clog the hydraulic circuit. When performing any maintenance on a hydraulic circuit, depressurize hoses and actuators.

Before opening the hydraulic circuit, make sure that all actuators are in their rest positions and there are no loads supported by the hydraulic oil pressure.

Failure to follow these warnings could result in death or serious injury.

⚠ WARNING

Always move the hydraulic lockout control lever to the locked (closed) position before leaving the seat or performing maintenance. Failure to follow this warning or any unintended movement of the joysticks or travel controls could result in death or serious injury.

⚠ WARNING

Compressed air can cause serious injury or death. Do not allow compressed air to contact skin. Always wear goggles, gloves, and other personal protective equipment (PPE).

NOTICE

When working without a certified lift or ladder, fall protection devices must be worn at heights above 6 ft (1.8 m).

🌱 Environment

In case of any hydraulic leak, stop the machine immediately and protect the ground to avoid environmental damage.

When replacing the products used for the equipment's operation (motor oil, hydraulic oil, etc), collect it carefully to prevent polluting the environment.

Never abandon contaminated materials in the environment. Dispose all waste in compliance with current legislation.

Safety Rules

Read and understand the following maintenance and safety rules:

- Before performing any service, move the hydraulic lockout control lever to the lock position and turn the engine off. Perform the lockout/tagout procedure before servicing the drilling rig.
- Proper maintenance is essential to ensure personnel safety and proper equipment operation.
- Follow all maintenance checks and procedures. Non-compliance may result in safety hazards, improper performance or operation, or loss of warranty coverage.
- Do not allow unauthorized or non-qualified personnel to perform maintenance on the drilling rig.
- When servicing has to be done in places that are difficult to access or dangerous, take adequate steps to ensure your own and other people's safety in compliance with current legislation concerning occupational safety.
- Do not perform any maintenance that will modify components or change original factory settings without prior authorization from CZM. This may result in loss of warranty for the equipment.
- Replace parts with factory original parts and only use recommended oils and grease. This will ensure proper operation of the drilling rig and the necessary safety level.
- When performing inspections or servicing when the engine must be running, additional personnel such as a signal person should be used to communicate between the operator and maintenance technician.
- Before disconnecting or removing components of the hydraulic system, relieve the system pressure to prevent hydraulic oil from spraying out. See the base machine manual for the steps to relieve hydraulic system pressure. See "Release of Hydraulic Pressure from the Main Hydraulic System*" on page 10-66 for additional information.
- When maintenance operation requires access to components that cannot be achieved from ground level, use ladders or platforms and the required safety equipment.
- When handling compressed air for cleaning parts, use glasses with side shields and limit the maximum pressure to 27 psi.
- Before servicing or making adjustments to the equipment, enable all the safety devices provided and consider whether it is necessary to inform the

staff involved in the procedure or operating in the vicinity of the drilling rig. In particular, provide suitable signs around the area affected and prevent access to any devices whose operation might give rise to unpredictable hazardous conditions, posing a severe risk to personal health and safety.

- Check the LR95 drilling rig daily for loose, worn, or damaged bolts.

Lockout/Tagout Procedure

Perform the lockout/tagout procedure on the drilling rig in accordance with your company policy and procedures.

Cleaning the Drilling Rig

Always use hot water and a mild, nonflammable, grease-cutting soap or cleaning solution to clean the drilling rig. Never use flammable agents.

SAFETY

Critical Failures*

The following table provides summary information on several limiting conditions found in this Operation and Maintenance Manual.

The table provides criteria and required action for the limiting conditions listed. Each System or Component in this table, together with the respective limiting condition, describes a potential critical failure that must be addressed.

Not addressing limiting conditions with required actions may, in conjunction with other factors or circumstances, result in a risk of personal injury or death. If an accident occurs, notify emergency personnel and provide the location and description of the accident.

System or Component	Limiting Condition	Criteria for Action	Required Action
Line, tubes, and hoses	<ul style="list-style-type: none"> End fittings are damaged or leaking. Outer coverings are chafed or cut. Wires are exposed. Outer coverings are swelling or ballooning. Flexible parts of the hoses are kinked. Outer covers have exposed embedded armoring. End fittings are displaced. 	<ul style="list-style-type: none"> Visible corrosion, loose, or damaged lines, tubes, or hoses. Visible fluid leaks. 	Immediately repair any lines, tubes, or hoses that are corroded, loose, or damaged. Immediately repair any leaks, as these may provide fuel for fires.
Electrical wiring	Signs of fraying, abrasion, cracking, discoloration, and cuts on the cable insulation.	Visible damage to electrical wiring.	Immediately replace damaged wiring.
Battery cable(s)	<ul style="list-style-type: none"> Signs of fraying, abrasion, cracking, discoloration, cuts on the cable insulation. Fouling, corroded terminals, damaged terminals, and loose terminals. 	Visible damage to the battery cable(s).	Immediately replace damaged battery cables.
Operator protective structure	<ul style="list-style-type: none"> Structures that are bent, cracked, or loose. Loose, missing, or damaged bolts. 	<ul style="list-style-type: none"> Visible damage to structure. Loose, missing, or damaged bolts. 	Do not operate machine with damaged structure or loose, missing, or damaged bolts. Contact CZM for inspection and repair or replacement options.
Seat belt	Worn or damaged seat belt or mounting hardware.	Visible wear or damage.	Immediately replace parts that are worn or damaged.
Seat belt	Age of seat belt.	3 years after date of installation.	Replace seat belt 3 years after date of installation.
Safety decals	Appearance of safety decals.	Damage to safety messages making them illegible.	Replace the decals if illegible.

System or Component	Limiting Condition	Criteria for Action	Required Action
Audible warning device(s) (if equipped)	Sound level of audible warning.	Reduced or no audible warning present.	Immediately repair or replace audible warning devices not working properly.
Camera(s) (if equipped)	Dirt or debris on camera lens.	Dirt or debris obstructing camera view.	Clean camera before operating machine.
Cab windows	Dirt, debris, or damaged windows.	<ul style="list-style-type: none"> Dirt or debris obstructing operator visibility. Any damaged windows. 	Clean windows before operating machine. Repair or replace damaged windows before operating machine.
Mirrors	Dirt, debris, or damaged mirror.	<ul style="list-style-type: none"> Dirt or debris obstructing operator visibility. Any damaged mirrors. 	Clean mirrors before operating the machine. Repair or replace damaged mirrors before operating the machine.
Braking system	Inadequate braking performance.	System does not pass Braking System - Test(s) included in Maintenance Section or in the Testing and Adjusting Manual.	Contact CZM to inspect and, if necessary, repair the brake system.
Cooling system	The coolant temperature is too high.	Monitoring system displays warning category 3.	Stop the engine immediately. Check the coolant level and check the radiator for debris. Refer to "Cooling System Coolant Level – Check*" on page 10-53. Check the fan drive belt for the water pump. Refer to "Belt - Inspect/Adjust/Replace*" on page 10-55. Make any necessary repairs.
Engine oil system	A problem has been detected with the engine oil pressure.	Monitoring system displays warning category 3.	If the warning stays on during low idle, stop the engine and check the engine oil level. Perform any necessary repairs as soon as possible.
Engine system	An engine fault has been detected by the engine ECM.	Monitoring system displays warning category 3.	Stop the engine immediately. Contact CZM for service.
Fuel system	A problem has been detected with the fuel system.	Monitoring system displays warning category 3.	Stop the engine. Determine the cause of the fault and perform any necessary repairs.
Hydraulic oil system	The hydraulic oil temperature is too high.	Monitoring system displays warning category 3.	Stop the engine immediately. Check the hydraulic oil level and check the hydraulic oil cooler for debris. Perform any necessary repairs as soon as possible.

SAFETY

System or Component	Limiting Condition	Criteria for Action	Required Action
Steering system	A problem has been detected with the steering system. (If equipped with steering system monitoring).	Monitoring system displays warning category 3.	Move the machine to a safe location and stop the engine immediately. Contact CZM to inspect and, if necessary, repair the steering system.
Overall machine	Machine service is required.	Monitoring system displays warning category 3.	Stop the engine immediately. Contact CZM for service.

(*) M0080149-08 ©2022 Caterpillar All Rights Reserved

Chapter 3

Stability

Stability Conditions

The stability data and diagrams in this chapter are valid for the following conditions:

Operating Condition	Value	
	Imperial	Metric
Kelly Bar – Short Mast:4/45	5,687 lb	2,585 kg
Kelly Bar – Long Mast: 4/80	10,003 lb	4,547 kg
Counterweights Installed – Short Mast	26,948 lb	12,249 kg
Counterweights Installed – Long Mast	22,956 lb	5,547 kg
Winch Pull	27,126 lbf	12,330 kgf
Drilling Tool/Auger	4,400 lb	2,000 kg
Machine Working Surface Condition	Firm, horizontal, and level operating surface.	
Wind Speed (in worst direction)	45 mph	72 km/h
Track Shoe Width	28 in.	700 mm
Machine Weight – Short Mast	98,700 lb	44,780 kg
Machine Weight – Long Mast	108,610 lb	49,280 kg
Undercarriage	Fully extended	

DANGER

If the drilling rig is to be operated in conditions/configuration other than those specified here, contact CZM for the stability and ground pressure data. Failure to adhere to proper stability limits will result in death, serious injury, or damage to the drilling rig.

Stability Calculation Method

- Calculations made according to guidelines established by the European Standard BS EN 16228-1:2014.
- Where applicable the values shown, including ground pressures, are only valid for the drilling rig in the positions described. The boom/parallelogram position will affect stability values.
- Kelly mode: Using the main winch on the kelly bar (no crowd winch). Mast footpad is not engaged on the ground.
- Dynamic forces: Wind pressure & extraction force.
- Ground pressure *Contact Length is calculated according to BS EN 16228-1:2014.

NOTES:

- Additional conditions/restrictions may be present for specific operating modes and machine positioning. Refer to the respective operating mode.
- For stability and ground pressure information when the machine is not under the influence of strong winds, contact the CZM After Sales department.
- CZM USA CORP reserves the right to make changes and improvements to its products at any time and without notice to constantly increase their quality; therefore, the stability charts may also be subject to future changes.

STABILITY

Short Mast

Traveling Stability – Forward Facing

Traveling Stability – Forward Facing				
Distance (d)	Stability Angle (a)	Uniform Ground Pressure (G.P.) at Contact Length*	C.G.	
			X	Y
3 ft 2 in (845 mm)	41.4 Degrees	10.37 psi (0.73 kgf/cm ²)	7 ft 4 in (2,246 mm)	8 ft 4 in (2,548 mm)

Stability angle (a) – The stability angle is calculated according to European Standard BS EN 16228-1:2014.

- Values in above table are valid with these conditions:
- Mast is in upright position.
 - Boom is all the way back.
 - Suspended loads: (kelly bar, tooling, rotary) lowered as close to the ground as possible.

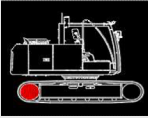
	Undercarriage Drive Motor Rear Maximum Ground Pressure	
	PSI	Kgf/cm ²
A	8.9	0.62
B	11.9	0.84

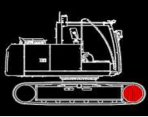
	Undercarriage Drive Motor Front Maximum Ground Pressure	
	PSI	Kgf/cm ²
A	9.7	0.68
B	11.0	0.77

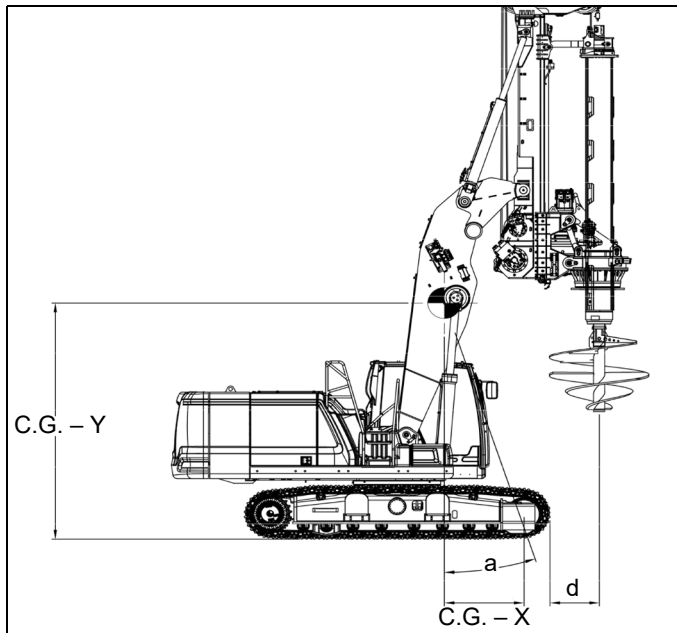

Figure 3-2: Forward Facing Travel Stability

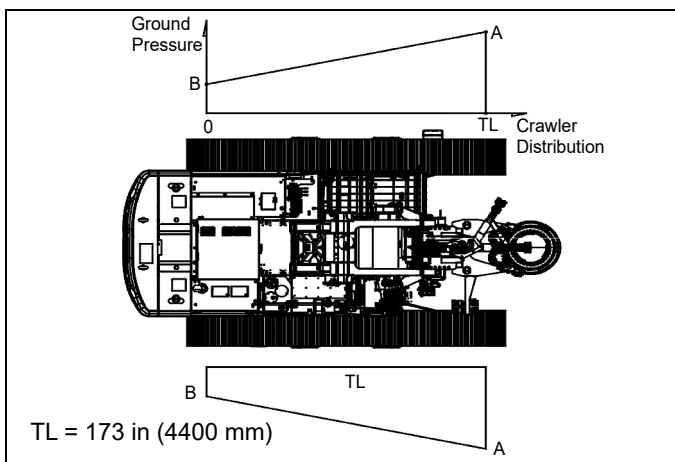

Figure 3-1: Ground Pressure - Forward Facing

Short Mast (continued) Traveling Stability – Off the Side

Traveling Stability – Off the Side				
Distance (d)	Stability Angle (a)	Uniform Ground Pressure (G.P.) at Contact Length*	C.G.	
			X	Y
4 ft 8 in (1,412 mm)	37.3 Degrees	10.38 psi (0.73 kgf/cm ²)	6 ft 4 in (1,939 mm)	8 ft 4in (2,548 mm)

Stability angle (a) – The stability angle is calculated according to European Standard BS EN 16228-1:2014.

- Values in above table are valid with these conditions:
- Mast is in upright position.
 - Boom is all the way back.
 - Suspended loads: (kelly bar, tooling, rotary) lowered as close to the ground as possible.

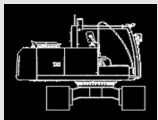
	Over Side Maximum Ground Pressure	
	PSI	Kgf/cm ²
A	10.0	0.70
B	10.8	0.76

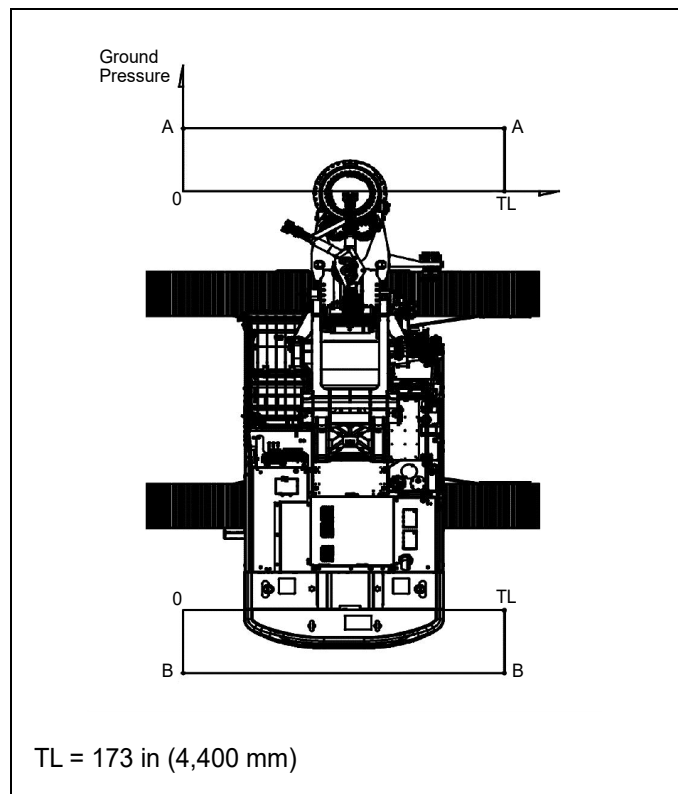

Figure 3-3: Ground Pressure - Off the Side

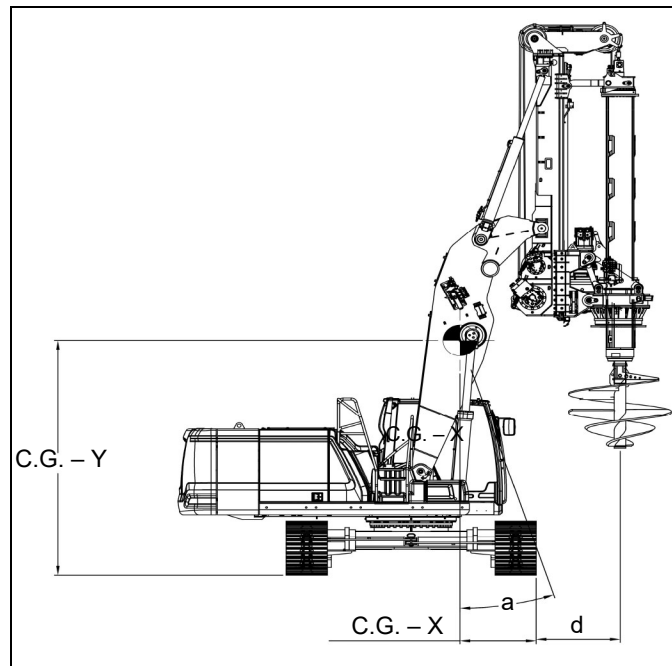

Figure 3-4: Off the Side Travel Stability

0001917

0001849

STABILITY

Short Mast (continued) Drilling Stability – Forward Facing

Drilling Stability – Facing Forward				
Distance (d)	Stability Angle (a)	Uniform Ground Pressure (G.P.) at Contact Length*	C.G.	
			X	Y
3 ft 2 in (954 mm)	40.3 Degrees	12.45 psi (0.88 kgf/cm ²)	6 ft 6 in (1,983 mm)	7 ft 8 in (2,338 mm)
8 ft 4 in (2,534 mm)	30.2 Degrees	14.9 psi (1.05 kgf/cm ²)	4 ft 0 in (1,230 mm)	6 ft 11 in (2,114 mm)
13 ft 6 in (4,114 mm)	17.6 Degrees	39.8 psi (2.80 kgf/cm ²)	1 ft 6 in (466 mm)	4 ft 10 in (1,469 mm)

Stability angle (a) – The stability angle is calculated according to European Standard BS EN 16228-1:2014.

Values in above table are valid with these conditions:
• Mast is in upright position.
• Rotary in the top position on the mast.
• Kelly bar open. Tool just below ground level.

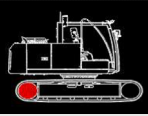
Undercarriage - Drive Motor Rear Maximum Ground Pressure				
	Ground Pressure		Contact Length	
	PSI	Kgf/cm ²	in.	mm
A (d)	15.1	1.07	173	4,400
A (d')	28.4	2.00	152	3,870
A (d'')	70.3	4.95	62	1,580
B	9.8	0.69		

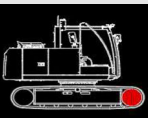
Undercarriage - Drive Motor Front Maximum Ground Pressure				
	Ground Pressure		Contact Length	
	PSI	Kgf/cm ²	in.	mm
A (d)	16.1	1.14	173	4,400
A (d')	29.8	2.10	145	3,689
A (d'')	79.6	5.61	55	1,399
B	8.7	0.61		

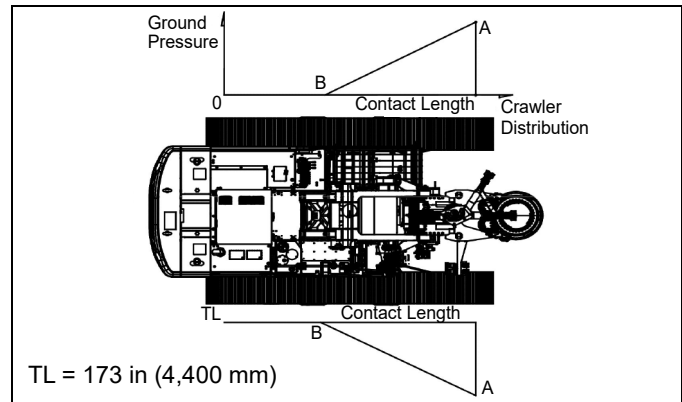

Figure 3-5: Ground Pressure - Forward Facing

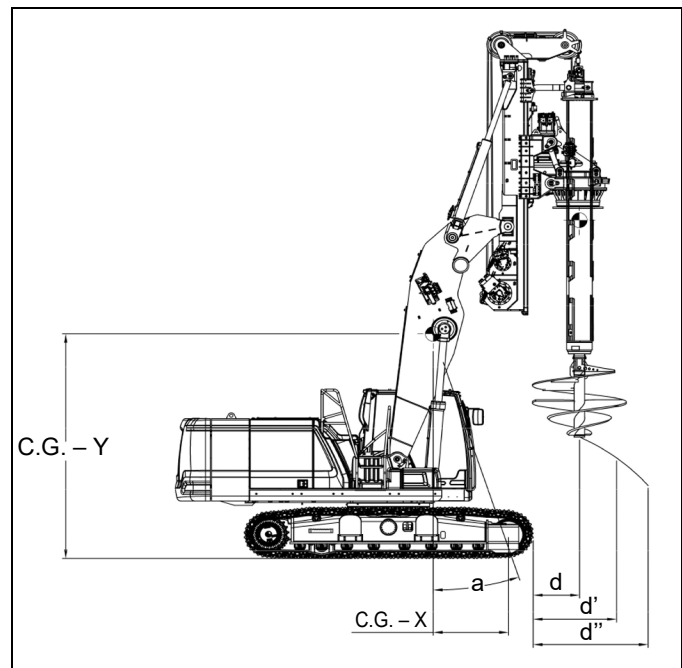

Figure 3-6: Drilling Stability Forward Facing

Short Mast (continued) Drilling Stability – Off the Side

Drilling Stability – Off the Side				
Distance (d)	Stability Angle (a)	Uniform Ground Pressure (G.P.) at Contact Length*	C.G.	
			X	Y
4 ft 8 in (1,412 mm)	34.5 Degrees	12.46 psi (0.88 kgf/cm ²)	5 ft 3 in (1,608 mm)	7 ft 8 in (2,338 mm)
9 ft 8 in (2,947 mm)	22.4 Degrees	12.53 psi (0.88 kgf/cm ²)	2 ft 10 in (876 mm)	6 ft 12 in (2,123 mm)
14 ft 8 in (4,483 mm)	5.0 Degrees	13.28 psi (0.94 kgf/cm ²)	0 ft 5 in (136 mm)	5 ft 1 in (1,554 mm)

Stability angle (a) – The stability angle is calculated according to European Standard BS EN 16228-1:2014.

- Values in above table are valid with these conditions:
- Mast is in upright position.
 - Rotary in the top position on the mast.
 - Kelly bar open. Tool just below ground level.

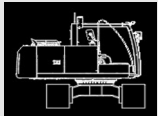
	Off the Side Maximum Ground Pressure	
	PSI	Kgf/cm ²
A (d)	14.2	1.00
B (d)	10.8	0.76
A (d')	19.2	1.35
B (d')	5.9	0.42
A (d'')	25.6	1.80
B (d'')	1.0	0.07

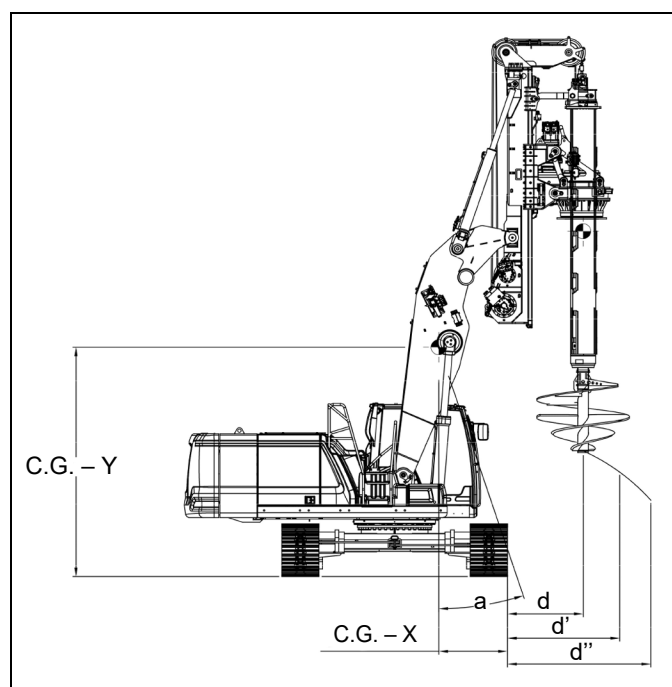

Figure 3-8 Off the Side Drilling Stability

0001919

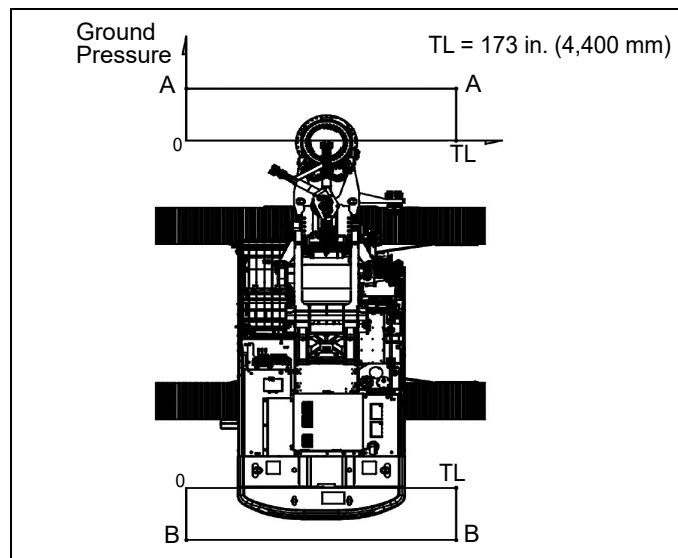

Figure 3-7: Ground Pressure - Off the Side

0001855

STABILITY

Short Mast (continued)

Auxiliary Winch Stability – Forward Facing

Auxiliary Winch Stability – Forward Facing				
Distance (d)	Stability Angle (a)	Uniform Ground Pressure (G.P.) at Contact Length*	C.G.	
			X	Y
5 ft 1 in (1,541 mm)	40.8 Degrees	11.9 psi (0.84 kgf/cm ²)	6 ft 7 in (2,001 mm)	7 ft 7 in (2,318 mm)
Maximum line pull: 14,300 lb (6,500 kg)				
Stability angle (a) – The stability angle is calculated according to European Standard BS EN 16228-1:2014.				

Values in above table are valid with these conditions:
• Mast is tilted forward 10 degrees.
• Boom is all the way back.
• Suspended loads: (kelly bar, tooling, rotary) lowered as close to the ground as possible.

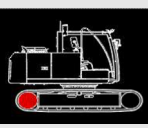
Undercarriage - Drive Motor Rear Maximum Ground Pressure				
	Ground Pressure		Contact Length	
	PSI	Kgf/cm ²	in	mm
A	14.1	1.00	173	4,400
B	9.6	0.68		

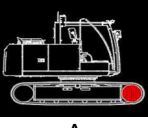
Undercarriage - Drive Motor Front Maximum Ground Pressure				
	Ground Pressure		Contact Length	
	PSI	Kgf/cm ²	in	mm
A	15.1	1.06	173	4,400
B	8.6	0.61		

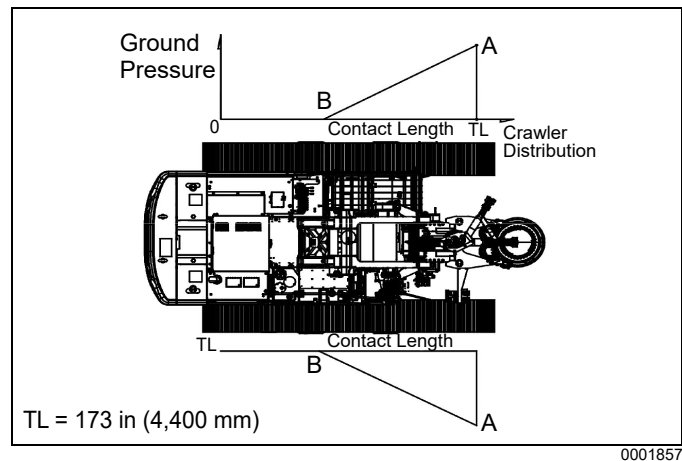

Figure 3-9: Ground Pressure Forward Facing

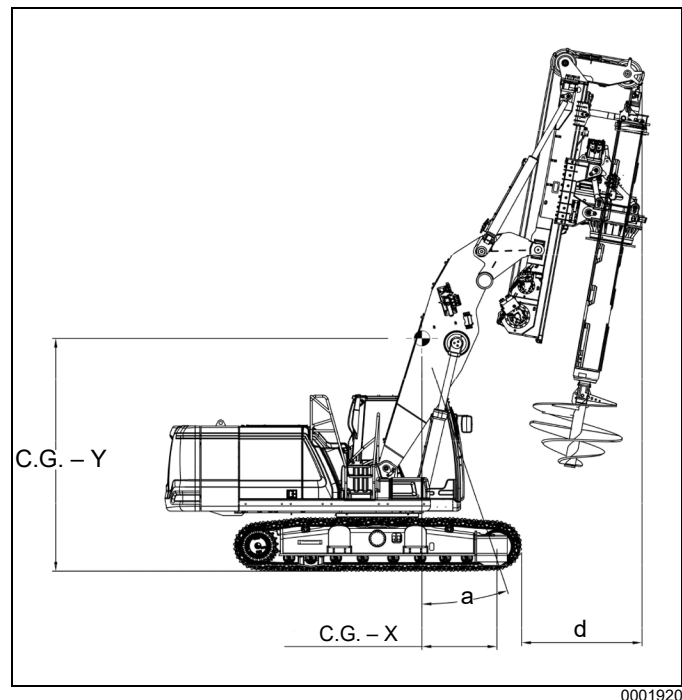
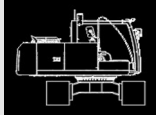

Figure 3-10: Auxiliary Winch Forward Stability

Short Mast (continued) Auxiliary Winch Stability – Off the Side

Auxiliary Winch Stability – Off the Side				
Distance (d)	Stability Angle (a)	Uniform Ground Pressure (G.P.) at Contact Length*	C.G.	
			X	Y
6 ft 7 in (1,999 mm)	35.4 Degrees	11.9 psi (0.84 kgf/cm ²)	5 ft 5 in (1,645 mm)	7 ft 7 in (2,318 mm)
Maximum line pull: 11,440 lb (5,200 kg)				
Stability angle (a) – The stability angle is calculated according to European Standard BS EN 16228-1:2014.				

- Values in above table are valid with these conditions:
- Mast tilted forward 10 degrees.
 - Boom is all the way back.
 - Suspended loads: (kelly bar, tooling, rotary) lowered as close to the ground as possible.

	Undercarriage Drive Motor Front Maximum Ground Pressure	
	PSI	Kgf/cm ²
A (d)	13.3	0.94
B (d)	10.5	0.74

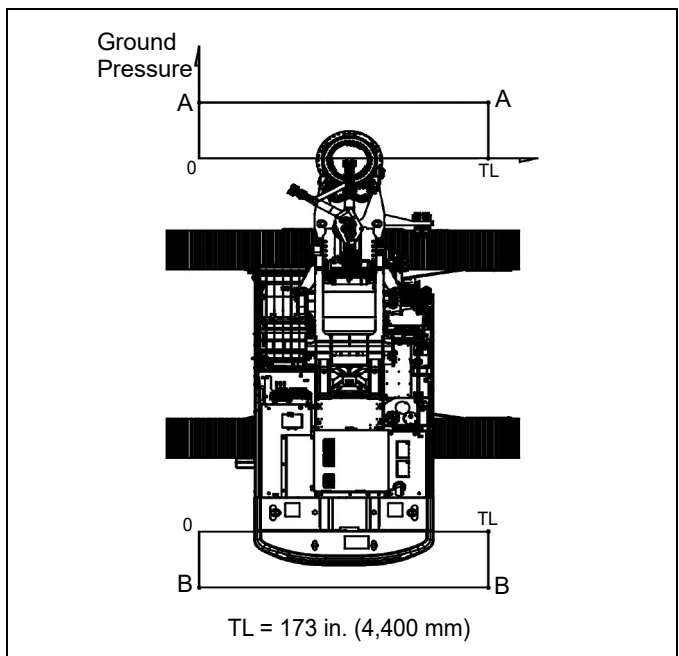

Figure 3-11: Ground Pressure Off the Side

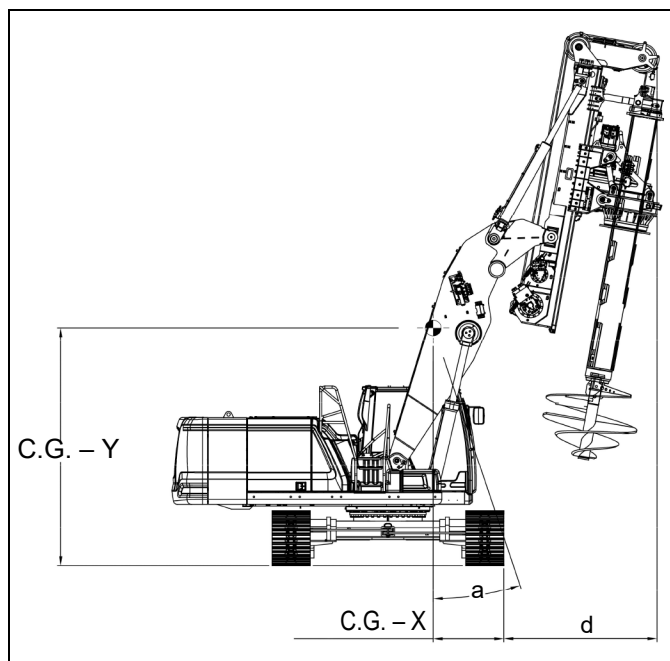

Figure 3-12: Aux. Winch Off the Side Stability

STABILITY

Long Mast

Traveling Stability – Forward Facing

Traveling Stability – Forward Facing				
Distance (d)	Stability Angle (a)	Uniform Ground Pressure (G.P.) at Contact Length*	C.G.	
			X	Y
3 ft 2 in (954 mm)	35.8 Degrees	11.57 psi (0.82 kgf/cm ²)	7 ft 0 in (2,136 mm)	9 ft 9 in (2,964 mm)

Stability angle (a) – The stability angle is calculated according to European Standard BS EN 16228-1:2014.

Values in above table are valid with these conditions:
• Mast is in upright position.
• Boom is all the way back.
• Suspended loads: (kelly bar, tooling, rotary) lowered as close to the ground as possible.

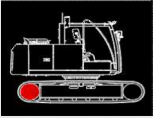
	Undercarriage Drive Motor Rear Maximum Ground Pressure	
	PSI	Kgf/cm ²
A	11.7	0.82
B	11.4	0.80

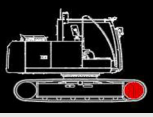
	Undercarriage Drive Motor Front Maximum Ground Pressure	
	PSI	Kgf/cm ²
A	12.6	0.89
B	10.4	0.73

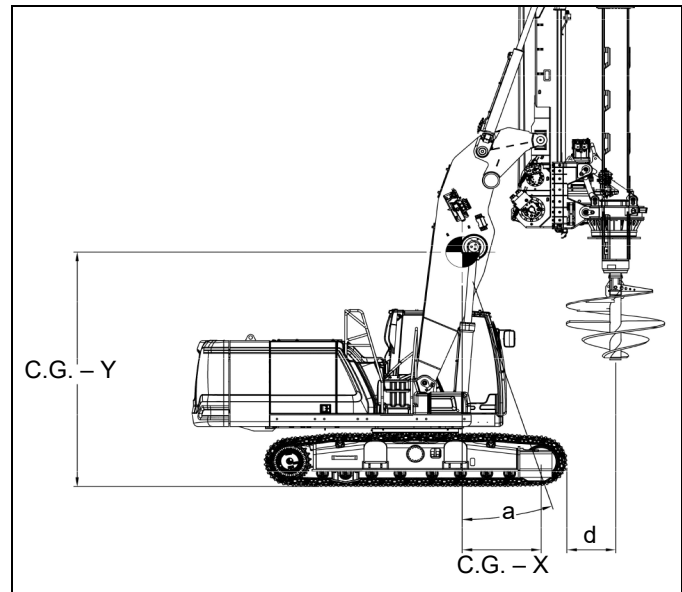

Figure 3-14: Forward Facing Travel Stability

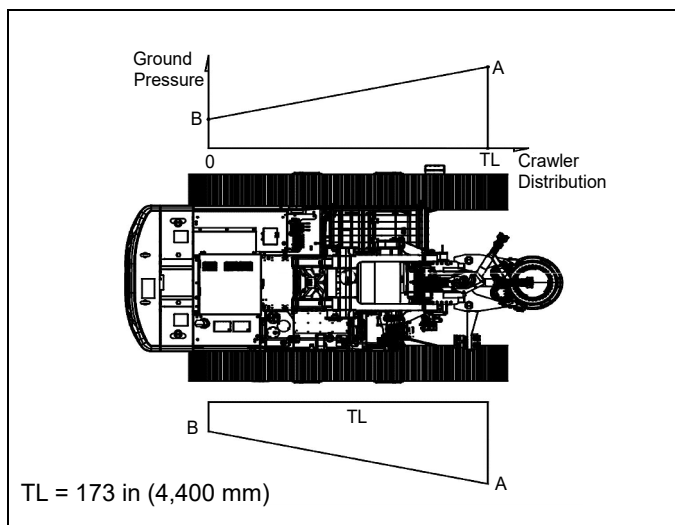

Figure 3-13: Ground Pressure - Forward Facing

Long Mast (Continued) Traveling Stability – Off the Side

Traveling Stability – Off the Side				
Distance (d)	Stability Angle (a)	Uniform Ground Pressure (G.P.) at Contact Length*	C.G.	
			X	Y
4 ft 8 in (1,412 mm)	31.6 Degrees	11.61 psi (0.82 kgf/cm ²)	5 ft 12 in (1,826 mm)	9 ft 9 in (2,964 mm)

Stability angle (a) – The stability angle is calculated according to European Standard BS EN 16228-1:2014.

- Values in above table are valid with these conditions:
- Mast is in upright position.
 - Boom is all the way back.
 - Suspended loads: (kelly bar, tooling, rotary) lowered as close to the ground as possible.

	Over Side Maximum Ground Pressure	
	PSI	Kgf/cm ²
A	11.8	0.83
B	11.4	0.80

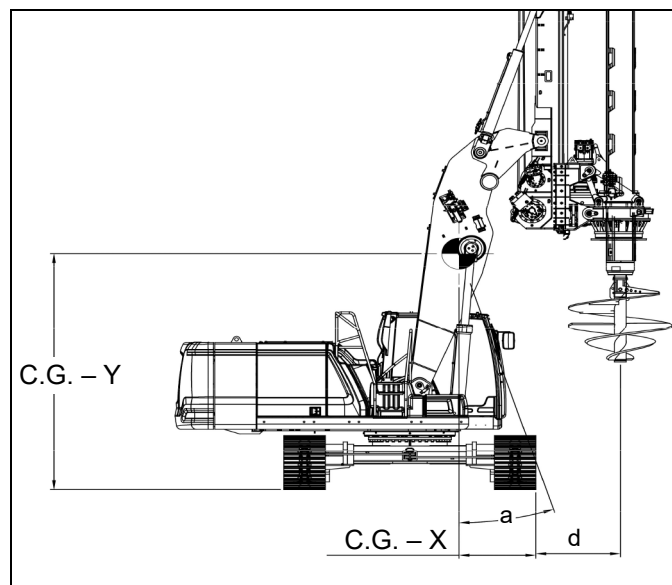

Figure 3-16: Off the Side Travel Stability

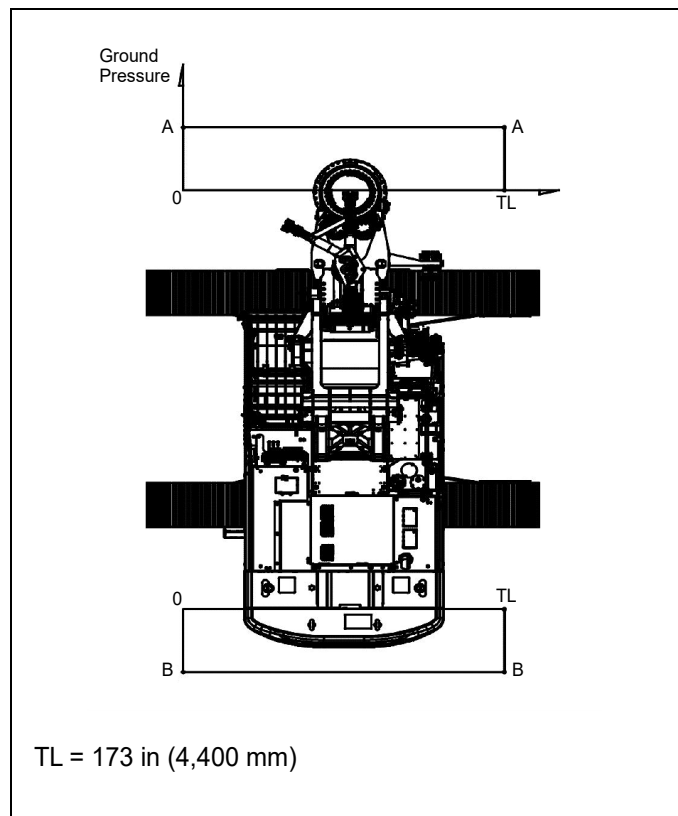

Figure 3-15: Ground Pressure - Off the Side

STABILITY

Long Mast (Continued) Drilling Stability – Forward Facing

Drilling Stability – Facing Forward				
Distance (d)	Stability Angle (a)	Uniform Ground Pressure (G.P.) at Contact Length*	C.G.	
			X	Y
3 ft 2 in (954 mm)	36.5 Degrees	13.21 psi (0.93 kgf/cm ²)	6 ft 5 in (1,947 mm)	8 ft 7 in (2,628 mm)
8 ft 4 in (2,534 mm)	27.0 Degrees	15.8 psi (1.11 kgf/cm ²)	4 ft 11 in (1,240 mm)	7 ft 0 in (2,136 mm)
13 ft 6 in (4,114 mm)	15.6 Degrees	38.9 psi (2.74 kgf/cm ²)	1 ft 9 in (523 mm)	6 ft 1 in (1,960 mm)

Stability angle (a) – The stability angle is calculated according to European Standard BS EN 16228-1:2014.

Values in above table are valid with these conditions:
• Mast is in upright position.
• Rotary in the top position on the mast.
• Kelly bar open. Tool just below ground level.

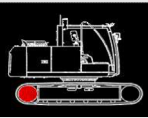
Undercarriage - Drive Motor Rear Maximum Ground Pressure				
	Ground Pressure		Contact Length	
	PSI	Kgf/cm ²	in.	mm
A (d)	16.8	1.18	173	4,400
A (d')	30.2	2.13	153	3,883
A (d'')	69.9	4.93	68	1,732
B	9.6	0.68		

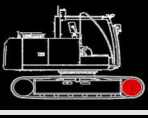
Undercarriage - Drive Motor Front Maximum Ground Pressure				
	Ground Pressure		Contact Length	
	PSI	Kgf/cm ²	in.	mm
A (d)	17.8	1.25	173	4,400
A (d')	31.6	2.22	146	3,719
A (d'')	77.7	5.48	62	1,568
B (d'')	8.5	0.60		

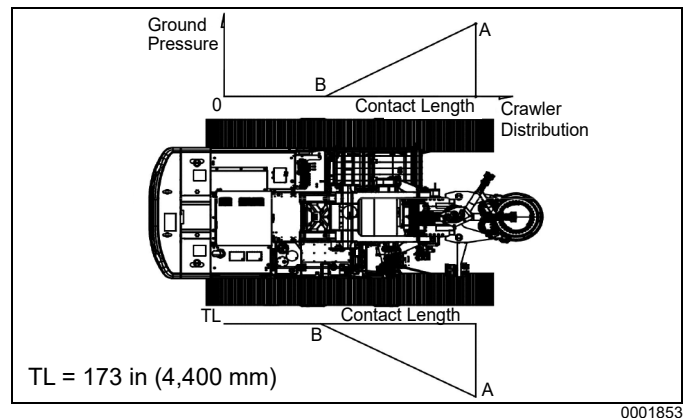

Figure 3-17: Ground Pressure - Forward Facing

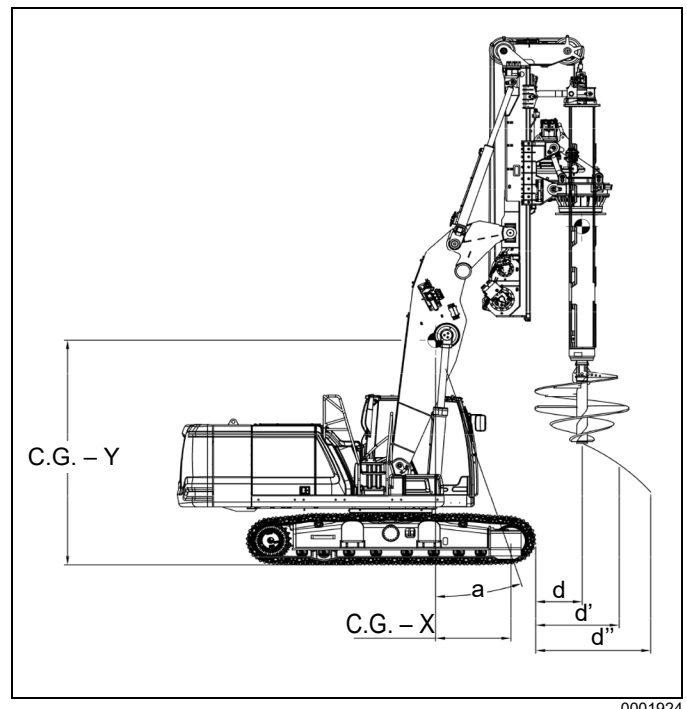

Figure 3-18: Drilling Stability Forward Facing

Long Mast (Continued) Drilling Stability – Off the Side

Drilling Stability – Off the Side				
Distance (d)	Stability Angle (a)	Uniform Ground Pressure (G.P.) at Contact Length*	C.G.	
			X	Y
4 ft 8 in (1,412 mm)	31.2 Degrees	13.26 psi (0.93 kgf/cm ²)	5 ft 3 in (1,589 mm)	8 ft 7 in (2,628 mm)
9 ft 10 in (2,992 mm)	19.9 Degrees	13.49 psi (0.95 kgf/cm ²)	2 ft 11 in (882 mm)	7 ft 12 in (2,436 mm)
15 ft 10 in (4,572 mm)	5.0 Degrees	15.76 psi (1.11 kgf/cm ²)	0 ft 6 in (165 mm)	6 ft 1 in (1,866 mm)

Stability angle (a) – The stability angle is calculated according to European Standard BS EN 16228-1:2014.

- Values in above table are valid with these conditions:
- Mast is in upright position.
 - Rotary in the top position on the mast.
 - Kelly bar open. Tool just below ground level.

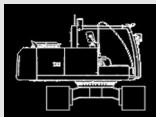
	Off the Side Maximum Ground Pressure	
	PSI	Kgf/cm ²
A (d)	15.2	1.07
B (d)	11.3	0.80
A (d')	20.6	1.45
B (d')	6.4	0.45
A (d'')	30.1	2.12
B (d'')	1.4	0.10

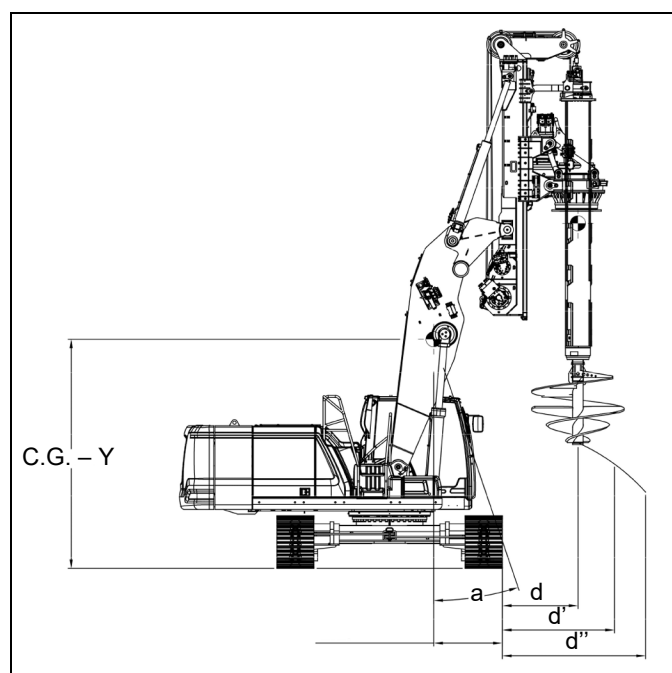
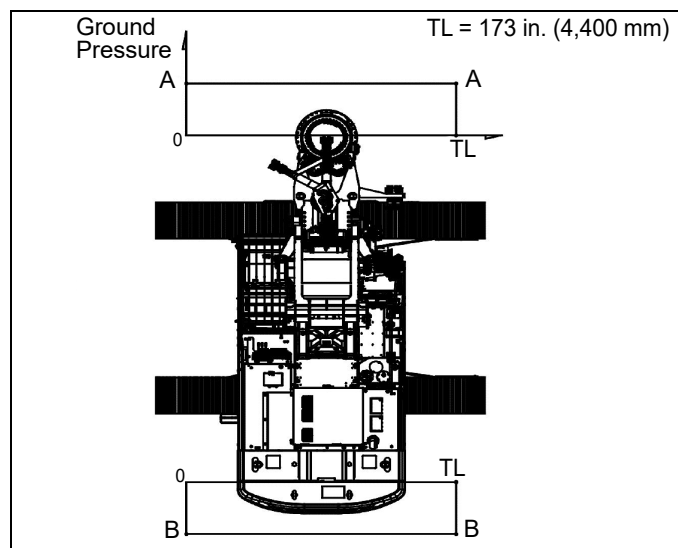

Figure 3-20 Off the Side Drilling Stability

0001925



0001855

Figure 3-19: Ground Pressure - Off the Side

STABILITY

Long Mast (Continued) Auxiliary Winch Stability – Forward Facing

Auxiliary Winch Stability – Forward Facing				
Distance (d)	Stability Angle (a)	Uniform Ground Pressure (G.P.) at Contact Length*	C.G.	
			X	Y
10 ft 2 in (3,095 mm)	32.4 Degrees	13.1 psi (0.92 kgf/cm ²)	5 ft 6 in (1,688 mm)	8 ft 9 in (2,656 mm)
Maximum line pull: 14,300 lb (6,500 kg)				
Stability angle (a) – The stability angle is calculated according to European Standard BS EN 16228-1:2014.				

Values in above table are valid with these conditions:
• Mast is tilted forward 30 degrees.
• Boom is all the way back.
• Suspended loads: (kelly bar, tooling, rotary) lowered as close to the ground as possible.

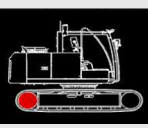
Undercarriage - Drive Motor Rear Maximum Ground Pressure				
	Ground Pressure		Contact Length	
	PSI	Kgf/cm ²	in	mm
A	21.3	1.50	173	4,400
B	4.9	0.35		

Undercarriage - Drive Motor Front Maximum Ground Pressure				
	Ground Pressure		Contact Length	
	PSI	Kgf/cm ²	in	mm
A	22.3	1.57	173	4,400
B	3.9	0.27		

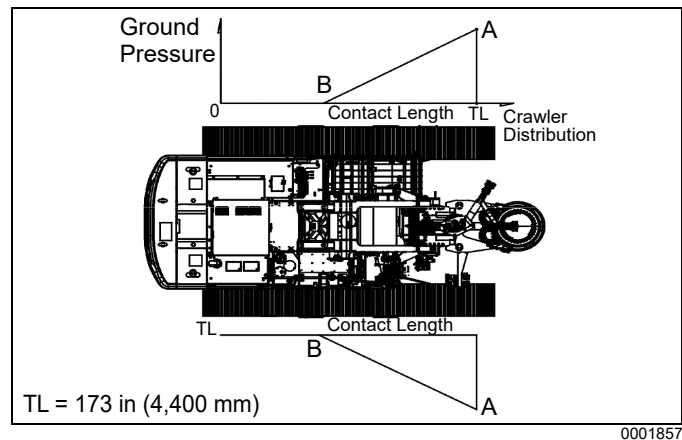

Figure 3-21: Ground Pressure Forward Facing

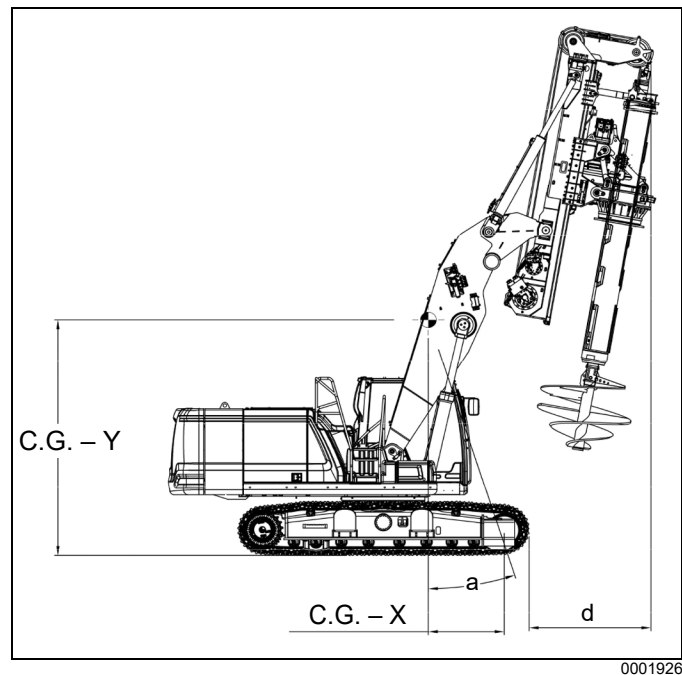
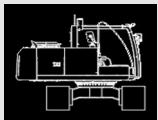

Figure 3-22: Auxiliary Winch Forward Stability

Long Mast (Continued) Auxiliary Winch Stability – Off the Side

Auxiliary Winch Stability – Off the Side				
Distance (d)	Stability Angle (a)	Uniform Ground Pressure (G.P.) at Contact Length*	C.G.	
			X	Y
11 ft 8 in (3,553 mm)	26.7 Degrees	13.2 psi (0.93 kgf/cm ²)	4 ft 5 in (1,334 mm)	8 ft 9 in (2,656 mm)
Maximum line pull: 14,300 lb (6,500 kg)				
Stability angle (a) – The stability angle is calculated according to European Standard BS EN 16228-1:2014.				

Values in above table are valid with these conditions:
• Mast tilted forward 30 degrees.
• Boom is all the way back.
• Suspended loads: (kelly bar, tooling, rotary) lowered as close to the ground as possible.

	Undercarriage Drive Motor Front Maximum Ground Pressure	
	PSI	Kgf/cm ²
A (d)	16.9	1.19
B (d)	9.4	0.67

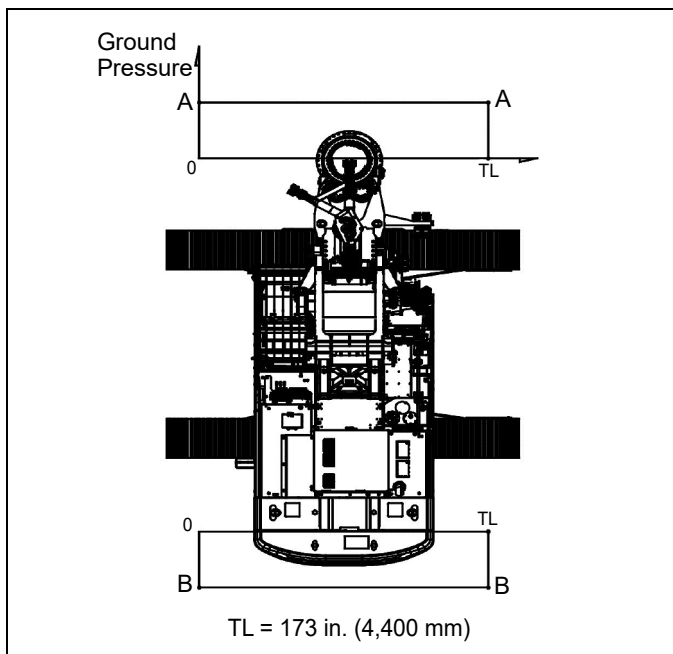

Figure 3-23: Ground Pressure Off the Side

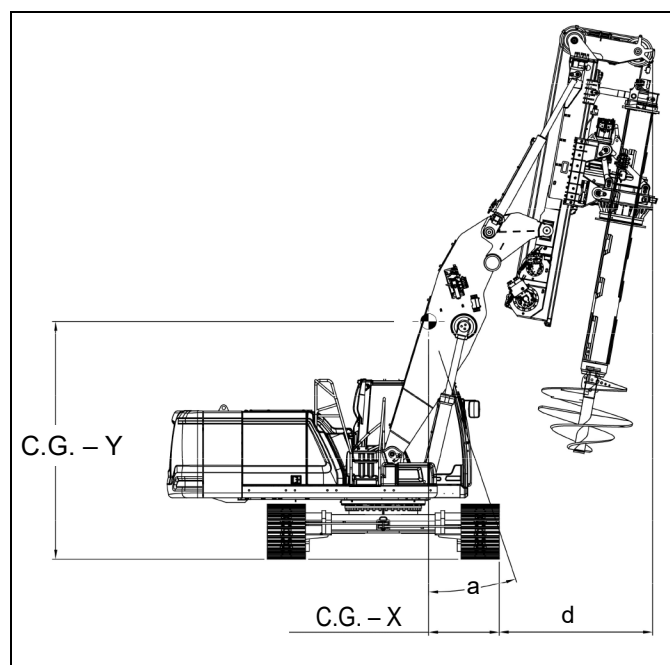

Figure 3-24: Aux. Winch Off the Side Stability

Page Intentionally Left Blank

Chapter 4

Technical Specifications

Drilling Rig Specifications

Kelly Bar Short Mast Application

Drilling Depth (five elements, interlocking kelly bar)*	53 ft	16,150 mm
Maximum Drilling Depth (interlocking bars)	80 ft	24,380 mm
Maximum Drilling Depth (friction bars)	100 ft	30,480 mm
Drilling Diameter	11 ft	3,350 mm

* For longer bars, a mast extension is required.

Rotary Head – RT 406 - 10 (Standard)

Maximum Torque (nominal)	106,300 lb-ft	14,600 kgm
Working Speed of Rotation	13 – 35 rpm	
Spin-off Rotation	78 – 129 rpm	

Crowd System

Cylinder Stroke - Short Mast	6 ft 3 in.	1,920 mm
Cylinder Push Force	15,570 lbf	7,000 kgf
Cylinder Push Speed	128 ft/min	33 m/min
Cylinder Pull Force	27,100 lbf	12,330 kgf
Cylinder Pull Speed	118 ft/min	36 m/min

Mast Inclination

Backward	5° – 15°
Forward	15°
Sideways	15° left / 15° right

Main Winch

Maximum Pull-force - 1st Layer (effective)	27,120 lbf	12,330 kgf
Line speed - 1st Layer	440 ft/min	135 m/min
Cable Diameter	5/8 in.	16 mm
Drum Diameter - 1st Layer	15.75 in	400 mm

Auxiliary Winch

Maximum Pull-force - 1st Layer (effective)	11,530 lbf	5,230 kgf
Cable Diameter	5/8 in.	16 mm
Drum Diameter - 1st Layer	12.6 in.	320 mm

TECHNICAL SPECIFICATIONS

Diesel Engine CAT®330 Next Gen Tier IV (CAT® C7.1 ACERT™)

Net Power – SAE J1349	273 hp	203 kW
Displacement	428 in. ³	7.1 L
Fuel Tank	125 gal	474 L

CAT, CATERPILLAR, their respective logos, ACERT, SoOoS, "Caterpillar Yellow" and the "Power Edge" trade dress, as well as corporate and product identity used herein, are trademarks of Caterpillar and may not be used without permission.

Hydraulic System

Hydraulic Pressure	5,076 psi	350 bar
Flow Rate (main circuit)	2 x 74 gal/min	2 x 280 L/min
Hydraulic Oil Tank Capacity	38.8 gal	147 L
Flow Rate (auxiliary circuit)	43.6 gal/min	165 L/min

Undercarriage

Track Length	17 ft.	5,200 mm
Length to Center of Rollers	14 ft. 5 in.	4,400 mm
Transport Position Width (retracted)	9 ft.11 in.	3,000 mm
Working Position Width (extended)	14 ft.	4,270 mm
Shoe Width	28 in.	700 mm
Maximum Drawbar Pull (both tracks)	92,299 lbf	41,800 kgf
Maximum Travel Speed	1.3 mph	2.0 km/h

Transport

Transport Height	10 ft. 4 in.	3,160 mm
Transport Length (Short Mast)	40 ft. 11 in.	12,475 mm
Transport Length (Long Mast)	55 ft. 9 in.	17,000 mm
Transport Width	9 ft. 6 in.	2,900 mm
Minimum Transport Weight (Short Mast - Auger Removed)	101,000 lb	45,900 kg
Minimum Transport Weight (Long Mast - Auger Removed)	101,600 lb	46,500 kg

Short Mast General Data

Overall Height (boom in)	33 ft. 2 in.	10,100 mm
Overall Height (boom out)	20 ft. 5 in.	6,260 mm
Operating Weight	102,400 lb	46,500 kg

Long Mast General Data

Overall Height (boom in)	41 ft. 4 in.	12,600 mm
Overall Height (boom out)	28 ft. 9 in.	8,760 mm
Operating Weight	103,000 lb	46,700 kg

LR95 Kelly Bar Options

Type	Number of Elements	Drilling Depth	Closed Length	Weight
4/53 Interlock	4	53 ft. (16 m)	17 ft. 2 in. (5.2 m)	6,400 lbs (2,900 kg)
5/55 Interlock	5	55 ft. (16.8 m)	15 ft. 2 in. (4.6 m)	6,800 lbs (3,100 kg)
4/80 Interlock	4	80 ft. (24 m)	23 ft. 11 in. (7.3 m)	9,600 lbs (4,300 kg)
5/55 Friction	5	55 ft. (16.8 m)	15 ft. 2 in. (4.6 m)	6,800 lbs (3,100 kg)
5/70 Friction	5	70 ft. (21 m)	18 ft. 2 in. (5.5 m)	8,600 lbs (3,900 kg)
5/100 Friction	5	100 ft. (30.5 m)	24 ft. 2 in. (4.6 m)	12,200 lbs (5,500 kg)

⚠ CAUTION

Before using a 5-element kelly bar, the rotary torque must be reduced by a CZM technician. Failure to adjust the rotary may damage the kelly bar.

Rotary Head Dimensions

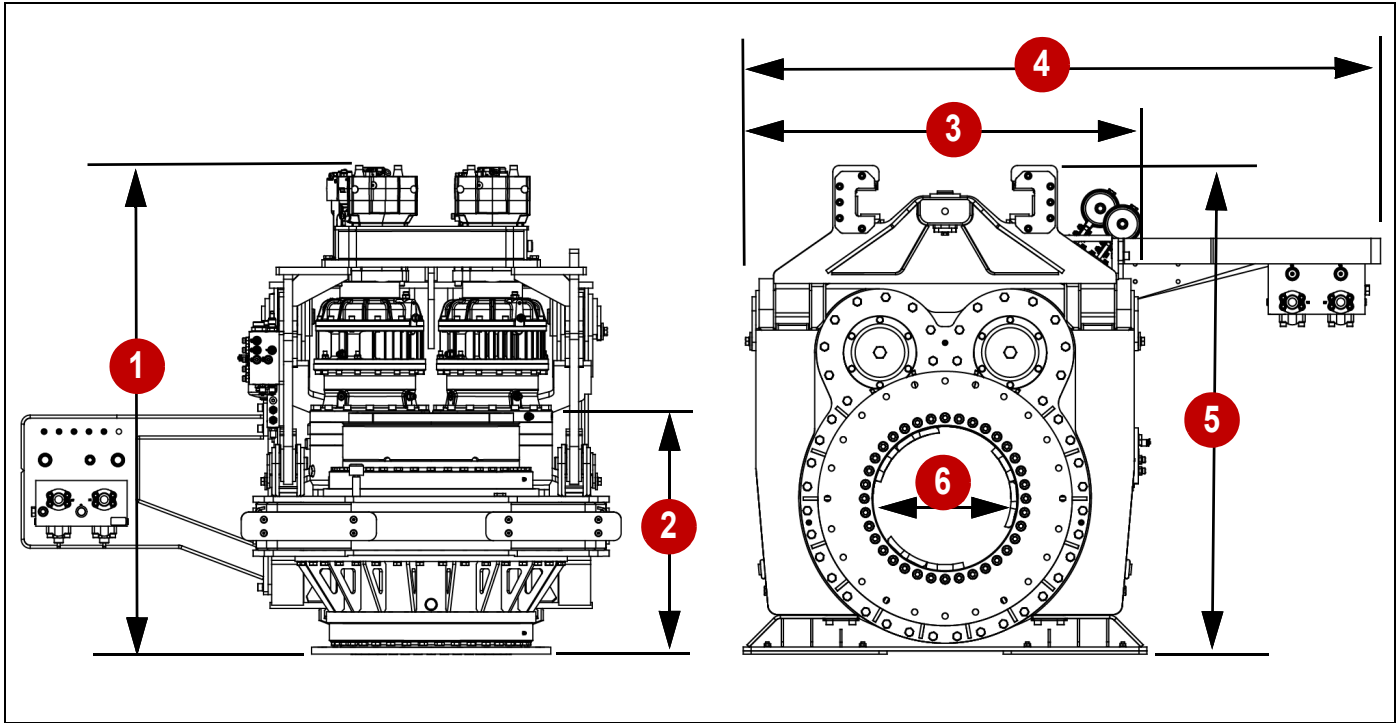

0001931 0001930

Figure 4-1

1) Rotary Head Overall Height	64.3 in.	1632 mm
2) Rotary Head Height	31.7 in.	805 mm
3) Rotary Head Width	50 in.	1270 mm
4) Rotary Head Width (with Manifold)	78.9 in.	2005 mm
5) Rotary Head Length	60.6 in.	1538 mm
6) Rotary Head Inside Diameter (ID)	16.3 in.	415 mm

Torque Diagrams

Torque x Working Speed (Nominal) Diagram

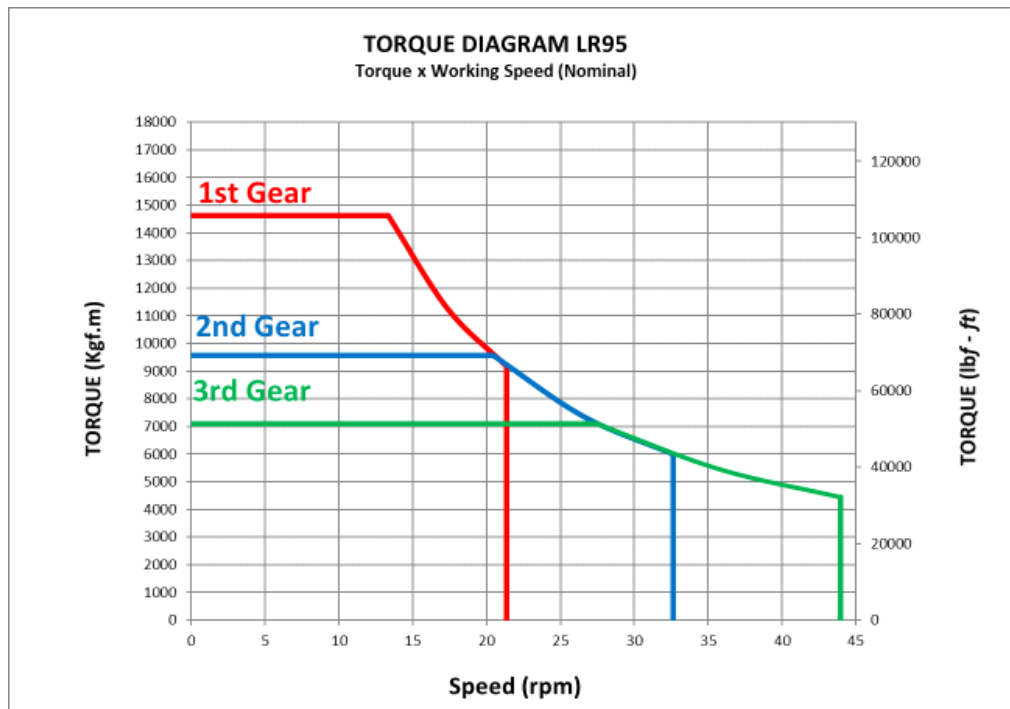

0001938

Torque x Spin-off (Nominal) Diagram

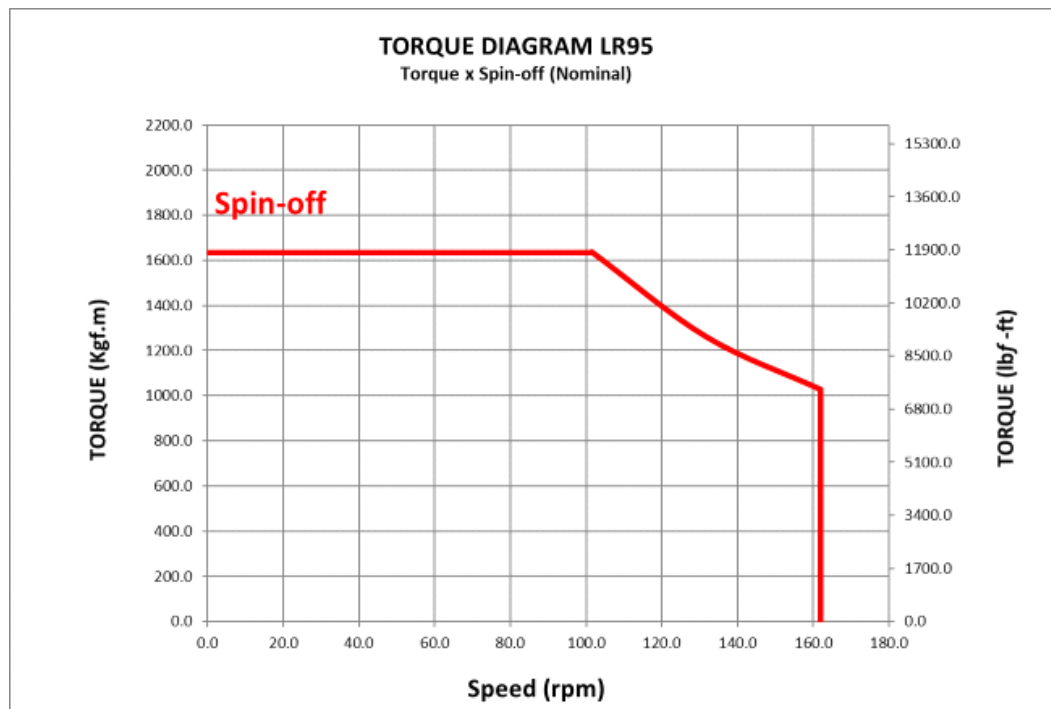

Figure 4-2

0001939

Page Intentionally Left Blank

Chapter 5

General Dimensions

Working Position Short Mast (Boom Up)

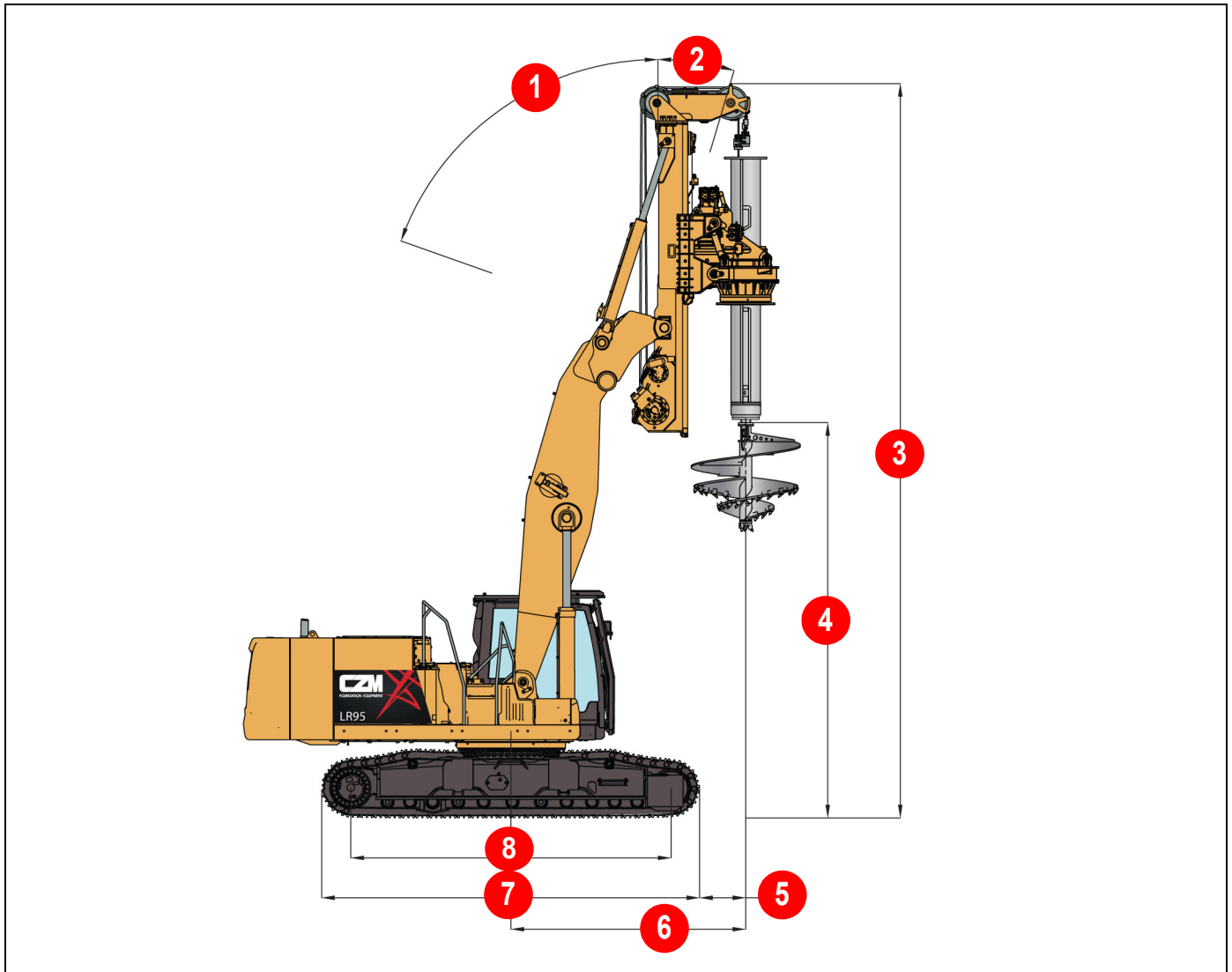

- 1) 70°
- 2) 15°
- 3) 33 ft 2 in. (10.1 m)

- 4) 17 ft 10 in. (5,440 mm)
- 5) 2 ft 1 in. (120 mm)
- 6) 10 ft 9 in. (3,230 mm)

- 7) 17 ft (5,190 mm)
- 8) 14 ft 5 in. (4,400 mm)

0001914

GENERAL DIMENSIONS

Working Position Short Mast (Boom Forward)

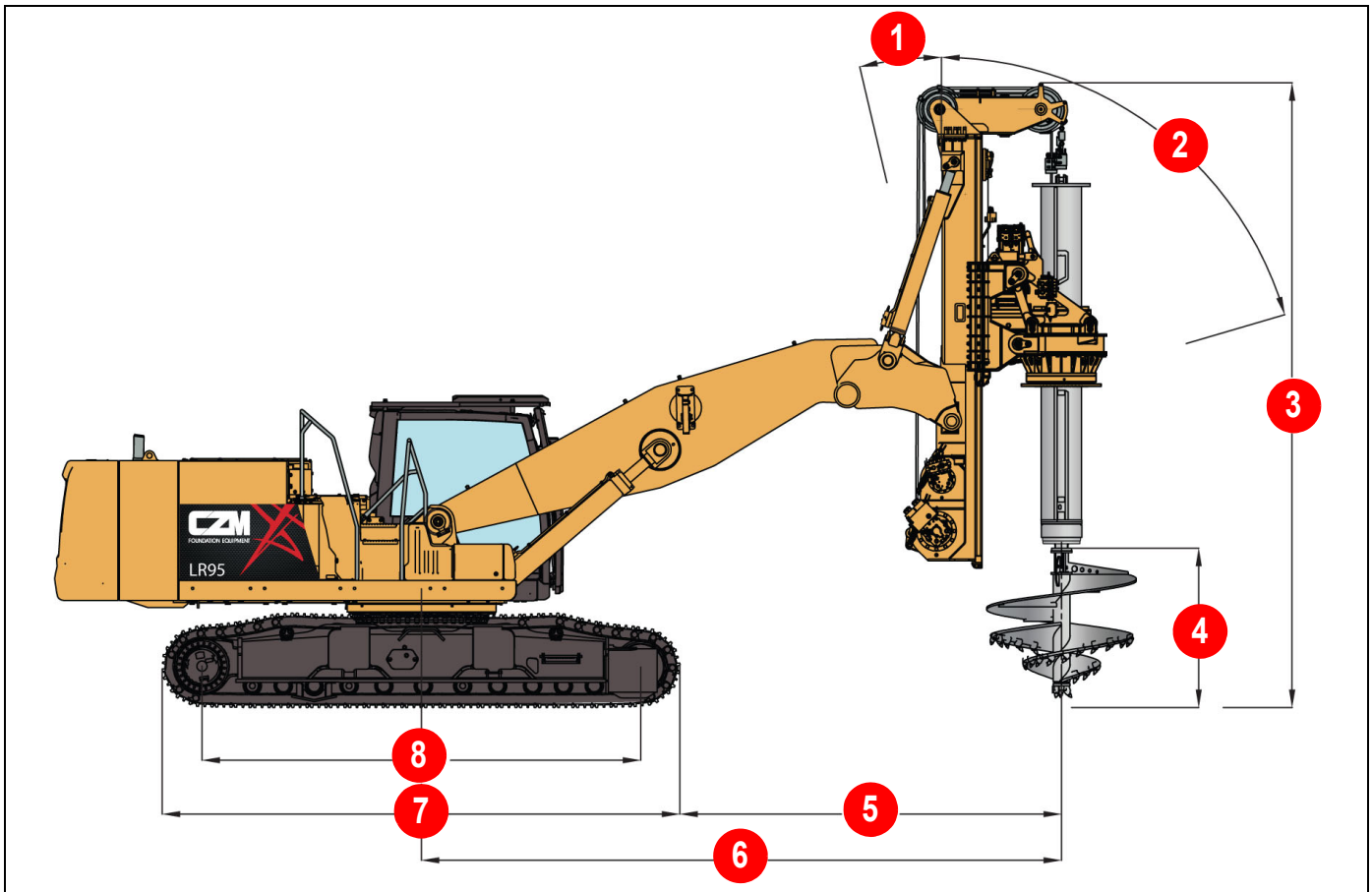

0001915

Figure 5-1

- | | | |
|---------------------------|---------------------------|---------------------------|
| 1) 13° | 4) 5 ft 3 in. (1,600 mm) | 7) 17 ft (5,190 mm) |
| 2) 74° | 5) 12 ft 7 in. (3,830 mm) | 8) 14 ft 5 in. (4,400 mm) |
| 3) 20 ft 5 in. (6,260 mm) | 6) 21 ft (6,420 mm) | |

Transport Position Short Mast

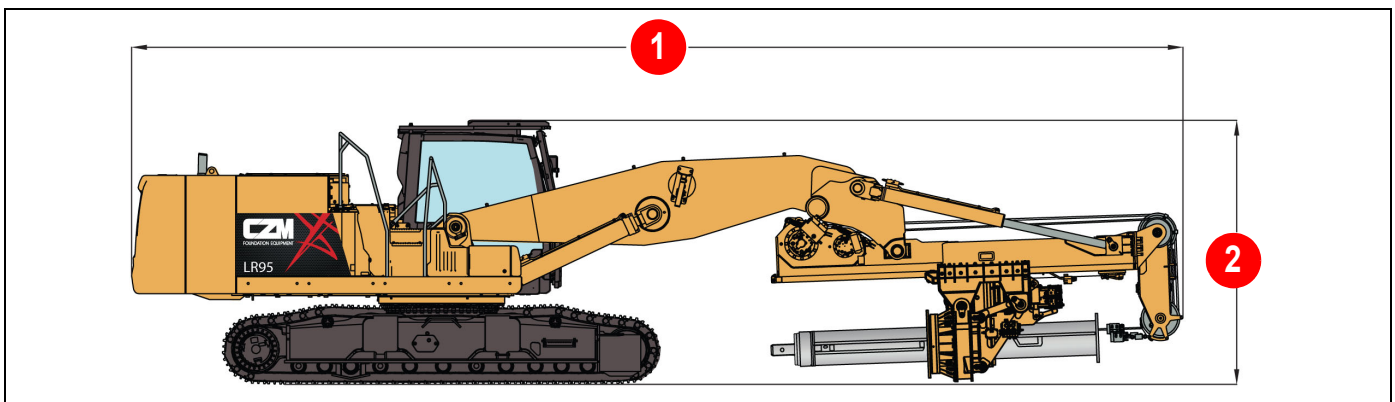

0001913

Figure 5-2

- | | |
|-----------------------------|---------------------------|
| 1) 40 ft 11 in. (12,470 mm) | 2) 10 ft 4 in. (3,160 mm) |
|-----------------------------|---------------------------|

Working Position Long Mast (Boom Up)

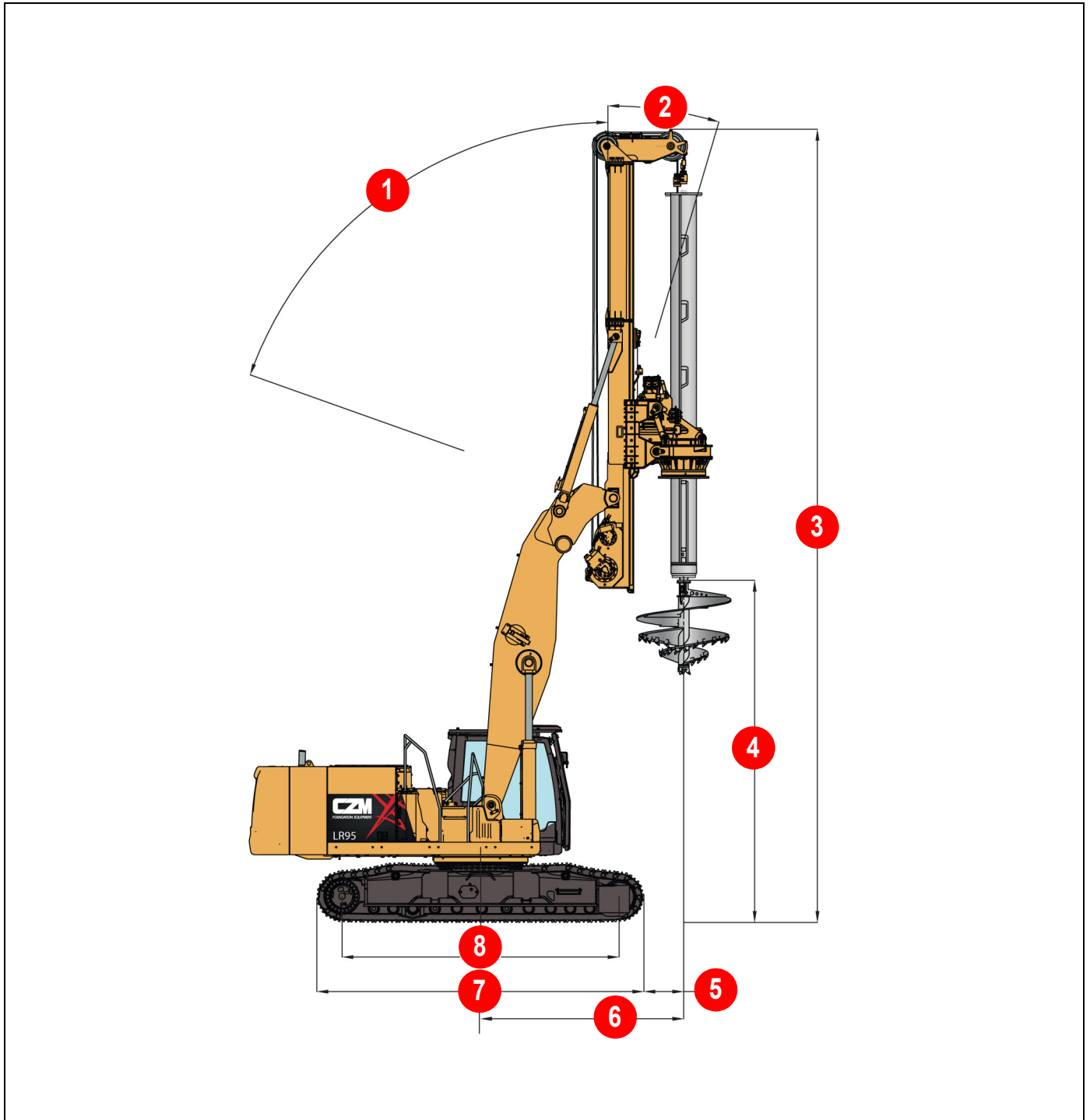

Figure 5-3

0001911

- | | | |
|----------------------------|----------------------------|---------------------------|
| 1) 70° | 4) 17 ft 10 in. (5,440 mm) | 7) 17 ft (5,190 mm) |
| 2) 15° | 5) 2 ft 1 in. (630 mm) | 8) 14 ft 5 in. (4,400 mm) |
| 3) 41 ft 4 in. (12,600 mm) | 6) 10 ft 9 in. (3,230 mm) | |

GENERAL DIMENSIONS

Working Position Long Mast (Boom Forward)

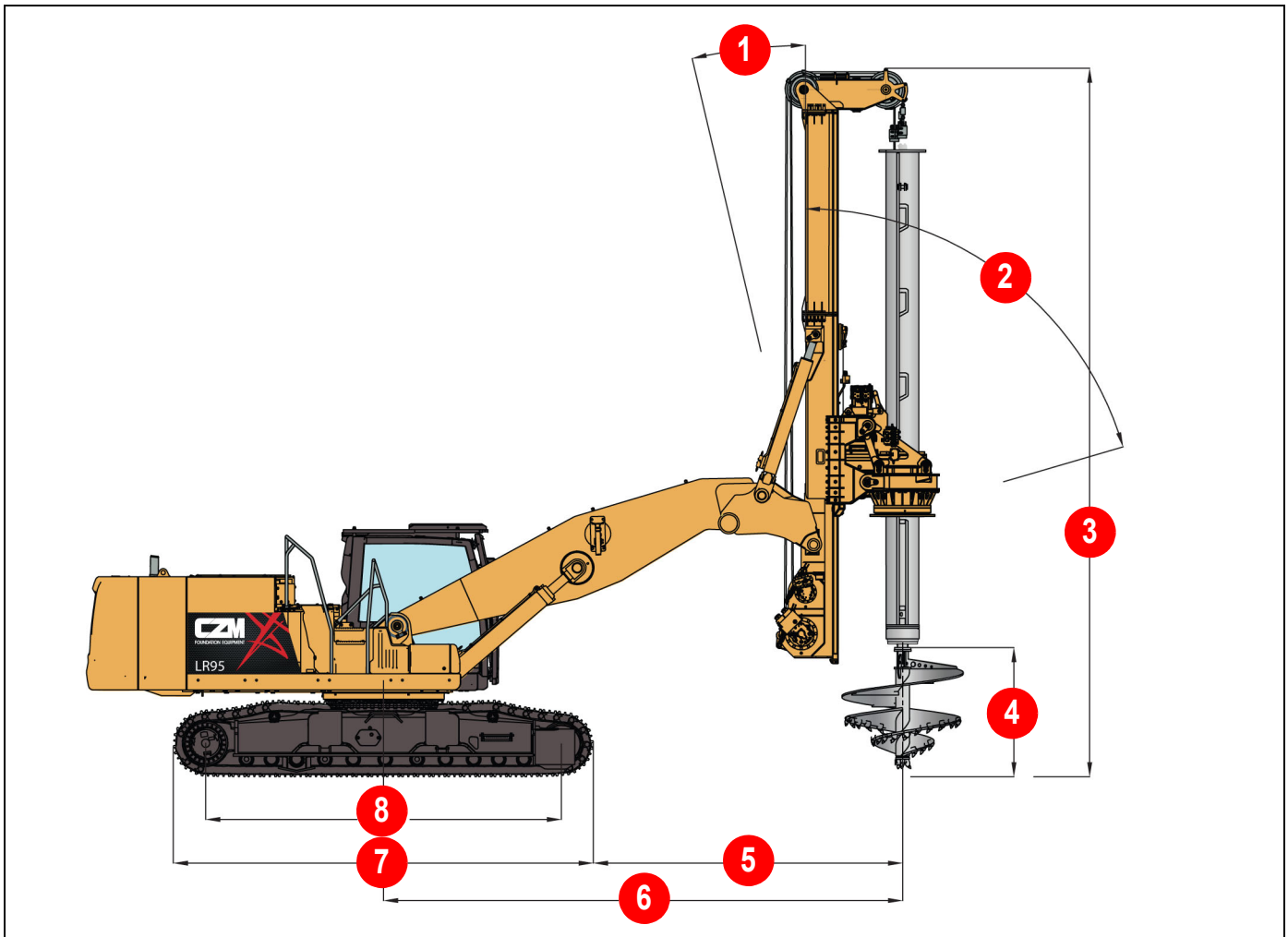
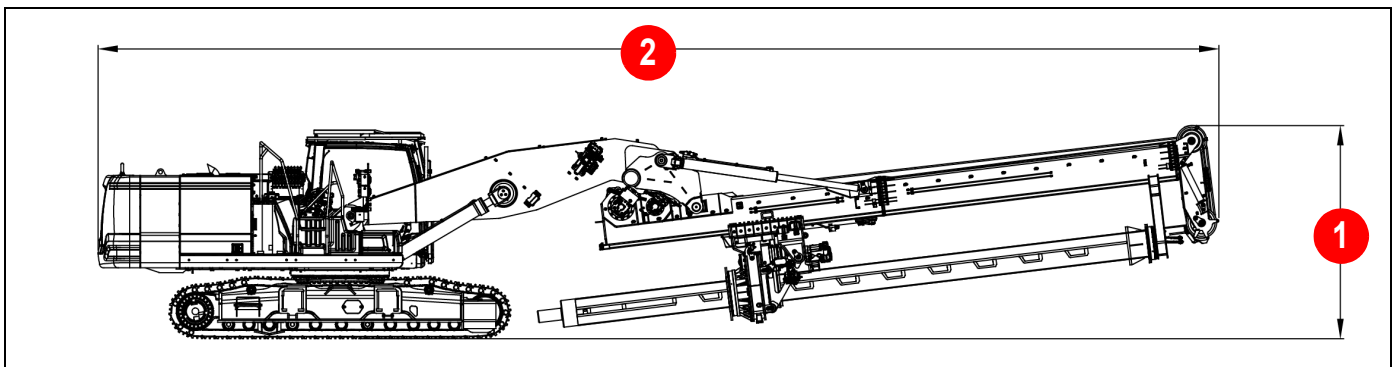

Figure 5-4

0001912

- | | | |
|---------------------------|---------------------------|---------------------------|
| 1) 13° | 4) 5ft 3 in. (1,600 mm) | 7) 17 ft (5,190 mm) |
| 2) 74° | 5) 12 ft 7 in. (3,830 mm) | 8) 14 ft 5 in. (4,400 mm) |
| 3) 28 ft 9 in. (8,760 mm) | 6) 21 ft (6,420 mm) | |

Transport Position Long Mast



- | | |
|--------------------------|----------------------------|
| 1) 9 ft 6 in. (2,900 mm) | 2) 55 ft 9 in. (17,000 mm) |
|--------------------------|----------------------------|

0001929

Mast Tilting

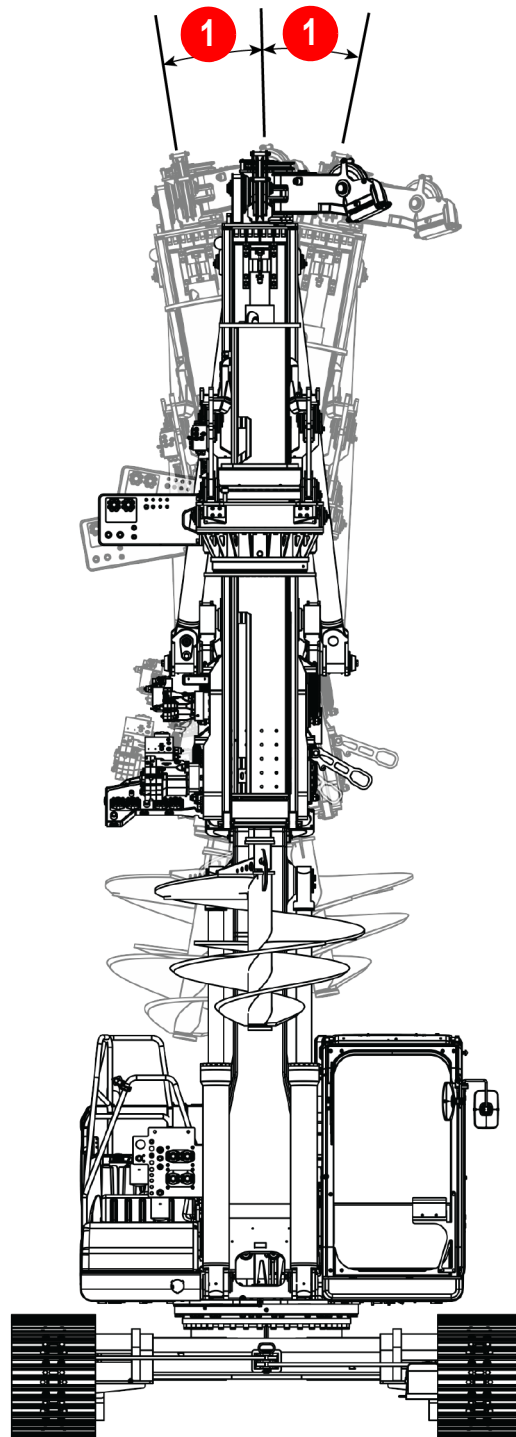

1) Left/Right 12° /12°

0000961

GENERAL DIMENSIONS

Page Intentionally Left Blank

Chapter 6

Controls

Controls Overview

This section provides information regarding the function and location of the machine controls. The LR95 drilling rig utilizes a combination of hydraulic, electro-hydraulic, and electrical controls to provide the operator with ergonomic and accurate machine control. Designed for ease of use and high efficiency, these controls provide for reliable daily operation.

⚠ DANGER

Do not start, test, or operate the machine without first having carefully consulted this manual and being completely familiar with the controls. Both the correct and unauthorized methods of operation must be understood to avoid death, serious injury, and equipment damage. The safety of the operator and people in the vicinity of the machine depends on the judgment and prudence of the operator. Therefore the operator of the machine must know the position and function of each control (standard or optional).

Failure to follow these precautions will result in death or serious injury.

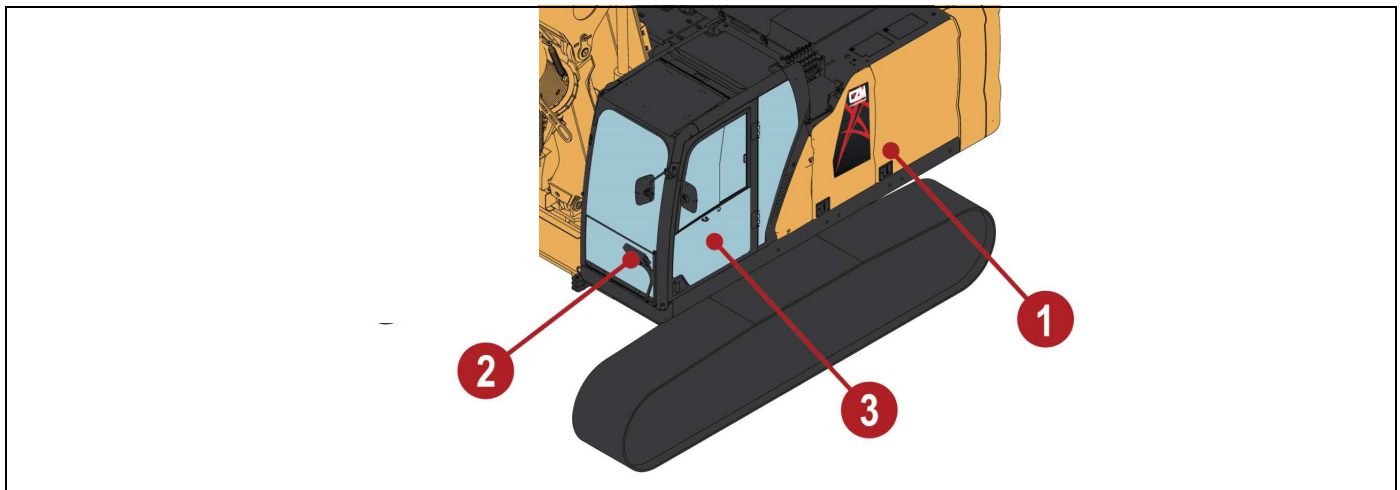

Figure 6-1: Controls Overview

0000781

Item	Description	Page Reference
1	Battery Disconnect Switch	See "Battery Disconnect Switch*" on page 6-2.
2	Pump Gauges	See "Main and Auxiliary Pump Gauges" on page 6-14.
3	Cab Overview	See "Cab Overview" on page 6-3.

CONTROLS

Battery Disconnect Switch*



Figure 6-2: Left Rear Door

The battery disconnect switch is on the left side of the machine behind the rear access door.

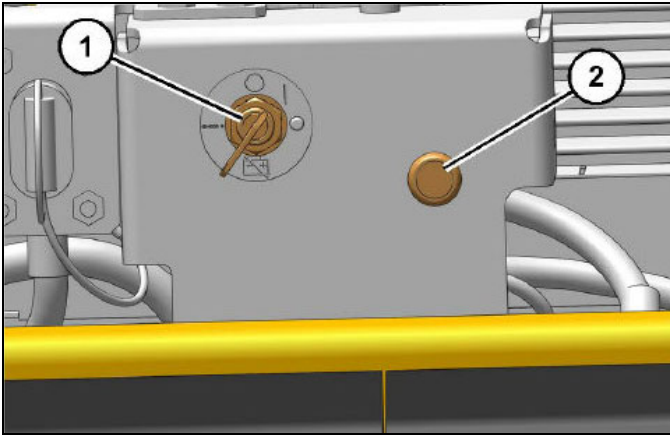

Figure 6-3: Battery Disconnect Switch-Panel

- 1) Battery Disconnect Switch 2) DEF Purge Light

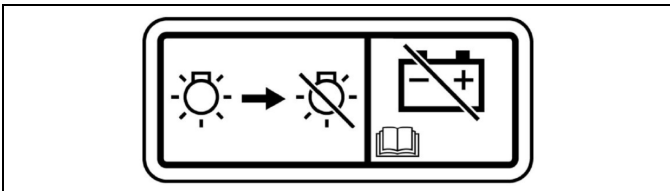

Figure 6-4: DEF Purge Indicator Lamp Decal

NOTICE

Do not turn off the battery disconnect switch until the indicator lamp has turned off. If the switch is turned off when the indicator lamp is illuminated the Diesel Exhaust Fluid (DEF) system will not purge the DEF. If the DEF does not purge, DEF could freeze and damage the pump and lines.

If DEF purge light (2) is illuminated, wait for the light to turn off before turning the disconnect switch to the OFF position. Waiting for the light to turn off allows the DEF system to fully purge the exhaust fluid and prevents damage to engine components.



Battery Disconnect Switch

The battery disconnect switch can be used to disconnect the battery from the machine's electrical system. The key must be inserted into the battery disconnect switch before the battery disconnect switch can be turned.



ON

To activate the electrical system, insert the disconnect switch key and turn the battery disconnect switch clockwise. The battery disconnect switch must be turned to the ON position to enable battery power to start the engine.



OFF

To deactivate the electrical system, turn the battery disconnect switch counterclockwise to the OFF position.

The battery disconnect switch and the engine start switch perform different functions. The entire electrical system is disabled when you turn the battery disconnect switch to the OFF position. The battery remains connected to the electrical system when you turn the engine start switch to the OFF position.

Turn the battery disconnect switch to the OFF position and remove the key when you service the electrical system or any other machine components. If installed with a cover lock, close the cover and install a padlock.

Turn the battery disconnect switch to the OFF position and remove the key if you do not operate the machine for periods of a month or more. Turning off the disconnect switch will prevent the battery from being discharged. A good practice is to use the disconnect switch after you operate the machine. Turning off the disconnect switch will prevent the battery from being discharged. The following problems can cause battery discharge:

- Short circuits
- Current draw via some components
- Vandalism

NOTE: Do not turn off the battery disconnect switch until 5 seconds have elapsed after turning the engine start switch to the OFF position. Do not turn off the battery disconnect switch while the "Lock Security?" screen is displayed on the monitor. See "Parking*" on page 7-48. Both conditions would prevent the Diesel Exhaust Fluid (DEF) system from being purged and could cause the fluid to freeze in the lines.

Cab Overview

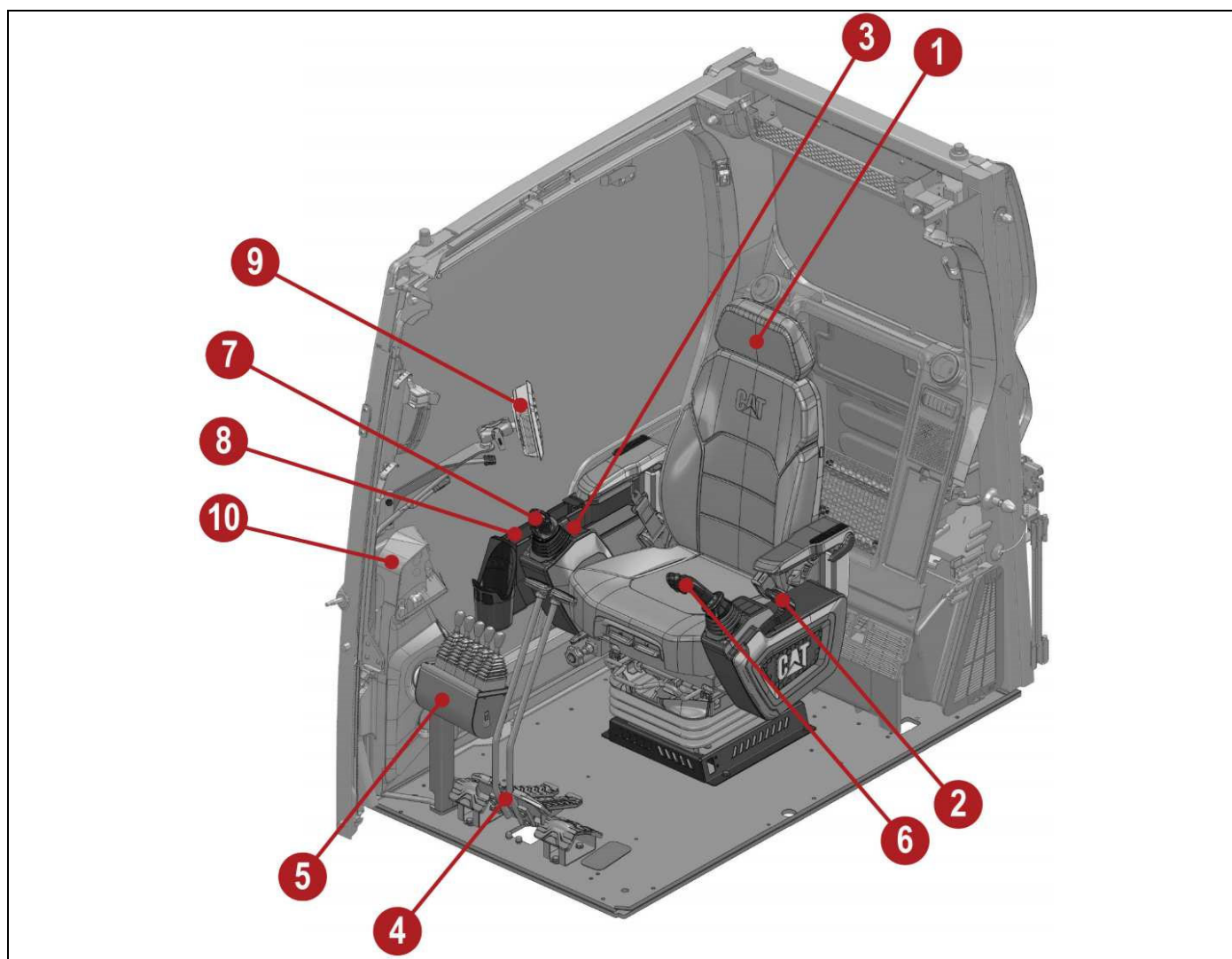

Figure 6-5: Cab Components

0000782

Item	Description	Page Reference	Item	Description	Page Reference
1	Operator Seat	"Operator Seat*" on page 6-4	6	Left Joystick	"Left Joystick" on page 6-10
2	Hydraulic Lockout Control	"Hydraulic Lockout Control*" on page 6-7	7	Right Joystick	"Right Joystick" on page 6-11
3	Engine Start Switch	"Engine Start Switch*" on page 6-7	8	Right Side Switch Panel	"Battery Disconnect Switch*" on page 6-2
4	Travel Controls	"Travel Controls" on page 6-8	9	CZM Monitor	"CZM Monitor" on page 6-14
5	Function Levers	"Function Levers" on page 6-9	10	CAT® Monitoring System	"CAT® Monitoring System*" on page 6-29

CONTROLS

Operator Seat*

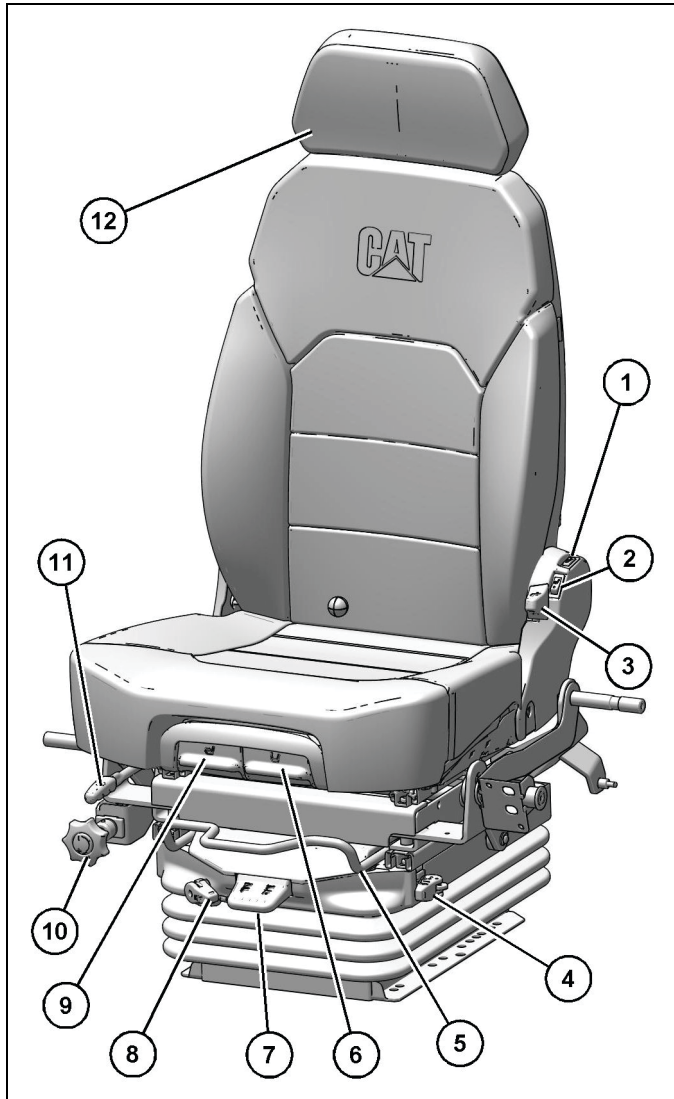

g06251562

Figure 6-6: Operator Premium Level Seat

- 1) Seat heater switch
- 2) Cooling switch
- 3) Adjustment lever for reclining the seat
- 4) Fore/Aft isolator activate/deactivate lever (if equipped)
- 5) Seat and console fore and aft lever
- 6) Seat cushion angle adjuster
- 7) Seat height adjustment
- 8) Adjustable damper
- 9) Seat cushion fore and aft adjuster
- 10) Console height adjustment
- 11) Seat fore and aft adjuster
- 12) Headrest

Adjustment and Operation

Seat heater switch (1) is a three-position switch:

- The middle position of the switch is off.
- Press the top position of the switch for low heat.
- Press the bottom of the switch for high heat.

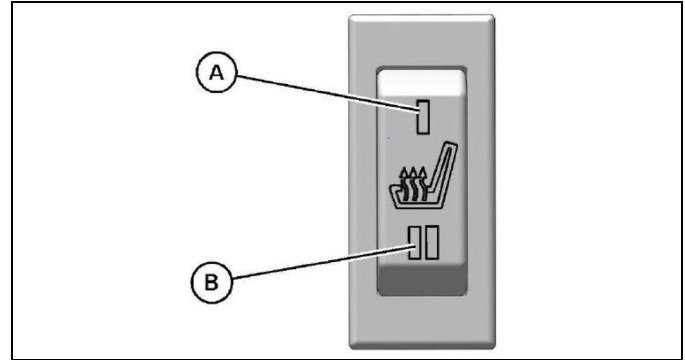

g06251600

Figure 6-7: Seat Heater Switch

A) Low heat

B) High heat

⚠ WARNING

Heat-induced burns can occur when some people use a seat heater. Do not use the seat heater if you have a reduced ability to sense temperature changes, a reduced ability to feel pain, or have sensitive skin. Failure to follow this caution may result in serious or minor injury.

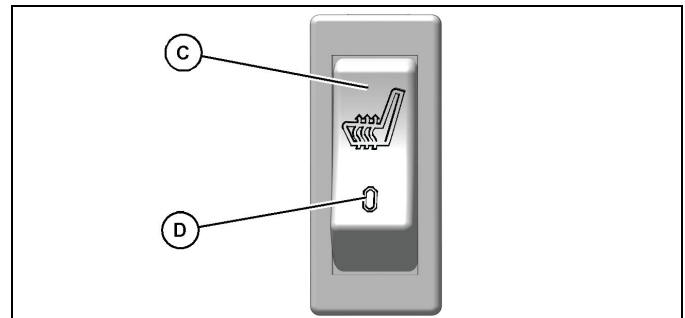

g06251623

Figure 6-8

C) Cooling on

D) Cooling off

To cool the seat, press the top of cooling switch (2). Press the bottom of the switch to turn the cooling off.

Pull up lever (3) to change the angle of the backrest. With the backrest in the desired position, release the lever. Push in adjuster (9) to adjust the fore/aft position of the seat cushion.

Pull lever (5) to adjust the seat and the console forward and backward.

If equipped, fore/aft isolator activate/deactivate lever (4) allows the operator to lock the seat and console or allow the seat and console to float with the movement of the machine. With the adjuster pointing to the front of the machine, the console is locked. Rotate the lever to the rear to unlock the console and allow it to float.

Operate seat height adjustment (7) to adjust the seat and the console to the desired height:

- Pull up the lever to raise the height of the seat.
- Push down on the lever to lower the seat.

NOTICE

Do not operate the seat compressor for over a minute or damage can result.

Use adjustable damper (8) to stiffen or loosen the seat suspension.

Use handle (10) to adjust the height of the console. When the lever is pulled forward, a gear is released. The operator can rotate the lever freely. Release the lever to return to the original position.

To adjust the seat forward or backward, pull up lever (11) and hold the lever. Move the seat to the desired position. To lock the seat in the selected position, release the lever.

Push adjuster (6) to adjust the tilt angle of the seat cushion.

The operator can adjust the height of headrest (12). To adjust the headrest:

1. Hold the headrest with both hands.
2. Move the headrest up and down.
3. Release the headrest when the desired position is attained.
4. The headrest will remain in the desired position.

Lumbar Controls

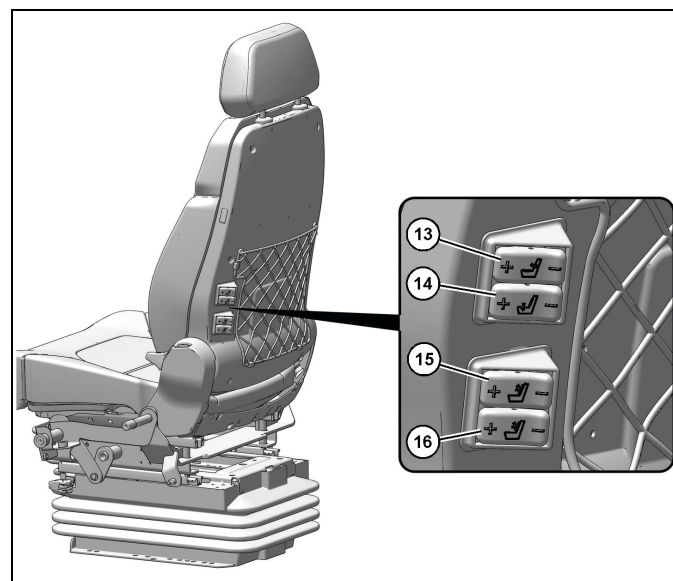

g06251575

Figure 6-9

- | | |
|---------------------------------------|--------------------------|
| 13) Seat back side bolster control | 15) Upper lumbar control |
| 14) Seat cushion side bolster control | 16) Lower lumbar control |

The lumbar controls on the back of the seat back all use two position switches. Press the + symbol to increase lumbar support. Press the - symbol to decrease lumbar support.

CONTROLS

Seat Belt

NOTICE

The seat belt and the instructions for installation of the seat belt meet the SAE J386 and ISO 6683 standards. Always check the condition of the seat belt and the condition of the mounting hardware before you operate the machine.

Fastening The Seat Belt

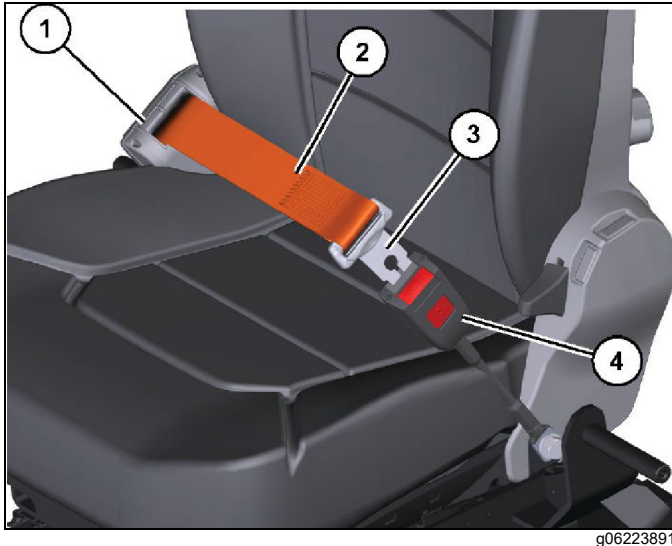

Figure 6-10 Fastening The Seat Belt

1. Pull seat belt (2) out of retractor (1) in a continuous motion.
2. Fasten seat belt catch (3) into the buckle (4). Make sure the seat belt is placed low across the lap of the operator.
3. The retractor will adjust the belt length and the retractor will lock in place. The comfort ride sleeve will allow the operator to have limited movement.

Releasing The Seat Belt



Figure 6-11: Releasing The Seat Belt

1. Push the release button on the buckle to release the seat belt.
2. The seat belt will automatically retract into the retractor.

Extension of the Seat Belt

⚠ WARNING

When using retractable seat belts, do not use seat belt extensions, or personal injury or death can result.

The retractor system may or may not lock up depending on the length of the extension and the size of the person. If the retractor does not lock up, the seat belt will not restrain the person.

Failure to follow this warning may result in death or serious injury.

Longer, non-retractable seat belts and extensions for the non-retractable seat belts are available. Caterpillar requires only non-retractable seat belts to be used with a seat belt extension. Consult your CAT® dealer for longer seat belts and for information on extending the seat belts.

Hydraulic Lockout Control*

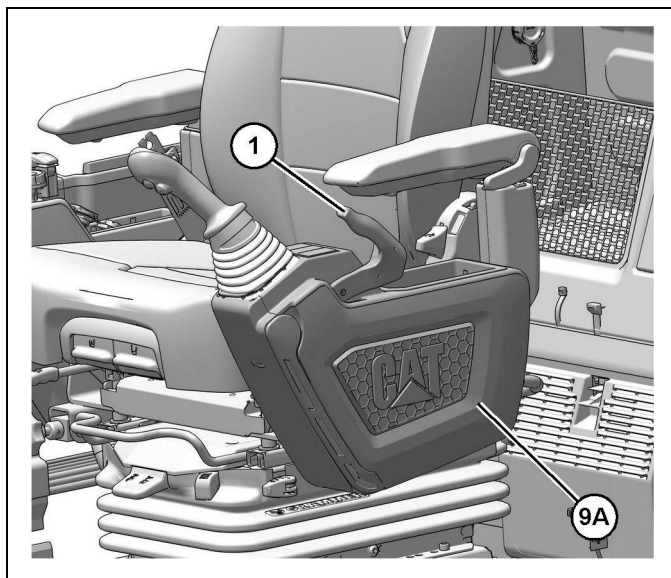

g06226523

Figure 6-12: Hydraulic Lockout Lever

The lever for the hydraulic lockout control is at the left side of the left console.

NOTICE

Make sure the lever for the hydraulic lockout control is in the LOCKED position before attempting to start the engine. If the lever is in the UNLOCKED position, the engine start switch will not function.



Locked – Move the travel levers/pedals and move the joysticks to the HOLD (center) position. Move the lever for the hydraulic lockout control backward to the LOCKED position. All the factory installed hydraulic controls will become inoperable.



Unlocked – Move the lever for the hydraulic lockout control forward to the UNLOCKED position. All the factory installed hydraulic controls will become operable.

Engine Start Switch*

NOTICE

For the correct procedure to start the engine, see “Starting the Machine” on page 7-14.

The engine start switch must be in the ON position and the engine must be running in order to maintain electrical functions and hydraulic functions. This procedure must be followed in order to prevent serious machine damage.

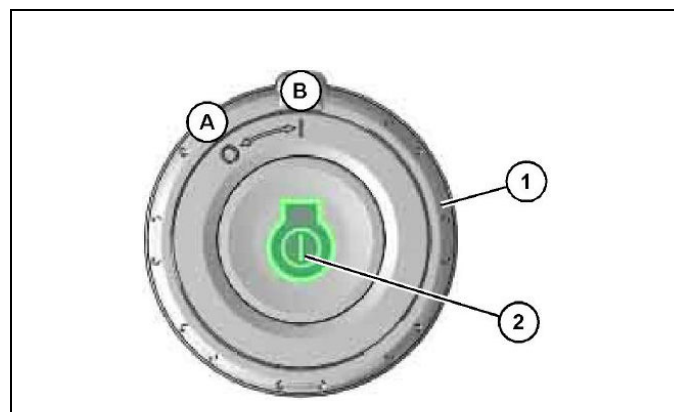

g06180554

Figure 6-13

- | | |
|----------------------|-------|
| 1) Engine start ring | A Off |
| 2) Start button | B On |



OFF – Turn the engine start ring (1) to the OFF position (A) to stop the engine.



ON – To activate the electrical circuits in the cab and enable engine starting, turn the engine start ring (1) clockwise to the ON position (B).



START – To start the engine, enter the code on the monitor. Press start button (2). After the engine starts, release the button.

NOTE: Pressing the start button with the engine on will also turn off the engine.

CONTROLS

Travel Controls

NOTICE

Before moving the machine, check the position of the undercarriage. The normal travel position is with the idler wheels to the front under the cab and the drive sprockets to the rear. When the undercarriage is in the reversed position, the directional controls must be operated in opposite directions.

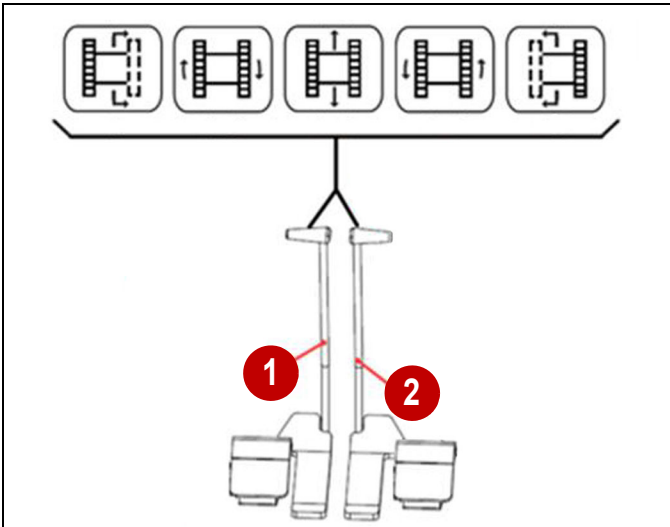

Figure 6-14: Travel Controls

The left travel control lever (1) moves the left crawler forward or backward.

The right travel control lever (2) moves the right crawler forward or backward.

Control	Movement	Description
		Stop - Release the travel levers/pedals to stop the machine. The travel levers/pedals return to the center position and travel brakes are applied.
		Forward Travel

Control	Movement	Description
		Reverse Travel
		Pivot Left Turn (Forward)
		Pivot Left Turn (Reverse)
		Counter Rotate Turn (Left)
		Pivot Right Turn (Forward)
		Pivot Right Turn (Reverse)
		Counter Rotate Turn (Right)

Function Levers

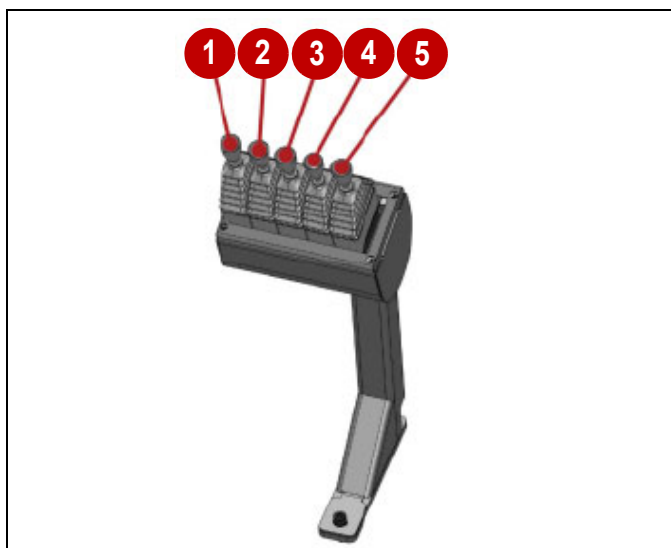

0000458

Figure 6-15: Function Levers

The function levers control the following:

- Lever (1) is not used.
- Lever (2) raises or lowers the auxiliary winch cable.
- Lever (3) raises or lowers the boom.
- Lever (4) extends or retracts the left tilt cylinder. This lever is operated in conjunction with lever (5).
- Lever (5) extends or retracts the right tilt cylinder. This lever is operated in conjunction with lever (4).

Control	Movement	Description
		Not Used
		Auxiliary Winch - Lower
		Auxiliary Winch - Raise
		Boom - Raise
		Boom - Lower
		Mast - Tilt Right
		Mast - Tilt Left

CONTROLS

Joysticks

Left Joystick

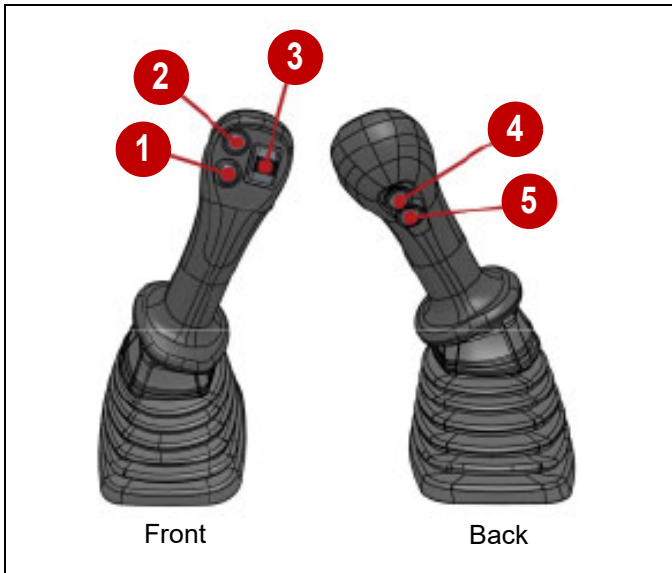

Figure 6-16: Left Joystick Front/Back

0000494

Control	Movement	Description
		Mast Auto Leveling 1
		Base Swing Return to Center 2
		Main Winch Auto-Shift 3
		Horn 4
		Main Winch Low Speed 5

Control	Movement	Description
		Main Winch - Lower
		Main Winch - Raise
		Swing Right
		Swing Left

Right Joystick

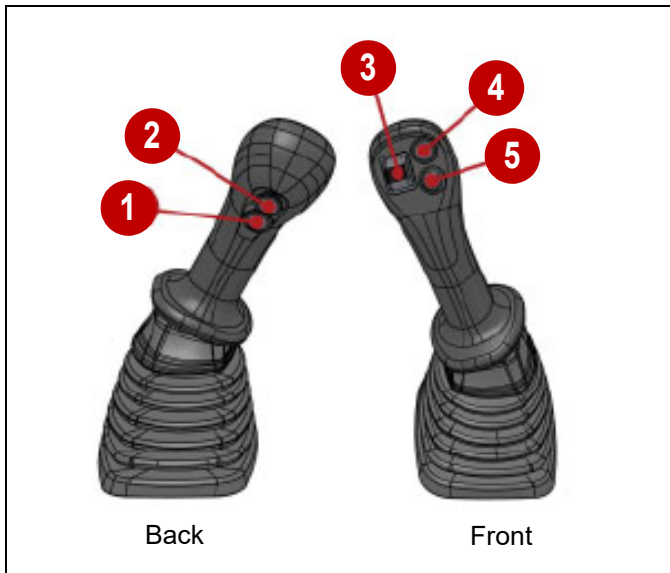

Figure 6-17: Right Joystick Front/Back

0000734

Control	Movement	Description
		Automatic Crowd 1
		Not Used 2
		Rotary Speed 3
		Rotary Spin-Off (Power Shift) 4
		Automatic Drilling 5

Control	Movement	Description
		Crowd Force - Down
		Crowd Force - Up
		Rotary - Counterclockwise
		Rotary - Clockwise

CONTROLS

Right Side Switch Panel*

NOTICE

In addition to the intended functions, the buttons on the switch panel are numbered from 0–9. The numbered buttons can be used to enter values on the monitor screen such as a passcode.

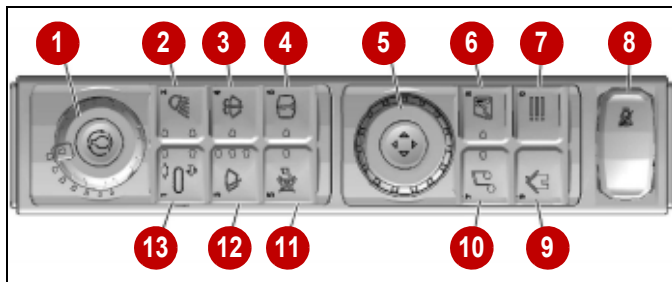

Figure 6-18: Right Side Switch Panel

- | | |
|------------------------------------|------------------------------------|
| 1) Engine speed/power mode control | 8) Travel alarm mute (if equipped) |
| 2) Light switch | 9) Home |
| 3) Window washer | 10) Radio control |
| 4) Operator information | 11) Radio mute switch |
| 5) Jog dial | 12) Window wiper |
| 6) Heating and air conditioning | 13) Travel speed control |
| 7) Next menu | |

The monitor can be navigated by touch screen or the switch panel. Switch panel components can be used to interface with the monitor in the following ways:



Engine Speed/power Mode Control (1) – Engine Speed Control – Turn the dial to control the engine speed (rpm). Select the desired position from the seven available positions:

- Turn the dial counterclockwise to decrease the engine speed (engine rpm).
- Turn the dial clockwise to increase the engine speed (engine rpm).

Power Mode Control – Push in the dial to change the power mode settings. The power mode control allows the operator to choose what power mode to operate the engine. The modes that can be selected are: "ECONOMY", "SMART", and "POWER".

NOTE: The default power mode setting can be set within the monitor. See "Power Mode Setting*" on page 6-52.



Light Switch (2) – Push the switch to turn on the work lights of the cab and base.



Window Washer (3) – Push the switch to activate the window washer.

NOTICE

- If the wiper does not operate with the switch in the ON position, turn the switch off immediately. Check the cause. If the switch remains on, motor failure can result.
- If the washer is used continuously for more than 20 seconds or used when no washer solution comes out, motor failure can result.

While the switch is pressed, the indicator light will come on and washer fluid will spray from the nozzle. The window wiper will also operate while the switch is pressed.

After the switch is released for approximately 3 seconds, the window wiper will stop.



Operator information (4) – Press and hold this button to view the operator information screen.

The indicator light will illuminate when the button is pressed.

Jog dial (5) – The jog dial can be used to select items displayed on the monitor screen. The dial can be rotated 360 degrees. The dial can also be moved left, right, up, and down. The dial can be pushed in to make a selection.



Air Conditioning and Heating (6) – Press this button to bring up the air conditioning and heating menu. The indicator light will illuminate when the heating and cooling system is active.

The jog dial (5) can be used to make selections. If equipped with a touch screen, the selections can be made by touching the monitor. See "Air Conditioning and Heating Control*" on page 6-38.



Next Menu (7) – Press the next menu button to access the next higher menu. If there is not a menu above the current screen being viewed, the button will not do anything. See "CAT® Monitoring System*" on page 6-29.



Travel Alarm Mute Switch (8) – If equipped, press the travel alarm mute switch to mute the travel alarm.

NOTICE

The travel alarm will not sound when the travel levers or the travel pedals are activated.



Home (9) – Press the home key to return to the default display at any time. See “CAT® Monitoring System*” on page 6-29.



Radio Control (10) – Press this button to display the radio controls on the monitor. The indicator light on the button will illuminate when the radio is turned on. Use jog dial (5) to make selections. If equipped with a touch screen display, touch the icons on the screens to make a selection. See “Radio Operation*” on page 6-37.



Radio Mute button (11) – Press the radio mute switch to mute the radio. The indicator light will illuminate when the mute is activated. Press the button again to unmute the radio.



Window Wiper (12) – Push the switch to activate the window wiper.

Whenever the switch is depressed, the mode of the window wiper will change according to the indicator light that is illuminated.

6 Second Delay - When the window wiper switch is depressed one time, the first indicator light will turn on. The window wiper will operate intermittently at six-second intervals.

3 Second Delay - When the window wiper switch is depressed two times, the second indicator light will turn on. The window wiper will operate intermittently at three-second intervals.

Continuous Operation - When the window wiper switch is depressed three times, the first indicator light and the second indicator light will turn on. The window wiper will operate continuously.

OFF - When the window wiper switch is depressed four times, the indicator lights will turn off. The window wiper stops.



Travel Speed Control (13) – If equipped, Press the travel speed control switch to select automatic travel speed or low travel speed.

NOTICE

Continuous driving at high speed should be limited to 2 hours. If you need to continue driving at high speed for more than 2 hours, stop the machine for 10 minutes. This process will cool down the travel drives before you resume driving.

When the engine start switch is on, the travel speed control switch is always set at the LOW-SPEED position. Whenever the travel speed control switch is pressed, the travel speed changes.

The indicator lights illuminate to show which speed selection is active.



LOW SPEED - Select the LOW-SPEED position if you travel on rough surfaces or on soft surfaces or if you require a great drawbar pull. Also, select the LOW-SPEED position if you are loading a machine onto a trailer or you are unloading a machine from a trailer.



AUTOMATIC - If you travel on a hard, level surface at a fast speed, select the AUTO position.

⚠ WARNING

Do not change the setting of the travel speed control switch while you travel. Machine stability may be adversely affected. Failure to follow this warning could result in death or serious injury.

Main and Auxiliary Pump Gauges

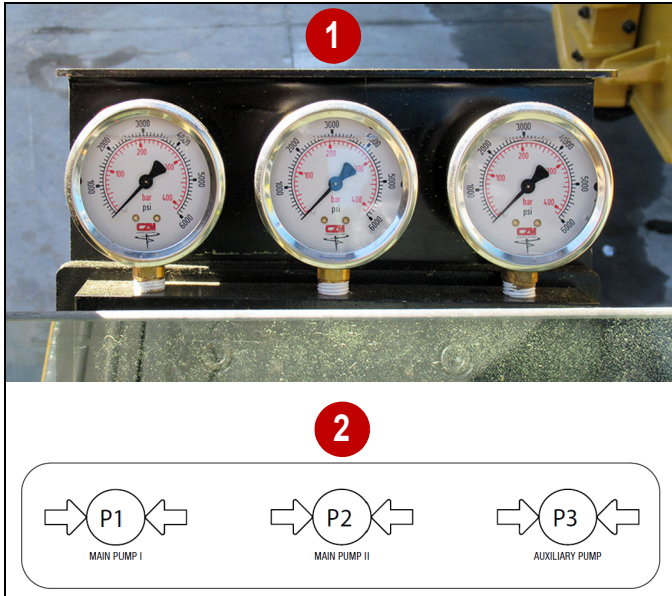

0000358 and 0000358

Figure 6-19: Pump Pressure Gauges

The main and auxiliary pump gauges (1) are located outside the front windshield of the cab, to the left of the operator. The pressure gauges display system hydraulic oil operating pressure of hydraulic pumps P1, P2, and P3 (2).

CZM Monitor

The LR95 drilling rig monitors parameters of the equipment operation. The monitor displays active drilling rig sensor status. It gives the operator control over aspects of the drilling rig from the cab. The monitor is at the front of the cab, to the right of the operator.

Initial Screen

The monitor turns on automatically when the engine start switch is in the ON position. The initial screen is shown in the figure below.

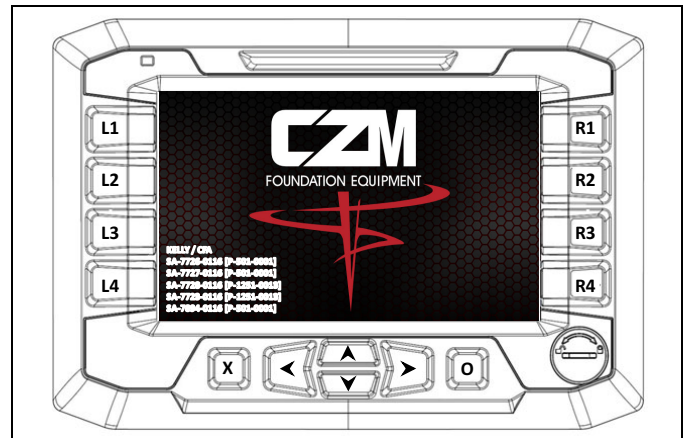

0000341

Figure 6-20: Initial Screen

Home Screen

The Home Screen is displayed during the base machine start-up, and after the system performs its initial system scan. On this screen, the operator can access basic information about equipment, and diagnose or bypass any safety system identified by their sensors.

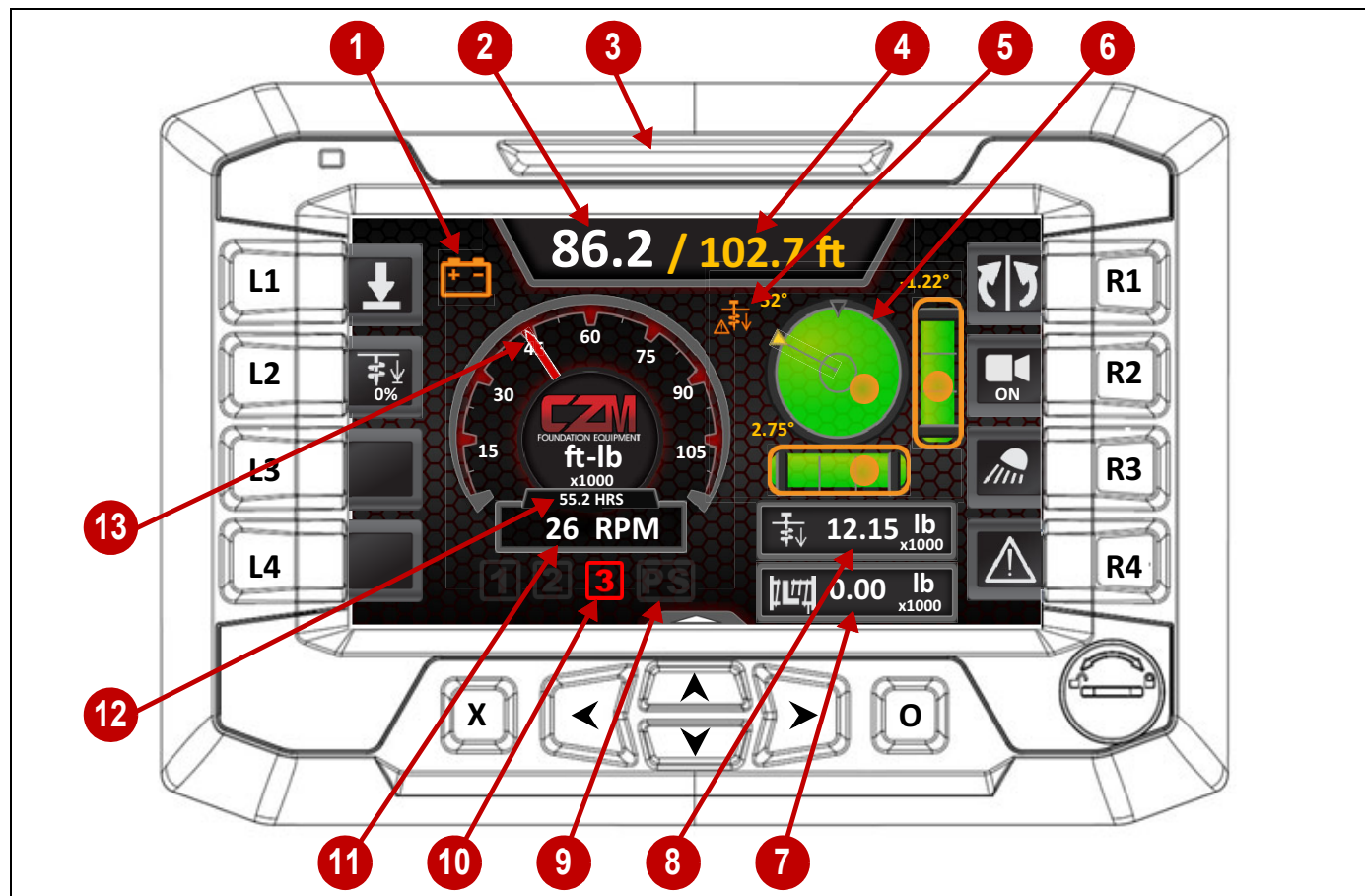

Figure 6-21: Home Screen Display

0000342

- | | | | |
|--------------------------------|-------------------------|---------------------------|---------------------------|
| 1) Battery Icon | 5) Over-Crowd Warning | 9) Power Shift Indicator | 13) Rotary Torque Display |
| 2) Current Drill Depth Display | 6) Mast Level Indicator | 10) Rotary Gear Indicator | |
| 3) Fault (LED) Status Bar | 7) Main Winch Force | 11) Rotary RPM Display | |
| 4) Maximum Drill Depth | 8) Crowd Force | 12) Hour Meter Display | |

The following are displayed on the monitor home screen:

Battery Icon (1) – The battery icon illuminates when the alternator is not at charging voltage.

Current Drill Operation Depth Indicator (2) – Displays the current depth of the kelly bar.

Fault status – Light Emitting Diode (LED) Bar (3) – The LED bar indicates if any fault are active:

- Gray: No fault active. The system is ready for operation.
- Red: The system scan failed. Operation is disabled.

- Orange (blinking): A fault is active.

Maximum Drill Operation Depth Indicator (4) – Displays the maximum depth of the kelly bar.

Over-Crowd Warning (5) – Displays when an over-crowd condition occurs.

Mast Level Indicator (6) – Displays the current angle of the mast on the X and Y axis direction.

CONTROLS

Main Winch Force Indicator (7) – Displays the main winch force during operation. Also displays the crowd winch speed:

- (H) for high speed
- (L) for low speed

Crowd Force Indicator (8) – Displays the crowd force during operation.

Power Shift Indicator (9) – Displays when the power shift is activated.

Rotary Gear Indicator (10) – Displays the operating rotary gear position.

Rotary RPM Indicator (11) – Displays the rotary rpm during operation.

Hour Meter (12) – The hour meter records system hours.

Rotary Torque Indicator (13) – Displays the rotary torque during operation.

Home Screen Switch Functions

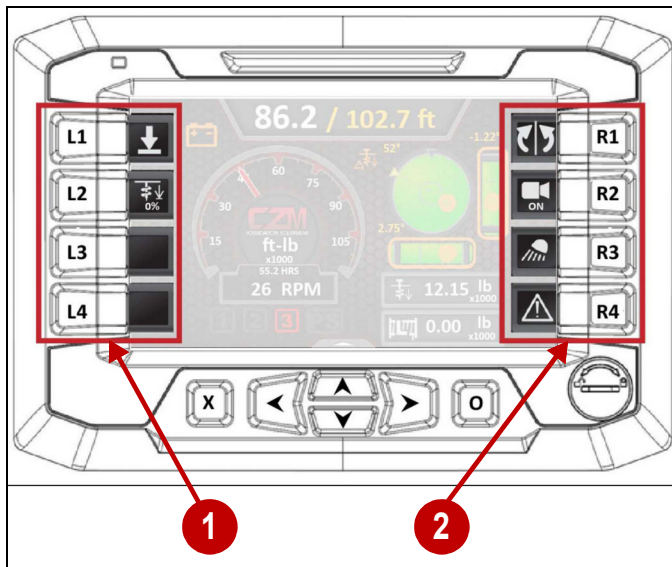

Figure 6-22: Home Screen Switches

Switches L1–L4 (1) are located on the left side of the monitor.

Switches R1–R4 (2) are located on the right side of the monitor.

L1 – Zero the Depth Switch

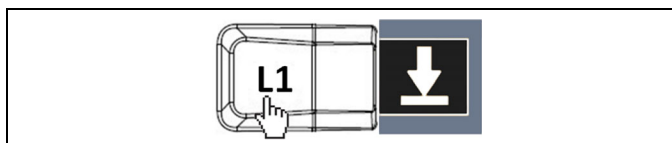

Figure 6-23

Press and hold the L1 zero depth switch to zero the depth.

L2 – Auto Crowd Switch

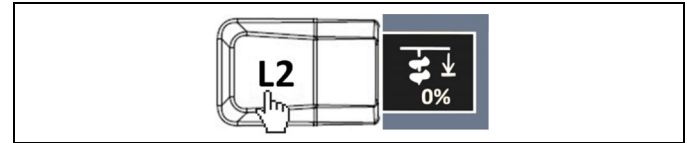

Figure 6-24

Press and hold the L2 switch to activate Auto Crowd and display the drilling progress.

R1 – Return to Center Switch

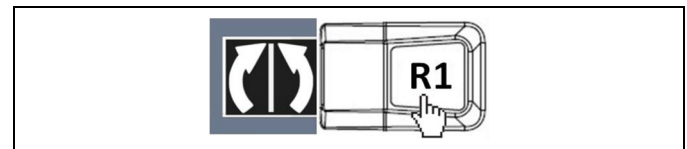

Figure 6-25

Press and hold the R1 switch to set the current swing location as the hole center.

R2 – Swing Camera Switch

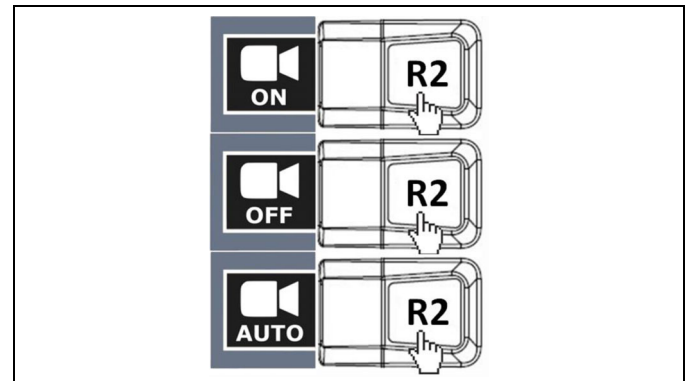
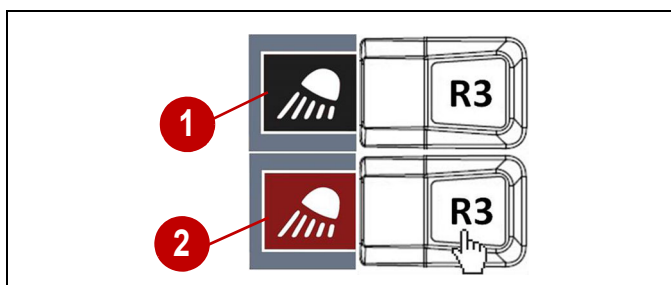

Figure 6-26

Press the R2 switch to set the desired camera mode function:

- ON – The swing camera view is on.
- OFF – The swing camera view is off.
- AUTO – The swing camera screen is automatically displayed during swinging operations.

R3 – Mast Lights Switch



0000125

Figure 6-27

State (1) – The mast lights are off and the mast light switch icon is off.

State (2) – The mast lights are on and the mast light switch icon is illuminated.

R4 – Faults Page Switch

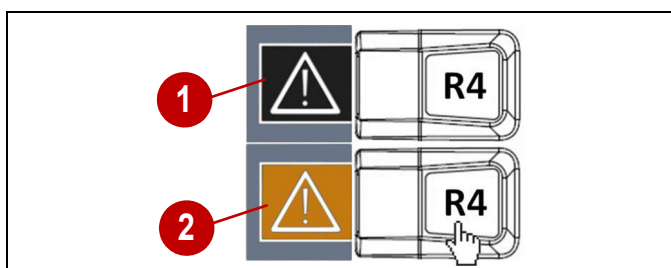

0000126

Figure 6-28

State (1) – No active faults present.

State (2) (Flashing icon) – An active fault is present. Press the switch to display the active faults screens. See “Active Faults Screens” on page 6-28.

CONTROLS

Home Screen Machine Settings

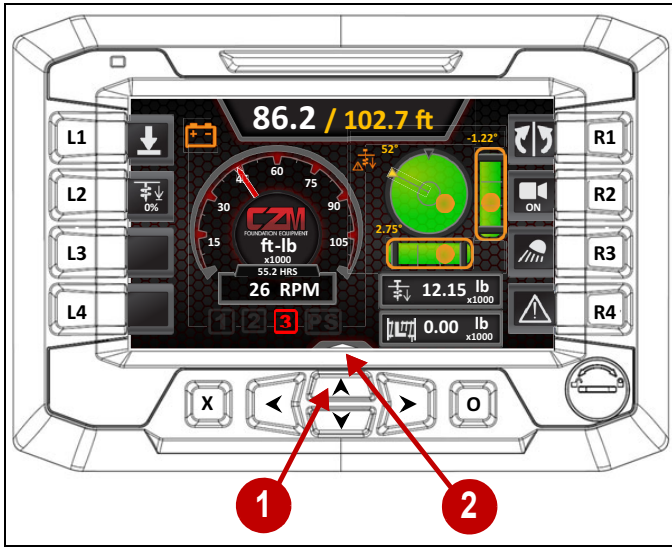

Figure 6-29: Home Screen

From the Home Screen, press the up arrow button (1), or the small up arrow (above the up arrow button) on the screen (2), to display the machine settings screen options.

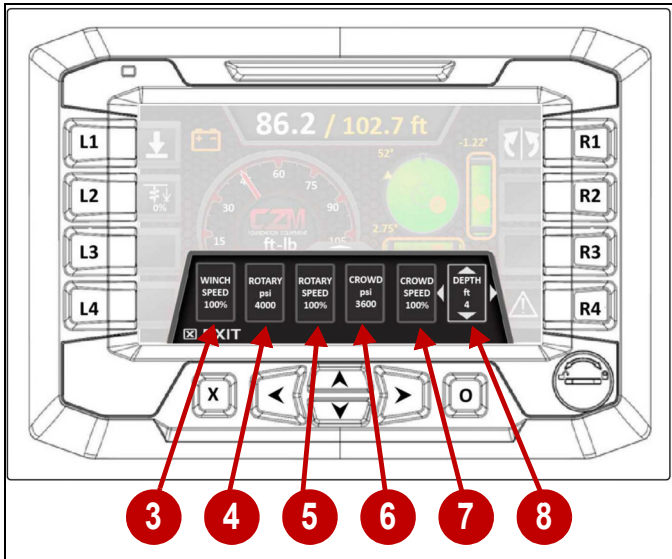

Figure 6-30: Machine Settings Display

Press the left arrow button or right arrow button, or touch the icon along the bottom of the screen, to highlight a function.

NOTE: The selected function has a white outline (as shown around the DEPTH setting) with an up, down, left, and right arrow to select functions.

Once a function is selected (highlighted), press the up arrow button or down arrow button to change the setting.

A setting may also be changed by touching the screen on the up arrow icon or down arrow icon next to the white outline.

Press the exit button (X) to exit the setting function.

Machine Setting Options

Main Winch Speed (3) – This parameter sets the maximum main winch speed. As the winch speed is increased, the winch speed increases up to maximum winch speed.

Rotary PSI (4) – This parameter sets the maximum rotary pressure to prevent overcrowding. To avoid stalling the rotary, the crowd force is automatically reduced when the maximum rotary pressure is reached. As the rotary pressure goes down, the crowd force will resume.

Rotary Speed (5) – This parameter sets the maximum rotary speed. The rotary speed can only increase up to the maximum rotary speed.

Crowd PSI (6) – This parameter sets the maximum crowd pressure to prevent overcrowding. Crowd force is automatically reduced to avoid damage to the Kelly bar. As the crowd pressure decreases, the normal crowd force will resume.

Crowd Speed (7) – This parameter sets the maximum crowd speed. As the crowd speed output signal increases, the crowd speed increases to the maximum crowd speed.

Depth (8) – This sets the total depth that will be drilled when the auto crowd is engaged. The depth should be set to match the length of the auger.

Second Screen

On the Second Screen, the operator is able to access basic information on the equipment, and diagnose or bypass any system sensor.

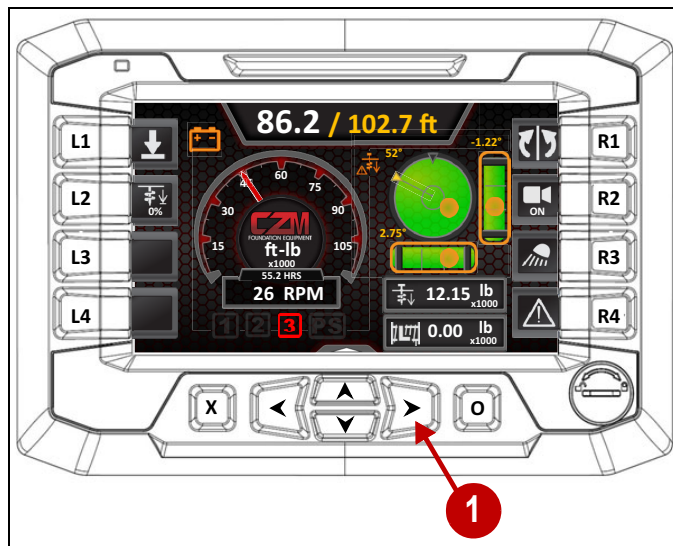

Figure 6-31: Home Screen

From the home screen, press the right arrow button (1) to display the second screen.

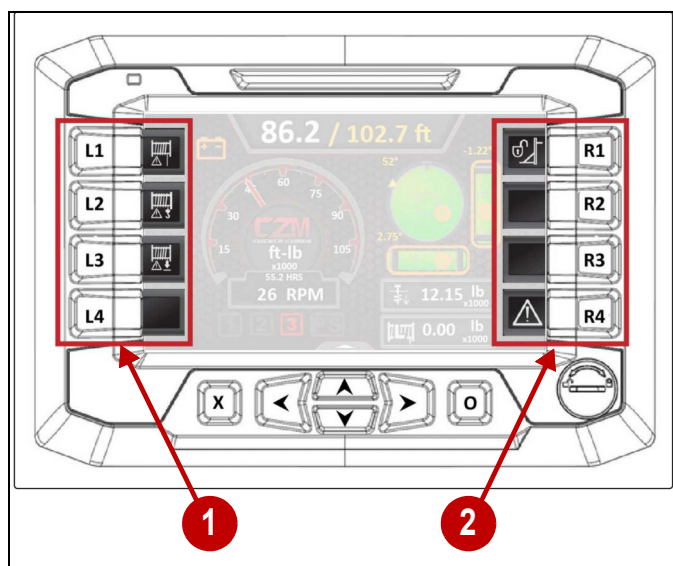

Figure 6-32: Second Screen Switches

On the second screen, the only display changes are to the left (1) and right-side (2) switch functions.

Second Screen Switch Functions

⚠ WARNING

Bypassing the limit switches is very dangerous and can cause accidents with injuries or even death. The bypass of the limit switches must be used only in these cases:

- Emergency, to bring the machine back to safe condition
- Assembly
- Disassembly
- Maintenance

Maximum caution is required during machine operation with safety limit switches in bypass mode.

Failure to follow this warning could result in death or serious injury and could also result in damage to equipment or cause it to operate improperly.

Switch Icon Colors

The displayed colors show the limit switch status.

Outer Ring Color – Indicates if the limit switch has been reached and is engaged.

Outer Ring Color	Indication
	Gray outer ring indicates the limit switch is not engaged.
	Yellow outer ring indicates the limit has been reached and the switch is engaged.

Icon Color – Indicates if the limit switch is in a bypass mode.

Icon Color	Indication
	Black icon indicates the limit switch is not bypassed and is in a normal operating mode.
	Red icon indicates the limit switch in bypass mode.

CONTROLS

L1 – Main Winch Limit and Exclusion Switch

⚠WARNING

Bypassing the limit switches is very dangerous and can cause accidents with injuries or even death. The bypass of the limit switches must be used only in these cases:

- Emergency, to bring the machine back to safe condition
- Assembly
- Disassembly
- Maintenance

Maximum caution is required during machine operation with safety limit switches in bypass mode.

Failure to follow this warning could result in death or serious injury and could also result in damage to equipment or cause it to operate improperly.

NOTE: Monitor function switches can operate in momentary (MOM) and latched (LATCH) modes as selected on the Settings Screen. The default setting is momentary.

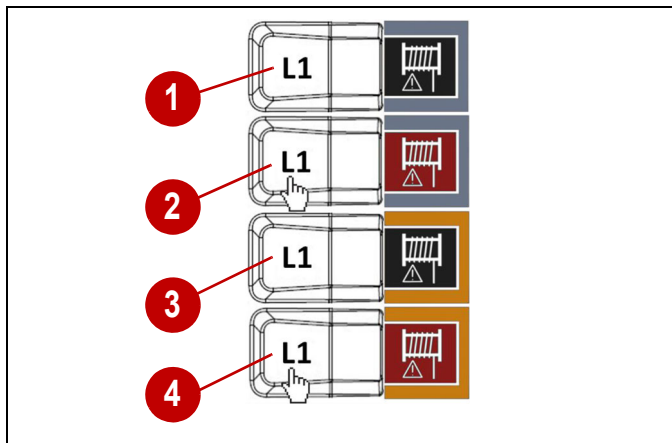

Figure 6-33

The switch icon displays both the main winch limit switch status and if bypass is enabled:

State (1) – The limit switch functions normally, the limit switch is not engaged.

State (2) – The limit switch is in bypass mode, the limit switch is not engaged.

State (3) – The limit switch functions normally and is engaged. The main winch can't be raised.

State (4) – The limit switch has been bypassed and is engaged. The main winch can be raised above its limit.

L2 – Auxiliary Winch Limit and Exclusion Switch

⚠WARNING

Bypassing the limit switches is very dangerous and can cause accidents with injuries or even death. The bypass of the limit switches must be used only in these cases:

- Emergency, to bring the machine back to safe condition
- Assembly
- Disassembly
- Maintenance

Maximum caution is required during machine operation with safety limit switches in bypass mode. Failure to follow this warning could result in death or serious injury and could also result in damage to equipment or cause it to operate improperly.

NOTE: Monitor function switches can operate in momentary (MOM) and latched (LATCH) modes as selected on the Settings Screen. The default setting is momentary.

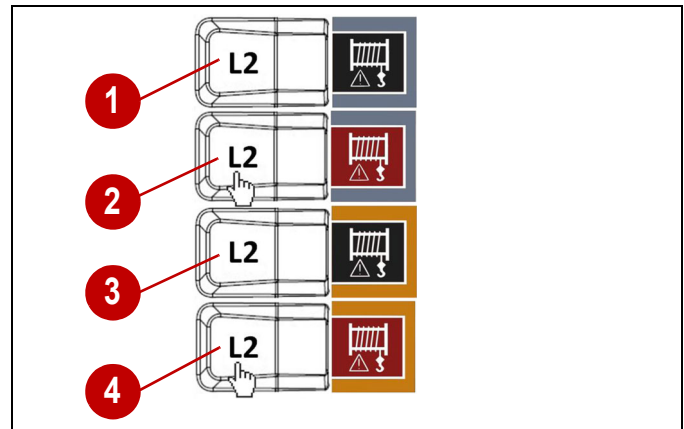

Figure 6-34

The switch icon displays both the auxiliary winch limit switch status and if bypass is enabled:

State (1) – The limit switch functions normally, the limit switch is not engaged.

State (2) – The limit switch is in bypass mode, the limit switch is not engaged.

State (3) – The limit switch functions normally and is engaged. The auxiliary winch can't be raised over the limit position.

State (4) – The limit switch has been bypassed and is engaged. The auxiliary winch can be raised above its limit.

L3 – Main Winch Bottom-Hole Exclusion Switch

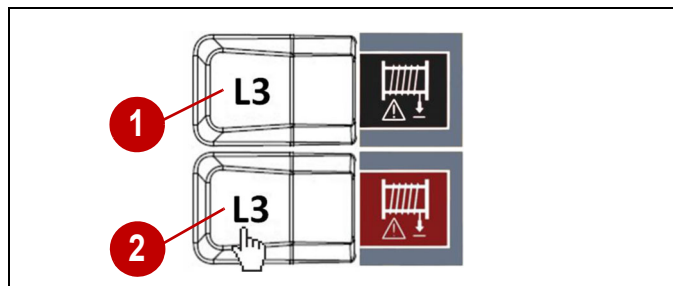

0000129

Figure 6-35

NOTE: Monitor function switches can operate in momentary (MOM) and latched (LATCH) modes as selected on the Settings Screen. The default setting is momentary.

Press the L3 switch to enable or disable the main winch end hole exclusion.

State (1) – The bottom-hole limit switch operates normally and prevents the main winch from lowering when the auger reaches the bottom of the hole.

State (2) – The bottom-hole limit switch is disabled. the main winch can be lowered after the auger has reached the bottom of the hole.

R1 – Mast Lock (If Equipped) Switch

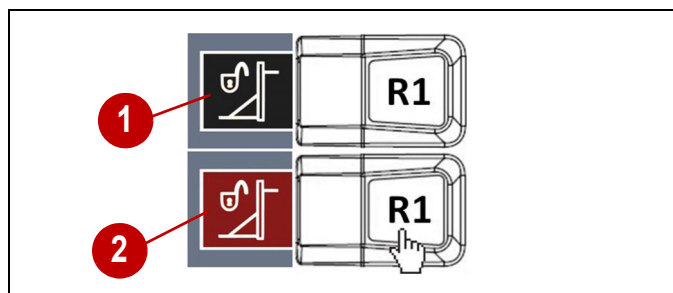

0000131

Figure 6-36

NOTE: Monitor function switches can operate in momentary (MOM) and latched (LATCH) modes as selected on the Settings Screen. The default setting is momentary.

Press the R1 switch to enable or disable the mast lock.

State (1) black – Unlocked

State (2) red – Locked

CONTROLS

Second Screen Machine Setup Functions

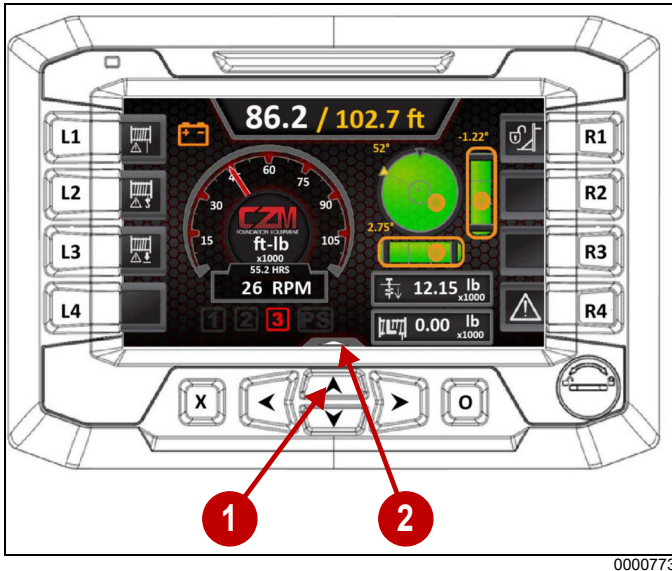

Figure 6-37: Second Screen

On the second screen, press the up arrow button (1) or the up arrow on the monitor screen (2) to display the machine setup functions:

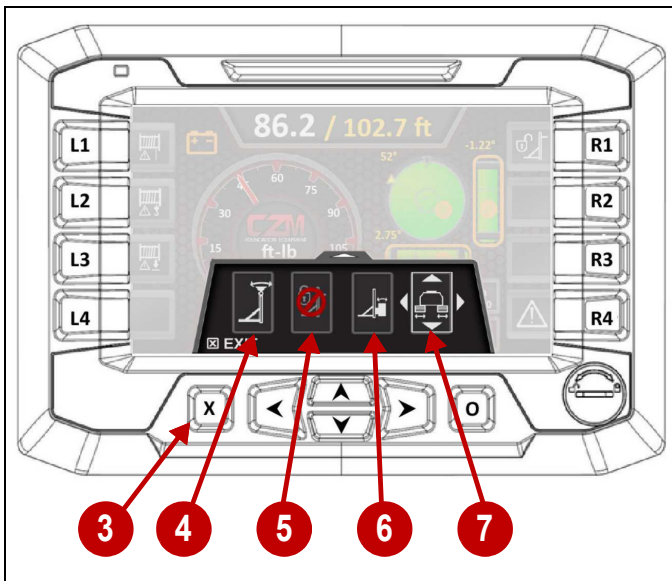

Figure 6-38: Machine Setup Pop-up

Press the left arrow button or right arrow button, or touch the icon along the bottom of the screen to highlight a function.

NOTE: The selected function has a white outline (as shown around the DEPTH setting) with an up, down, left, and right arrow to select functions.

Once a function is selected (highlighted), press the up arrow button or down arrow button to change the setting.

A setting may also be changed by touching the screen on the up arrow icon or down arrow icon next to the white outline.

Press the exit button (3) to exit the setting function.

Machine Setup Options

From the machine setup pop-up, the following machine setup functions can be accessed:

Mast Head Fold (4) – Not Used

A-Frame Detent (5) – Not Used

Rotary Tilt Cylinders (6) – Not Used

Undercarriage Extend/Retract (7) – Use this function to extend the undercarriage tracks for operation or to retract them for transport.

- Working Position. Press the up arrow button or touch the screen on the up arrow icon to extend the undercarriage tracks outward to the working position.
- Transport Position. Press the down arrow button or touch the screen on the down arrow icon to retract the undercarriage tracks to the transport position.
- Press the exit button (3) to exit the setting function.

Third Screen

Accessed from the Second Screen, the Third Screen allows the operator to set operation of:

- MAIN WINCH AUTOSHIFT
- MAIN WINCH DOWNSHIFT
- POWER SHIFT
- ROTARY AUTOSHIFT
- SWING ALARM
- DISPLAY UNITS

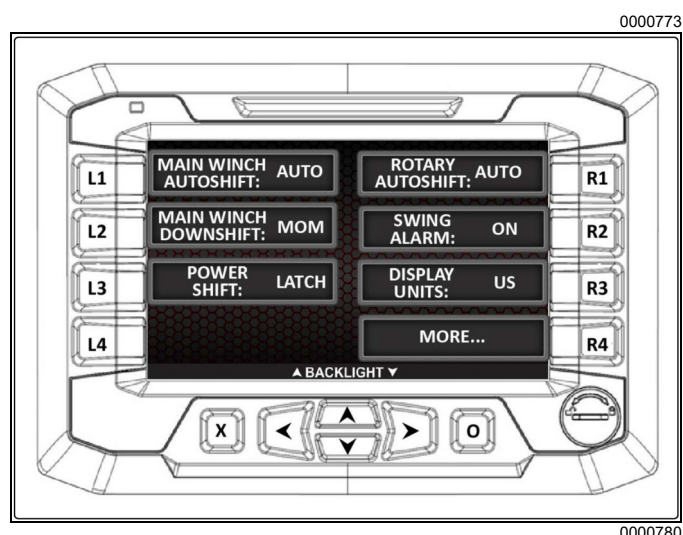

Figure 6-39 Third Screen – Page 1

Access the Third Screen by pressing the right arrow button on the Second Screen.

Third Screen – Page 1 Switch Functions

Main Winch Autoshift (L1) – Press the switch to select AUTO or OFF:

- AUTO – The machine will monitor the main winch pressure and automatically change the gear to high, if a set point is reached, to increase the pull-up force. If the pressure decreases below the low-pressure setpoint, the machine will automatically change the gear to low to increase the speed.
- OFF – Indicates no autoshift

Main Winch Downshift (L2) – Press the L2 switch to select MOM or LATCH.

- Momentary (MOM) downshift requires the operator to press and hold the pushbutton to change the main winch gear from Low to High.
- LATCH operation will alternate between High and Low. When the main winch AUTO mode is selected, the machine will autoshift while operating if needed.

Power Shift (L3) – Press the L3 switch to toggle between and select the MOM, LATCH, or AUTO mode:

- In momentary (MOM) mode, the operator will press and hold the pushbutton to keep power shift engaged for high-speed spin-off.
- In LATCH mode, the operator will press and release the pushbutton to alternate between on or off power shift.
- AUTO mode will automatically engage power shift when the auger is above ground level and the machine swings off to the side at a setpoint degree. Power shift will automatically disengage when the auger returns to center and under ground.

NOTE: The operator can continue to switch between on and off as needed.

Rotary Autoshift (R1) – Press the R1 switch to select ON or OFF. When ON is selected, the machine monitors the pressure for the rotary and automatically downshifts the rotary gear if the pressure reaches a setpoint to increase operating torque and prevent the rotary from stalling. The rotary gear will automatically upshift when the pressure setpoint is reached to increase the rpm as needed.

NOTE: The machine will only upshift to the gear selected by the operator.

Swing Alarm (R2) – Press the R2 switch to select ON or OFF. When ON is selected, the machine will sound an alarm when a swing function is performed.

Display Units (R3) – Press the R3 switch to select US or SI measurement units.

NOTES:

- US displays imperial units. SI displays metric units.
- The measurement units selected will be displayed on all monitor screens.

More Settings (R4) – Press the R4 switch to display the Third Screen - Page 2 settings.

CONTROLS

Third Screen – Page 2

On this screen, the operator can access these functions:

- MAST LEVEL calibration
- CROWD LIMIT OVERRIDE
- CHANGE PASSWORD
- COMPLETE MAINTENANCE screen
- LIMIT SW (switch) OVERRIDES mode
- Additional SETTINGS

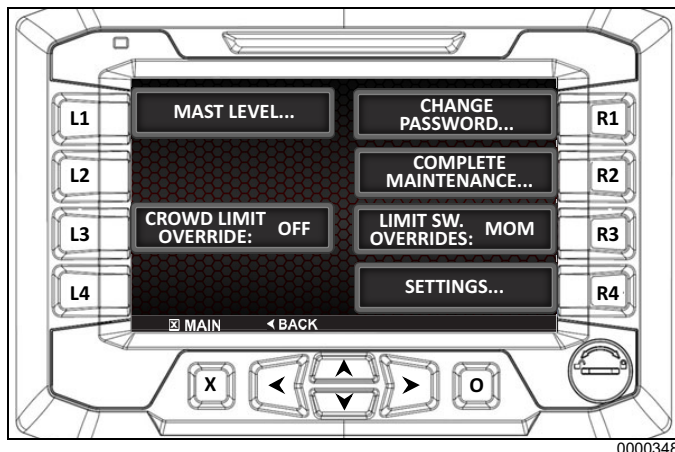

Figure 6-40 Third Screen – Page 2

Press the right arrow button from the Third Screen – Page 1 to access the Page 2 settings or press the R4 MORE) switch on the Page 1 screen. This screen is password protected and is accessed by entering the correct password. The operator can then change selected settings following the on-screen prompts.

Third Screen – Page 2 Switch Functions

Mast Level (L1) – Press the L1 switch to access the Mast Level Calibration screen. See “Mast Level Calibration Screen” on page 6-25.

Crowd Limit Override (L3) – Press the L3 switch to select ON or OFF. When OFF is selected, the machine will control the crowd function based on the angle the base machine is lifted and the maximum torque during operation. This will prevent the operator from overcrowding and stalling the rotary.

CAUTION

When the crowd limit override is set to ON, extra care must be taken to prevent damage by overcrowding the machine and kelly bar.

When ON is selected, the machine automatic crowd limits are disabled. Operating in this mode can result in overcrowding/stalling of the rotary.

Change Password (R1) – Press the R1 switch to access the Change Password screen. See “Change Password Screens” on page 6-25.

Complete Maintenance (R2) – Press the R2 switch to access the Complete Maintenance screen. See “Complete Maintenance Screen” on page 6-26.

Limit Switch Overrides (R3) – Press the R3 switch to select the MOM (momentary) or LATCH (on) mode:

- MOM is the default setting. Press and hold the pushbutton on the Second screen to bypass the main winch limit switch or the auxiliary (Aux) winch limit switch. If a fault occurs with a limit switch, the operator can set the mode to LATCH.
- LATCH allows the operator to continue operation on the current screen, finish the hole in progress, and repair the limit switch fault after completing the operation. When the system is powered off, the limit switch (SW) override will return to the default MOM setting.

Settings (R4) – Press the R4 switch to access the Settings screen. See “Settings Screen” on page 6-27.

Mast Level Calibration Screen

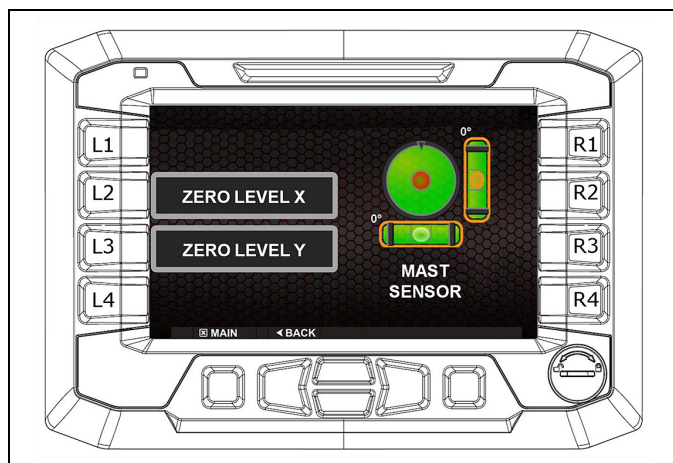

0000135

Figure 6-41: Mast Calibration Display

Press the L1 switch from the Third Screen – Page 2 to access the Mast Level Calibration screen. Leveling the mast on the X and Y axis is adjusted on this screen.

Mast Level Calibration Option Settings

ZERO LEVEL X (L2) – Press the L2 switch to zero the Mast Level X axis.

ZERO LEVEL Y (L3) – Press the L3 switch to zero the Mast Level Y axis.

Change Password Screens

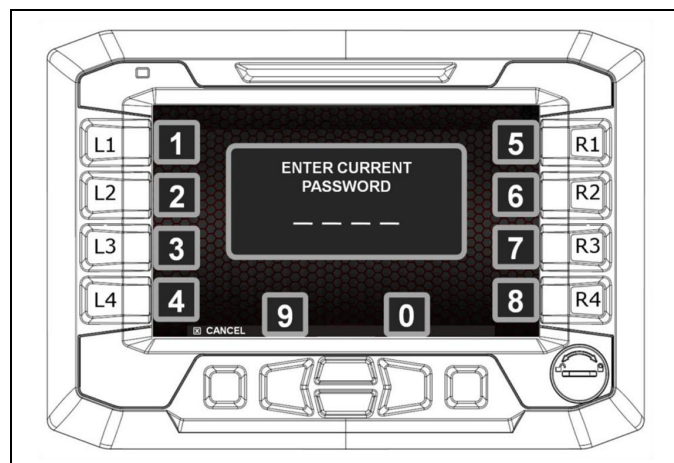

0000136

Figure 6-42: Change Password Screen

Press the R1 switch from the Third Screen – Page 2 to access the Change Password screen. The current correct password must be entered to enter a new password. The password may be changed from the factory password: 0000.

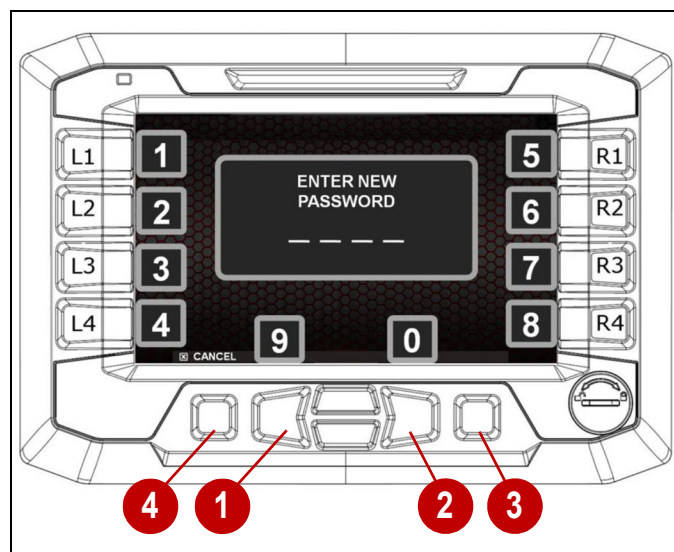

0000137

Figure 6-43

To change the password, perform the following steps:

1. Press the L1–L4 or R1–R5 switches to select numbers 1–8 as shown on the password screen. Press the left arrow button (1) to select the number 9 or the right arrow button (2) to select the number 0. See Figure 6-43 on page 6-25.
2. Press button (3) to accept the selection.
3. Press button (4) to cancel the password change.

CONTROLS

Complete Maintenance Screen

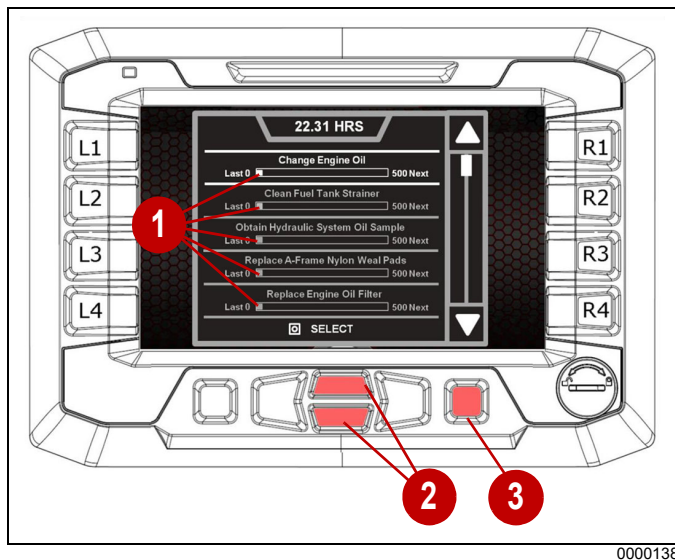

Figure 6-44: Complete Maintenance Screen

Press the R2 switch from the Third Screen - Page 2 to access the Complete Maintenance screen. The operator will be able to access the machine maintenance schedule tasks and monitor when maintenance is required on this screen. Maintenance reset information is also displayed.

A status bar (1) displays the time remaining until the next maintenance task is due. When a maintenance task has been performed and confirmed by the operator, the status bar is reset to the preset interval.

Press the up arrow or down arrow buttons (2) to scroll to the desired maintenance task.

Press the select button (3) to select the desired maintenance task.

After a maintenance task is selected, the following screen is displayed:

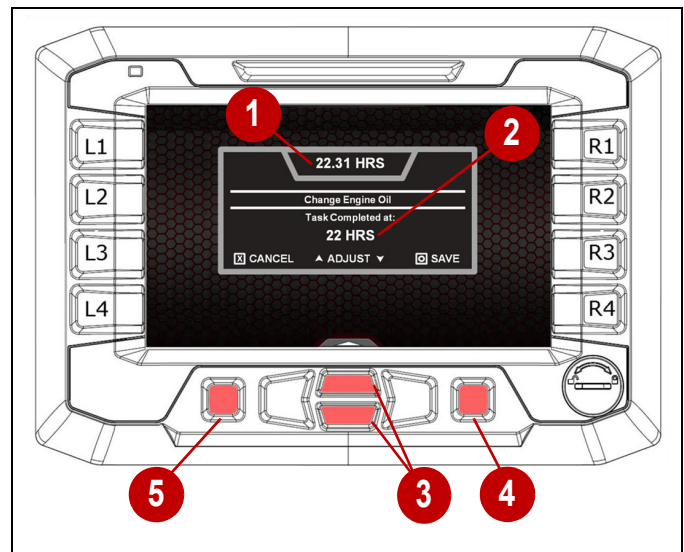

Figure 6-45

The following is displayed on the Complete Maintenance screen – 2:

- Current hour meter reading (1).
- Hour meter reading (2) when the selected maintenance task was completed.

Perform the following steps to confirm and update completed maintenance task times:

1. Press the up arrow or down arrow buttons (3) to adjust the time when the maintenance task was completed.
2. Press the select button (4) to accept the setting.
3. Press the cancel button (5) to cancel the setting change.

Settings Screen

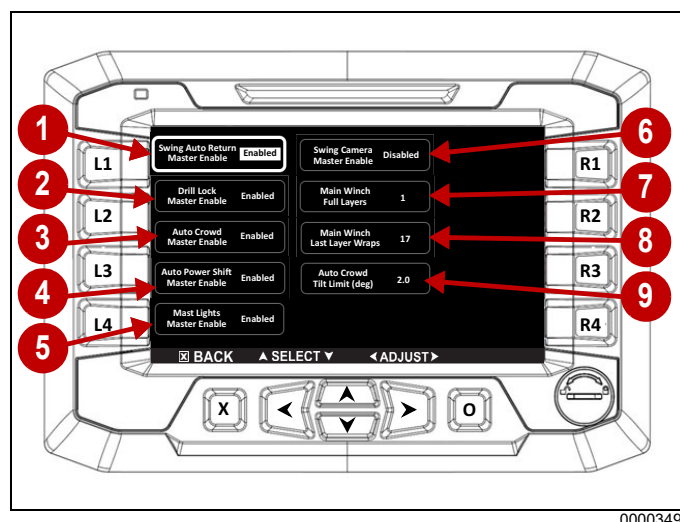

Figure 6-46

Press the R4 switch from the Third Screen - Page 2 to access the Settings Screen. The following machine settings and parameter changes may be made.

Swing Auto Return Master Enable (1) – This function controls the automatic return of the machine to the hole center. Enabled or Disabled can be selected. When enabled, the swing auto return is accessed on the Third screen. See “Third Screen” on page 6-23.

Drill Lock Master Enable (2) – This function controls the locking function for the drilling rotation, which makes the drill lock operational. Enabled or Disabled can be selected.

Auto Crowd Master Enable (3) – This function controls the automatic crowd force system to maintain a constant crowd force pressure during drilling operations. Enabled or Disabled can be selected. Auto crowd is operational when Enabled is selected.

Auto Power Shift Master Enable (4) – This function engages power shift operation automatically when the depth reading is negative (the auger is above ground level). Enabled or Disabled can be selected.

Mast Lights Master Enable (5) – This function controls mast light operation. Enabled or Disabled can be selected. The mast lights icon and mast lights switch are accessed from the Home Screen. See “R3 – Mast Lights Switch” on page 6-17.

Swing Camera Master Enable (6) – Enables or disables the side camera when the swing function is actuated. Enabled or Disabled can be selected. Selecting Enabled allows swing camera operation. See “R2 – Swing Camera Switch” on page 6-16.

Main Winch Full Layers (7) – Displays the number of cable layers being used on the main winch drum when the kelly bar is at the limit switch stop.

NOTE: This setting is important for correct depth measurement. Make sure the full layers on the drum are with the kelly bar in the full up position.

Main Winch Last Layer Wraps (8) – Displays the number of wraps on the last layer of the main winch drum.

NOTE: This setting is important for correct depth measurement. The amount of wraps on the last layer should be made with the kelly bar in the full up position.

Auto Crowd Tilt Limit (deg) (9) – Sets the maximum allowable angle for drilling produced by the crowd force during operation. This setting is used to prevent overcrowding. OFF or ON can be selected:

- OFF – The machine uses the set parameter to alert the operator of overcrowding.
- ON – The machine uses the set parameter slow the crowd function and prevent overcrowding.

CONTROLS

Active Faults Screens

Active Fault Indications

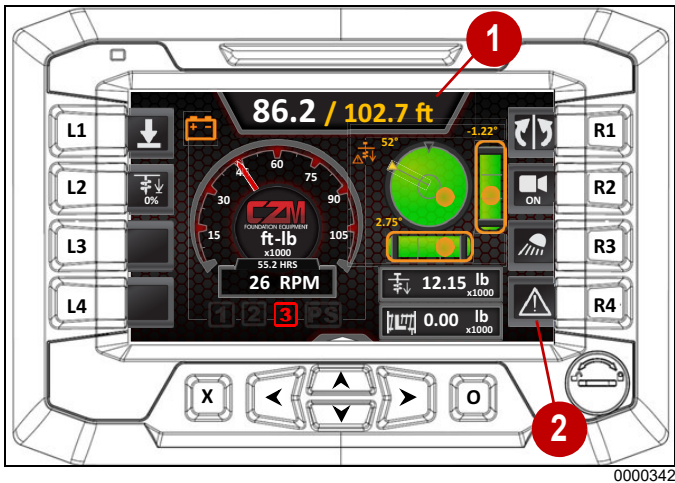

Figure 6-47: Active Fault Indications

When there are active faults, an alert message (!FAULT!) (1) displays at the top of the Home Screen in place of the current/maximum drill operation depth indicators. When this occurs, the R4 switch alert icon (2) will flash.

Press the R4 switch to access the second active fault screen. The faults are displayed with their fault ID number and description. See “Active Fault Display Screen” on page 6-28.

Active Fault Display Screen

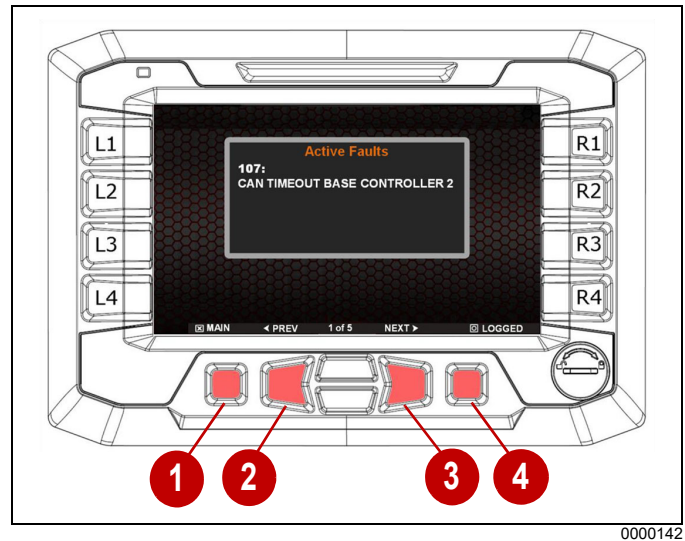

Figure 6-48: Fault Display

Active Faults screen—2 button functions:

- Press the MAIN button (1) to return to the main screen.
- Press the previous (PREV) button (2) or the NEXT button (3) to scroll between faults displayed, if any are present.
- Press the LOGGED button (4) to access the logged active faults message screen.

CAT® Monitoring System*

⚠ WARNING

Do not operate the machine if the monitor is not functioning. For example, the monitor has a black screen or is not responding when the key switch is in the ON position.

The monitor provides images from the camera system and other information for safe machine operation. Operating the drilling rig without a properly functioning monitor may result in injury or death.

If the monitor is not functioning, place the drilling rig in a safe state by following the procedures for stopping and parking the machine. Determine the cause of the monitor malfunction and correct it before returning the machine to service.

SMCS Code: 7451; 7490

IMPORTANT

When the monitor provides a warning, immediately check the monitor and perform the required action or maintenance as indicated by the monitor.

The monitor indicator does not guarantee that the machine is in a good condition. Do not use the monitor panel as the only method of inspection. Maintenance and inspection of the machine must be performed on a regular basis. See the Maintenance Section of this Operation and Maintenance Manual.

General Information*

NOTE: Your machine may not be equipped with all the functions described in this topic.

The monitoring system is an input and an output of the Machine Control System. The monitor has a multi-touch 8- or 10-inch display. The Machine Control System communicates back and forth on the data link. The monitoring system consists of the following components:

- Display (with numerous screens and menus)
- Indicators
- Gauges
- Soft Switch Panel
- Jog Dial

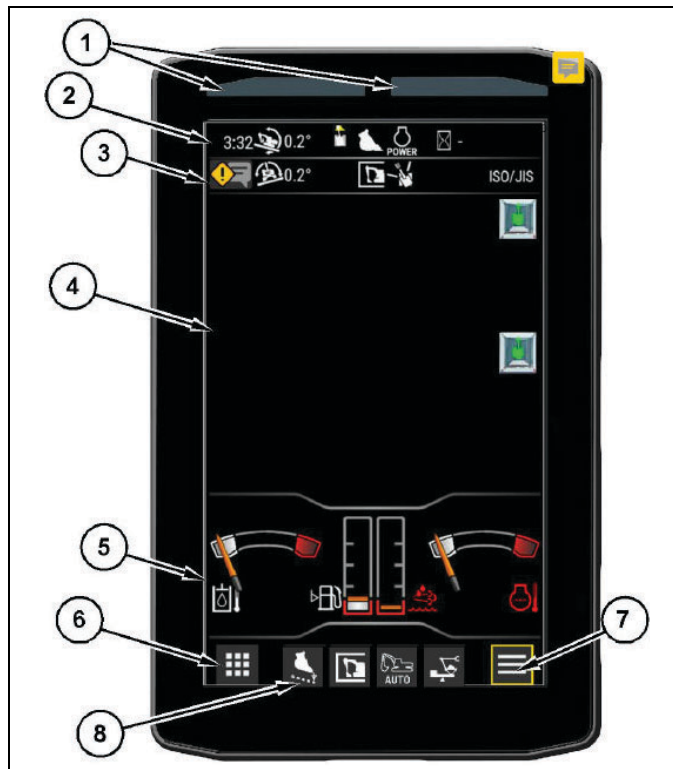

Figure 6-49: CAT Monitor - Main Elements

- (1) Action Lamps
- (2) Status Information Area
- (3) Event Indicator Area
- (4) Camera View Area
- (5) Gauge Area
- (6) Navigation Area
- (7) Function List
- (8) Shortcuts

The monitoring system displays various warnings and information about the condition of the machine, and the machines surrounding with various camera views. There are gauges and several alert indicators included on monitoring system display. Each gauge is dedicated to a parameter within a machine system. The monitoring system will allow the user to do the following:

- View Surroundings
- Interpret status information
- Interpret parameters
- View OMM
- View service intervals
- Perform calibrations
- Troubleshoot machine systems

CONTROLS

Action Lamps (1)

The action lamps illuminate to show that a problem has occurred with the machine.

Status Information Area (2)*

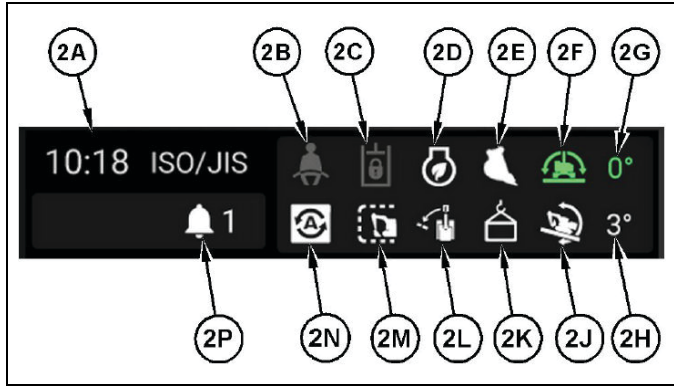





Figure 6-50: CAT Monitor - Status Information

- (2A) Multi Status Information
- (2B) Seatbelt Switch Status (if equipped) / Power Mode
- (2C) Hydraulic Lockout Control
- (2D) Eco Mode
- (2E) Work Tool
- (2F) Not Applicable
- (2G) Not Applicable
- (2H) Not Applicable
- (2I) Not Applicable
- (2J) Not Applicable
- (2K) Heavy Lift / CAT® Dig Boost (if equipped)
- (2L) Not Applicable
- (2M) Not Applicable

Reference: For complete status information, refer to *Operation and Maintenance Manual, M0109053, "Next Generation Hydraulic Excavator Monitoring System Supplement"*.

Multi Status Information (2A)

-  Service Hour Meter (2A) – Shows the total operating hours of the engine. Use the display to determine the service hour maintenance intervals.
-  Soot Load (2A) – The amount of soot built up in the Diesel Particulate Filter (DPF) at the time of regeneration.
-  Time To Regen (2A) – Shows the estimated time left for regeneration.



Fuel Consumption Rate (2A) – Displays fuel consumption per hour. Fuel consumption can be measured in liters or gallons.



Fuel Remain Time (2A) – Shows the estimated time until fuel is empty.



Machine Rotation Angle (2A) – Indicates the rotation angle the of machine.



Tool name (2A) – Shows the tool name selected.

NOTE: When the cursor is on this area, the information can be changed by touching the area or by rotating the jog dial.

Seatbelt Switch Status (If equipped) / Power Mode (2B)



Not Fastened (2B) – Displays when the seatbelt is not fastened.



Smart Mode (2B) – This indicator shows that the machine is set to operate in the SMART mode.



Economy Mode (2B) – This indicator shows that the machine is set to operate in the Economy Mode.

NOTE: "ECONOMY" mode is not available on GC models.



Power Mode (2B) – This indicator shows that the machine is set to operate in the Power Mode.



Disabled (2B)

Notification Center Icon (3)*

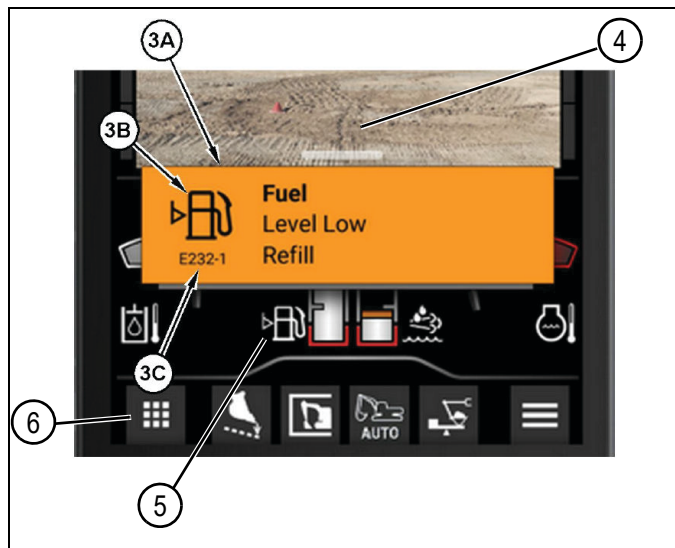

Figure 6-51: Event Indicator Area

g06720210

- (3A) Event Description
- (3B) Event Symbol
- (3C) Event ID
- (4) Camera View
- (5) Gauge Area
- (6) Navigation Bar

Event Description (3A) – This area will display the description of pop-up message of the impending problem.

- Line 1: System
- Line 2: Condition
- Line 3: Action to be taken

Event Symbol (3B) – This area will display the symbol of the problem

Event ID (3C) – The identification number for the event will be shown here.

Camera View (4)*

This area on the monitor displays the view of the cameras. A rear view camera mounted on top of the counterweight and an optional side view camera mounted in the side panel next to the hydraulic tank.

If both rear view camera and side view camera are equipped, the monitor screen can be toggled to show:

- Rear only
- Side only
- Split vertically
- Split horizontally

The camera view can be toggled when the cursor is on the camera view area and the area is touched or the jog dial is turned.

360 Visibility (If Equipped)



0000873 0000874

Figure 6-52: Front and Side Cameras

CONTROLS

If equipped with the optional side and front cameras, the 360 visibility feature can be toggled on and off to enable or disable the 360 degree visibility view in the monitor.

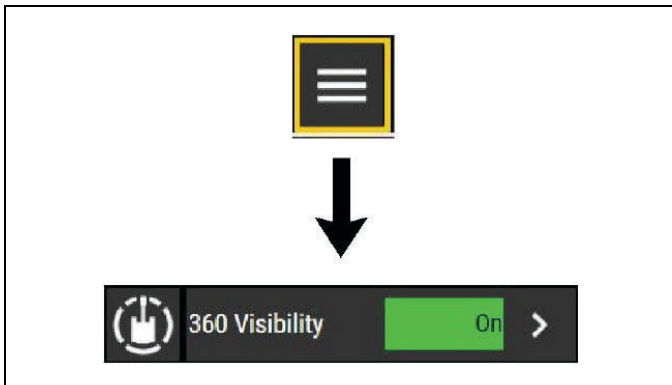

Figure 6-53: Visibility

From the main screen, press the Function List icon. In the Function List menu, select “360 Visibility”.

NOTE: The 360 visibility system has been set up by the factory to provide views which comply with specified machine-side views. Consult CZM before any adjustments are made to the system.

Gauge Area (5)*



Fuel Level – This gauge indicates the amount of fuel that is remaining in the fuel tank. When the fuel gauge is in the red range, add fuel immediately.



Hydraulic Oil Temperature – This gauge indicates the temperature of the hydraulic oil. The normal operating range is the green range. If the gauge is in the white range, the engine and machine warm-up is required. Refer to Operation and Maintenance Manual, “Engine and Machine Warm-up.” If the gauge reaches the red range, reduce the load on the system. If the gauge stays in the red range, stop the machine and investigate the cause of the problem.



Engine Coolant Temperature – This gauge indicates the temperature of the engine coolant. The normal operating range is the green range. If the gauge is in the white range, the engine and machine warm-up is required. Refer to Operation and Maintenance Manual, “Engine and Machine Warm-up.” If the gauge reaches the red range, stop the machine and investigate the cause of the problem.



Diesel Exhaust Fluid (DEF) Gauge – This gauge indicates the level of DEF fluid in the DEF tank. When the DEF gauge is in the red range, add DEF immediately.

Navigation Bar (6)*



Apps Key – Allows you to display different information in the gauge area related to operation. Also contains air conditioner and radio controls. This key includes the settings screen allowing change of a multitude of parameters, some password protected.



Function List Key – Allows you to turn on and off various functions related to the active screen. This icon only appears in certain screens where additional settings are necessary.

Shortcuts – Allows you to set certain shortcuts on the navigation bar.

Machine Warnings*

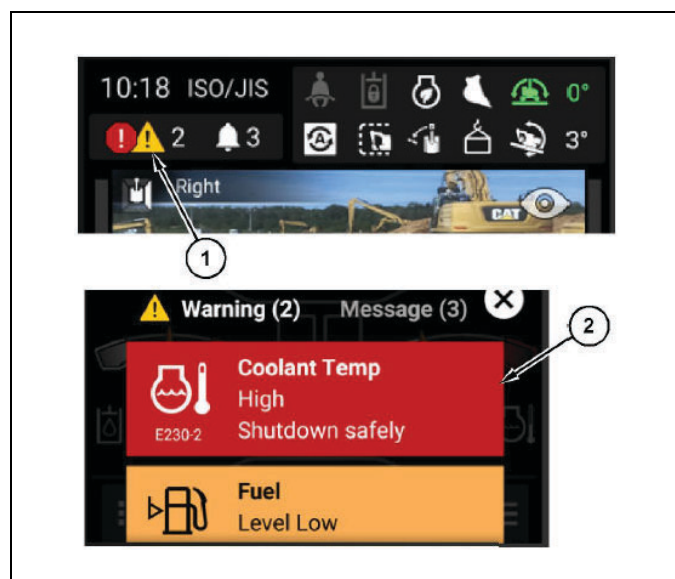

Figure 6-54: Machine Warnings

Event Indicator Area

- (1) Notification Center Icon
- (2) Notification Center Dashboard

The monitor will display warnings, and log events for machine conditions that are not within normal operating parameters.

The event warnings are classified into three warning levels. Warning Level 1 represents the least severe problem and Warning Level 3 represents the most severe problem. The warning levels, monitor response, and the required operator actions are given below.

Warning Level 1 (Gray) – Requires operator awareness. The icon and pop-up message will both appear gray.

Warning Level 2 (Amber) – Requires a change in the operation of the machine or a change in the maintenance of the machine to correct the condition. The icon and pop-up message will both appear amber and the action lamp will blink.

Warning Level 3 (Red) – Requires immediate shutdown of the machine to prevent damage to the machine or personnel. The icon and pop-up message will both appear red, the action lamp will blink, and the buzzer will sound.

When multiple warnings are present in the system, the highest warning is shown first. Press the right or left key to view all the logged warnings. If no keys are pressed within a few seconds, the display will return to the highest warning.

Logging In*



Figure 6-55: Log In

There are different ways to access the monitor which include:

- Guest access
- Passcode access
- Bluetooth access
- Cat® myEquipment app

For more information on logging in, refer to See “Operator Login*” on page 7-22.

Navigation*

The monitor can be navigated by touch screen or the switch panel.

Switch panel components can be used to interface with the monitor in the following ways. Each of the buttons is also assigned a number which is imprinted in the top corner of the button. These buttons can be used to enter the numerical passcodes used to log in to the monitor.

CONTROLS

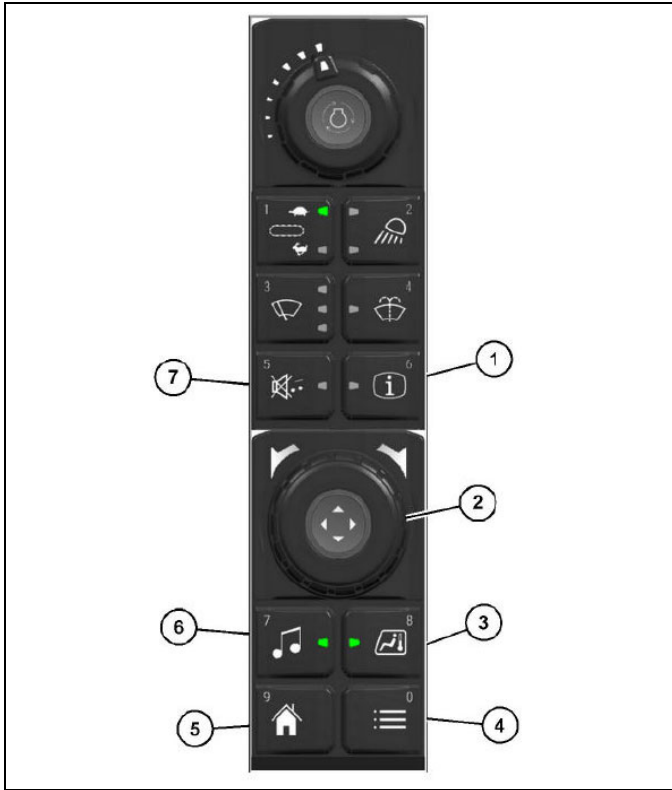

Figure 6-56: Navigation

g06464384

- | | |
|--------------------------------|-----------------|
| 1) Operator information button | 5) Home button |
| 2) Jog dial | 6) Audio button |
| 3) Air conditioner button | 7) Mute button |
| 4) Next menu button | |

Operator Information Button (1) – Press and hold this button to access the operator information screen. This screen shows information such as operator settings.

Jog Dial (2) – Rotate the jog dial to highlight menu items on the monitor. Push the jog dial down to select the highlighted item.

Air Conditioner Button (3) – Press the button to access the air conditioner controls.

Next Menu Button (4) – This button is equivalent to the function list key on the monitor. This button can only be used on screens where the function list key is shown.

Home Button (5) – Press this button to return to the main screen.

Radio Button (6) – Press this button to access the radio controls.

Mute Button (7) – Press this button to mute the radio. Press the button again to unmute the radio.

Radio*

SMCS Code: 7338

The radio is integrated into the monitoring system. All the radio controls are adjusted using the monitor. The actual radio is mounted in the right rear console behind the operator seat.

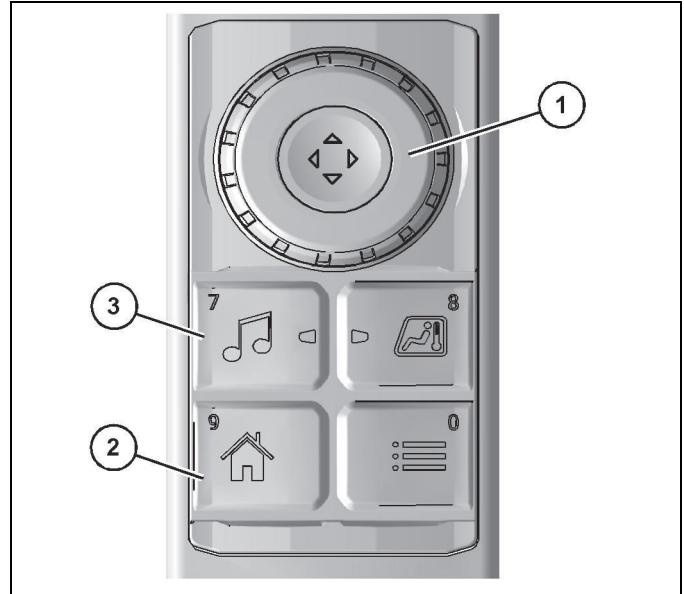

Figure 6-57: Radio Controls

g06213193

- | |
|------------------|
| (1) Jog dial |
| (2) Home button |
| (3) Radio button |

The audio menu can be directly accessed by pressing radio button (3) on the right side switch panel. Input selections can be made using jog dial (1) or using the monitor touch screen. Home button (2) can be used to return to the main screen.

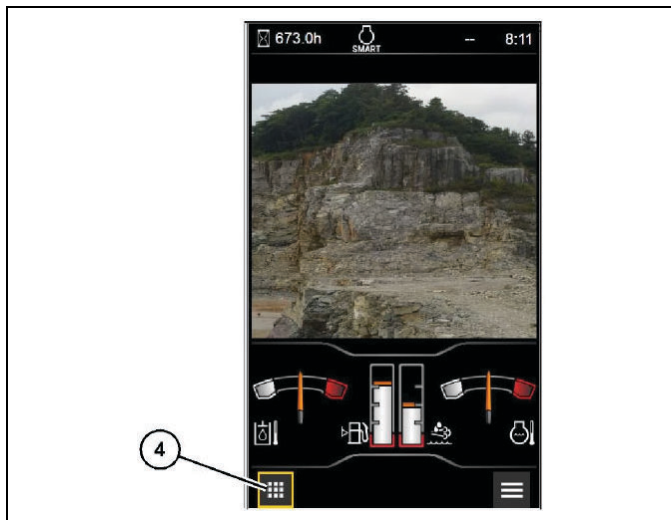

Figure 6-58: Menu Button

Press radio button (3) to go directly to the radio screen. To navigate to the radio screen from the main screen, press application menu button (4).

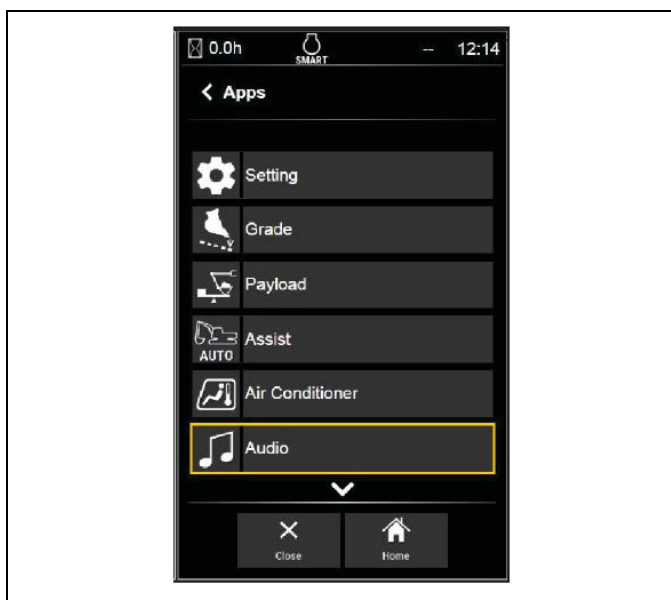

Figure 6-59: Audio Selection Button

Use jog dial (1) to highlight “Audio” and then press the jog dial downward to select the entry. You may also access the screen by simply touching the “Audio” box on the touch screen.

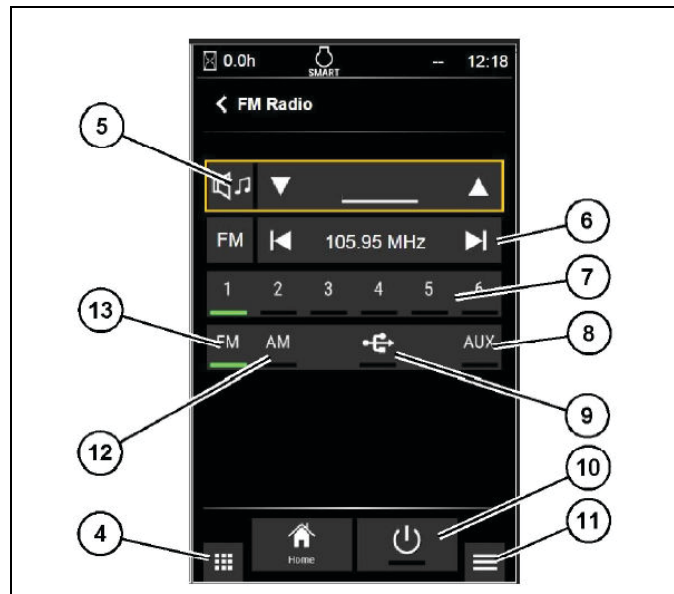

Figure 6-60: Radio Screen

- (4) Application menu button
- (5) Volume control
- (6) Tuner
- (7) Preset stations
- (8) Auxiliary button
- (9) USB button
- (10) Power button
- (11) Radio Function List menu
- (12) AM button
- (13) FM button

Application menu button (4) – Use this button to return to the application menu.

Volume control (5) – The volume control is used to raise or lower the audio volume.

Tuner (6) – The tuner is used to tune the radio to the desired station.

Preset stations (7) – The preset stations store favorite radio stations for the operator. To set a station, tune to the desired station. Press and hold the preset number you want to assign to that station. Once a beep is heard, release the button. The indicator light for the active preset station will illuminate.

Auxiliary button (8) – When a device is plugged into the auxiliary port, press the auxiliary button to connect the device to the radio. The indicator light will illuminate when this mode is active.

USB button (9) – When a device is plugged into the USB port, press the USB button to connect the device to the radio. The indicator light will illuminate when this mode is active.

CONTROLS

Power button (10) – Pressing this button turns the radio on and off. The indicator light on the monitor and on button (3) will illuminate when the power is on.

Radio function list menu button (11) – Pressing this button leads to the radio function list menu.

AM button (12) – Press this button to access AM radio. The indicator light will illuminate when this mode is active.

FM button (13) – Press this button to access FM radio. The indicator light will illuminate when this mode is active.

Radio Function List*

To access the radio function list, press the function list button (11) in the lower right corner of the radio screen.



Figure 6-61: Radio Function List

The function list menu consists of the following items:

Treble – Allows the user to adjust the treble.

Bass – Allows the user to adjust the bass.

Balance – Allows the user to adjust the balance between speakers.

Auto Loudness – When on, this feature automatically adjust treble and bass levels when reducing the volume setting. This effect allows the user to hear more clearly at a lower volume.

Bluetooth – Allows the user to pair a phone, view paired devices, and edit device names.

Refer to Operation and Maintenance Manual, Monitoring System - Bluetooth for information on the Bluetooth screen.

Selection Method*

All settings can be made using the touch screen or by using the jog dial. The method depends on the preference of the operator. When using the touch screen, simply touch the icon you want to select. When using the jog dial, rotate the dial to switch to different selections within the screen. Press the jog dial downward to choose a selection.



Figure 6-62: Radio Selection Method

When using the jog dial to set the volume or tuner, rotate the dial clockwise to increase and counterclockwise to decrease. Press downward on the dial to enter the desired setting.

Radio Operation*

1. To operate the system, press power button (10).
2. Select between the AM button for AM stations or select the FM button for FM stations.
3. Use tuner (6) to adjust to the desired station. If presets stations (7) are set, press the desired preset station.
4. Use volume control (5) to adjust the volume.
5. When the machine is in operation turn down the volume of the radio.

USB/AUX Operation*

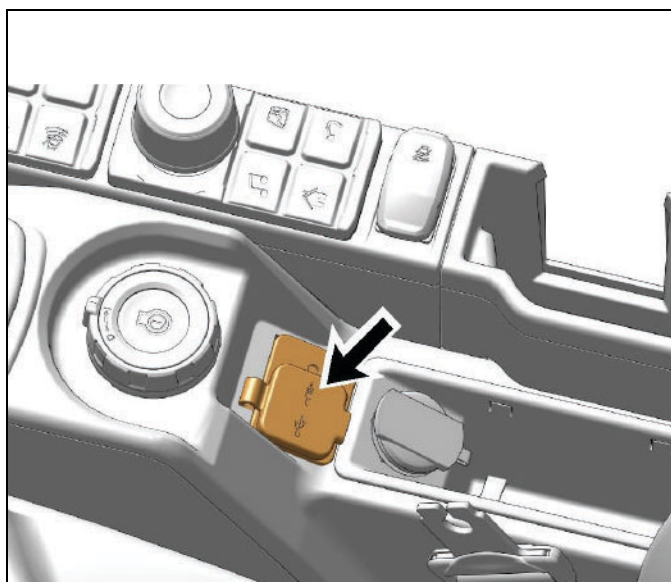

Figure 6-63: USB AUX

1. To play music from a device such as an MP3 player or a phone, connect the device using an auxiliary cable or a USB cable. Depending on the cable being used, plug the cable into the appropriate port on the console.
2. Select either USB or AUX depending on which type of cable was used. Play the music from the device. The music should be playing over the radio speakers if properly connected. Adjust the volume as necessary.

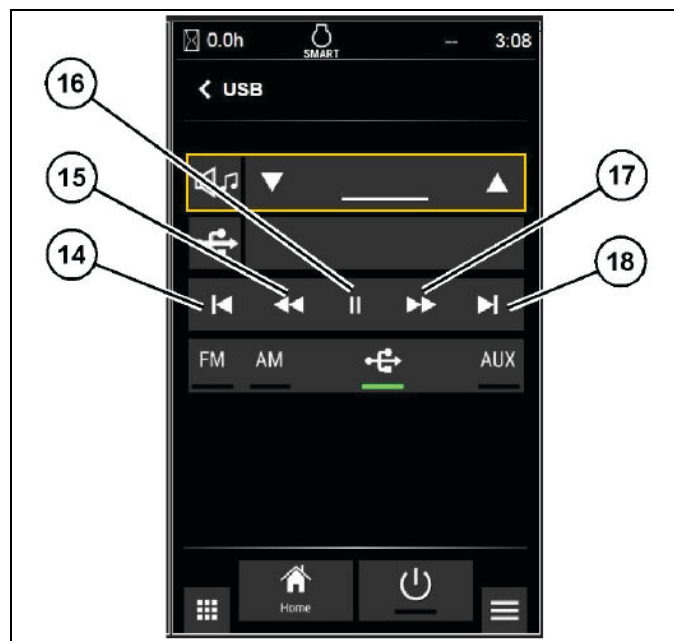

Figure 6-64: USB Controls

NOTE: If USB is selected, extra controls appear on the screen for playing music. They include the following:

- 14** – Skip to the beginning of the track
- 15** – Rewind the track
- 16** – Pause/Play the track
- 17** – Fast forward the track
- 18** – Skip to the end of the track

CONTROLS

Air Conditioning and Heating Control*

SMCS Code: 7304; 7320; 7337

Consult with your Cat dealer for periodic maintenance of the heating and air conditioning system.

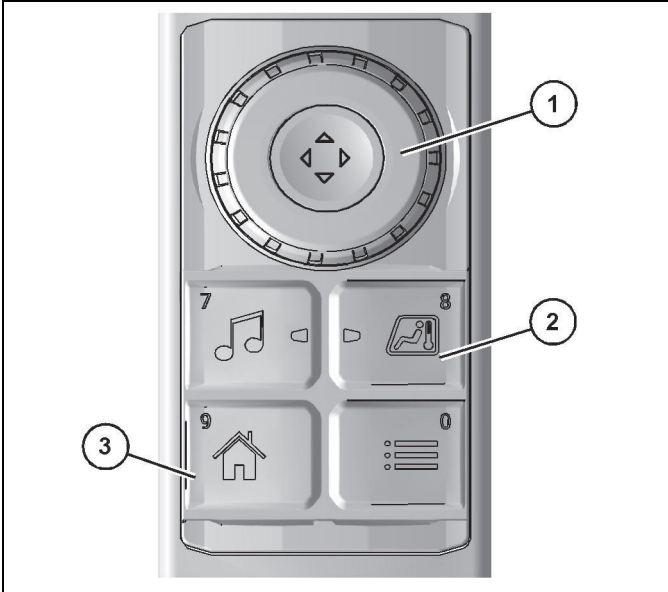

g06178710

Figure 6-65: Air Conditioning and Heating Controls

- (1) Jog dial
- (2) Heating and air conditioning button
- (3) Home button

Air conditioning and heating functions are controlled through the monitor. The heating and cooling menu can be directly accessed by pressing button (2) on the right side switch panel. Input selections can be made using jog dial (1) or using the monitor touch screen. Home button (3) can be used to return to the main screen.

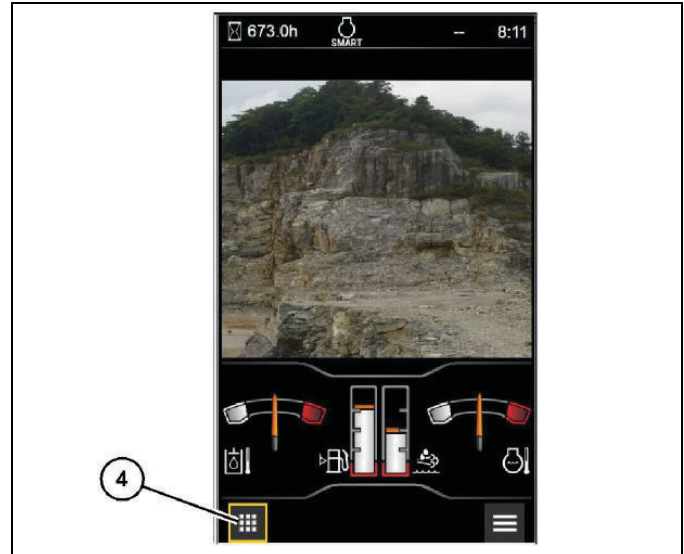

g06213076

Figure 6-66: Menu Button

Press the air conditioning and heating button (2) to go directly to the air conditioner screen. To navigate to the air conditioner screen from the main screen, press application menu button (4).



g06213088

Figure 6-67: Air Conditioning and Heating Button

Use jog dial (1) to highlight "Air Conditioner" and then press the jog dial downward to select the entry. You may also access the screen by simply touching the "Air Conditioner" box on the touch screen.

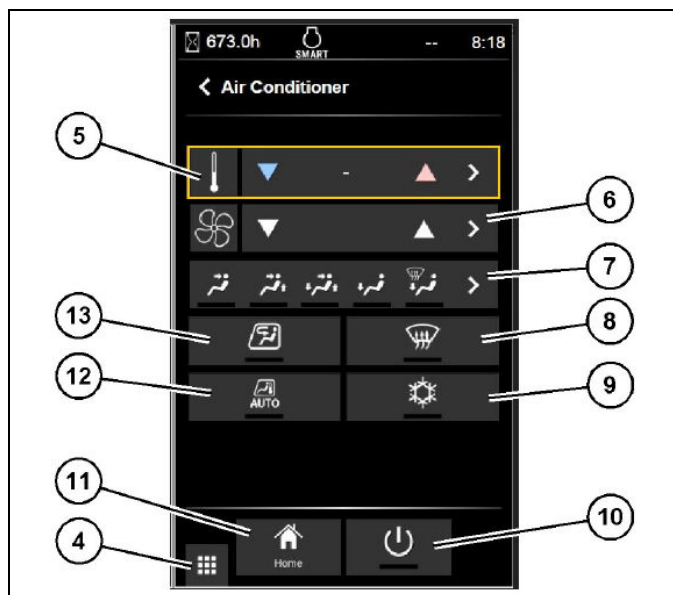

Figure 6-68: Air Conditioner Screen

- (4) Application menu button
- (5) Temperature control
- (6) Fan blower speed control
- (7) Air outlet settings
- (8) Defroster
- (9) Compressor ON/OFF
- (10) Power
- (11) Home button
- (12) Auto
- (13) Recirculation

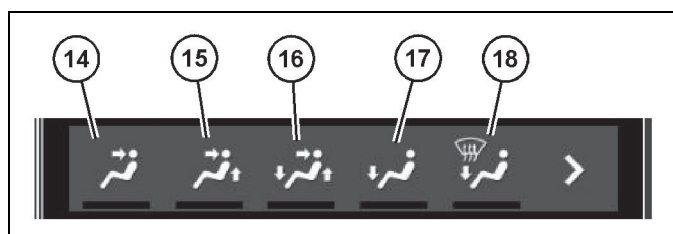

Figure 6-69: Vents

- 14) Front vents
- 15) Front and rear vents
- 16) Front, foot, and rear vents
- 17) Foot vents
- 18) Defrost and foot mode

Application menu button (4) – Use this button to return to the application menu.

Temperature control (5) – The temperature control is used to raise or lower the desired temperature.

Fan blower speed control (6) – The blower control is used to increase or decrease the desired blower speed.

Air outlet settings (7) – The desired air outlet setting can be chosen from this panel. The indicator light will illuminate to show the active setting.

Defroster (8) – Pressing this button activates and deactivates the defroster. Use the defroster to remove steam and frost from the windows. The indicator light will illuminate when this mode is active.

Compressor ON/OFF (9) – Pressing this button activates and deactivates the air conditioner. The indicator light will illuminate when this mode is active.

Power (10) – Pressing this button turns the heating and cooling system on and off. Push and hold the power button for 3 seconds to turn OFF the HVAC system. The indicator light on the monitor and on button (2) will turn green when power is on.

Home button (11) – Use this button to return to the main screen.

Auto (12) – Select this option to hold the system at the desired temperature. The system will modulate to keep the cab at the temperature that the system is set to. The indicator light will illuminate when this mode is active.

Recirculation (13) – This option recirculates air from the cab instead of pulling air from the outside. This mode is more efficient because the system is recycling conditioned air from the cab. However, no fresh air is coming into the cab when in this mode. The indicator light will illuminate when this mode is active.

Front vents (14) – In this mode, air will only circulate from the front vents.

Front and rear vents (15) – In this mode, air will circulate from the front vents and rear vents.

Front, foot, and rear vents (16) – In this mode, air will circulate from the front vents, rear vents, and foot vents.

Foot vents (17) – In this mode, air will only circulate from the foot vents.

Defrost and foot mode (18) – In defrost mode, air will circulate from the front vents and foot vents.

CONTROLS

Selection Method*

All settings can be made using the touch screen or by using the jog dial. The method depends on the preference of the operator. When using the touch screen, simply touch the icon you want to select. When using the jog dial, rotate the dial to switch to different selections within the screen. Press the jog dial downward to choose a selection.

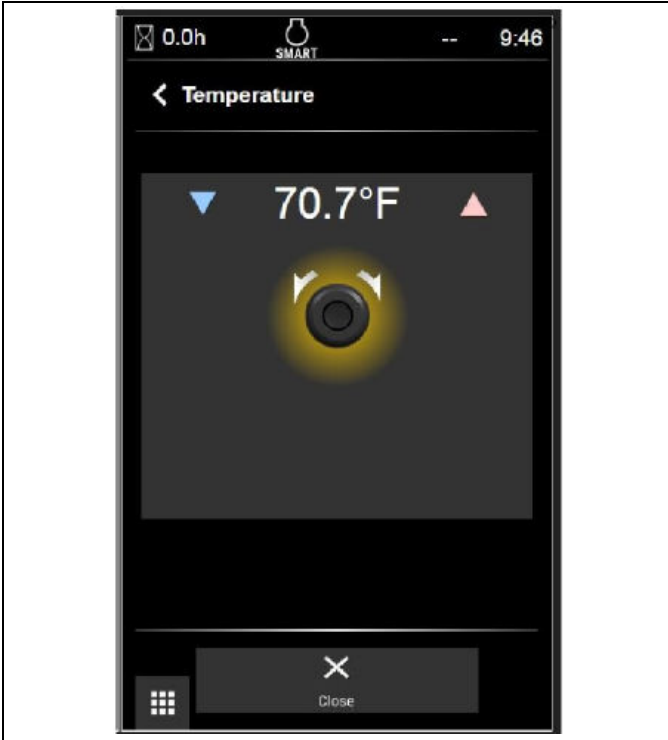

Figure 6-70: Temperature Setting

g06213141

When using the jog dial to set the temperature or blower speed, rotate the dial clockwise to increase and counter-clockwise to decrease. Press downward on the dial to enter the desired setting.

Operation*

1. To operate the system, press power button (10).
2. Use temperature control (5) to adjust to the desired temperature.
3. Select the desired mode and outlet vents.
4. Use fan blower speed control (6) to adjust the blower. If the system is in "Auto" mode, the blower fan speed and air outlet setting will automatically be adjusted. But recirculation air intake is not changed automatically.

NOTE: In cold ambient temperature condition, fan speed is stopped or restricted depend on coolant temperature.

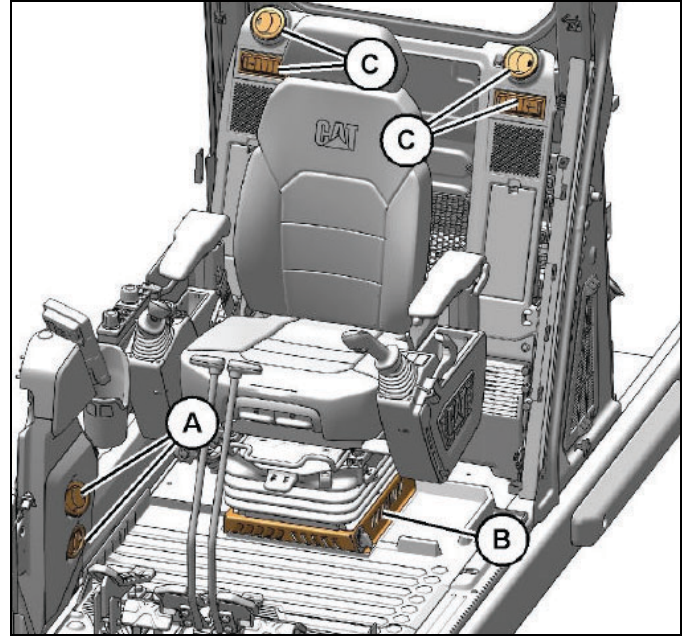

g06178705

Figure 6-71: Vents (1 of 2)

- (A) Defrost vent (front window)
- (B) Foot air vents
- (C) Rear air vents

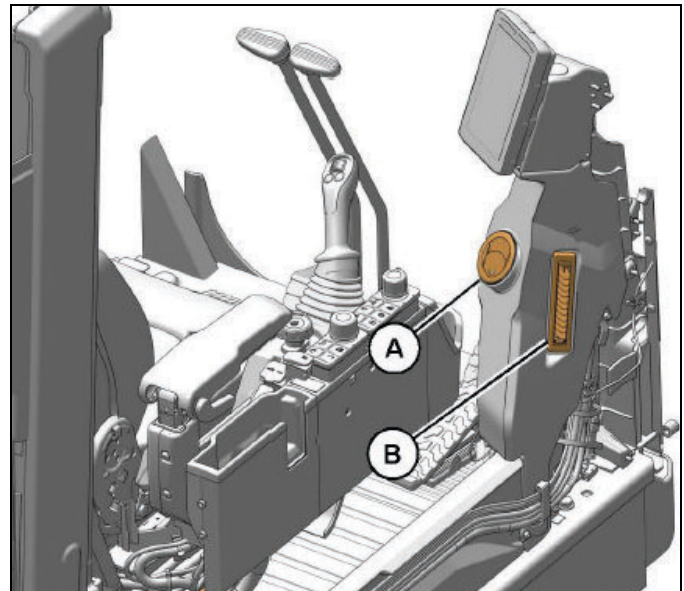

g06287632

Figure 6-72: Vents (2 of 2)

- (A) Front vent
 - (B) Defrost vent (RH window)
5. Redirect the louvers for air outlets (A) and (C) by hand to the desired direction. The louvers for air outlet (B) cannot be redirected.

Operator Screen*



g06241547

Figure 6-73: Operator Information Screen

After logging in, the operator information screen will appear. The screen provides the following information for the logged in operator:

- Operator ID
- Joystick pattern
- Active tool
- Spool response speed
- Joystick button assignments



g06241553

Figure 6-74: Operator Information Button

The operator information screen can be accessed at any time by pressing the operator information button on the right side switch panel.

Application Menu*

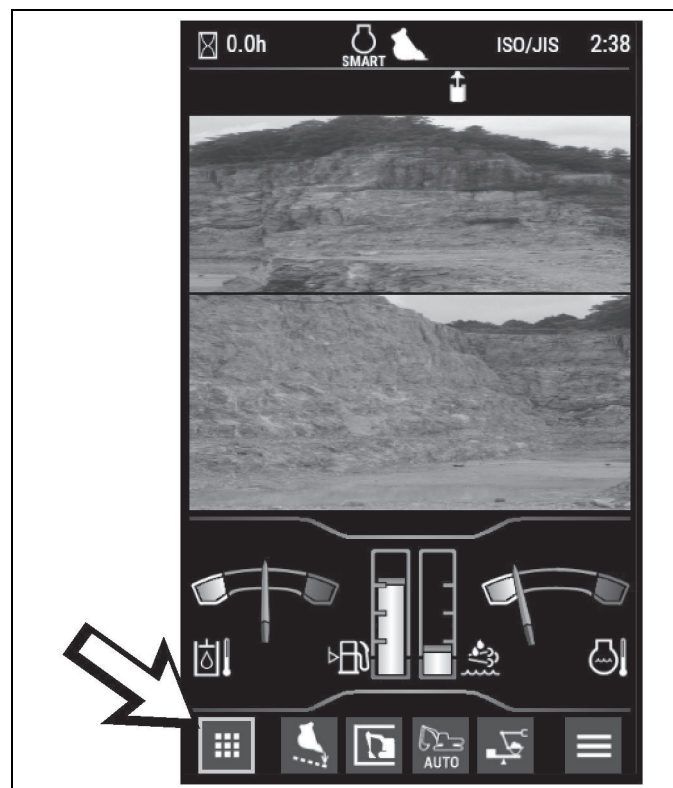

g06391692

Figure 6-75: Application Menu Button

Press the application menu button to access the application menu.



g06247445

Figure 6-76: Application Menu

CONTROLS

The application menu or “Apps” menu contains the following menu items:

- Setting
- Grade
- E-Fence
- Assist
- Payload
- Air Conditioner
- Audio
- Phone
- Bucket/Work Tool Setting
- Electronic OMM

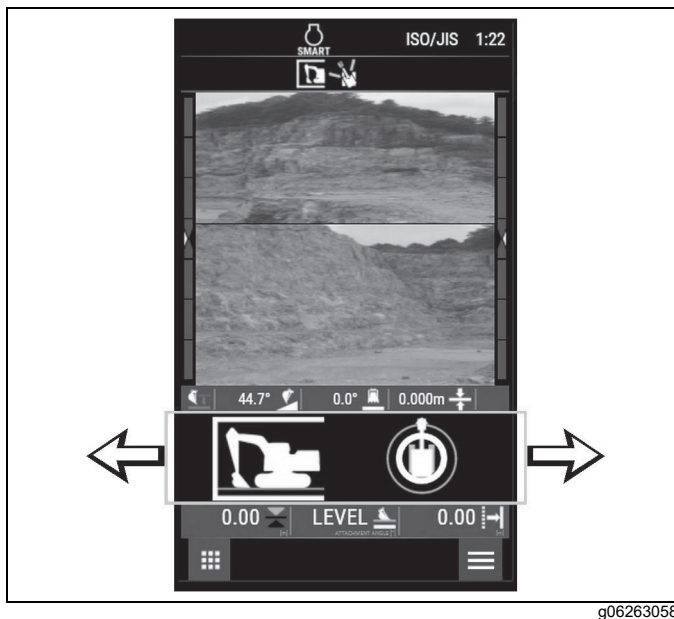

Figure 6-77: Available Applications

Once an “App” has been selected, an operator can sort through the available “Apps” by swiping the selected area left or right.

Setting Menu*

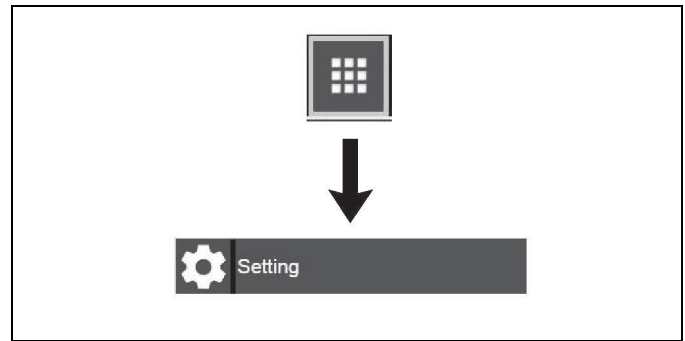

Figure 6-78: Application Setting

From the main screen, press the application menu button. In the Application menu, select “Setting”.

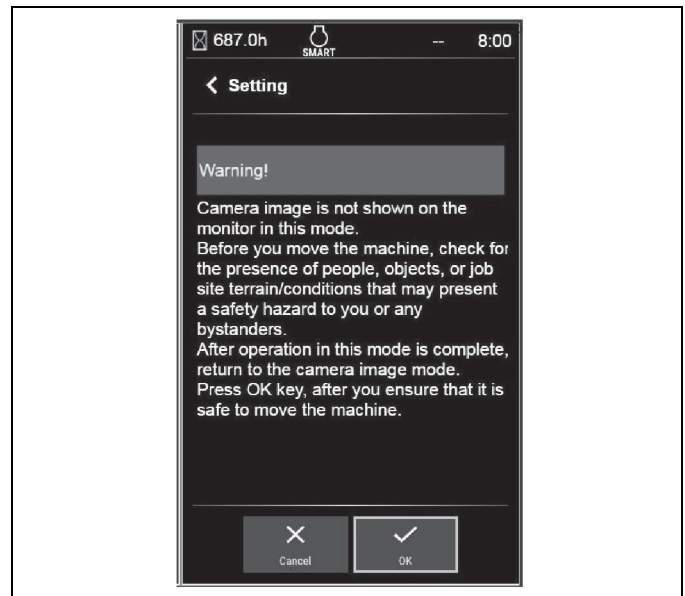

Figure 6-79: Camera Warning

A warning will appear notifying the operator that the camera is not visible in the Setting menu. After you have read the warning and understand the content, press the “OK” button.



Figure 6-80: Setting Menu

The Setting menu contains the following menu items:

- Display Setting
- Information
- Machine Setting
- Operator Setting
- Service

NOTE: A dealer password is necessary to access the Service menu.

Display Setting*

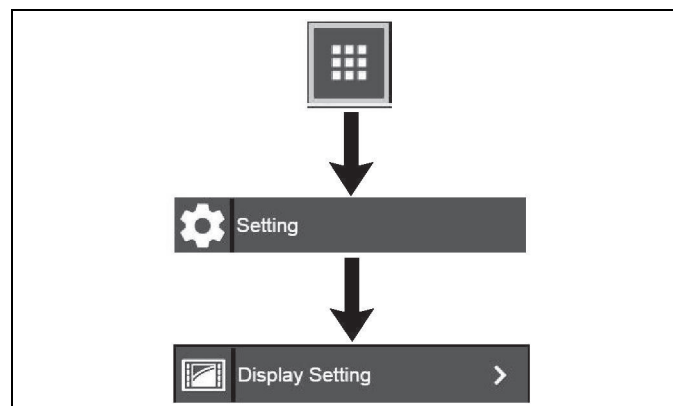

Figure 6-81: Display Setting Button

From the main screen, press the application menu button. In the application menu, select “Setting”. Next, select “Display Setting”.



Figure 6-82: Display Setting Menu

The Display Setting menu contains the following menu items:

- Clock Adjust
- Time Zone
- Brightness Adjust
- Display Unit Select
- Default Camera View
- Language Select

CONTROLS

Clock Adjust*

NOTE: Master level access is required to adjust clock settings.

The clock adjust feature allows the operator to set the clock and set the date.

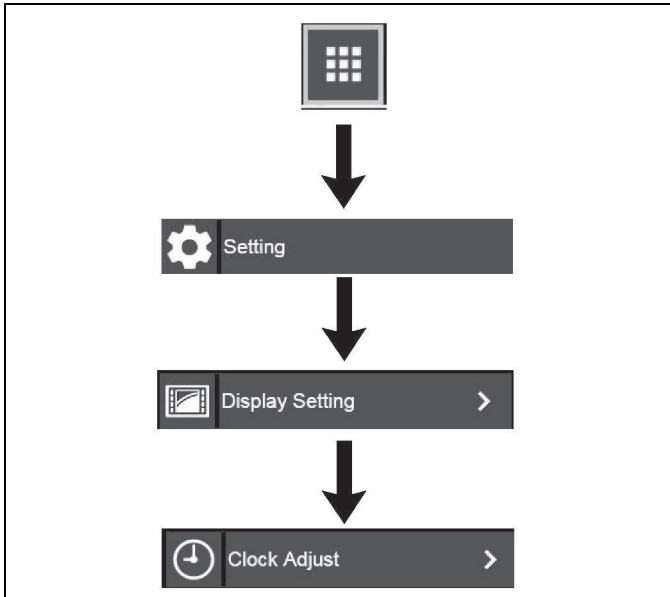

Figure 6-83: Clock Adjust Button

To access the Clock Adjust screen, press the application menu button. Select Setting, Display Setting, then Clock Adjust.



Figure 6-84: Clock Adjust Screen

Adjust the date and time as necessary and select OK. Select the Home button on the Display Setting screen to return to the main screen.

Time Zone*

The time zone feature allows the operator to set the time zone for the region the machine is operating in.

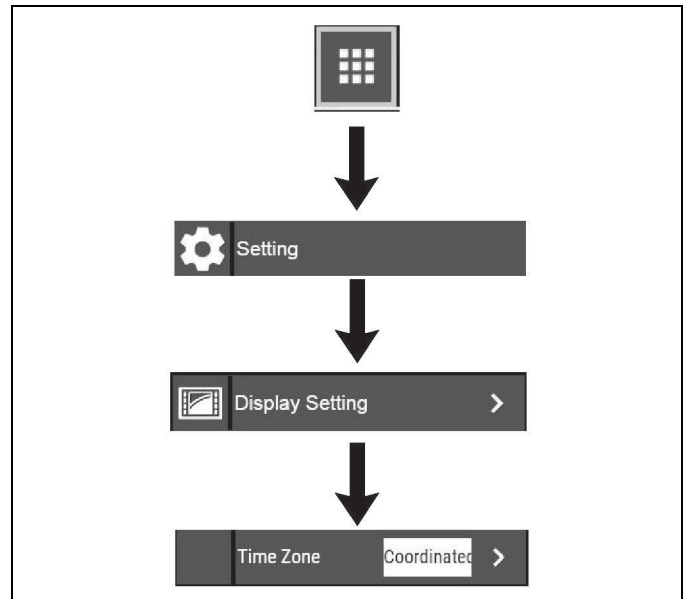

Figure 6-85: Time Zone Button

To access the Time Zone screen, press the application menu button. Select Setting, Display Setting, then Time Zone.



Figure 6-86: Time Zone Screen

Select the correct time zone setting from the list. Select the Home button to return to the main screen.

Brightness Adjust*

The brightness adjust function allows the operator to adjust the brightness of the display for day and night mode.

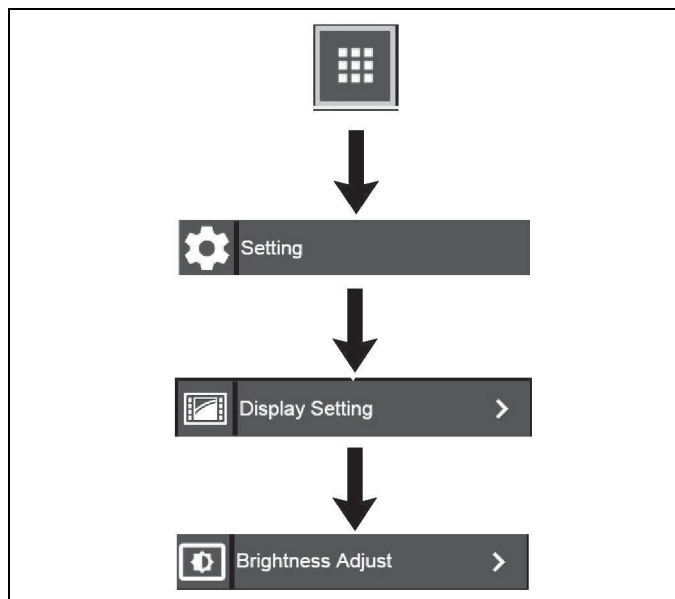

Figure 6-87: Brightness Adjust Button

To access the Brightness Adjust screen, press the application menu button. Select Setting, Display Setting, then Brightness Adjust.



Figure 6-88: Brightness Adjust Screen

Select Day or Night to adjust the brightness level.



Figure 6-89: Brightness Level

Adjust the brightness level then select “Home” to return to the main screen.

Display Unit Select*

Display unit select allows the operator to choose between Metric or English units being displayed.

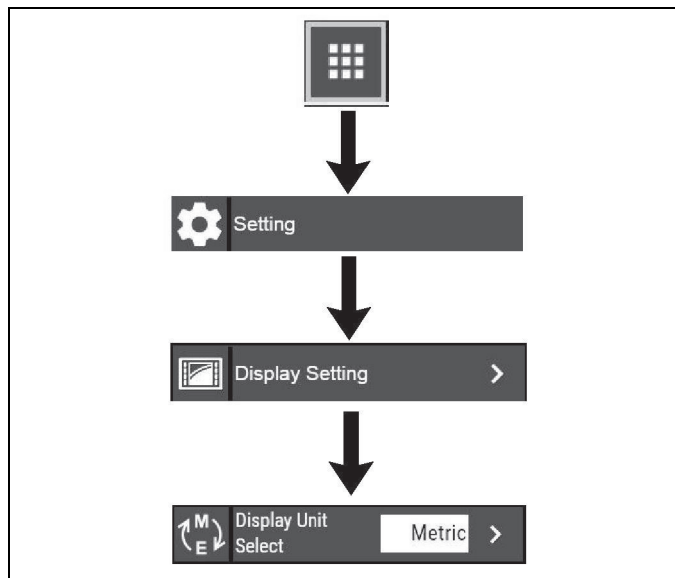

Figure 6-90: Display Unit Select Button

From the main screen, press the application menu button. In the Application menu, select “Setting”. Next, select “Display Setting” and then “Display Unit Select”.



g06241051

Figure 6-91: Display Unit Select Screen

Select either Metric or English then select “Home” to return to the main screen.

Default Camera View*

Default camera view allows the operator to choose the default camera view. The two choices are split screen horizontal or split screen vertical.



g06241057

Figure 6-93: Default Camera View Screen

Select between “Vertical Split” or “Horizontal Split” then select “Home” to return to the main screen.

Language Select*

Language select allows the operator to choose the default language for the monitor.

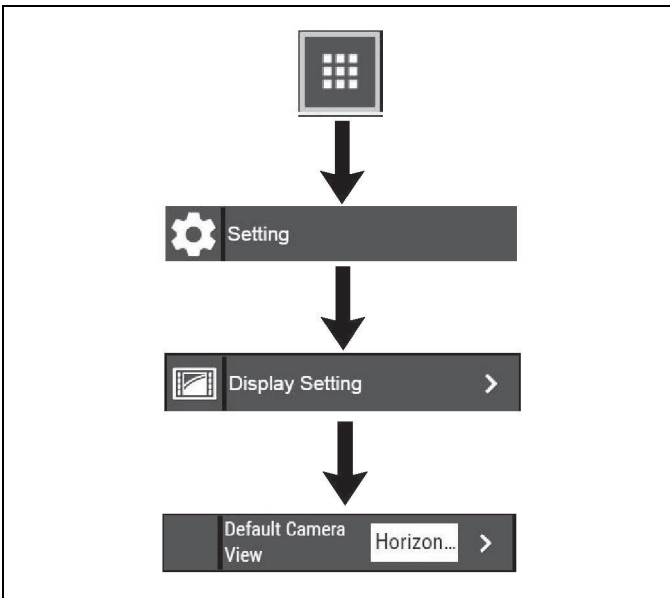

g06241046

Figure 6-92: Default Camera View Button

From the main screen, press the application menu button. In the application menu, select “Setting”. Next, select “Display Setting” and then “Default Camera View”.

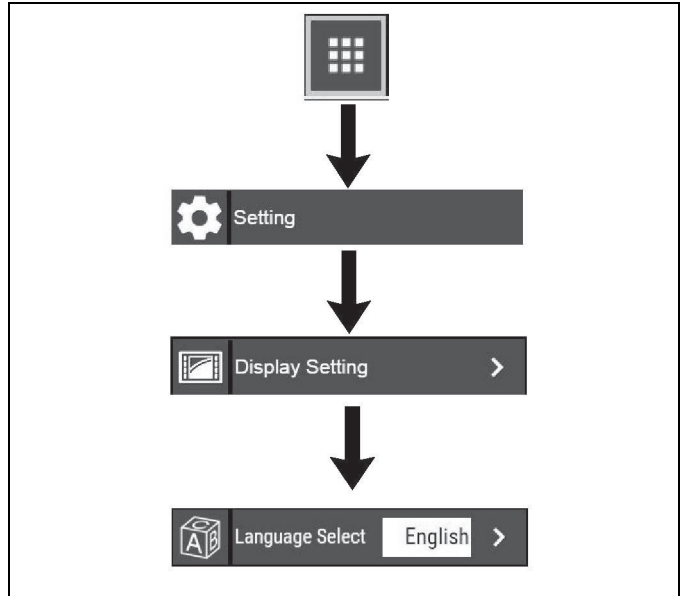

g06241061

Figure 6-94: Language Select Button

From the main screen, press the application menu button. In the application menu, select “Setting”. Next, select “Display Setting” and then “Language Select”.

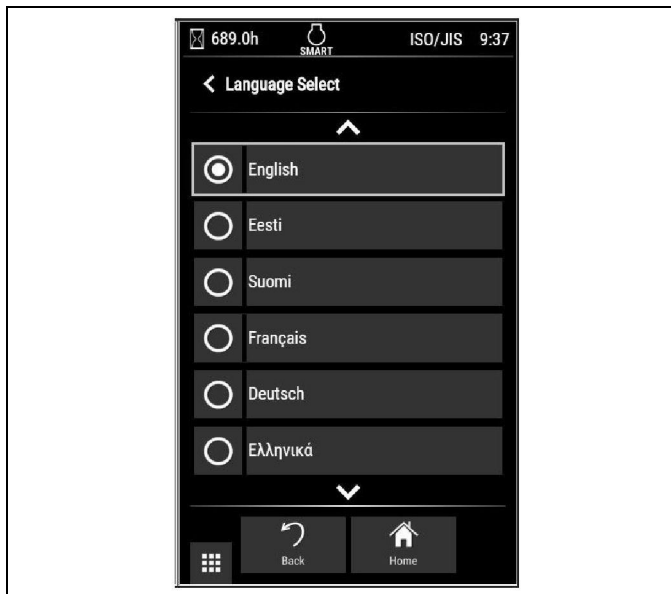

Figure 6-95: Language Select Screen

Select the desired language, then select “Home”. to return to the main screen.

Information*

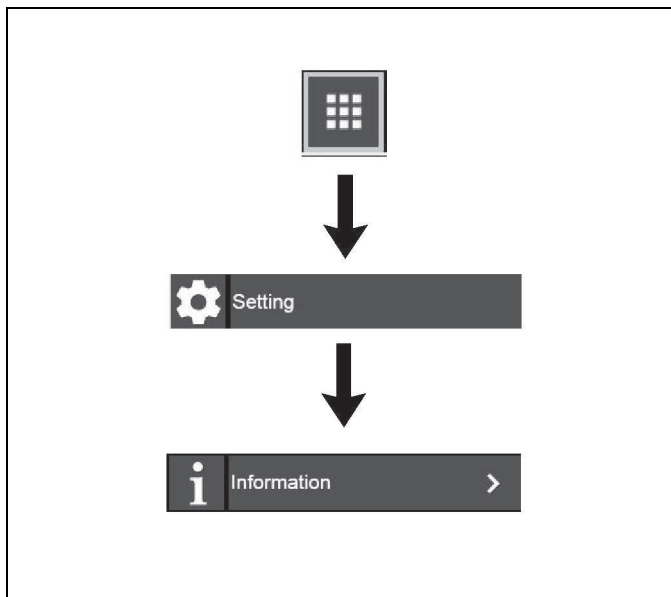

Figure 6-96: Information Button

From the main screen, press the application menu button. In the Application menu, select “Setting”. Next, select “Information”.



Figure 6-97: Information Screen

The Information menu contains the following menu items:

- Performance
- Current Totals
- License Information
- ECM Summary
- Diagnostics

CONTROLS

Performance*

The Performance screen allows the operator to view performance information such as pump outlet pressure and battery voltage.

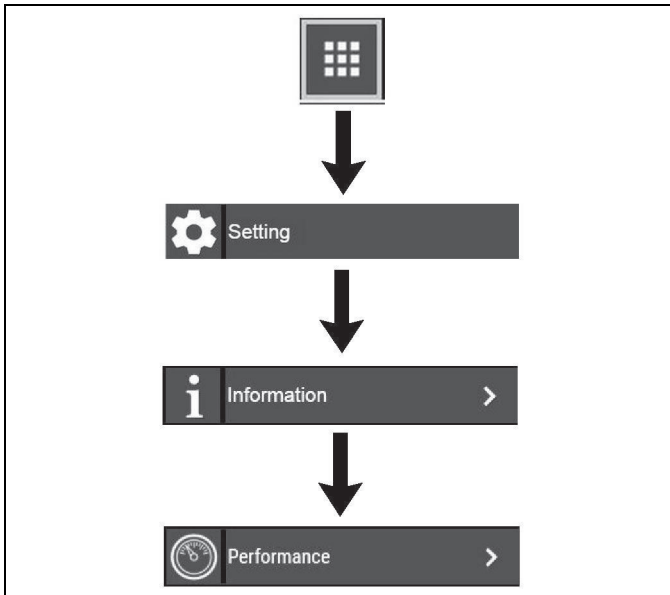

g06261291

Figure 6-98: Performance Button

From the main screen, press the application menu button. In the Application menu, select "Setting". Next, select "Information" and then "Performance".

Current Totals*

The Current Totals screen allows the operator to view operating hours for machine components such as the hydraulic pump and swing motor.

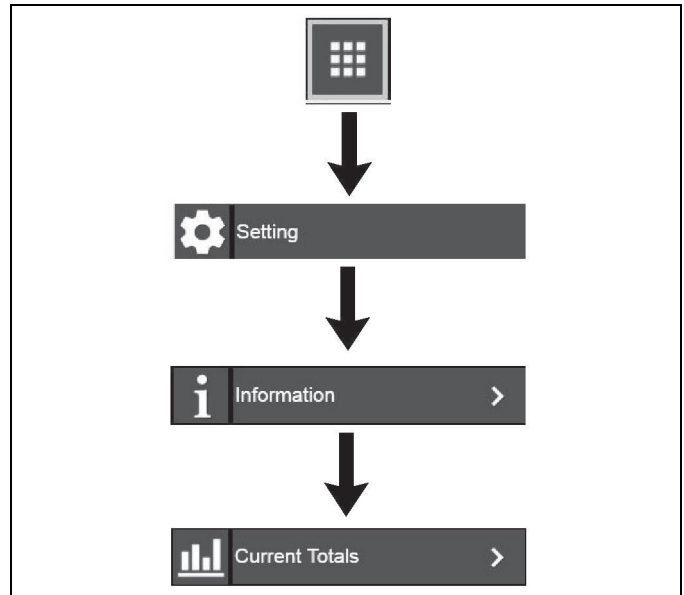

g06261293

Figure 6-100: Current Totals Button

From the main screen, press the application menu button. In the application menu, select "Setting". Next, select "Information" and then "Current Totals".

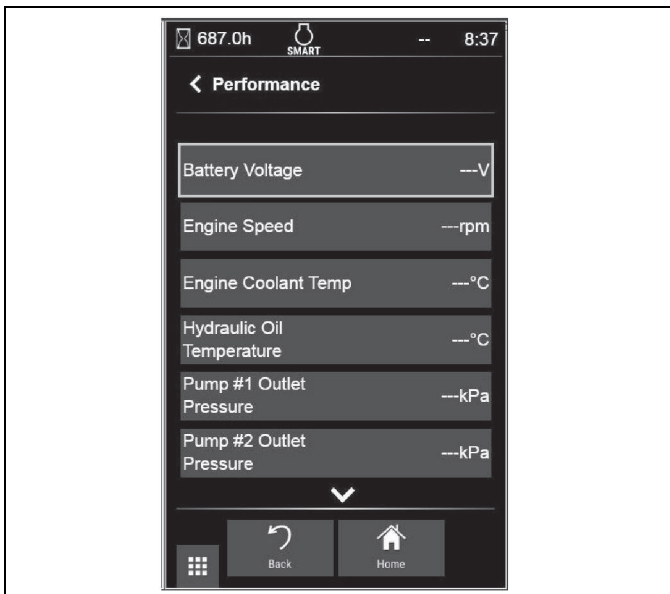

g06217555

Figure 6-99: Machine Performance Screen

Scroll through the list of values to view machine performance. Press the "Home" button to return to the main screen.

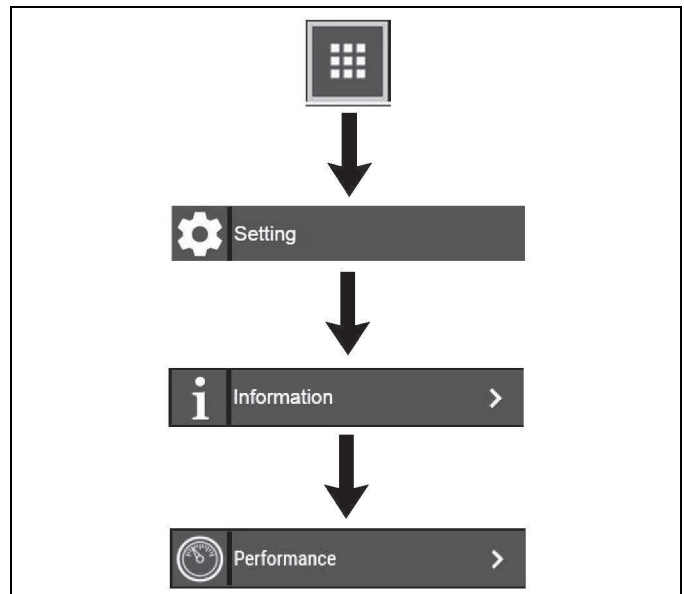

g06217554

Figure 6-101: Current Totals Options

Scroll through the list of values to view component operating hours. Press the "Home" button to return to the main screen.

License Information*

The License Information screen allows the operator or maintenance personnel to view the software license agreement.

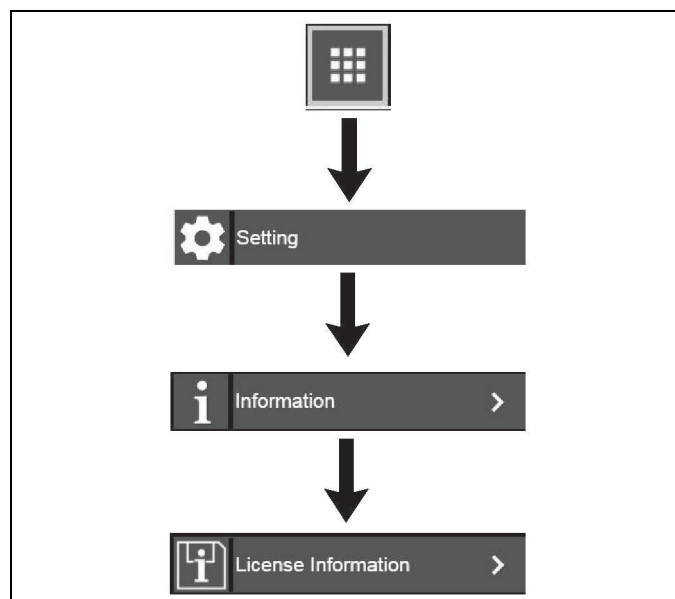

g06261300

Figure 6-102: License Information Button

From the main screen, press the application menu button. In the application menu, select “Setting”. Next, select “Information” and then “License information”.

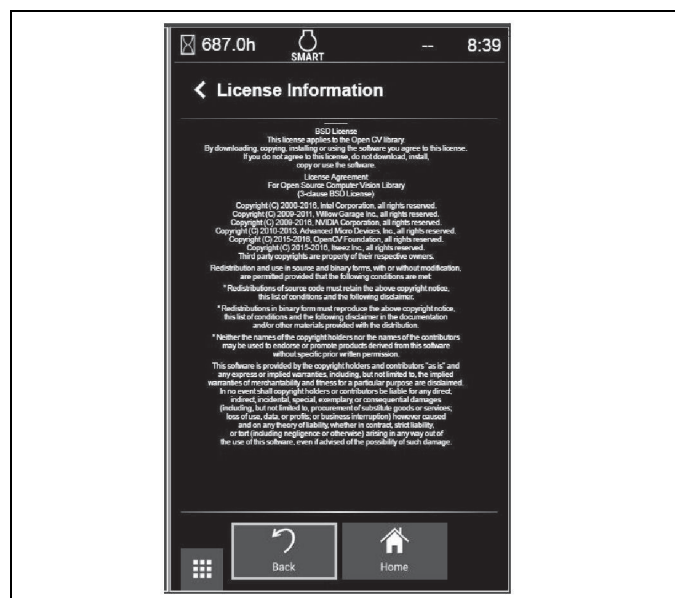

g06217551

Figure 6-103: License Information Screen

Press the “Home” button to return to the main screen.

ECM Summary*

The ECM Summary screen allows the operator to choose any electronic control module (ECM) on the machine and view the following for that ECM:

- Hardware part number
- Hardware serial number
- Software description
- Software part number
- Software release date

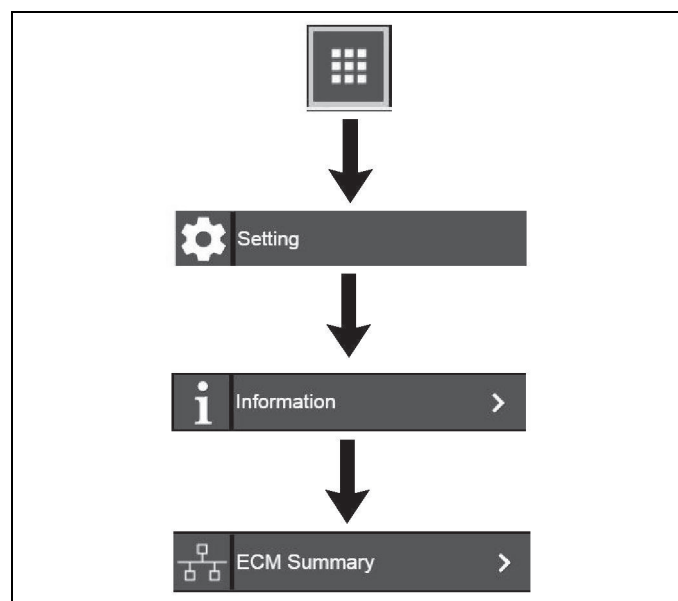

g06261304

Figure 6-104: ECM Summary Button

From the main screen, press the application menu button. In the Application menu, select “Setting”. Next, select “Information” and then “ECM Summary”.

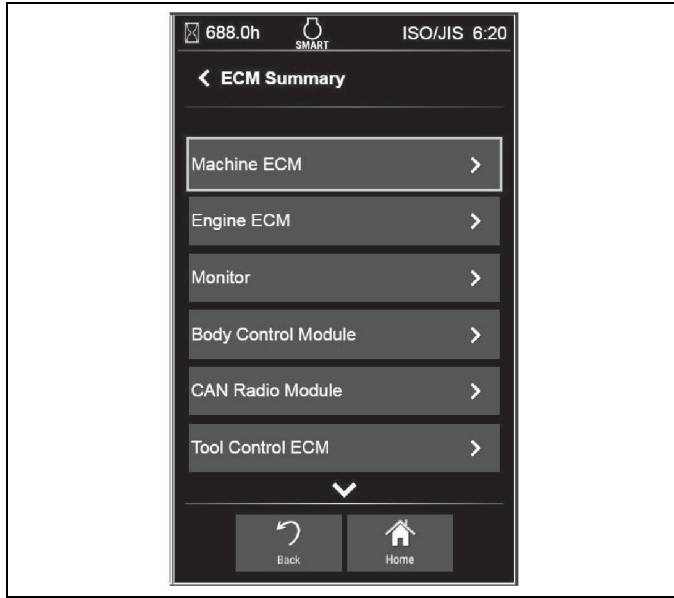

g06242055

Figure 6-105: ECM Summary Screen

Select one of the components to view hardware and software information. Press the “Home” button to return to the main screen.

Diagnostics*

The Diagnosis screen allows the operator to view the following diagnostic items:

- Active diagnostic codes
- Logged diagnostic codes
- Active event codes
- Logged event codes

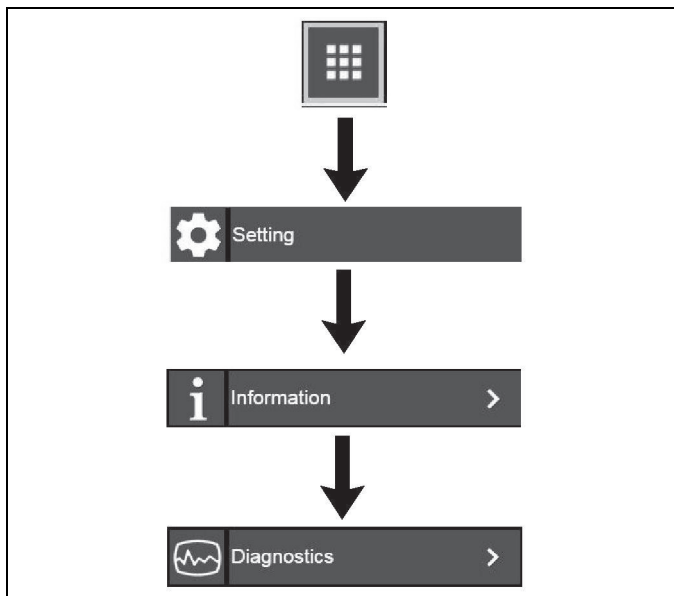

g06242064

Figure 6-106: Diagnostics Button

From the main screen, press the application menu button. In the application menu, select “Setting”. Next, select “Information” and then “Diagnostics”.

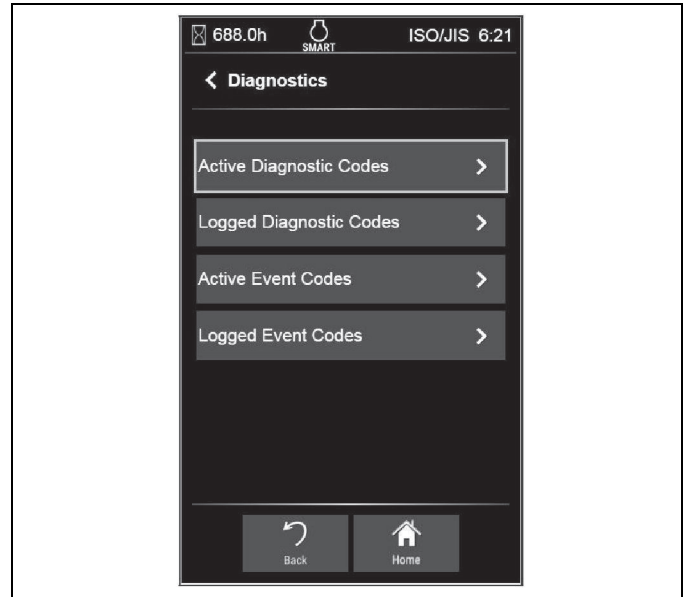

g06242065

Figure 6-107: Diagnostics Screen

Select from the groups of diagnostic codes to view active and logged codes. Press the “Home” button to return to the main screen.

Machine Setting*

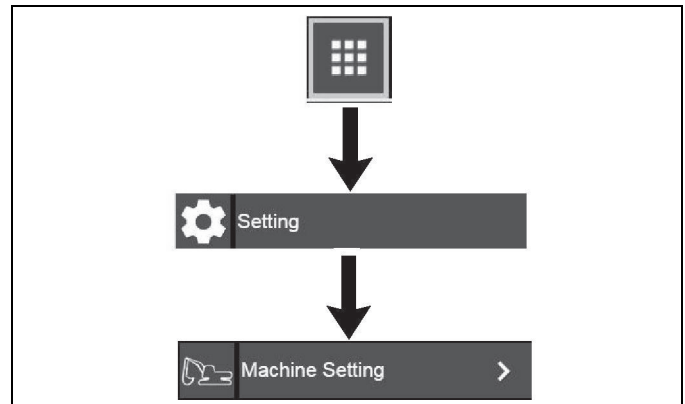

g06217583

Figure 6-108: Machine Setting Button

From the main screen, press the application menu button. In the application menu, select “Setting”. Next, select “Machine Setting”.



Figure 6-109: Machine Settings Menu

The Machine Settings menu contains the following menu items:

- Engine Shutdown Setting
- Power Mode Setting
- Reverse Fan
- Grade
- Payload
- Assist
- E-fence
- Audio
- Lighting Shutdown Timer
- Auto Warm Up
- Sleep Time
- Security

Engine Shutdown Setting*

NOTE: Master level access is required to adjust engine shutdown settings.

The Engine Shutdown Setting screen allows the operator to enable, disable, and adjust the engine shutdown timer. This feature operates the engine at idle speed for a set amount of time to cool the engine before shutting down automatically.

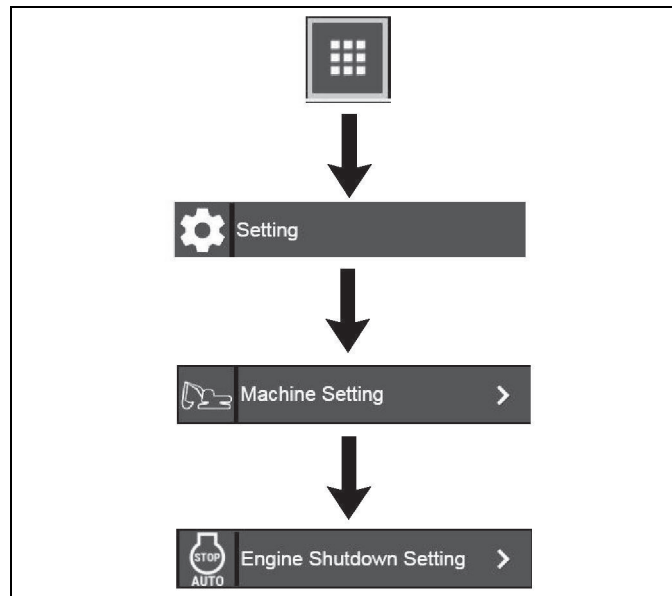

Figure 6-110: Engine Shutdown Setting Button

From the main screen, press the application menu button. In the Application menu, select “Setting”. Next, select “Machine Setting”, and then “Engine Shutdown Setting”.



Figure 6-111: Engine Shutdown Screen

Select “Idle Shutdown Enable” to enable or disable the idle shutdown feature. If enabled, select “Idle Shutdown Delay Timer” to change the delay time.

CONTROLS

Power Mode Setting*

NOTE: Master level access is required to adjust power mode settings.

The Power Mode Setting screen allows the operator to choose what power mode to operate the engine.

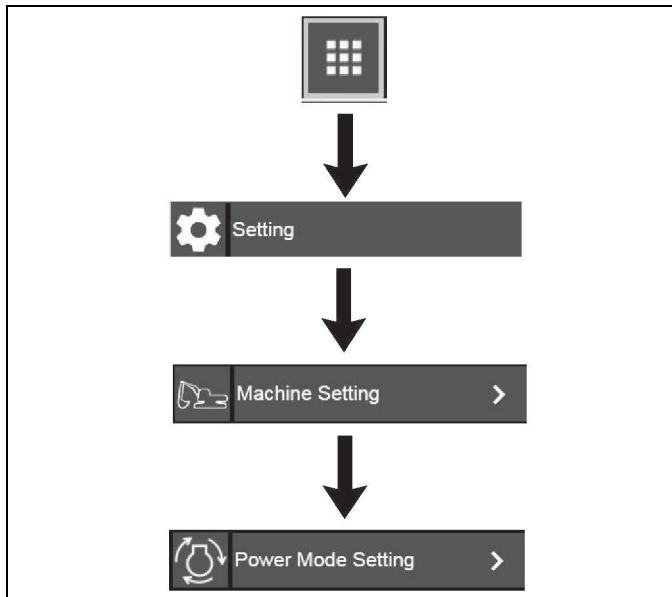

g06261309

Figure 6-112: Power Mode Setting Button

From the main screen, press the application menu button. In the application menu, select “Setting”. Next, select “Machine Setting”, and then “Power Mode Setting”.



g06225710

Figure 6-113: Power Mode Setting Screen

Select the desired power mode to operate in and switch to “ON”. The operator can also select the default power mode when the engine is first started. Once finished, press the “Home” button to return to the main screen.

Reverse Fan (If Equipped)*

NOTE: Master level access is required to adjust reverse fan settings.

The reversing fan feature allows the operator or maintenance personnel to reverse the fan to clean debris from the cooling group. The Reverse Fan screen allows the activation of the reverse fan feature.

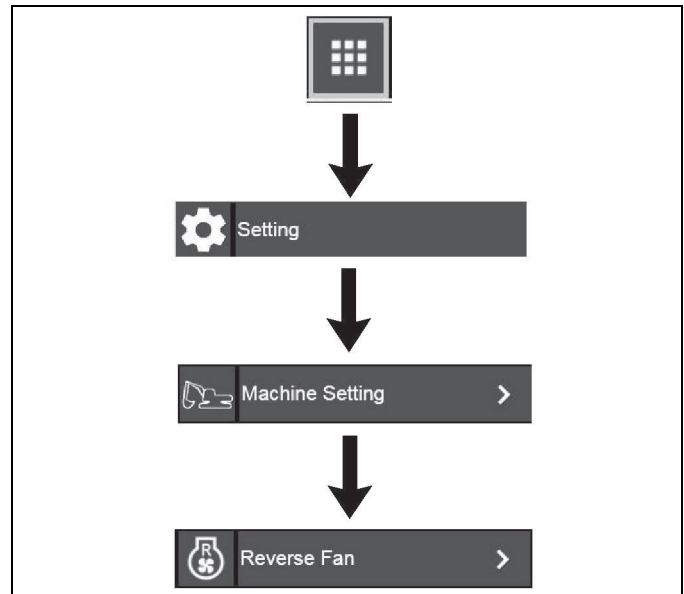

g06261312

Figure 6-114: Reverse Fan Button

From the main screen, press the application menu button. In the application menu, select “Setting”. Next, select “Machine Setting”, and then “Reverse Fan”.

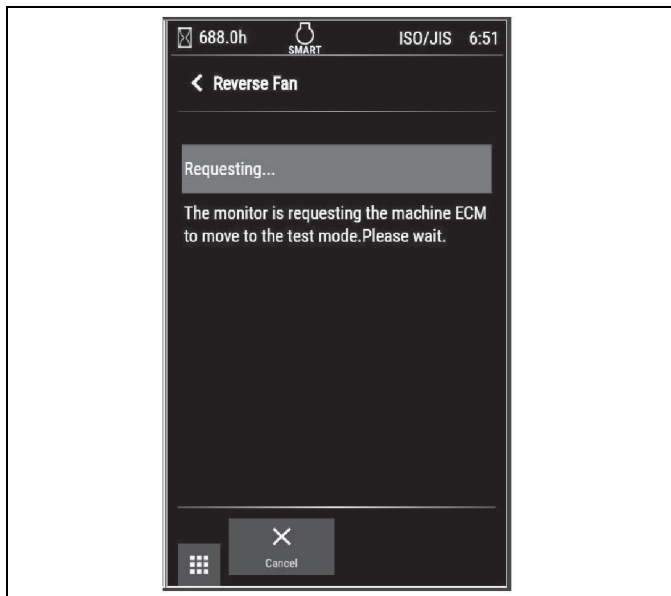

Figure 6-115: Reverse Fan Display

Follow the instructions and prompts on the monitor to reverse the fan.

Reverse Fan - Auto Mode*



Figure 6-116: Reverse Fan Screen

The reversing fan feature allows the operator or maintenance personnel to reverse the fan to clean debris from the cooling group. The Reverse Fan screen allows the activation of the reverse fan feature.

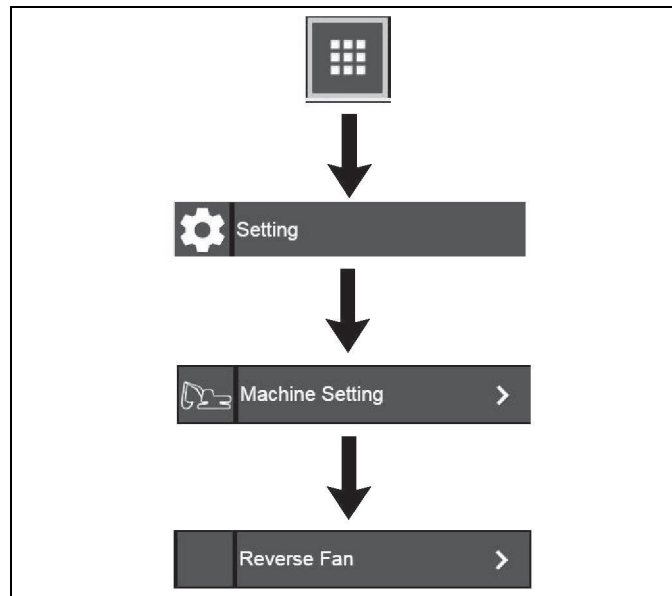

Figure 6-117: Reverse Fan Button

From the main screen, press the application menu button. In the application menu, select “Setting”. Next, select “Machine Setting”, and then “Reverse Fan”.



Figure 6-118: Auto Reverse Fan Button

CONTROLS

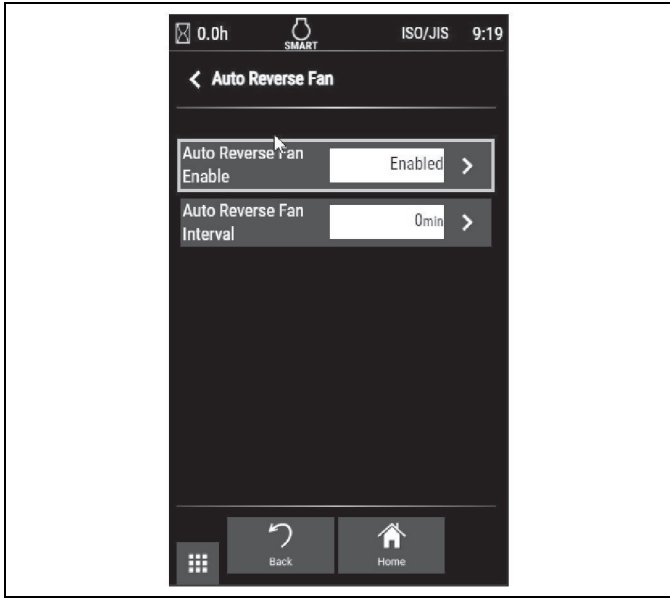

g06360013

Figure 6-119: Auto Reverse Fan Screen

Select “Auto Reversal Fan Enable” to enable or disable the idle Auto Reverse fan feature. If enabled, select “Auto Reverse Fan Interval” to set the interval time for auto reverse fan feature. Once finished, press the “Home” button to return to the main screen.

Audio*

The Audio screen allows the user to choose the radio region, enable Bluetooth, pair devices, and scan for Digital Audio Broadcast (DAB) channels.

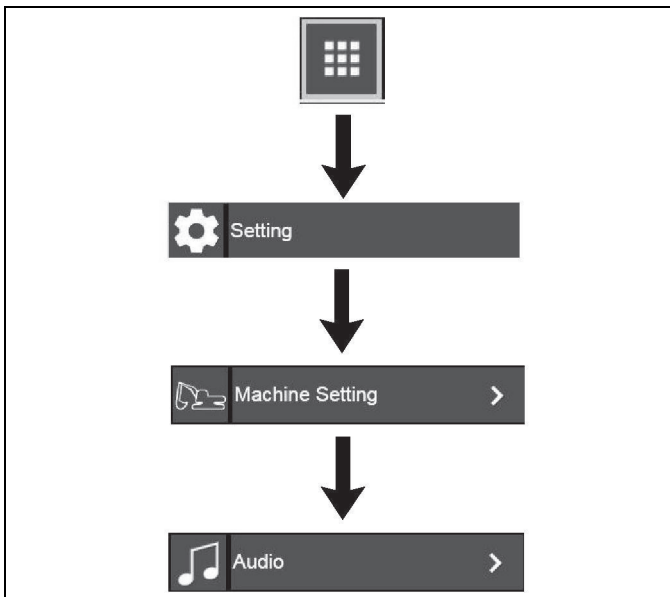

g06261319

Figure 6-120: Audio Button

From the main screen, press the application menu button. In the application menu, press “Setting”. Next, select “Machine Setting”, and then “Audio”.

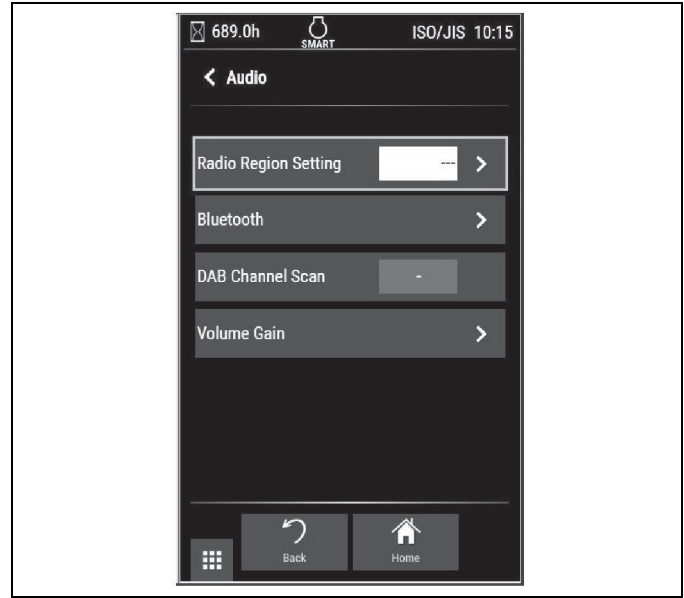

g06241515

Figure 6-121: Audio Screen

The Audio screen contains the following menu items:

- Radio Region Setting - Choose the radio region from the list of locations around the world.
- Bluetooth - Allows the operator to enable Bluetooth and pair a phone. This menu is also available through the main Audio screen. Refer to Operation and Maintenance Manual, Monitoring System - Bluetooth for information on the Bluetooth screen.
- DAB Channel Scan - Start a scan to find DAB channels in the area with good reception.
- Volume Gain - Allows the user to individually adjust the gain on various outputs such as the AM radio, FM radio, and the phone.

Lighting Shutdown Timer*

NOTE: Master level access is required to lighting shutdown settings.

The Lighting Shutdown Timer screen allows the user to enter a delay time for the exterior lights to shut off. The Lighting Shutdown Timer provides light for a set amount of time to allow the operator to safely dismount the machine.

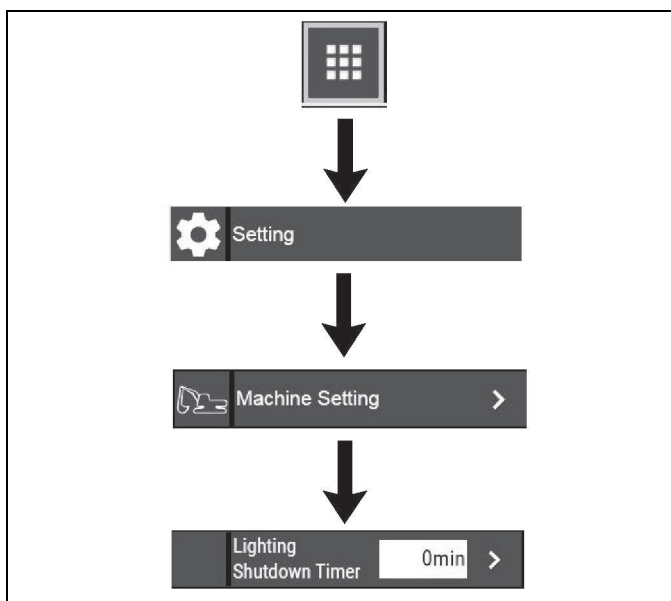

g06241072

Figure 6-122: Lighting Shutdown Timer Button

From the main screen, press the application menu button. In the application menu, select “Setting”. Next, select “Machine Setting”, and then “Lighting Shutdown Timer”.



g06241076

Figure 6-123: Lighting Shutdown Timer Screen

Use the keypad to enter the number of minutes for the light delay. Select “Apply” when done.

Auto Warm Up*

The Auto Warm Up screen allows the user to enable and set the auto warm-up feature. This feature automatically starts a warm-up period when the engine is started and the hydraulic oil is below the set temperature.

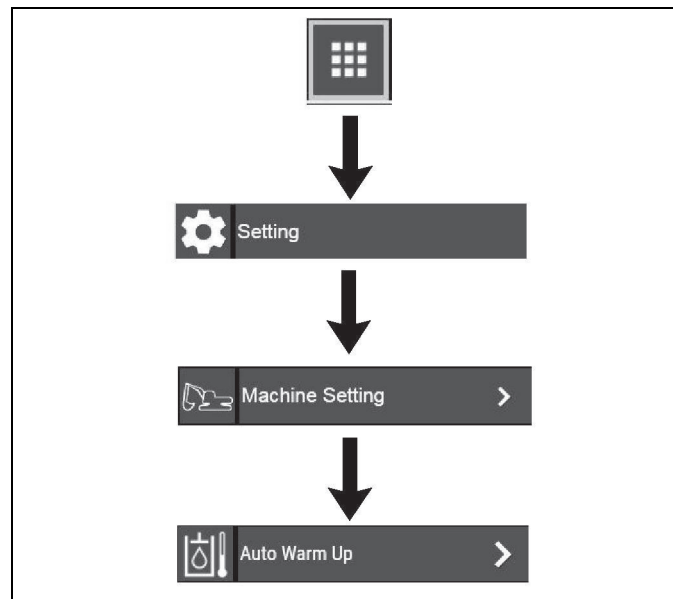

g06261321

Figure 6-124: Auto Warm Up Button

From the main screen, press the application menu button. In the application menu, select “Setting”. Next, select “Machine Setting”, and then “Auto Warm Up”.



g06220397

Figure 6-125: Auto Warm Up Screen

CONTROLS

To enable or disable auto warm-up, press the “Auto Warm Up Enable Status” window, then select “Enabled” or “Disabled”.

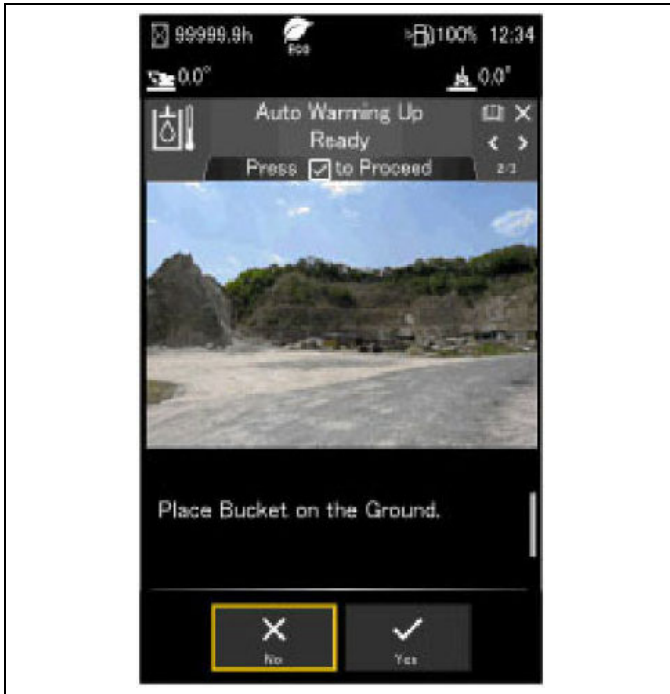

g06219830

Figure 6-126: Auto Warm Up Status Screen

To set the auto warm-up temperature, press the “Auto Warm Up Target Temp” window, then enter the temperature. If the hydraulic oil is below the set temperature, the auto warm-up feature will activate after the engine is started.

Sleep Time*

The Sleep Time setting feature allows the user to set a sleep timer for the engine start switch. If the start switch is left in the ON position, power will automatically shut off once the chosen timer interval has elapsed.

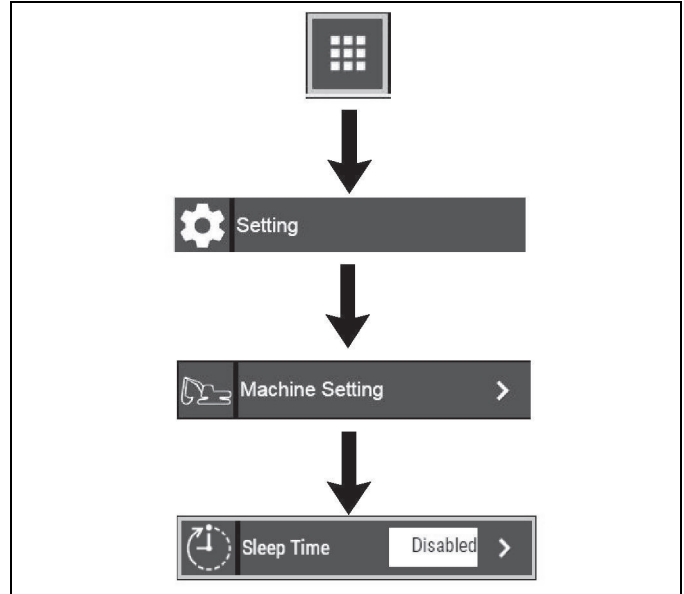

g06360104

Figure 6-127: Sleep Time Button

From the main screen, press the application menu button. In the Application menu, select “Setting”. Next, select “Machine Setting”, and then “Sleep Time”.



g06360101

Figure 6-128: Machine Setting Menu

Security*

NOTE: Master level access is required to adjust security settings.

The Security screen allows the user to set the operator lockout time. The lockout time is the amount of time after engine shutdown that an operator can start the engine without logging back in to the monitor.

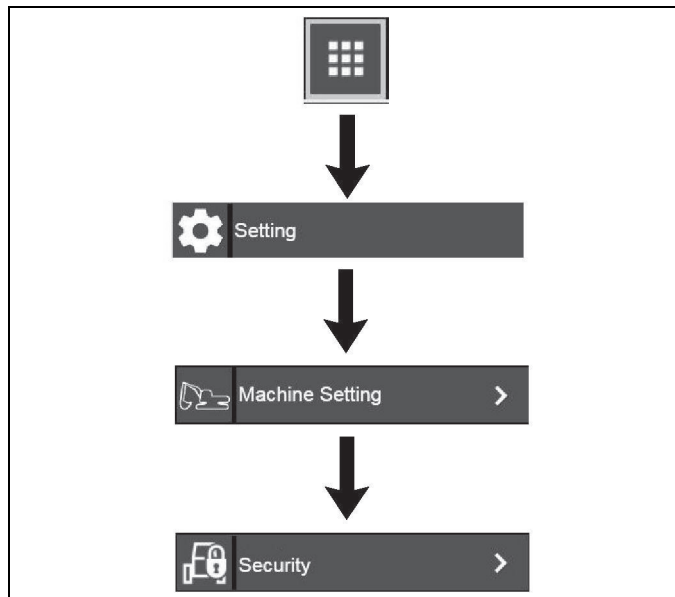

Figure 6-129: Security Button

g06261324

From the main screen, press the application menu button. In the Application menu, select “Setting”. Next, select “Machine Setting”, and then “Security”.



Figure 6-130: Operator ID Timeout Button

g06242069

Select “Operator ID Timeout” to select the amount of time before the operators passcode times out after engine shutdown. To block out periods of time throughout the week to bypass security, select “Security Bypass Time”.



Figure 6-131: Operator ID Screen

g06242071

Enter the times and the days to bypass the security system.

Operator Setting*

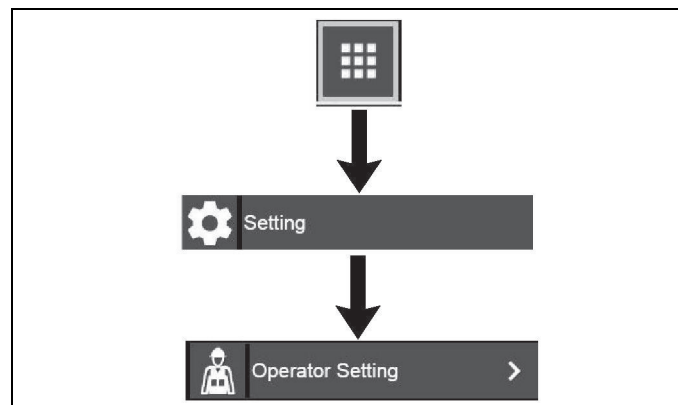

Figure 6-132: Operator Setting Button

g06217328

From the main screen, press the application menu button. In the Application menu, select “Setting”. Next, select “Operator Setting”.

CONTROLS



Figure 6-133: Operator Setting Menu

The Operator Setting menu contains the following menu items:

- Operator Inputs Configuration
- Response
- Change Operator
- Manage Operator

Operator Inputs Configuration*

The operator inputs configuration screen allows the operator to configure the joystick buttons for personal preference. The settings will be stored in the preferences for that login ID.

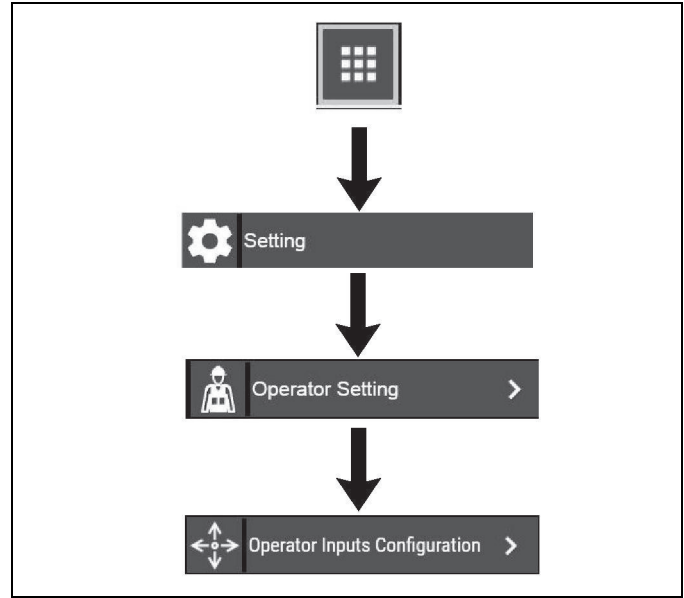

Figure 6-134: Operator Inputs Configuration Button

From the main screen, press the application menu button. In the application menu, select “Setting”. Next, select “Operator Setting”, then “Operator Inputs Configuration”.

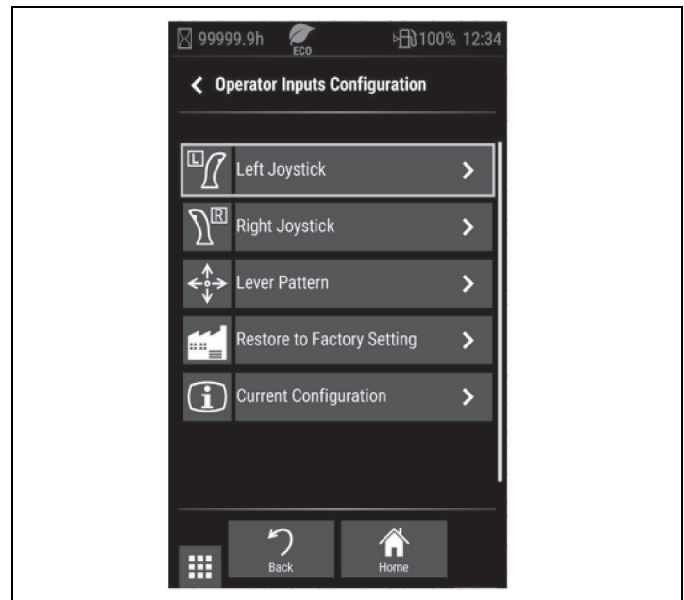

Figure 6-135: Operator Inputs Configuration Screen

Choose the joystick to configure.

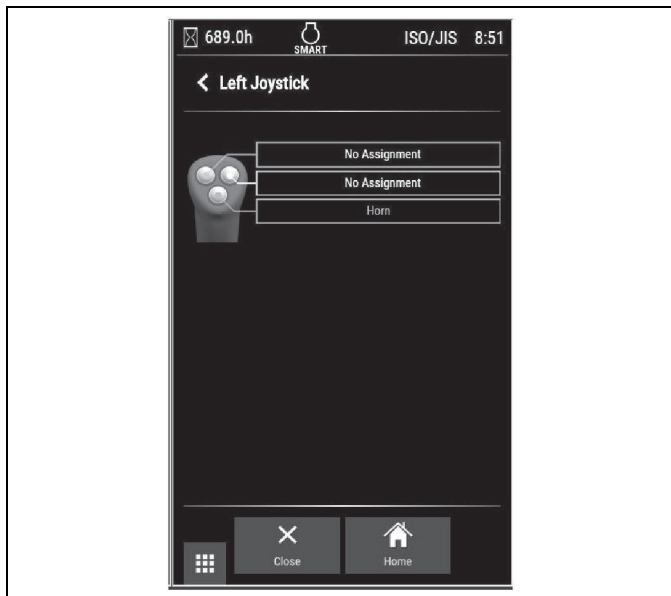

Figure 6-136: Joystick Settings

Select the button to configure.



Figure 6-138: Joystick Button Functions

Select the desired function from the list. Repeat for the remaining buttons and press the “Home” button to return to the main screen.



Figure 6-137: Joystick Button Selection

Select the category of button functions to choose from.

Change Operator*

The change operator screen allows a new operator to log in. After successfully logging in, the previous operators preferences will be overridden with the new operators preferences.

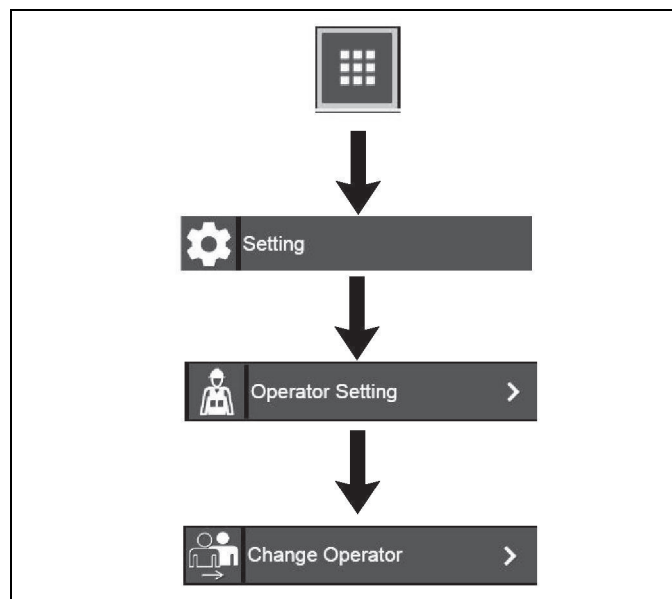

Figure 6-139: Change Operator Button

From the main screen, press the application menu button. In the Application menu, select “Setting”. Next, select “Operator Setting”, then “Change Operator”.

CONTROLS



Figure 6-140: Passcode Entry Screen

Enter the passcode or press the “Guest” button to log in as a guest.



Figure 6-141: New Operator Screen

If the login was successful, the operator screen will appear showing the preferences for the new operator. Press the “OK” button to return to the main screen.

Manage Operator*

NOTE: Master level access is required to manage operator settings.

The Manage Operator screen allows users to add and remove operators to the machine.

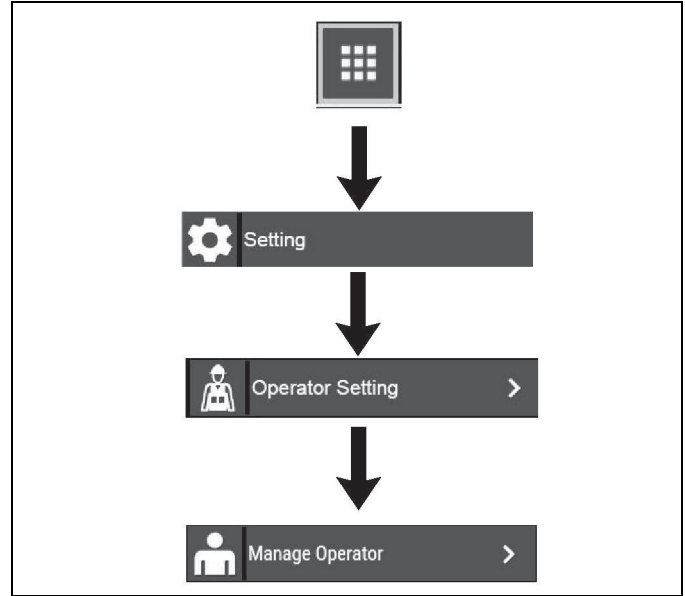

Figure 6-142: Manage Operator Button

From the main screen, press the application menu button. In the Application menu, select “Setting”. Next, select “Operator Setting”, then “Manage Operator”.

Add Operator*



Figure 6-143: Manage Operator Screen

In the Manage Operator screen, select “Add Operator”.



Figure 6-144: Add Operator Screen

Enter the key type, access level, operator name, and the key code for the new operator. Select the “Home” button to return to the main screen.

Edit/Delete Operator*



Figure 6-145: Operator List

To edit or delete an operator, scroll through the operator list in the Manage Operator screen and find the operator to be changed.



Figure 6-146: Operator Access Screen

To change the access level, select the window and change to either Master or Standard.

To edit the operator name, select the window and use the keyboard to change the name.

To delete the operator, select “Delete The Operator”.

Automatic Engine Speed Control (AEC)

When enabled, the Automatic Engine Speed Control (AEC) automatically reduces engine speed when the machine is inactive. The AEC system is designed to reduce fuel consumption and noise. Lower engine speeds can also increase engine life.

The engine rpm will recover automatically to the setting of the engine speed dial when any hydraulic function is activated.

CONTROLS

Table 30*

AEC State	Position of Manual Low Idle Switch	Description of Mode
Enabled	OFF	The electronic controller will automatically reduce the engine rpm after there has been no hydraulic demand for a set amount of time. The default time setting is 5 seconds. Approximate engine rpm: 320 GC - 950 rpm, All models except 320 GC - 1000 rpm.
Enabled or Disabled	ON	The engine speed is reduced. Approximate engine rpm: 320 GC - 950 rpm, All models except 320 GC - 1000 rpm.

NOTE: The position of the engine speed dial has no relevance on the actions described in Table 30.

Heavy Lift*

This work mode increases the relief pressure in the hydraulic circuit, which increases the hydraulic force that is available for lifting operations. The cylinder speed is slower when this mode is selected.

NOTE: During normal excavation work, the heavy lift control must be in the OFF position.

NOTICE

If this machine is used to lift objects within an area that is controlled by the European Directive "2006/42/EC", the machine must be equipped with a boom lowering control valve, a stick lowering control valve, and an overload warning device.

(*) M0080149-08 ©2022 Caterpillar All Rights Reserved

Chapter 7

Operation

Operating Safely

⚠️ WARNING

Before operating the drilling rig:

- Review the safety precautions described in Chapter 2 Safety.
- The operator must be trained in the use of this machine, or be guided by someone trained in its use.

Failure to follow these warnings may result in death or serious injury.

⚠️ WARNING

- A trained operator must be either operating the machine or assisting someone being trained to use the machine.
- Only use equipment, tools, and attachments authorized by CZM.
- Do not use the machine for any other purpose that what it was designed for. See “Authorized Use of This Drilling Rig” on page 2-38. Do not use the machine to lift people.
- If the operator view is obstructed, a signal person must observe and guide the operator.

Failure to follow these warnings may result in death or serious injury.

⚠️ CAUTION

- The main winch is only to be used for lifting and lowering the kelly bar and any attachments.
- The auxiliary winch is only to be used for lifting drilling equipment such as work tooling, pile equipment, pipe, and casings.

Use of the winches for lifting items for which they are not designed may result in damage to the machine.

Daily Inspections

Perform prestart inspections:

- Check the engine oil level, coolant fluid level, DEF level, fuel level, and hydraulic oil level.
- Inspect wire ropes for visible wear or damage.
- Inspect the undercarriage and mast for any damage, cracks, or loose and missing hardware.
- Inspect the main and auxiliary winch limit switches.
- Inspect the pin connections between crowd cylinders and the rotary.
- Inspect the mast articulation pin and safety pin.
- Inspect the counterweight bolts.

Mounting and Dismounting

For mounting and dismounting the machine, see “Access to the Drilling Rig” on page 2-33.

Cab Operation

Cab Door*

SMCS Code:7308



g06180275

Figure 7-1: Cab Door

To open the cab door from the outside of the cab, pull outward on the door handle.

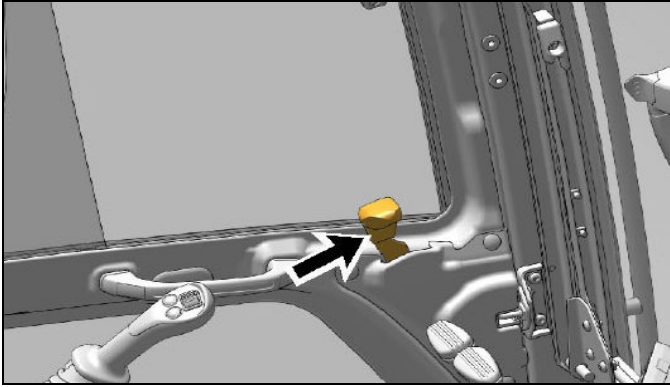

Figure 7-2: Cab Door Latch

To open the cab door while inside the cab, push forward on the lever for the cab door latch.

For additional ventilation, open the cab door all the way to engage the catch on the exterior wall of the cab.

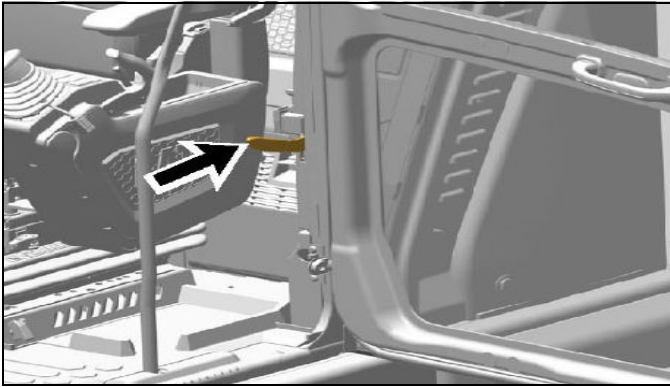

Figure 7-3: Cab Door Release Lever

To release the cab door from the catch, pull downward on the cab door release lever.

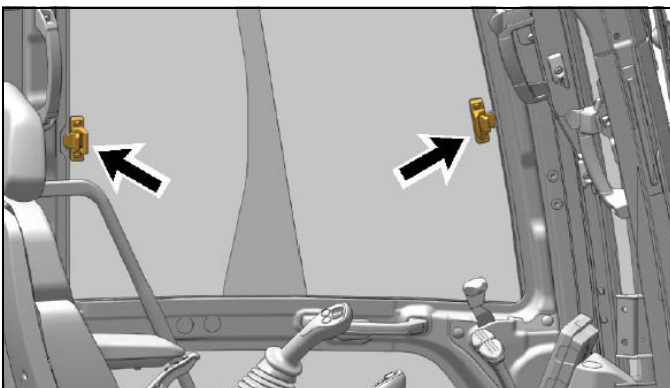

Figure 7-4: Window Latch

To open a window, release the window latch, and slide the window to the desired position.

Window (Front)*

To provide full ventilation inside the cab, the upper window and the lower window can be fully opened.

⚠WARNING

When opening or closing the windows, be extra careful to prevent any personal injury. The hydraulic lockout control must be in the LOCKED position to prevent any possibility of sudden movement of the machine due to inadvertent contact with the hydraulic control(s). Failure to follow this warning may result in serious injury or death.

Do not change the position of the window until the following items have been done:

- Park the machine on a level surface.
- Lower the work tool to the ground.
- Move the hydraulic lockout control to the LOCKED position.
- Stop the engine.

Perform these steps to open the upper window:

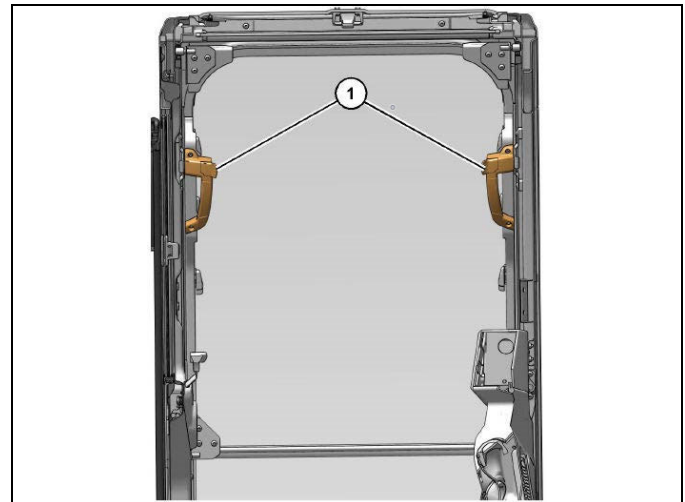

Figure 7-5: Cab-Front Window Levers

1. Release the auto-lock latches by pressing release levers (1) on the window handles.
2. Holding both handles on the window frame, pull the window upward.
3. Hold both grips that are provided on the window frame and move the window into the storage position until the auto-lock latches near the ceiling are engaged.

Once opened, perform these steps to close the upper window:

1. Release the auto-lock latches by pressing release levers (1) on the window handles.
2. Reverse Steps 1 through 3 to close the upper window.

Perform these Steps to open the lower window and close the lower window:

NOTICE

The lower window is curved. The lower window can only be positioned one way in the holders.

1. Raise the lower window out of the window frame.

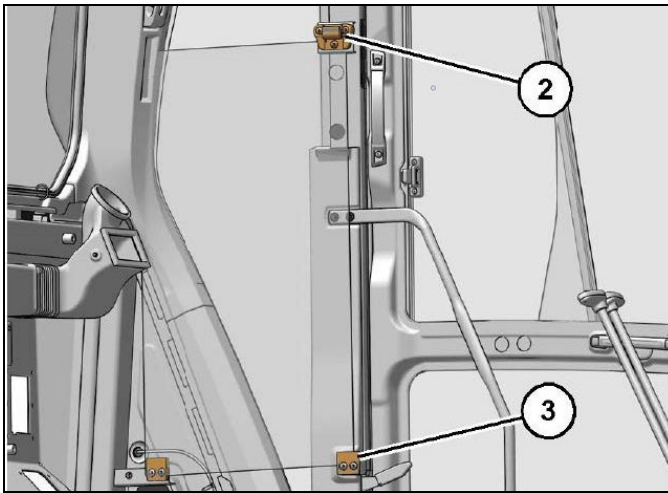

Figure 7-6: Lower Window

2. Store the lower window in the holder that is located in the rear of the left side cab frame. To store the lower window, place one end of the lower window into brackets (3). Secure the opposite end of the lower window with catch (2).
3. To close the lower window, reverse the procedure that is used for opening the lower window.

Alternate Exit*

SMCS Code: 7310

Rear Window with Ring Seal (If Equipped)*

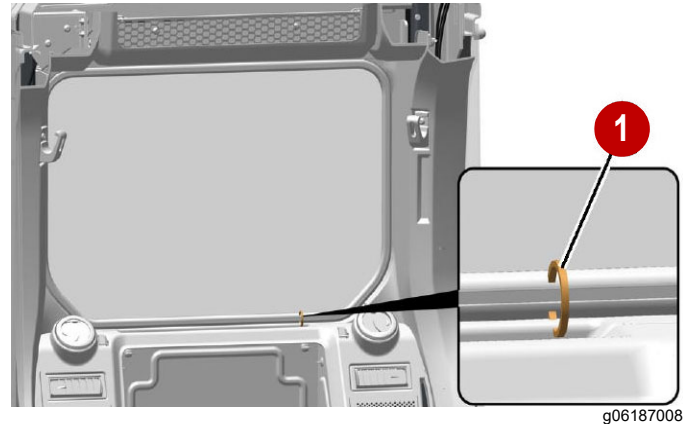

Figure 7-7: Rear Window – Pull Ring



Alternate Exit – The rear window serves as an alternate exit.

To remove the rear window, pull ring (1) and completely remove the window seal, then push out the glass. Climb through the rear window opening to exit the cab.

Rear Window with Lever (If Equipped)*

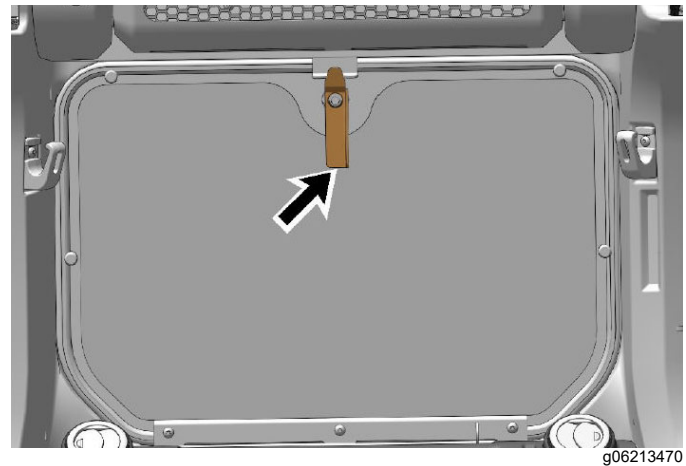

Figure 7-8: Inside Lever in Latched Position



Alternate Exit – The rear window serves as an alternate exit.

To remove the rear window, rotate handle from its latched position, then push out the glass. Climb through the rear window opening to exit the cab.



g06213471

Figure 7-9: Rear Window – Outside Handle

The window is also equipped with an outside handle. If the operator is unable, outside personnel can rotate the outside handle and pull the window out.

Roof Hatch*

⚠ WARNING

When opening or closing the windows, be extra careful to prevent any personal injury. The hydraulic lockout control must be in the **LOCKED** position to prevent any possibility of sudden movement of the machine due to inadvertent contact with the hydraulic control(s). Failure to follow this warning may result in serious injury or death.

⚠ CAUTION

Do not stand or walk on the hatch or the roof of the cab. Serious damage may occur.

Do not change the position of the window until the following items have been done:

- Park the machine on a level surface.
- Lower the work tool to the ground.
- Move the hydraulic lockout control to the **LOCKED** position.
- Stop the engine.

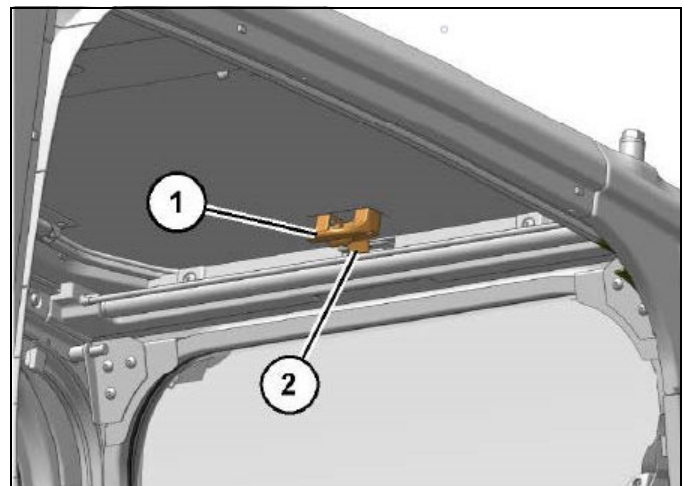

g06179871

Figure 7-10: Cab-Roof Hatch

To open the cab-roof hatch, release lock (2). Hold grip (1) and push the cab-roof hatch upward.

To close the cab-roof hatch, hold grip (1) and pull the cab-roof hatch downward. Engage lock (2) securely.

Sun Screen*

⚠ WARNING

When opening or closing the windows, be extra careful to prevent any personal injury. The hydraulic lockout control must be in the **LOCKED** position to prevent any possibility of sudden movement of the machine due to inadvertent contact with the hydraulic control(s). Failure to follow this warning may result in serious injury or death.

NOTICE

Do not change the position of the sun screen without performing the following actions:

- Park the machine on a level surface.
- Lower the work tool to the ground.
- Move the hydraulic lockout control to the **LOCKED** position.
- Stop the engine.

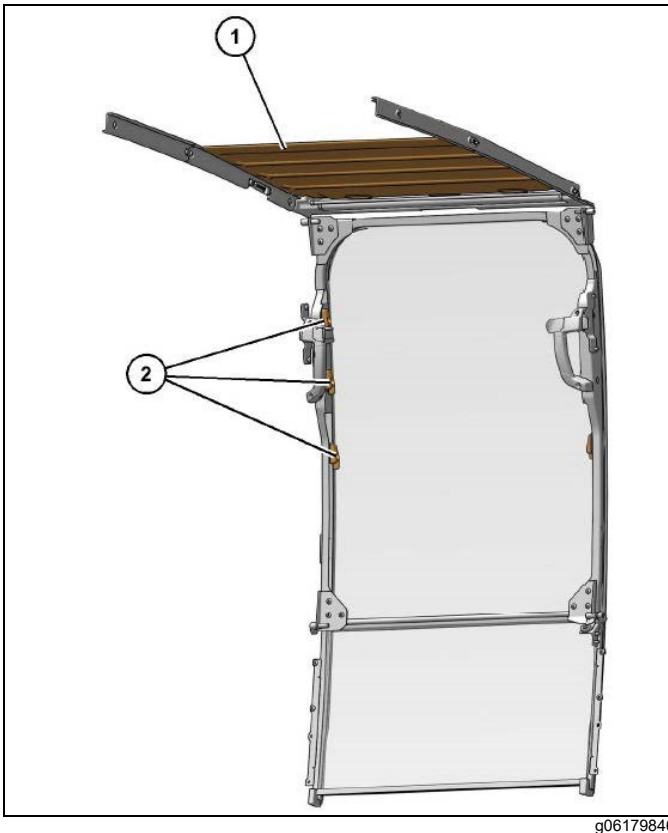
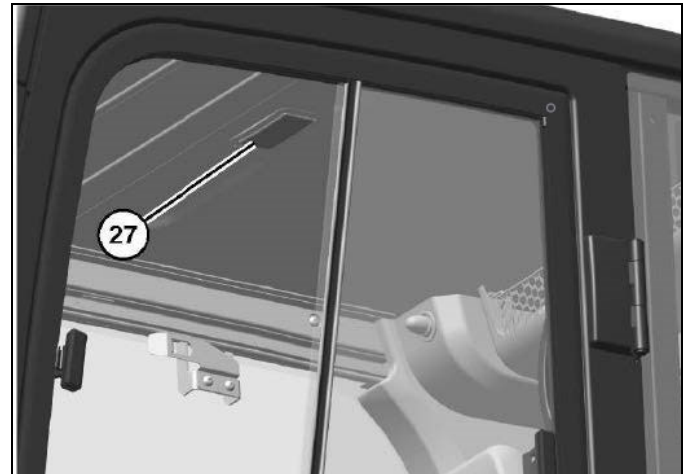

Figure 7-11: Window-Sun Screen

1. Pull the sun screen (1) down from the ceiling.

2. Hook the sun screen to the brackets (2) at both sides of the front window.
3. The sun screen may be positioned at two different heights.

Dome Light*



g06208645

Figure 7-12: Cab-Dome Light

The dome light (27) has three different positions.

When the dome light is in the center position (horizontal), the light will come on when the door is open and shut off when the door is closed.

When the left side of the dome light is pressed, the light will be inoperable. When the right side of the dome light is pressed, the light will turn on and stay on.

Product Link*

SMCS Code: 7490; 7606

Note: Your machine may be equipped with the CAT® Product Link™ system.

The Cat Product Link communication device utilizes cellular and/or satellite technology to communicate equipment information. This information is communicated to Caterpillar, Cat dealers, and Caterpillar customers. The Cat Product Link communication device uses Global Positioning System (GPS) satellite receivers.

The capability of two-way communication between the equipment and a remote user is available with the Cat Product Link communication device. The remote user can be a dealer or a customer.

OPERATION

Visibility

⚠ WARNING

Before starting the machine, check that you have the correct visibility around the machine. Failure to follow this warning could result in death or serious injury.

Mirrors*

⚠ WARNING

Adjust all mirrors before operating the machine. Failure to follow this warning could result in death or serious injury.

NOTE: Some machines may not be equipped with all the mirrors that are described in this topic.

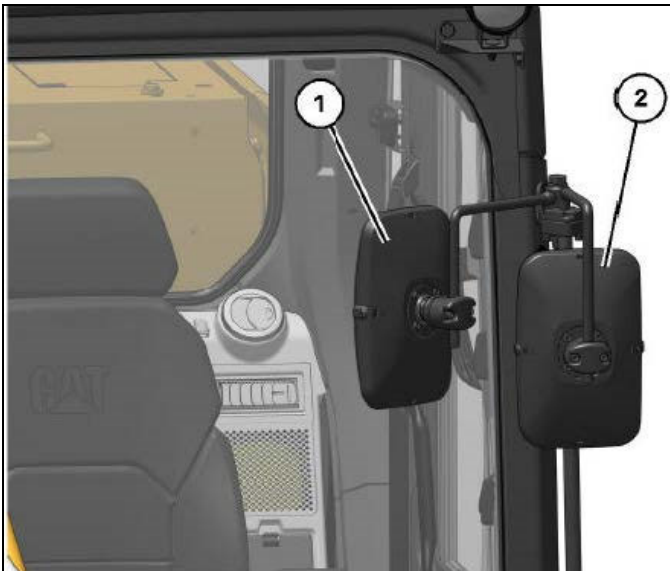

g06220616

Figure 7-13: Mirrors-Cab Right and Left Side View

- 1) Right side view mirror on the cab
- 2) Left side view mirror on the cab

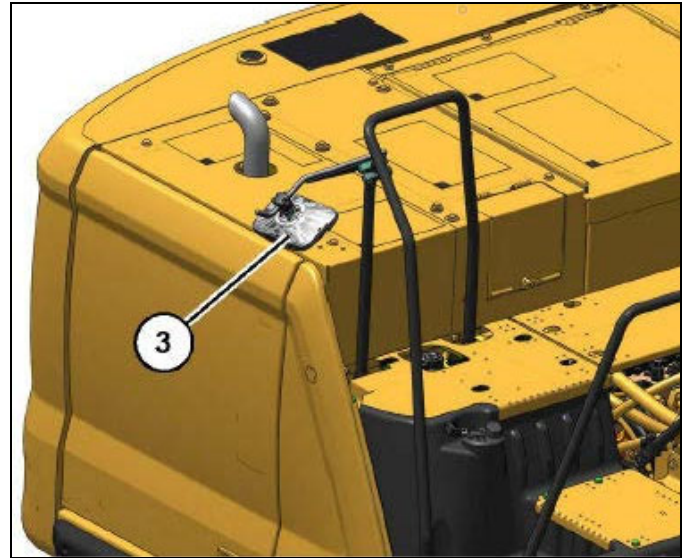

g06220627

Figure 7-14: Mirrors-Tank

3) Tank mirror

Mirrors provide additional visibility around the machine. Make sure that the mirrors are in proper working condition and that the mirrors are clean.

Adjust all mirrors at the beginning of each work period and adjust the mirrors when you change operators.

Modified machines or machines that have additional equipment or attachments may influence your visibility.

Mirror Adjustment

- Park the machine on a level surface.
- Lower the work tool to the ground.
- Move the hydraulic lockout control to the LOCKED position. For further details on this procedure, refer to "Hydraulic Lockout Control*" on page 6-7.
- Stop the engine.
- Adjust rear view mirrors to provide visibility behind the machine at a maximum distance of 30 m (98 ft) from the rear corners of the machine.

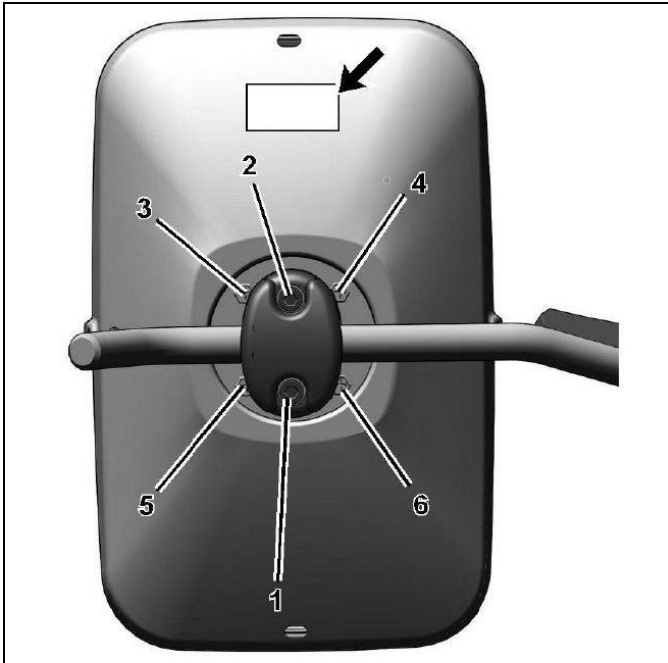

g06220634

Figure 7-15: Mirrors-Tightening Sequence

After adjustment of the mirror angle, make sure that the CAT® logo is at the top. It may be necessary to periodically tighten the mirror mounting bolts. If the bolts are loose, tighten the bolts in the sequence shown in Figure 186. Tighten bolts (1) and (2) to $11 \pm 2 \text{ N}\cdot\text{m}$ ($8.1 \pm 1.5 \text{ lb ft}$). Tighten the bolts (3) through (6) to $2 \pm 0.4 \text{ N}\cdot\text{m}$ ($1.5 \pm 0.3 \text{ lb ft}$).

Right Side View Mirror on the Cab (1)*

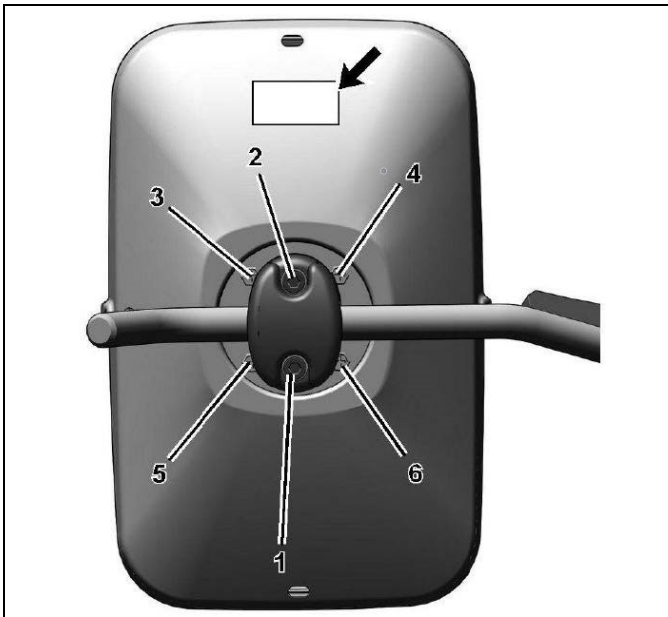

g06220634

Figure 7-16: Right Side View Mirror

If equipped, adjust the right side view mirror on the cab (1) so the front of the right track can be seen from the operator's seat.

A view of at least 1 m (3.3 ft) from the right front of the machine should be seen from the operator's seat.

Left Side View Mirror on the Cab (4)*

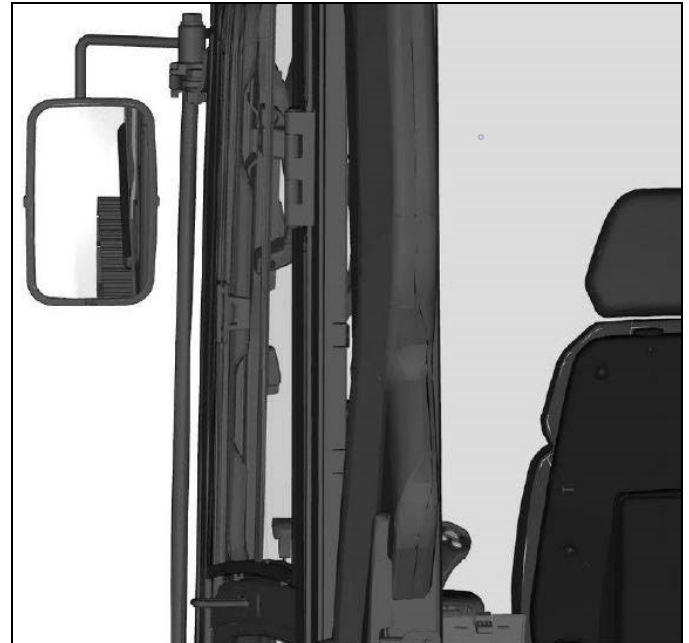

g06223279

Figure 7-17: Left Side View Mirror

If equipped, adjust the left side view mirror on the cab so the left side of the cab, access door, and rear of left track can be seen from the operator's seat.

A view of at least 1 m (3.3 ft) from the side of the machine should be seen from the operator's seat.

Additionally, provide as much visibility to the rear as possible.

OPERATION

Tank Mirror (3)*



g06223284

Figure 7-18: Tank View Mirror

If equipped, adjust the tank mirror so the fuel tank and the hydraulic tank can be seen from the operator's seat.

A view of at least 1 m (3.3 ft) from the side of the machine should be seen from the operator's seat.

Cameras*

Rear View Camera



g06184579

Figure 7-19: Camera-Rear View Camera

NOTE: The camera system has been set up at the factory or by a CAT® dealer to provide views that comply with specified guidelines. Consult your CAT® dealer before any adjustments are made to the system. For more information refer to "CAT® Monitoring System*" on page 6-29.

Side View Camera (If Equipped)*

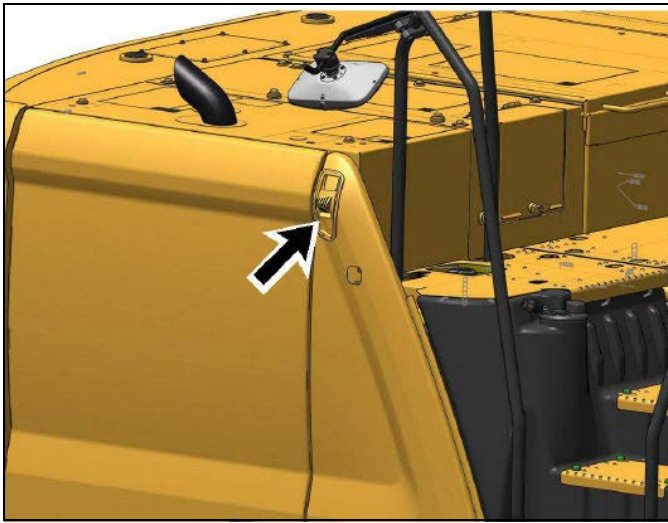

g06214504

Figure 7-20: Camera-Side View Camera

The side view camera system consists of a camera mounted on the panel next to the pump compartment.

NOTE: The camera system has been set up at the factory or by a CAT® dealer to provide views that comply with specified guidelines. Consult your CAT® dealer before any adjustments are made to the system. For more information refer to “CAT® Monitoring System*” on page 6-29.

360 Visibility (If Equipped)*

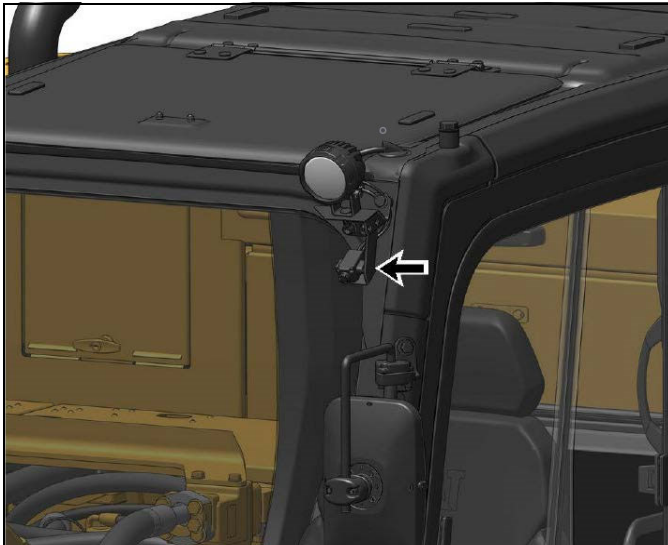

g06263449

Figure 7-21: Camera-360 Visibility-Front



g06263435

Figure 7-22: Camera-360 Visibility-Left Side

If equipped with the optional side and front cameras, the 360 visibility feature can be toggled On or Off to enable or disable the 360-degree visibility view in the monitor.

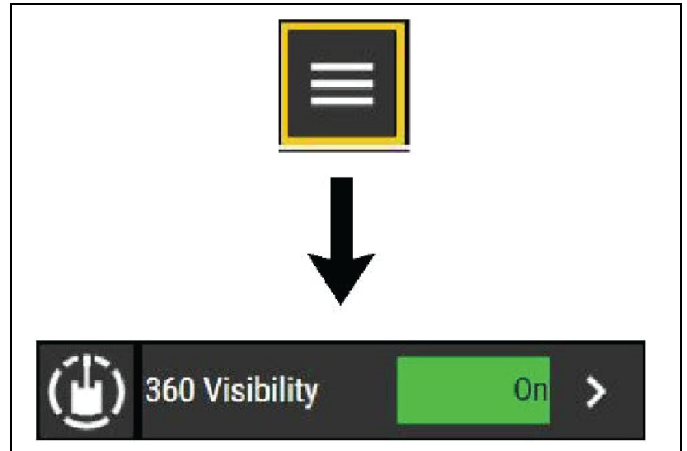

g06263096

Figure 7-23: Camera-360 Visibility

From the main screen, press the Function List icon. In the Function List menu, select “360 Visibility”.

NOTE: The camera system has been set up at the factory or by a CAT® dealer to provide views that comply with specified guidelines. Consult your CAT® dealer before any adjustments are made to the system. For more information refer to “CAT® Monitoring System*” on page 6-29.

OPERATION

Fuel Transfer Pump (Refueling) (If Equipped)*

SMCS Code: 1256

Use the following procedure to pump fuel and store the suction hose.

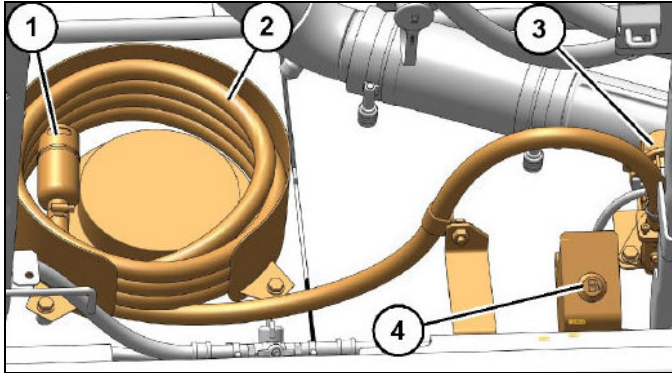

Figure 7-24: Fuel Transfer Pump

- (1) Suction valve
- (2) Suction hose
- (3) Electric refueling pump
- (4) ON/OFF switch



ON/OFF Switch – Push the ON/OFF switch to activate or deactivate the fuel transfer pump. A red indicator light on the switch will illuminate when the fuel transfer pump is activated.

If one of the following conditions occur, the fuel transfer pump will not activate and/or stop operating:

- Battery disconnect switch is in the OFF position.
- Engine is operating.
- Engine start switch is moved to the START position.
- Engine start switch is in the OFF position.
- Hydraulic lockout control is not in the LOCKED position.
- Fuel tank level is full.
- Fuel is not detected at the suction valve.
- 30 seconds following a detection of no fuel at the suction valve.

Use the following procedure to pump fuel and store the hose.

1. Park the machine on a level surface. Move the hydraulic lockout control to the LOCKED position. Stop the engine.

2. Turn the engine start switch to the ON position without starting the engine.
3. Remove the fuel tank cap from the fuel tank.
4. Open the right side access door.

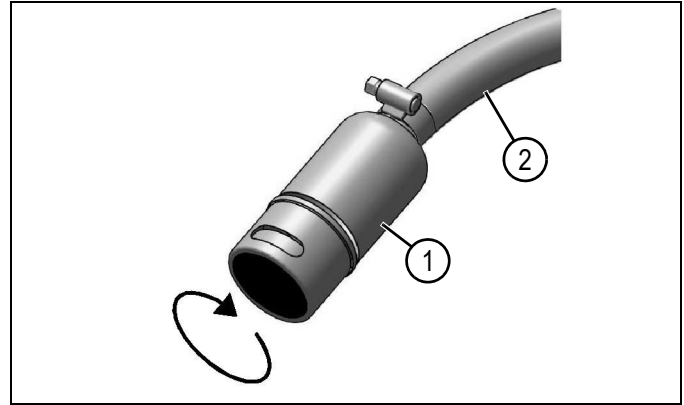

g06180748

Figure 7-25: Suction Valve

The suction valve (1) is located at the end of hose (2).

5. Uncoil the suction hose and turn the end of the suction valve clockwise to open the suction valve.
6. Properly insert the end of the suction valve into a container of fuel.
7. Push the switch (4) to activate the fuel transfer pump and supply the fuel to the tank. A red indicator light on the switch will illuminate when the fuel transfer pump is activated.

When the fuel tank is full, the fuel transfer pump will automatically stop.

When the fuel container is empty, push the switch again to stop refueling. If additional fuel is needed, wait 30 seconds and return to step 6.

NOTE: The red indicator light on the switch will turn off when the fuel transfer pump has stopped refueling.

NOTE: The fuel transfer pump will not activate for 30 seconds following a detection of no fuel at the suction valve.

8. Push the switch at any time to deactivate the fuel transfer pump.

NOTE: The red indicator on the switch will no longer illuminate when the fuel transfer pump has stopped refueling.

9. Drain excess fuel from the suction hose and turn the end of the suction valve counter-clockwise to close the suction hose valve.

Wind the suction hose and store in the hose container.

IMPORTANT

To prevent hose damage, do not coil the suction hose in a tight radius.

10. Close the access door.
11. Install the fuel tank cap onto the fuel tank.
12. Turn the engine start switch to the OFF position.

Fuel Tank Shutoff and Drain Control*

SMCS Code:1273

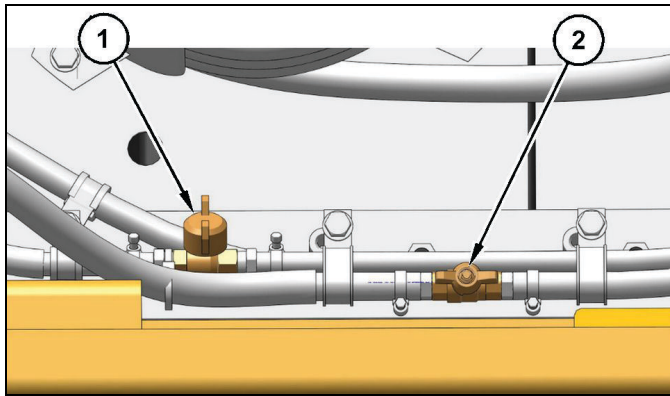

g06214473

Figure 7-26: Fuel Tank Drain Valve and Shutoff

Fuel Tank Drain Valve (1) – The drain valve for the fuel tank is located behind the right side access door.

To drain the water and sediment from the fuel tank, turn the fuel drain valve counterclockwise. To close the fuel tank drain valve, turn the drain valve clockwise.

Fuel Tank Shutoff Valve (2) – The fuel shutoff valve is located behind right side access door. To shut off the fuel supply, turn the fuel shutoff valve clockwise. To turn on the fuel supply, turn the fuel shutoff valve counterclockwise.

Engine Fuel Shutoff Valve

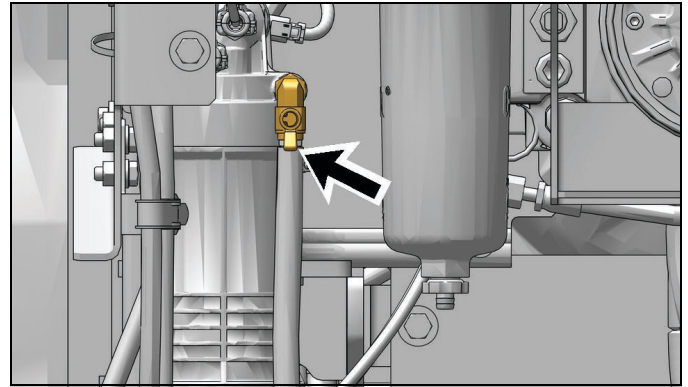

g06426077

Figure 7-27: Engine Fuel Shutoff Valve

The fuel shutoff valve is located behind the right access door. Shut off the fuel supply by turning the fuel shutoff valve clockwise.

OPERATION

Operation Information*

Make sure that no personnel are on the machine or near the machine to prevent any personal injury. Keep the machine under control at all times to prevent injury.

Reduce the engine speed when you maneuver the machine in tight quarters and when you drive over an incline.

1. Adjust the operator seat.
2. Fasten the seat belt.
3. Turn the engine speed dial to the desired operating range.



Figure 7-28: Engine Speed Dial

4. Move the hydraulic lockout control to the UNLOCKED position.

Undercarriage

NOTICE

Before moving the machine, check the position of the undercarriage. The normal travel position is with the idler wheels to the front under the cab and the drive sprockets to the rear. When the undercarriage is in the reversed position, the directional controls must be operated in opposite directions.

Traveling

When moving the machine:

- Sound the horn and allow adequate time for bystanders to clear the area before moving the machine into a restricted visibility area. Follow local practices for your machine application. For more information, refer to “Danger Zone” on page 2-37.
- Allow the engine and hydraulic oil to warm up before moving the machine.
- Select the necessary travel speed range before you drive downgrade. Do not change the travel speed range while traveling on a downgrade.

- Use the same travel speed on a downgrade and on an upgrade.
- Undercarriage tracks must be fully extended.
- Do not swing the upperstructure while traveling.
- Watch the clearance of the mast. Uneven ground can cause the machine to bounce.
- Rotary, work tool, and mast must be in the lowest horizontal position when traveling.
- Do not travel with the mast tilted.
- Do not move the mast while traveling.
- Do not travel with a suspended load.
- Avoid sudden movements.
- Before traveling consult **Chapter 3, “Stability”**.
- Clear all personnel and obstacles from the machine's path.
- Ask for the help of a ground assistant.
- Make sure all cab and compartment doors are closed and secured.
- Be sure that all windows are clean and secured.
- Adjust mirrors as required for best visibility.
- Fasten the seat belt.

Base Swinging

⚠ DANGER

Make sure that the area is clear of personnel and equipment.

- Swing the base slowly and smoothly.
- Swing the base only with the mast in the vertical position.
- Do not swing the base with the mast in the horizontal position.
- Do not lower the mast while the base is swung.
- Do not swing the base if the counterweight is disassembled.
- Do not swing the base if the track is not extended.
- Only swing the base with the track extended.

Failure to follow these instructions will cause death or serious injury.

Winches

DANGER

- The use of damaged or improperly installed wire rope is dangerous.
- Improper use of winches can result in a tip over.

Failure to follow the proper safety precautions will result in death or serious injury.

To avoid accidents:

- Inspect the wire ropes according to the instructions in this manual.
- Replace the wire ropes if they are damaged or worn.
- Make sure the assembly and fastening of the wire ropes is correct.
- Make sure the winding and unwinding of the wire rope on the drum is regular and without slack. Looseness can cause damage to the wire rope.

Main Winch

DANGER

Improper use can cause a tip over:

- Only use the main winch to raise and lower the drilling equipment inside the hole.
- Only use the main winch to raise and lower the drilling equipment along the vertical axis of the mast.

Failure to follow the proper safety precautions will result in death or serious injury.

Auxiliary Winch

DANGER

Improper use can cause a tip over.

Make sure you have read and understood the following sections:

- See “Auxiliary Winch” on page 1-10.
- See “Auxiliary Winch Safety” on page 2-46.
- See “Auxiliary Winch” on page 4-1.

Failure to follow the proper procedures will result in death or serious injury.

OPERATION

Starting the Machine

Selective Catalytic Reduction Warning System*

SMCS Code: 1091-WXX; 7400

The selective catalytic reduction (SCR) system is a system used to reduce NOx emissions from the engine. Diesel exhaust fluid (DEF) is pumped from the DEF tank and is sprayed into the exhaust stream. The DEF reacts with the SCR catalyst to reduce NOx and leaves a nitrogen and water vapor. The Exhaust Gas Recirculation (EGR) system cools, measures, and introduces recalculated exhaust gas into the intake manifold to aid in NOx reduction.

NOTICE

Stopping the engine immediately after the engine has been working under load can result in overheating of SCR components.

Refer to the Operation and Maintenance Manual, “Engine Stopping” procedure to allow the engine to cool and to prevent excessive temperatures in the turbocharger housing and the DEF injector.

NOTE: With the operator key in the OFF position, the purge system will activate.

Definitions

Observe the following definitions.

Self-correct – Fault condition no longer exists. An active fault code will no longer be active.

Notification – Action taken by the system to alert the operator of pending Inducement.

Inducement – Engine derates, vehicle speed is limited, or other actions intended to prompt the operator to repair or maintain the emission control system.

Inducement Trigger – Fault conditions that result in activation of the inducement strategy. DEF level inducement faults have a diagnostic fault code. DEF quality fault, SCR tampering fault, SCR system fault, and EGR system faults will all have a related diagnostic fault code along with an inducement diagnostic fault code.

First Occurrence – A DEF quality fault, SCR tampering fault, SCR system fault, or an EGR system fault becomes active for the first time.

Repeat Occurrence – If any DEF quality fault, SCR tampering fault, SCR system fault, or an EGR system fault becomes active again within 40 hours of the first occurrence.

Safe Harbor Mode – Safe harbor mode is a 20 minute engine run time period. The engine can be operated with full power after reaching a level 3 inducement. Once in level 3 inducement, the operator can perform a key cycle and the engine will enter safe harbor mode. Safe harbor mode can only be implemented once. Safe harbor mode is not allowed for DEF level inducements.



g06223861

Figure 7-29: DEF Level Normal

Inducement Strategy for DEF Level*

If multiple warnings are present in the system, the most important problem is shown first. Press the right key or press the left key to view all the warnings that are present in the machine. If no keys are pressed within 5 seconds, the display will return to the most important problem.

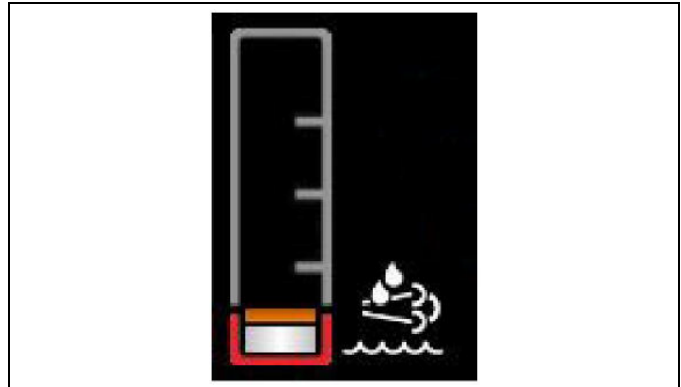

g06223864

Figure 7-30: DEF Level Low

If the DEF level falls below 19%, “DEF Level Low” message will be displayed on the monitor. To avoid further inducements, turn the key to the OFF position and add DEF to the DEF tank.

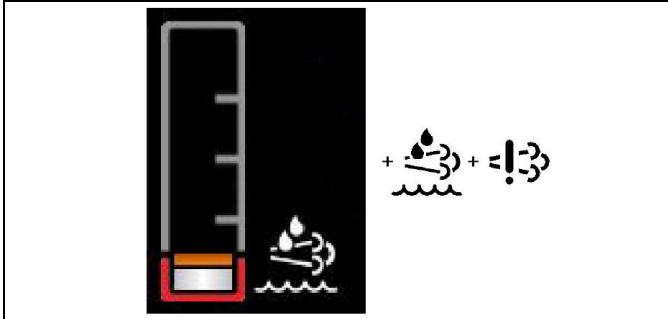

g06223865

Figure 7-31: DEF Level Low and Emission Fault

If the DEF level falls below 12.5%, a level 1 inducement event will occur. a “DEF Level Low” message and an “Emission Fault” message will appear on the monitor.

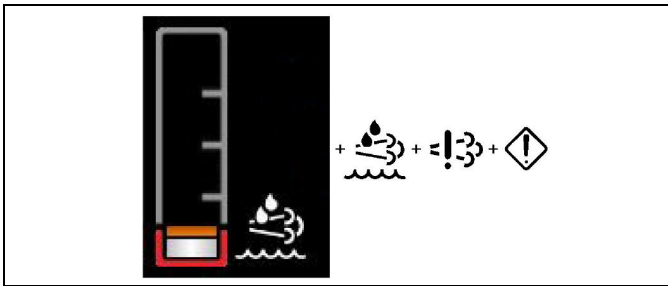

g06223866

Figure 7-32: DEF Level Low, Emission Fault, and Flashing Action Lamp

If the DEF level is below 6%, a level 2 inducement event will occur. A “DEF Level Low” message and an “Emission Fault” message will appear on the monitor. The action lamp on the monitor will flash. If the ECM is configured to “Reduced Performance” and the DEF level has reached 0%, the machine will be limited to 75% torque.

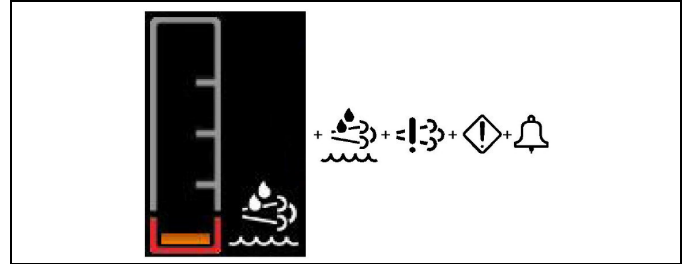

g06223883

Figure 7-33: DEF Level Low, Emission Fault, Flashing Action Lamp, and Audible Alarm

If the ECM is configured to “Reduced Performance” and the DEF tank has been emptied of all DEF, the engine will be in a level 3 final inducement. If the ECM is configured to “Reduced Time” and the DEF level is 0%, the engine will be in a level 3 final inducement. Prior to final inducement a “DEF Level Low” message, and an “Emission Fault” message will appear on the monitor. The action lamp on the monitor will flash and an audible alarm will sound 20 seconds prior to the final inducement. The engine will be taken to low idle or will be shut down. Once shut down, the engine can be restarted for 5 minute periods at reduced speed and torque. If set to idle, the engine will idle indefinitely at reduced torque. The amber indicator next to the DEF level gauge on the dash will remain lit.

NOTE: Turn the key to the OFF position and add DEF to the DEF tank to reset the DEF level inducement.

OPERATION

Inducement Strategy for DEF Quality, Tampering, SCR System Fault, and Impeded EGR*

If multiple warnings are present in the system, the most important problem is shown first. Press the right key or press the left key to view all the warnings that are present in the machine. If no keys are pressed within 5 seconds, the display will return to the most important problem.

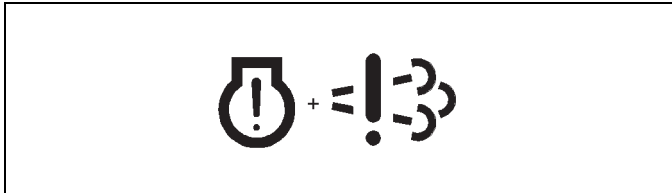

g03623190

Figure 7-34: Emission Fault

A “Engine Fault Check Engine” message and an “Emission Fault” message will appear on the monitor for a fault resulting from poor DEF quality, SCR system tampering, SCR system fault, or an EGR system fault. If the fault is the result of poor DEF quality, SCR system tampering, or SCR system fault, a first occurrence will result in a level 1 inducement for a duration of 2.5 hours. The level 1 inducement will also illuminate the check engine lamp. Repeat occurrences will result in a level 1 inducement duration of 5 minutes. If the fault is the result of an EGR system fault, a first occurrence will result in a level 1 inducement for a duration of 35 hours. Repeat occurrences will result in a level 1 inducement duration of 48 minutes.

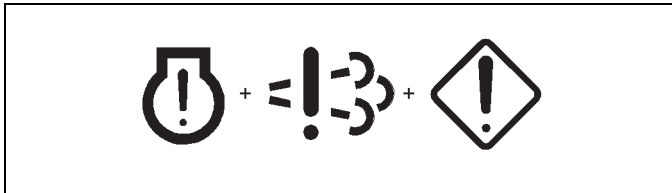

g03623191

Figure 7-35: Emission Fault and Message

If a fault condition exists for the entire duration of inducement level 1, the strategy advances to inducement level 2. A “Engine Fault Check Engine” message, and an “Emission Fault” message will appear on the monitor and the action lamp on the monitor will flash for a fault resulting from poor DEF quality, SCR system tampering, SCR system fault, or an EGR system fault. For poor DEF quality, SCR system tampering, and SCR system faults,

the duration for a level 2 inducement is 70 minutes for the first occurrence. For EGR system faults, the duration for a level 2 inducement is 60 minutes for the first occurrence. Repeat occurrences for poor DEF quality, SCR system tampering, and SCR system faults will result in a level 2 inducement of 5 minutes. Repeat occurrences for EGR system faults will result in a level 2 inducement of 60 minutes.

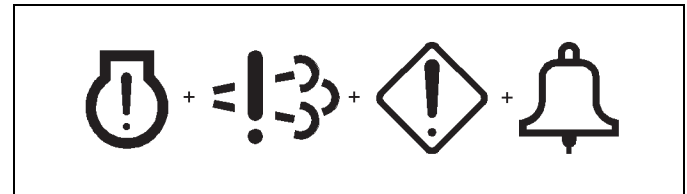

g03623193

Figure 7-36: Emission Fault, Message, and Alarm

If a fault condition exists for the entire duration of inducement level 2, the strategy advances to inducement level 3. A “Engine Fault Check Engine” message, and an “Emission Fault” message will appear on the monitor, the action lamp will flash, and an audible alarm will sound for 20 for seconds prior to the level 3 inducement. The engine will be taken to low idle or will be shut down. After the level 3 inducement you may cycle the key, which will allow 20 minutes of engine run time with full torque. After 20 minutes, the engine will be in level 3 final inducement and will allow idle only or be shut down until the issue has been resolved. Once shut down, the engine can be restarted for 5 minute periods at reduced speed and torque. If set to idle, the engine will idle indefinitely at reduced torque.

NOTE: Contact CZM after-sales support for repairs if a fault occurs.

Machine Security System*

SMCS Code: 7631

General Information*

i07426447

IMPORTANT

This machine may be equipped with a CAT® Machine Security System (MSS) and may not start under certain conditions.

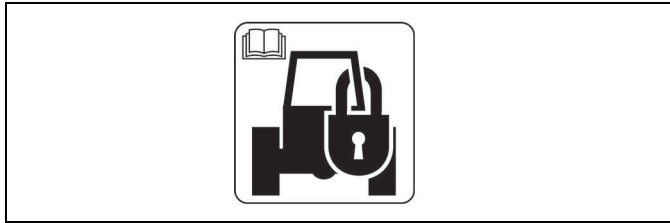

g06223917

Figure 7-37: CAT® MSS Decal

Machines that are equipped with CAT® MSS can be identified by a decal in the operator station. Read the following information and know your machine settings. Your CAT® dealer can identify your machine settings.

The CAT® Machine Security System (MSS) discourages unwanted operation of a machine. When armed, the MSS requires operator login to start the engine. The following methods of operator login to disarm the security system are available:

- CAT® Bluetooth® key fob
- CAT® myEquipment mobile application
- Passcode

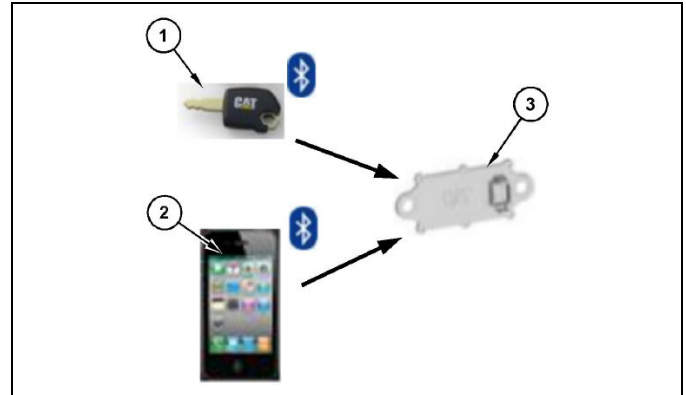

g06212167

Figure 7-38: Bluetooth Connections

1. CAT® Bluetooth key fob (CATBTFOB)
2. Smart phone application
3. CAT® Bluetooth transceiver (CATBTNT)

The CAT® Bluetooth key fob (1) contains an electronic chip. The electronic chip has a unique identification number (ID). A Bluetooth transceiver is mounted in the cab to read the ID of the key. The Bluetooth transceiver module translates the information received from the key fob into a J1939 message. This message is sent to the Electronic Control Module (ECM) that is connected to the MSS. The ECM is typically the Machine ECM. The ECM is set up with the ID of the keys of the intended users.

When the MSS is armed, the ECM validates the ID of the key fob. If the key ID is on the list of authorized keys in the ECM and the key is valid, the machine will operate normally. If the key ID is not on the list of authorized keys in the ECM or is not valid, the MSS will keep the critical machine functions disabled.

If the MSS is not installed, the operator can skip the login and the machine will operate normally.

Components*

The Machine Security System (MSS) consists of the following components:

- Electronic Control Module (ECM)
- CAT® Bluetooth key fob (CATBTFOB)
- Machine
- Display
- Bluetooth transceiver module (CATBTNT)
- Engine start switch

OPERATION

System Overview*

The Machine Security System (MSS) is designed to restrict operation of a machine. A list of the authorized electronic keys and passcodes for a machine is contained in the Engine Control Module (ECM) for the MSS. A valid Bluetooth key fob, mobile application, or passcode can disarm the MSS. If the MSS is disabled or not installed, any operator may access critical machine functions.

The CAT® Electronic Technician (CAT® ET) Service Tool can be used to program the ECM with the authorized keys and passcodes. Bluetooth devices and passcodes can be registered using the in-cab display if the operator is logged in to the system using a master access account.

When the engine start switch is turned to the ON position, the display boots up. If Bluetooth detection is enabled, the transceiver will receive a signal from any Bluetooth key that is present or from the mobile application. The ECM will then compare this ID to the list of authorized keys.

NOTE: If multiple devices are present, the first valid device detected by the transceiver will be read.

If the ID of the key matches an authorized key, the status indicator on the engine start switch will turn a green color and the MSS will disarm. This disarming will allow the operator access to critical functions of the machine.

If the ID of the key that is read does not match the list in the ECM, the status indicator will remain a red color. The MSS remains in the “armed” state and the machine will remain disabled.

If the MSS is disabled and the ID of the key matches an authorized key, the operator will be identified and allowed access to the critical machine functions. The operator will be able to save configurations and start the machine.

If the MSS is disabled and the ID of the key that is read does not match an authorized key, the operator must log in as a guest. The operator will not be able to save custom configurations but will have access to starting the engine.

Activating Bluetooth Functionality*

For shipping purposes, Bluetooth functionality is deactivated. Ensure that Bluetooth functionality is active on your machine using the following procedure:

1. Ensure that the function is active from the radio screen.

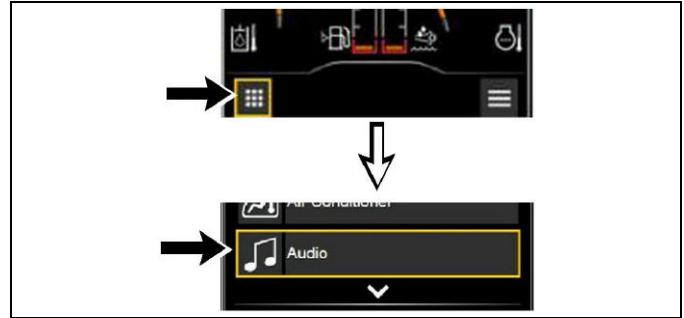

Figure 7-39

2. From the home screen, press the navigation button in the lower left corner, then select “Audio”.

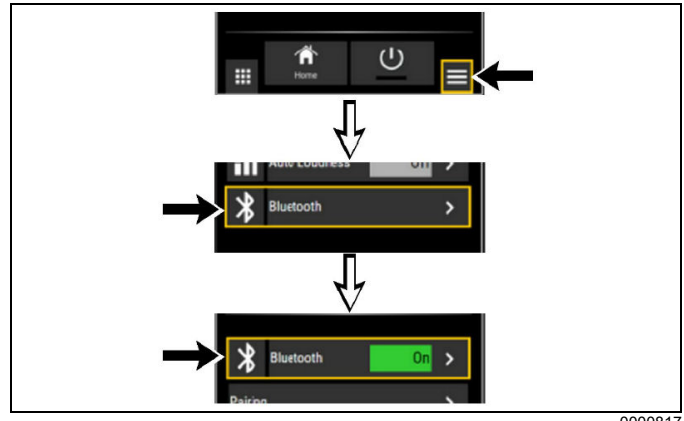

Figure 7-40

3. Press the radio function list menu button in the lower right corner, then select “Bluetooth”. Ensure that “Bluetooth” is set to “ON”.

Pairing Your Device to the Machine*

Use the following procedure to pair your device to the machine:

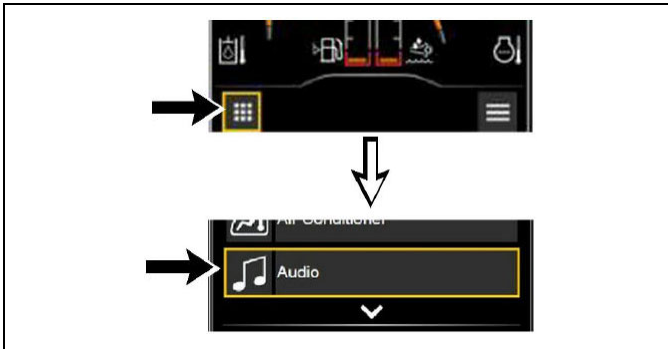

Figure 7-41

1. From the home screen, press the navigation button in the lower left corner, then select "Audio".

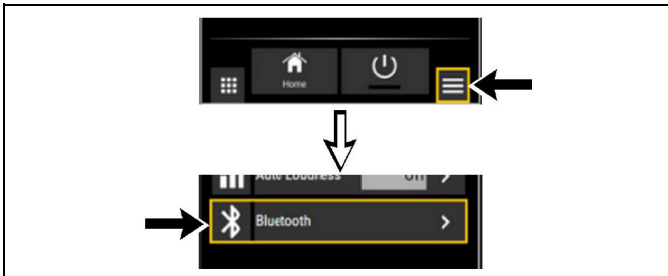

Figure 7-42

2. Press the radio function list menu button in the lower right corner, then select "Bluetooth".

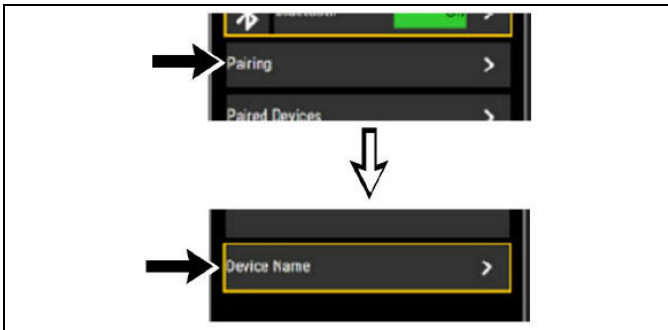

Figure 7-43

3. Select "Pairing", then "Device Name".

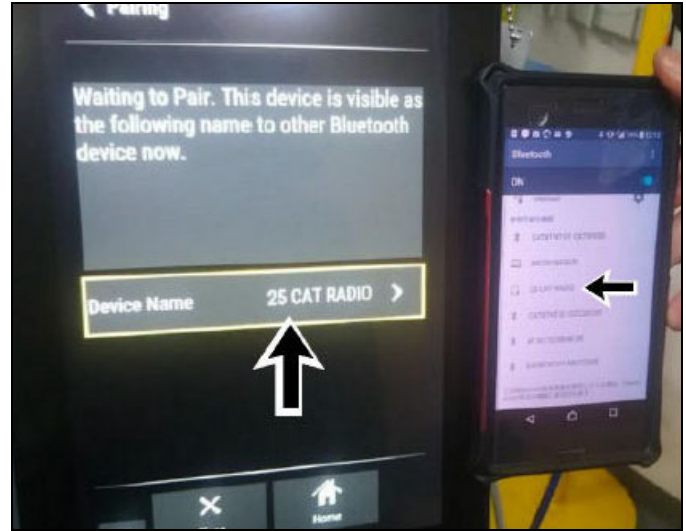

Figure 7-44: Device Name

Machine name on monitoring system and operator device.

Find your device on the list and pair the devices. Ensure that the devices are paired on your phone as well.

NOTE: The device name on your phone should be "## CAT® RADIO", with the number being from "00" to "99".

Reading the ID of a Key*

The Machine Security System (MSS) must identify a valid passcode, Bluetooth key fob ID, or CAT® myEquipment mobile application ID.

When the engine start switch ring is turned to the ON position, the MSS will check the ID of any key fob or mobile application. If the ID matches a key ID stored in the machine Engine Control Module (ECM), the critical ECM functions are enabled. An enable message is also sent via the CAT® data link or J1939 data link to the other ECMs on the machine. The machine will operate normally.

NOTE: If the machine ECM has failed or has been removed, the critical machine operations controlled by the other electronic control modules will not operate.

Armed*

When the MSS is armed, critical machine functions are disabled. The MSS disables the power that is supplied to each component that is powered by the output drivers. The machine will not be able to operate normally.

There are two states of operation within the "armed" mode:

OPERATION

1. **Engine Start Switch Ring Position OFF** – When no power is applied to the MSS, the MSS will default to “armed” state. When power is applied to the MSS and the grace period has expired, the MSS will return to the “MSS Armed”.
2. **Engine Start Ring Switch Position ON** – When the engine start switch ring is first moved to the ON position, the display boots up and the system attempts to detect a Bluetooth key ID or mobile application ID. The ECM will continue reading until a valid key ID is read or a passcode is entered. If a valid key ID or passcode is not read, the MSS status indicator will remain red and the MSS remains armed.

Disarmed*

When the MSS is disarmed, normal machine operation is allowed. A message is sent to the other machine ECMs over the CAT® data link. or J1939 data link. The machine will be able to start. The green LED on the status indicator will illuminate.

There are multiple ways to disarm the machine:

- Use a valid passcode.
- Use a valid Bluetooth key fob.
- Use the CAT® myEquipment mobile application.
- Use the CAT® Electronic Technician (CAT® ET) Service Tool to configure the MSS bypass schedule to allow machine operations during scheduled periods of time during the week.

Grace Period*

After a machine has been started successfully, the operator will have a grace period after the machine is turned off before the MSS is automatically armed.

The operator is not required to arm the system manually.

During the grace period an operator can start the machine without a key ID or passcode. When the grace period expires, the MSS will rearm automatically.

If the MSS is unable to read a key ID, the system will remain armed. When the MSS identifies a key with an invalid key ID, the system will remain armed.

The grace period for a machine can be configured with CAT® ET if a factory password or master level account is available.

Navigating the User Interface Touchscreen Display*

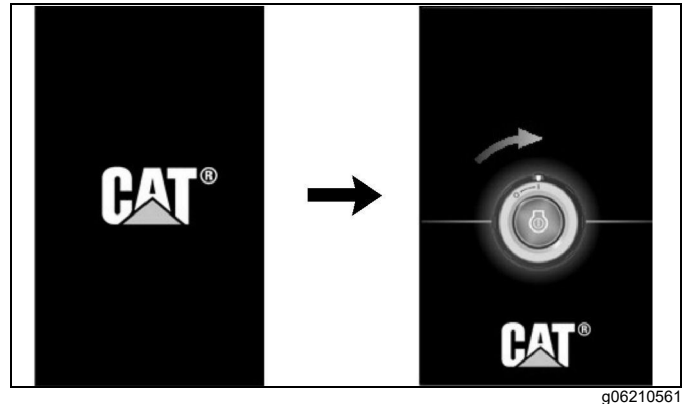

Figure 7-45: Startup Sequence Screens

The display will start up automatically after turning the battery disconnect switch to the ON position. The screen will prompt the operator to turn the engine start ring to the ON position. When the engine start ring is turned to the ON position, the display will navigate to the passcode entry screen.

If the operator has not turned the engine start ring to the ON position, the display will time out after 1 minute.

If the battery disconnect switch is already on and the display is off, the display will startup automatically after the engine start ring is powered on. The CAT® screen will appear for a short time and then login keypad will appear.

NOTE: Avoid touching the screen with sharp objects.

The access level assigned to the operator can limit or expand the amount of freedom the user has to manage the system. The following paragraphs explain access levels.

There are three levels of operator access recognized by the touchscreen display. The following levels are available:

- Guest
- Standard
- Master

Guest – If an operator does not have an authenticated key or passcode, the user is able to bypass log in as a guest. Some menu features will not be available such as the options for saving configurations and operator management. If the Machine Security System (MSS) is enabled, guest operators cannot start the machine.

Standard – A standard operator is a registered user of the machine. Operators with this access level can start the engine whether or not the MSS is installed. This user may save a control configuration for future application.

Master – Master accounts can perform operator management in addition to all standard level functions.

Any “Standard” or “Master” account may be created or removed by a “Master” level operator.

Selections and Access for the Touchscreen Display	
Access Level	Operator Setting
Guest	“Operator Input Configuration” “Response” “Change Operator”
Standard	“Operator Input Configuration” “Response” “Controls Setup” “Change Operator”
Master	“Operator Input Configuration” “Response” “Controls Setup” “Change Operator” “Manage Operator”

Operation of Status Indicator*

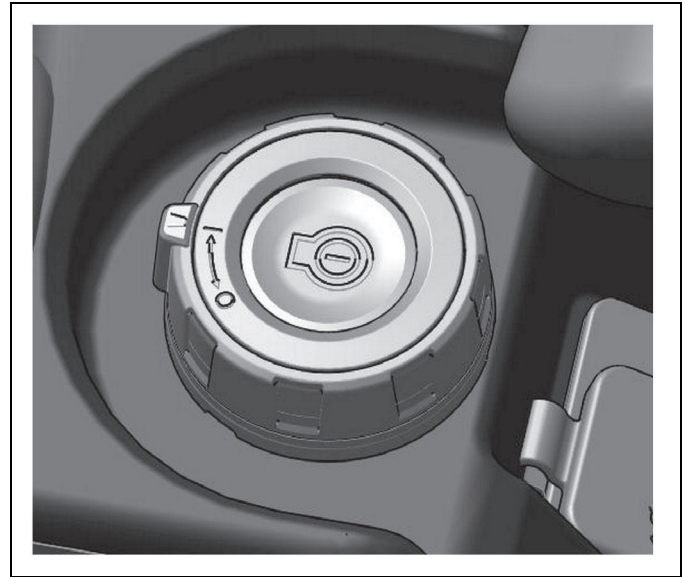

g06215426

Figure 7-46: Engine Start Switch with MSS Indicator

The Machine Security System (MSS) uses a status indicator that is integrated into the engine start switch in the cab. This indicator provides a visible alert for the security system.

The operator can use the status indicator to determine the status of the system or for troubleshooting.



g06226442

Figure 7-47: Status Indicator - MSS Armed

When the MSS is armed, the status indicator will be red. The red light warns the operator that the machine is armed with the security system and that an operator login is required. The red LED will remain ON until a valid key is read while the key switch or engine start switch ring is in the ON position.

OPERATION



g06226444

Figure 7-48: Status Indicator - MSS Disarmed or Uninstalled

When the MSS is disarmed, the status indicator will be green. The green light notifies the operator that an operator is logged on the machine and the security system has been disarmed. The status indicator will be green if the MSS is not installed on the machine.

Also, the green LED will remain ON after power down for the duration of the grace period. After the grace period, the MSS automatically returns to the “armed” mode.

For machines with a standard key switch, a separate status indicator will be available.

Operator Login*

Any user may start the engine if the Machine Security System (MSS) is disabled.

If the MSS is active, only a “Standard” or “Master” account can start the machine engine. Before starting the machine engine, the security system must identify a registered operator. An operator can access the machine display using one of the following methods:

- Passcode
- CAT® Bluetooth key
- CAT® myEquipment mobile application

Passcode Entry*

To log in using a passcode, refer to the following steps:

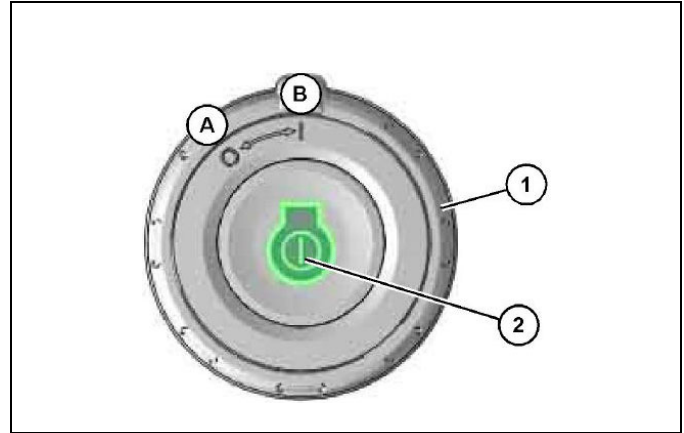

g06180554

Figure 7-49: Engine Start Switch

(A) Off

(B) On

(1) Engine start switch ring

(2) Engine start button

1. Turn engine start switch (1) to the ON position (B).



g06209470

Figure 7-50

2. Enter a registered passcode using the monitor keypad and then press “Enter”.

NOTE: The jog dial or the numbered buttons on the right-side switch panel can also be used to enter the code.



Figure 7-51

g06211194

3. Select “Enter” to confirm the passcode. If a registered passcode is recognized, the operator information screen will appear on the display. If the MSS is not installed, the passcode screen will be bypassed automatically after 10 seconds. The operator will be logged in to the system as a guest. Refer to Figure 7-51.
4. Select “OK” to continue to the display home screen.

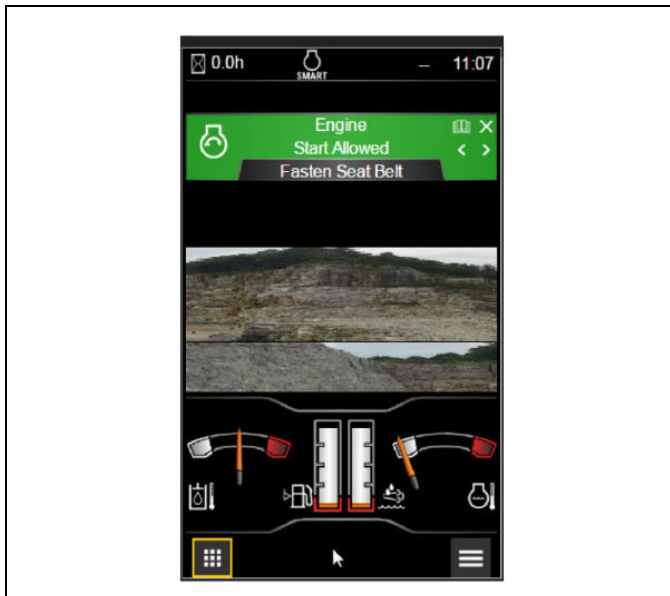

Figure 7-52

g06209482

5. After an operator logs in to the system successfully, an “Engine Start Allowed” message will appear across the top of the monitor. Refer to Operation and Maintenance Manual, Engine Starting for instructions on starting the engine.

Invalid Passcode*



Figure 7-53

g06209472

If a passcode is not recognized, the display will notify the user with an “Invalid code” message. Refer to Figure 7-53.

The operator has five tries to enter a valid passcode successfully. After a fifth unsuccessful attempt, a lockout screen will appear and remain on the display for a duration of 5 minutes.

NOTE: If the Machine Security System (MSS) is not active, the user can select the “Skip Login” button to avoid the lockout period. Refer to the “Bypass login” section for further information.

Bypass login*

Operator login can be bypassed if the user selects the “Skip Login” button on the display. The operator will be logged in to the machine with “Guest” level access.

If the MSS is inactive, the operator will be able to start the engine as normal and view all display screens.

If the MSS is active on the machine, the operator is able to view all display screens but will not have access to starting the engine.

OPERATION

Bluetooth Entry*

Alternatively, a Bluetooth Operator ID can be used to log in to the machine. For a Bluetooth key to be detected by the system, ensure that the following qualifications are met:

- The key must be registered with the machine.
- The key must be within the cab.
- Bluetooth setting must be enabled on the display.

Refer to the following steps when logging in to a machine using the Bluetooth key:

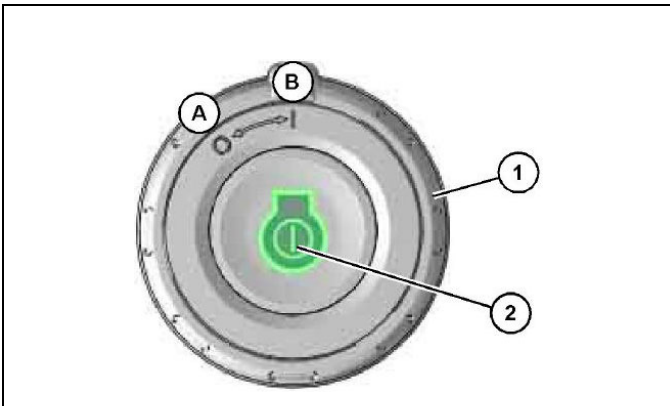

Figure 7-54: Engine Start Switch

- (A) Off
- (B) On
- (1) Engine start switch ring
- (2) Engine start button

1. Turn engine start switch (1) to the ON position (B).
2. Wait several seconds for the system to detect the key when the passcode dialog appears. Once the key is detected, the “Operator Information” screen will display.

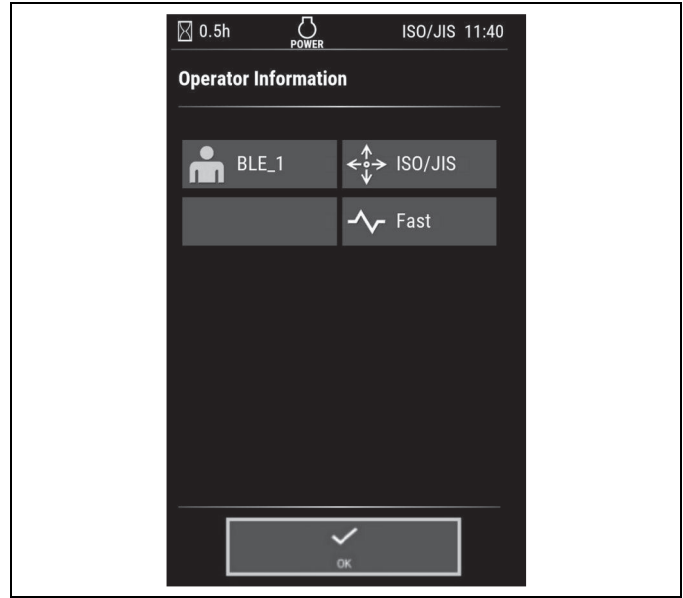

Figure 7-55

3. Select the “OK” button if the proper operator has been displayed.

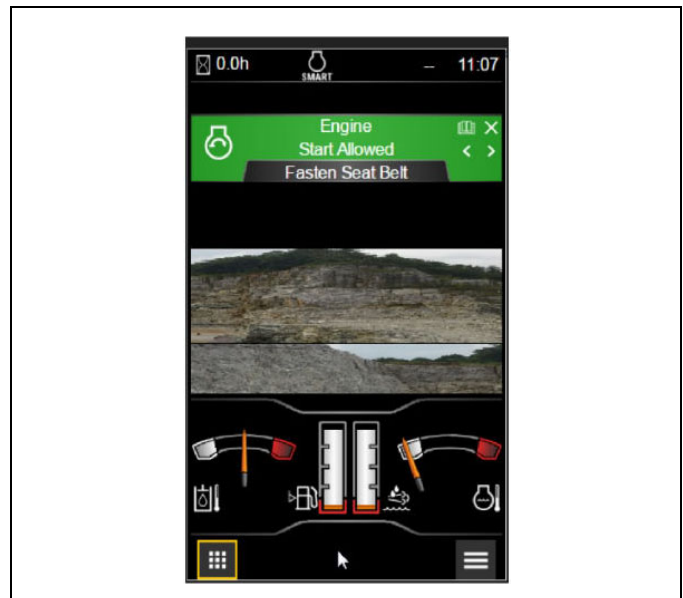

Figure 7-56

4. After an operator logs in to the system successfully, an “Engine Start Allowed” message will appear across the top of the monitor. Refer to the Operation and Maintenance Manual, “Engine Starting” for instructions on starting the engine.

IMPORTANT

The access level will change to a “Guest” account automatically if the key is removed from the cab at any time. If the MSS is enabled and the engine is on when the key is removed from the cab, the operator will not be able to start the engine if turned off. To turn on the engine again without the Bluetooth key, the operator will need to log in a registered account using either the smart phone application or passcode.

NOTE: If multiple Bluetooth devices are within the cab, the system will select the first device detected by the Bluetooth transceiver as the active operator.

CAT® Fleet Management Mobile Application*

Operators can also log in to a machine using the CAT® App: Fleet management mobile application. For the application to be detected by the system, ensure that the following qualifications are met:

- The Mobile Device ID (MDID) of the mobile application must be assigned to the machine in the Operator Management System (OMS).
- The mobile device must be within the cab.
- “Operator Management Bluetooth Device Enabled Status” is enabled (Cat ET Configuration) Mobile Application Entry (Android Devices)*.

NOTES:

- *It is not possible to assign mobile devices through the Machine Security System (MSS) interface.*
- *For adding an operator, adding MDID to the machine key list, and pushing the machine key list from the OMS to the machine refer to the OMS documentation at: <https://myoperators.cat.com/>*

Mobile Device/Operating Software Compatibility

Make	Model	Operating Software
Android	Varies	Android 8.x Oreo and up (Preferably Android 9.x Pie)
Apple	iPhone 6/ iPhone 6 Plus and up	iOS 11.0 and up (Preferably 12)

NOTE: *Android mobile hardware support for Bluetooth can vary, so it is possible that a mobile device running Android 8.x software or higher could have hardware that does not support Bluetooth 4.1.*

OPERATION

Mobile Application Entry (Android Devices)*

To log in using the CAT® App: Fleet management mobile application, refer to the following steps:

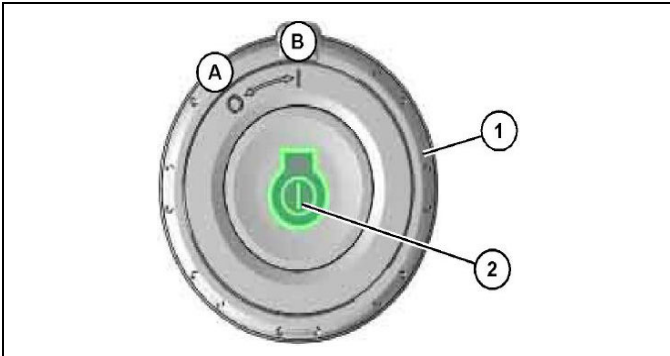

g06180554

Figure 7-57: Engine Start Switch

- (A) Off
- (B) On
- (1) Engine start switch ring
- (2) Engine start button

1. Turn the engine start switch (1) to the ON position (B).
2. Open the CAT® App: Fleet management application on the mobile device.



0000797

Figure 7-58

3. Click "I Agree" to agree with the End-User License Agreement and sign in with CAT® eCustomer account credentials.

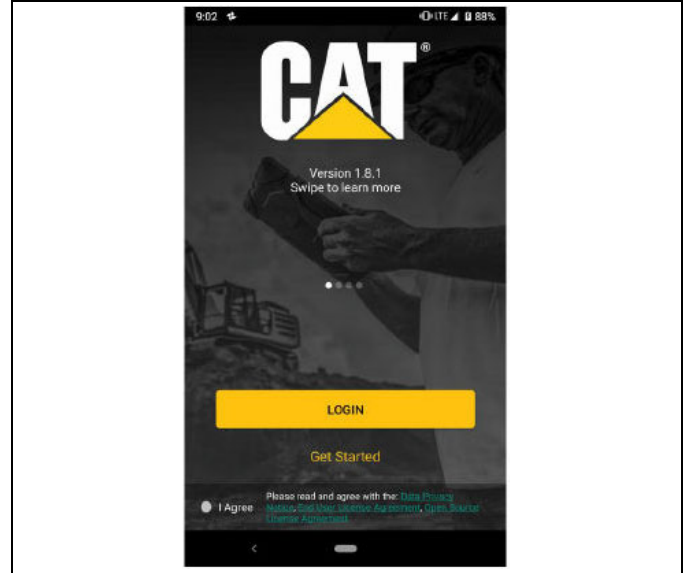

0000798

Figure 7-59

NOTE: If you do not have a CAT® eCustomer account, click "Get Started" to create one.

4. Select "Login".
5. Enter CAT® eCustomer account credentials.

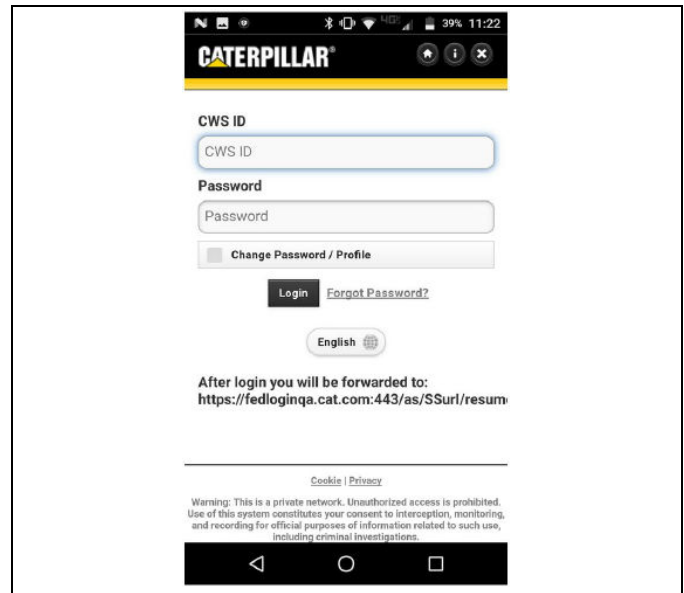

0000799

Figure 7-60

6. Click "Allow" to enable the CAT®App: Fleet management mobile application to work as designed.

NOTE: CAT® App: Fleet management requires access to the mobile device location to use Bluetooth radio to connect to CAT® machines.

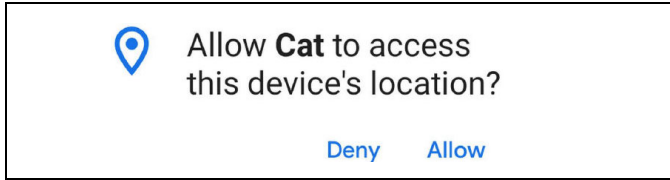

Figure 7-61

0000800

- Upon login, the CAT® App: Fleet management mobile application will open onto the equipment tab.

NOTE: The “Equipment” tab will be empty on the first login.

The Menu Icon (1) includes “Preferences”, “Notifications and Alerts”, along with various documents covering the end-user license agreement, and privacy notice.

By tapping the Map Icon (2), the operator will be able to see the location of each vehicle on their “Equipment” tab on a map.

If a vehicle is not equipped with a telematics device, or the vehicle is a non-caterpillar machine it may be necessary to add it manually using the Add Equipment Icon (3).

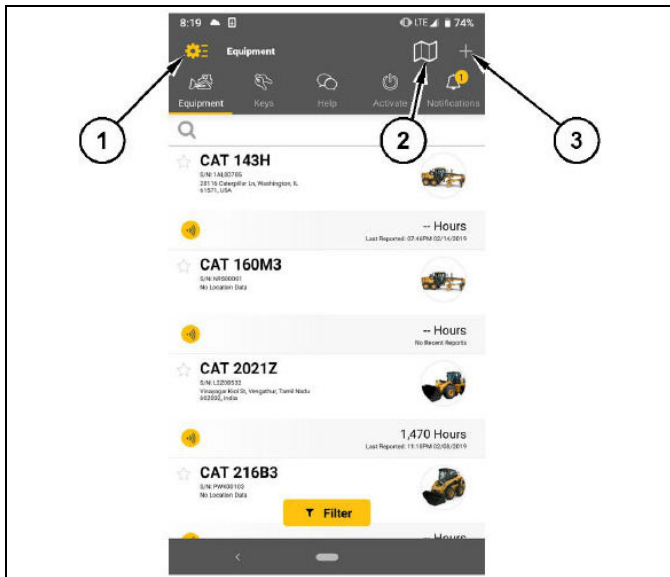

Figure 7-62

0000801

- Go to the keys tab. Keys are necessary to connect to vehicles. If no keys are given, the screen shown below will be displayed. The MDID is necessary to assign keys to the user account. The MDID of Android devices is linked to the app.

NOTE: Uninstalling the CAT® App: Fleet management mobile application will result in the MDID and keys being deleted. The Sim card of the phone contains the MDID information, damage to the Sim card

may result in keys being lost, if the phone is replaced transfer the Sim card to avoid key loss.

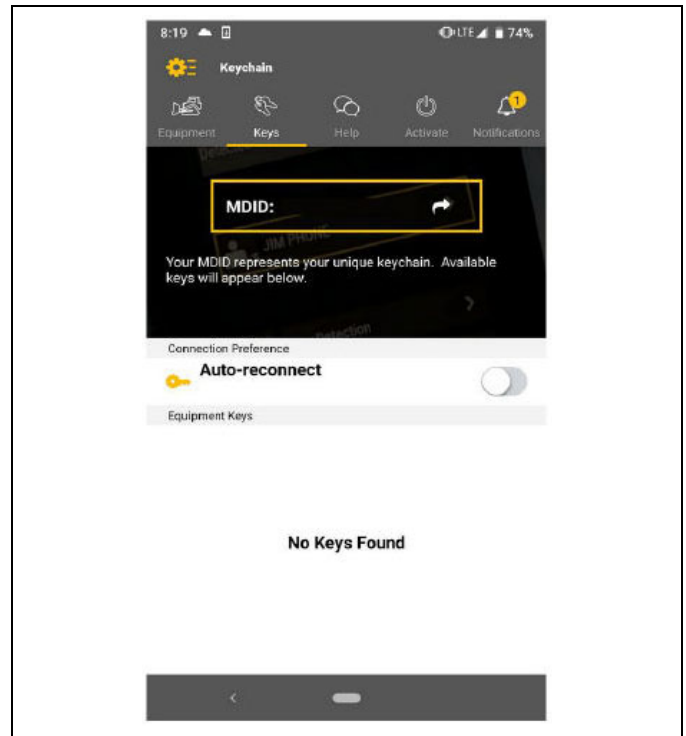

Figure 7-63

0000802

- Pull the “Equipment Keys” down to refresh the list once the Fleet/Key configuration process has finished. Wait up to 30 seconds until the keys populate. If the keys do not populate, check that the MDID is correct and that the list was pushed properly through OMS.
- Ensure that the machine is ON to connect to a machine. The machine display should prompt the operator for a password. In the “Keys” tab in the CAT® App: Fleet management mobile application and tap the key that matches the machine. If a vehicle is OFF, currently occupied, or too far away the key will be grayed out and say “Out of range”.

NOTE: If the machine has a user signed in that is not in the cab and it has become necessary for a different user to operate the machine, change the operator in the operator setting.

OPERATION

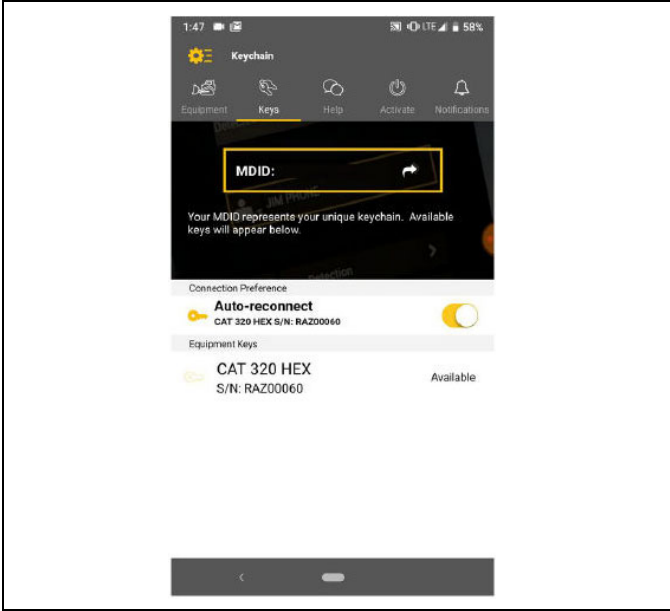

Figure 7-64

0000803

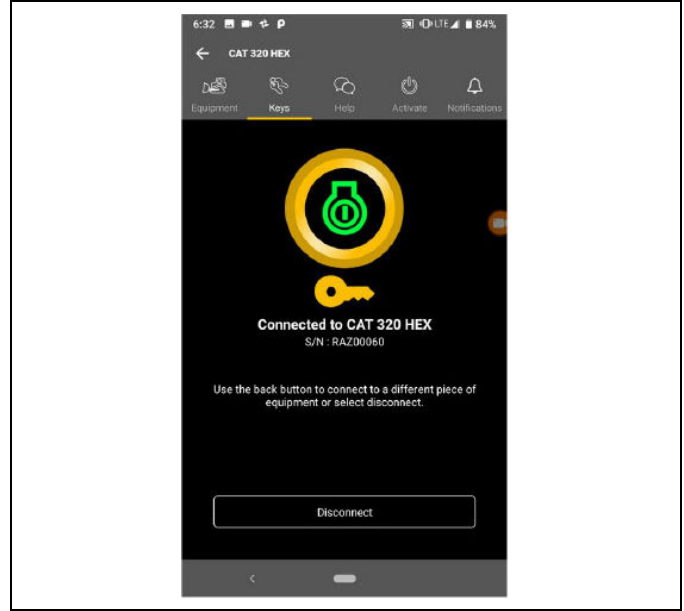

Figure 7-66

0000805

11. Access the “Equipment” tab by tapping it. The machines associated with the keys should have populated. To learn more about a machine, tap it.

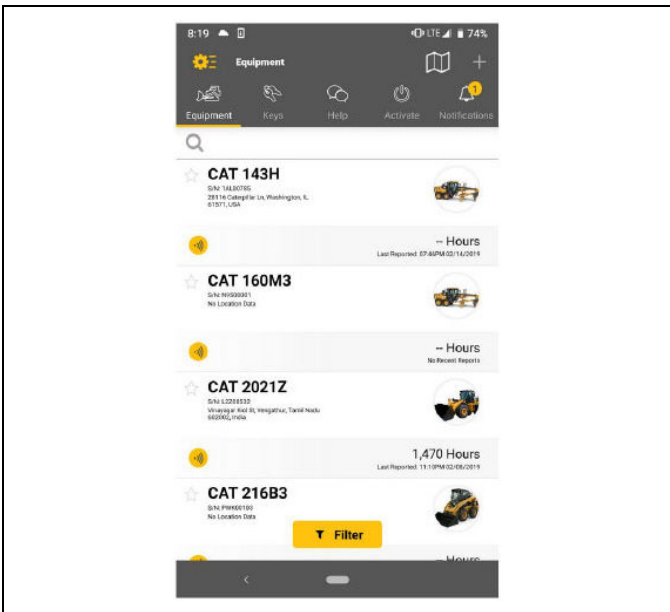

Figure 7-65

0000804

13. After an operator logs in to the system successfully, an “Engine Start Allowed” message will appear across the top of the monitor. Refer to “Engine Starting*” on page 7-32 for instructions on starting the engine.

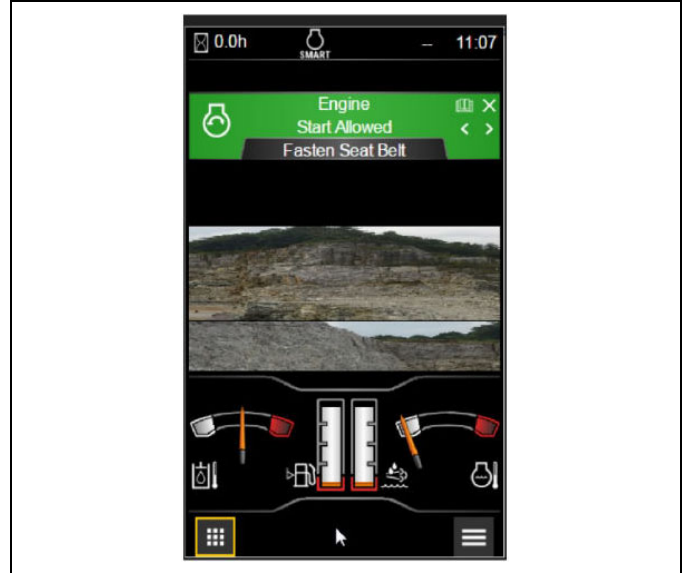

Figure 7-67

0000806

12. Press the “Disconnect” button if the user wishes to disconnect. If the user wants to switch machines, tap the arrow in the upper left then tap the machine the operator wants to be switched to.

NOTE: Disconnect from vehicles if the user is not going to be using a vehicle again within a short time.

Mobile Application Entry (iOS Devices)*

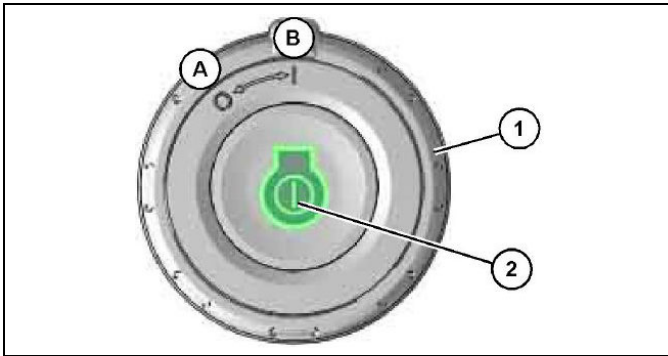

g06180554

Figure 7-68: Engine Start Switch

- (A) Off
- (B) On
- (1) Engine start switch ring
- (2) Engine start button

1. Turn engine start switch (1) to the ON position (B).
2. Ensure that Bluetooth detection is enabled on the in-cab display.
3. Open the CAT® App: Fleet management mobile application on the mobile device.



0000807

Figure 7-69

4. Click "I Agree" to agree with the End-User License Agreement and sign in with CAT® eCustomer account credentials.

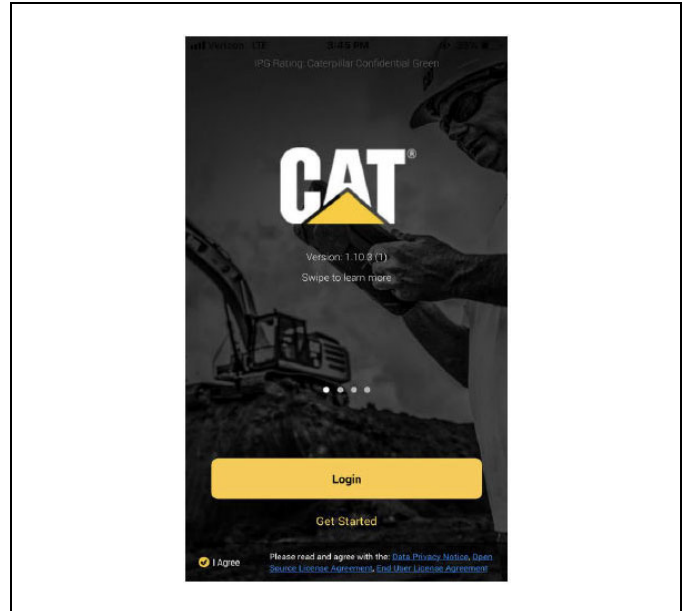

0000808

Figure 7-70

NOTE: If you do not have a CAT® eCustomer account, click "Get Started" to create one.

5. Select "Login".
6. Enter CAT® eCustomer account credentials.

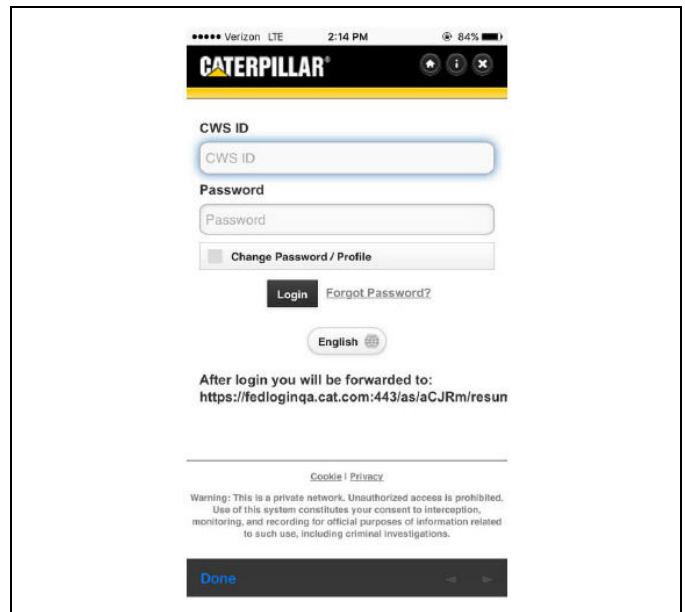

0000809

Figure 7-71

7. Upon login, the CAT® App: Fleet management mobile application will open onto the equipment tab.

NOTE: The "Equipment" tab will be empty on the first login.

OPERATION

The Menu Icon (1) includes “Preferences”, “Notifications and Alerts”, along with various documents covering the end-user license agreement, and privacy notice.

By tapping the Map Icon (2), the operator will be able to see the location of each vehicle on their “Equipment” tab on a map.

If a vehicle is not equipped with a telematics device, or the vehicle is a non-caterpillar machine it may be necessary to add it manually using the “Add Equipment” icon (3).

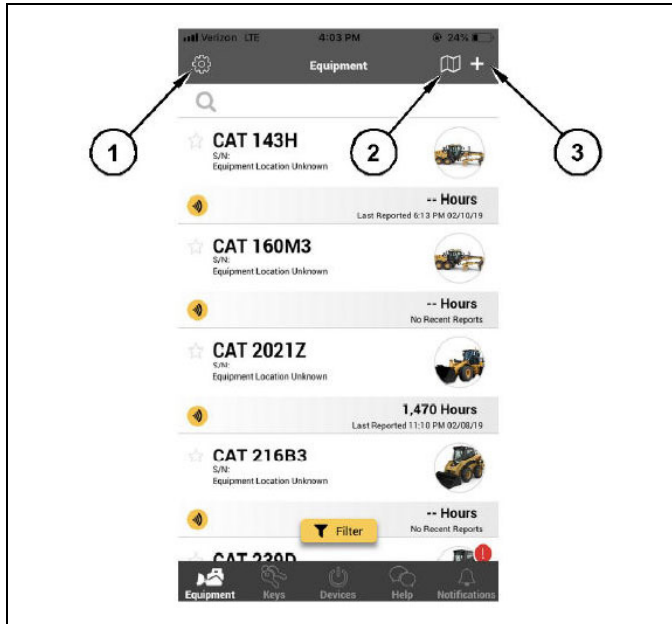
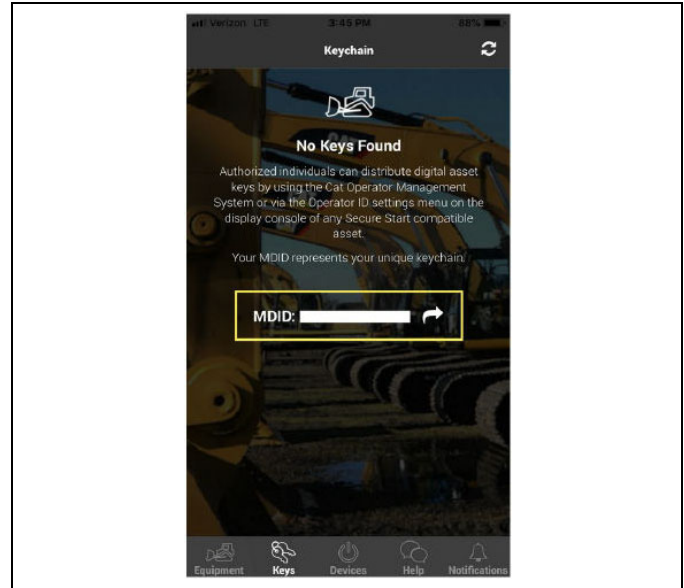

Figure 7-72

0000810

8. Go to the keys tab. Keys are necessary to connect to vehicles. If no keys are given, the screen shown below will be displayed. The MDID is necessary to assign keys to the user account. The MDID of iOS devices is linked to the user account.



0000811

Figure 7-73

9. Once the Fleet/Key configuration process has finished, tap the refresh button in the CAT® App: Fleet management mobile application top right. Wait up to 30 seconds until the keys populate. If the keys do not populate, check that the MDID is correct and that the list was pushed properly in OMS.
10. To connect to a machine, ensure that the machine is ON. The machine display should prompt the operator for a password. At this point on the CAT® App: Fleet management mobile application go to the “Keys” tab and tap the key that matches the machine. If a vehicle is OFF, currently occupied, or too far away the key will be grayed out and say “Out of range”.

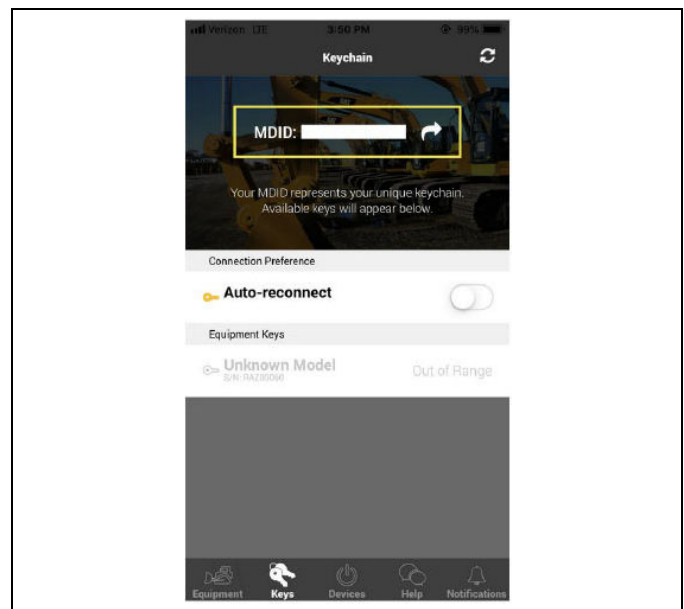

0000812

Figure 7-74

- Press the “Disconnect” button if the user wishes to disconnect. If the user wants to switch machines, tap the arrow in the upper left then tap the machine the operator wants to be switched to.

NOTE: Disconnect from vehicles if the user is not going to be using a vehicle again within a short time.

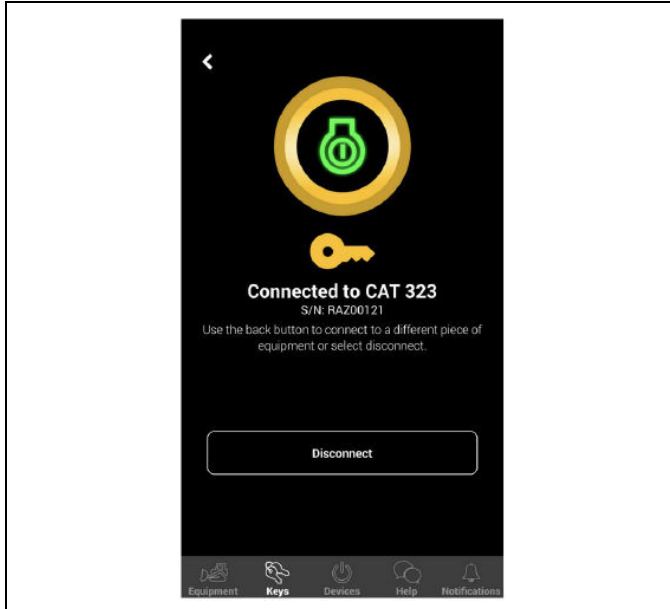

0000813

Figure 7-75

- After an operator logs in to the system successfully, an “Engine Start Allowed” message will appear across the top of the monitor. Refer to “Engine Starting*” on page 7-32 for instructions on starting the engine.

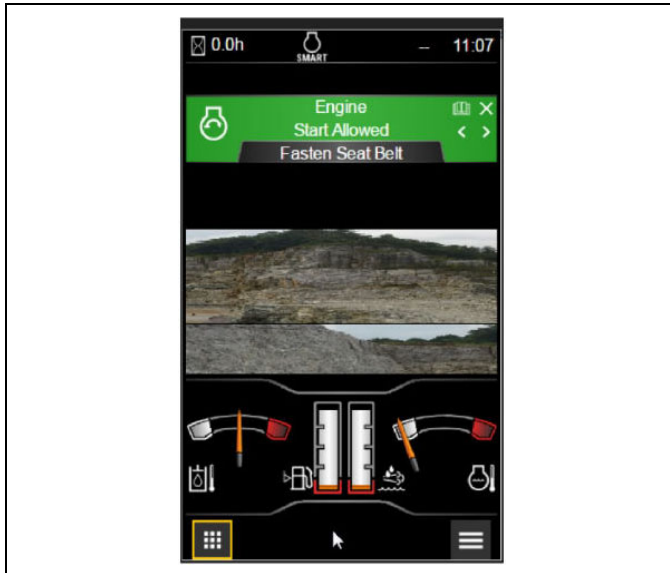

0000814

Figure 7-76

OPERATION

Engine Starting*

SMCS Code: 1000; 1090; 1456; 7000

NOTICE

This machine is equipped with a Machine Security System (MSS) and may not start under certain conditions. Contact the CZM After Sales Department for additional information.

NOTICE

The engine start switch must be in the ON position and the engine must be running in order to maintain electrical functions and hydraulic functions. This procedure must be followed in order to prevent serious machine damage.

NOTE: The engine can start in areas that have temperatures as low as -18°C (0°F). For areas that are colder, a starting kit for cold weather is available.

1. Move the hydraulic lockout control to the LOCKED position.
This machine is equipped with an engine neutral start system. The system only allows the engine to start when the lever for the hydraulic lockout control is in the LOCKED position.
2. Ensure the joysticks and travel controls are in the HOLD position.
3. The operator passcode, Bluetooth key or myEquipment app must be authenticated before starting the engine. Once authenticated, an “Engine Start Allowed” message will appear across the top of the monitor and the start switch LED will turn green.

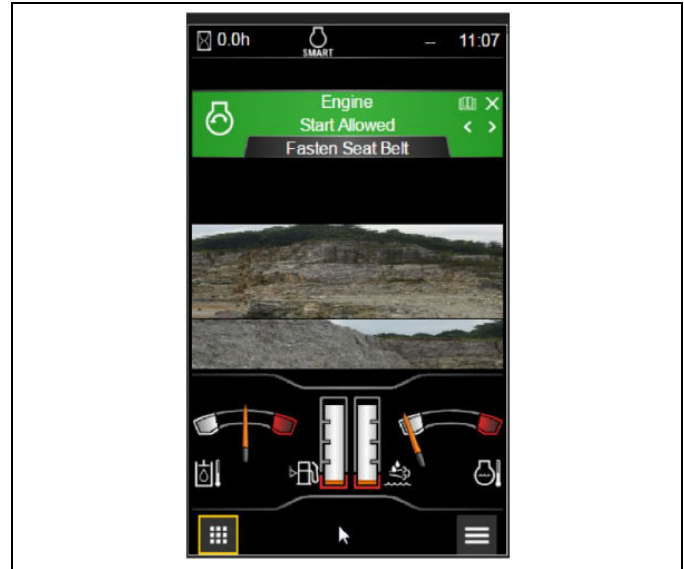

g06209482

Figure 7-77

4. Bluetooth devices and passcodes can be registered using the in-cab display if the operator is logged in to the system using a master access account. Contact your CAT® dealer for additional information. Refer to “Operator Login*” on page 7-22 for instructions.

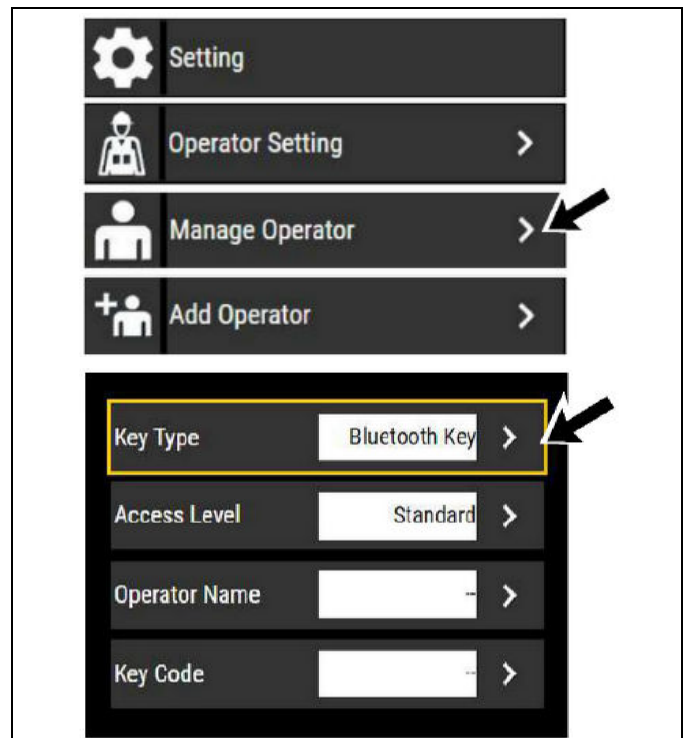

0000815

Figure 7-78

5. Before you start the engine, check for the presence of bystanders or maintenance personnel. Ensure that all personnel are clear of the machine. Briefly sound the horn before you start the engine.

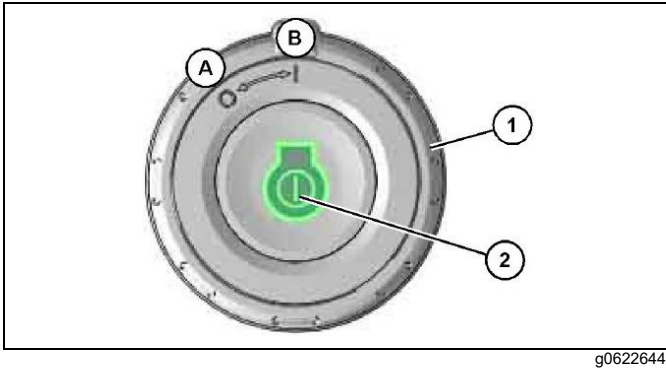

Figure 7-79: Engine Start Switch

- | | | |
|----------------------|---|-----|
| 1) Engine start ring | A | Off |
| 2) Start button | B | On |
6. Turn the engine start ring (1) to the ON position, then press and hold the start button (2) to start the engine. Release the button after the engine has started.

NOTE: If the engine is having trouble starting, do not crank the engine for more than 30 seconds. Cranking the engine for more than 30 seconds can damage starting system components.

OPERATION

Engine Start Switch Troubleshooting*

Table 28

Switch Status	Possible Cause	Resolution
Engine start switch is not illuminated	Engine start accessory power not on	Turn engine start switch ring to ON position
Engine start switch is green		Cycle engine start switch ring and try to restart
Engine start switch is red		Contact your CAT® dealer
		Hydraulic lock in LOCKED position
		Cycle engine start switch ring and try restart
		Add operator to machine authorized user list
		Switch operator from guest mode using display
		Add operator to machine authorized user list
		Replace key fob battery
		Ensure more than 4.5 m (15 ft) from other Bluetooth equipped machine
		Alternately login with display passcode or contact local CAT® dealer
		Add operator to machine authorized user list
		Ensure more than 4.5 m (15 ft) from other Bluetooth equipped machine
		Enable phone Bluetooth and connect myEquipment app
		Change Bluetooth system enable status to enabled (CAT® dealer)
		Contact local CAT® dealer if unable to see machine Bluetooth device

Engine and Machine Warm-Up*

SMCS Code: 1000: 7000

NOTICE

Keep engine speed low and do not operate until the message "Warm-Up Mode Power Derate" on the monitor goes out. If it does not go out within thirty seconds, stop the engine and investigate the cause before starting again. Failure to do so, can cause engine damage.

NOTICE

Always run the engine at low idle for at least ten minutes before performing any other operations in cold conditions or each time the engine oil and oil filter are changed in order to protect your engine and hydraulic components.

NOTICE

Depending on the ambient temperature, in order to prevent the machine operation with high speed without sufficient lubrication at the turbo bearing, the engine speed may be set to low speed and the hydraulic power minimized for a pre-determined time after the engine starts. Refer to turbo protection feature.

The engine may automatically change speeds when the machine is stationary and idling in cold ambient temperature for an extended time. This is to:

- Maintain desired coolant temperature.
- Maintain desired operation of engine systems.

During extended idling in cold ambient conditions, engine speed may operate between 900 rpm and 1000 rpm. Operation at 1000 rpm is minimal and will only last for up to 20 minutes.

Hydraulic System

Automatic Warm-Up*

This machine comes with an automatic warm-up feature that can be enabled or disabled. If the feature is enabled, and the hydraulic oil temperature is below the threshold that has been set, a prompt will appear on the monitor after starting the machine. Follow the prompts on the monitor. If this feature is disabled or you would like to change the temperature setting, from the main screen, press the application menu button. In the Application menu:

1. Select "Setting".
2. Select "Machine Setting".
3. Select "Auto Warm Up".

To enable or disable auto warm-up, press the "Auto Warm Up Enable Status" window, then select "Enabled" or "Disabled".

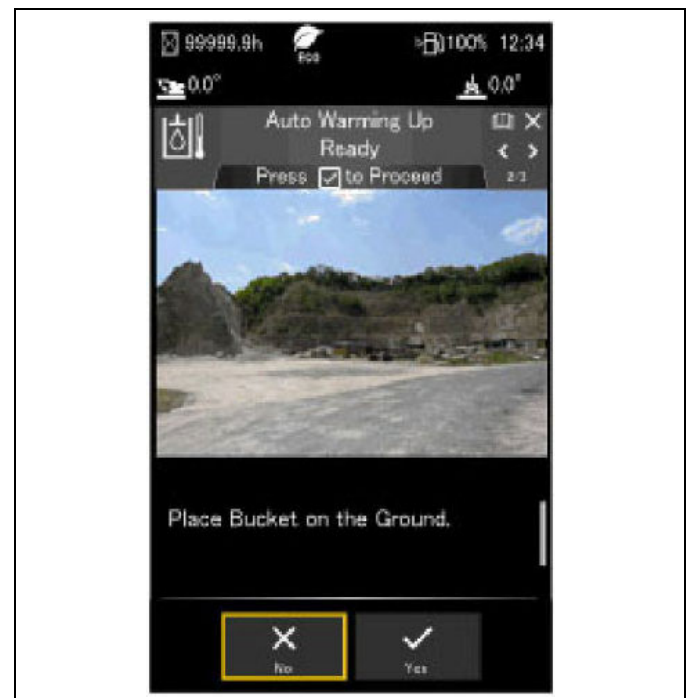

g06219830

Figure 7-80: Auto Warm-Temperature

OPERATION

Manual Warm-Up*

WARNING

When you cycle the machine controls, the machine can move suddenly. Contact between the machine and external objects or ground personnel can result in serious injury or death. Before you cycle the machine controls, the machine should be located in an unobstructed, hazard-free work area that is away from external objects and ground personnel.

1. Make sure that the area is clear of personnel and equipment.

NOTE: The hydraulic lockout control must be in the UNLOCKED position before the hydraulic controls will function.

2. Allow the engine to warm up at low idle for at least 5 minutes. Engage the work tool controls and disengage the work tool controls. This will speed up the warm-up of the hydraulic components.

When you idle the machine for warm-up, observe the following recommendations:

- If the temperature is greater than 0°C (32°F), warm up the engine for approximately 15 minutes.
- If the temperature is less than 0°C (32°F), warm up the engine for approximately 30 minutes.
- If the temperature is less than -18°C (0°F) or if hydraulic functions are sluggish, additional time may be required.

NOTICE

The hydraulic oil temperature should be higher than 25°C (77°F) before performing work with the machine. Make sure that the warm-up procedure is performed.

If the hydraulic oil temperature is less than 25 ° C (77 ° F) and the machine is operated abruptly, serious damage to the hydraulic components may occur.

NOTE: The recommended operating temperature of the hydraulic fluid for this machine is 55°C (131°F).

3. To warm up the hydraulic oil, turn the engine speed dial to the medium engine speed. Run the engine for approximately 5 minutes and move the joystick intermittently from the crowd up position to the crowd down position. Do not hold the joystick in the crowd up or down position for more than 10 seconds after reaching maximum/minimum crowd cylinder positions.

This allows the oil to attain relief pressure, which causes the oil to warm up more rapidly.

4. Turn the engine speed dial to the maximum engine speed and repeat Step 3.
5. Cycle all controls to circulate warm oil through all hydraulic cylinders and all hydraulic lines, and through the swing motor and travel motors.
6. Observe the gauges and the indicators frequently during the operation.



Turbo Protection Power Derate – After an engine start, the engine speed will be set to low speed and the hydraulic power limited for a time period. During this period, the monitor displays the message "Warm-Up Mode Power Derate" (Maximum is around 30 seconds). After the turbo bearing lubrication is sufficient, the engine speed goes to the set dial speed and the monitor stops displaying the power derate message.

Improve Cold-Weather Performance*

Covers installed over the vents in the radiator compartment door will help to control overcooling in ambient temperatures below -15°C (5°F).

The materials used for the covers and the method used to install the covers is at the installers discretion.

Install the covers if overcooling is observed while the machine is idling in ambient temperatures below -15°C (5°F).

Stop the machine, and remove the covers under the following conditions:

- The ambient temperature is above -15°C (5° F).
- The engine temperature gauge indicates overheating.
- The hydraulic oil temperature gauge indicates overheating.

Recommendation for Crankcase Breather Protection (Machines with C4.4 and C7.1)*

Crankcase ventilation gases contain a large quantity of water vapor. This water vapor can freeze in cold ambient conditions and can plug or damage the crankcase ventilation system. If the engine is operated in temperatures below -25°C (-13°F), measures must be taken to prevent freezing and plugging of the breather system. Insulated hoses and a heated canister assembly should be installed.

Consult with your CZM after-sales support for the recommended breather components for operation from -25° to -40°C (-13° to -40°F).

Installation*



g06181368

Figure 7-81: Radiator Compartment Door

Vent locations on the radiator compartment door.

1. Clean the surface of the radiator compartment door.
2. Install the covers in the locations shown. The covers should fully cover the door vents.

NOTE: There should be movement in the auxiliary hydraulic lines as the pressure is released. If there is no movement in the auxiliary hydraulic lines, start the engine and run the engine for 20 seconds. Repeat steps 1 to 5.

OPERATION

Machine Setup for Drilling

⚠️ WARNING

Any person assisting the operator in this phase must:

- Keep fingers and other body parts away from pinch points to prevent crushing injuries while operating the drilling rig.
- Never place body parts under drilling-rig components while operating the drilling rig.
- Remain within the operator's field of vision when the machine is being moved or operated.
- Understand how to communicate with the operator using standard hand signals.

Failure to follow this warning could result in death or serious injury.

Prepare the machine for drilling after transporting it to the work site. Some procedures must be done with the drilling rig in motion, with the operator on board, and with help of an assistant, who must perform steps directly on the machine.

⚠️ WARNING

Perform these steps in the described order. You risk a tip over. Failure to follow this warning could result in death or serious injury.

The main steps for drilling setup are:

1. Extending the undercarriage.
2. Positioning the machine at the site using forward/reverse travel and turning.
3. Positioning the mast in the work position.
4. Connecting the work tool.

For setup procedures, see **Chapter 8, "Machine Setup for Drilling"**.

Forward and Reverse Travel

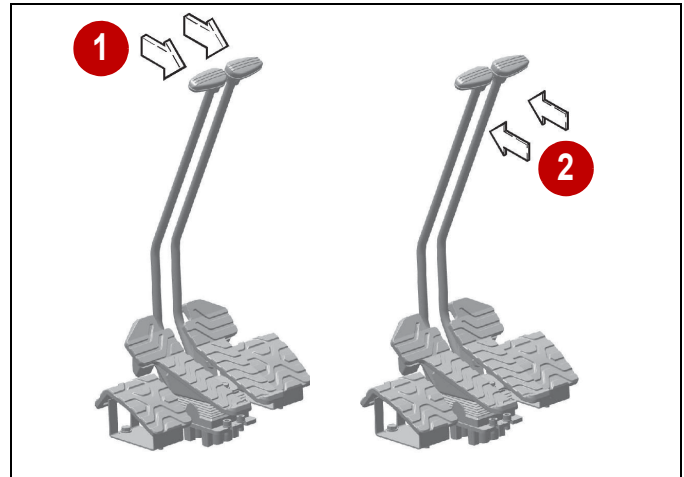

0000322

Figure 7-82

- 1) Reverse Travel
- 2) Forward Travel

Move both of the travel levers or travel pedals equally in the same direction to travel backward and forward.

Push forward on the travel control pedals or levers for forward travel.

Pull back on the travel control pedals or levers for reverse travel.

To stop, release the travel levers/pedals. The travel controls will return to neutral position, stop the machine, and apply the travel brakes.

Turning

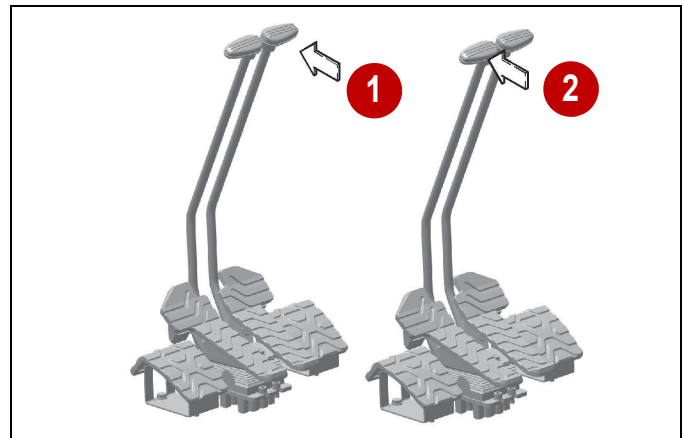

0000323

Figure 7-83

- 1) Forward Left Turn
- 2) Forward Right Turn

Move either the left and right travel lever or pedal in a forward direction relative to the other travel lever or pedal to move the machine forward to the left or right. For reverse turns, move the travel lever or pedal in the reverse direction.

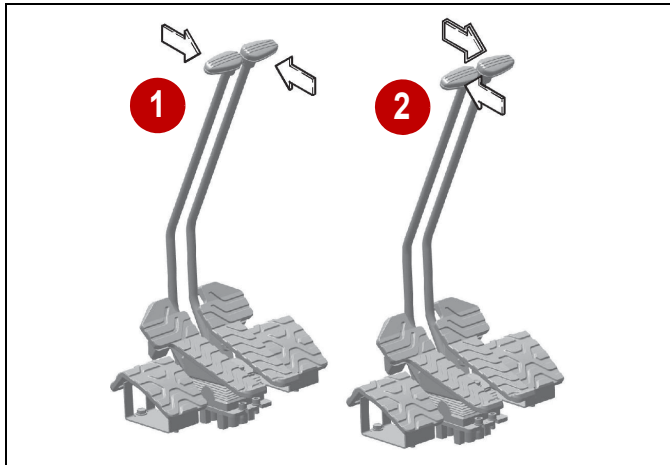

0000324

Figure 7-84

- | | |
|--------------------------------|---------------------------------|
| 1) Counter-Rotate Left
Turn | 2) Counter-Rotate Right
Turn |
|--------------------------------|---------------------------------|

Make tight radius turns by placing the travel lever on one side in a forward direction and the opposite travel lever or pedal in a reverse direction.

When you make turns in soft material, travel in a forward direction occasionally to clear the tracks.

Slopes

If possible travel up and down slopes with the final drive sprockets facing down the slope.

Special precautions must be taken when moving the machine on slopes:

- Do not travel slopes with a gradient of more than 15 degrees.
- Do not travel across slopes.
- Avoid changing the direction of travel on a slope.

OPERATION

Drilling Operations

Standard Drilling

CAUTION

Do not move the tracks or swing the mast while the kelly bar is inside the hole. Movement of the mast or machine can cause severe damage to the machine.

NOTICE

When raising the kelly bar, the auger may inadvertently turn clockwise and lock up the kelly bar. This often happens when the drilling auger is under water or in collapsed soil. If this happens, slowly turn the auger counterclockwise while raising it. If the kelly bar remains locked, lower the auger back into the hole and unlock it. Trying to unlock the kelly bar while it is being raised could cause the locked element to fall resulting in damage to the kelly bar upper flange, break the main winch cable, or damage the crowd cylinder.

1. After transport and positioning the machine in the drilling area, setup the machine for drilling as described in Chapter 8 “Setup the Machine for Drilling”.
2. Position the machine so the auger is over the drilling location on stable, level ground.

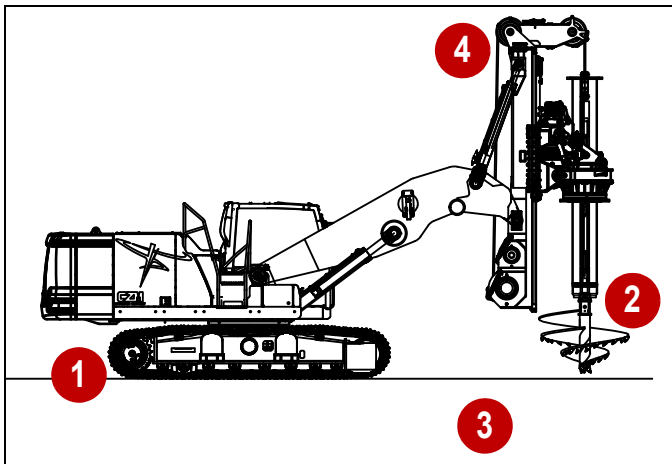
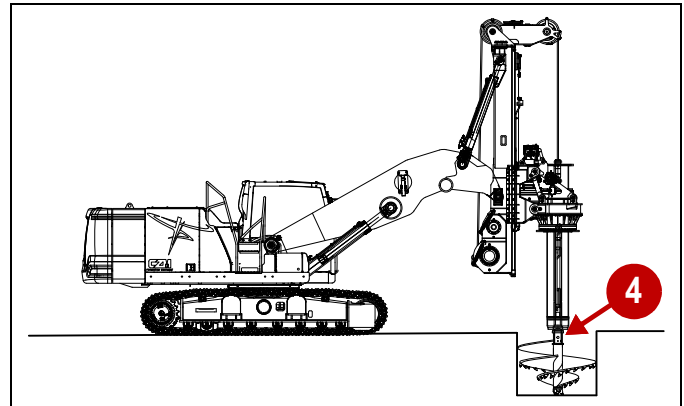

Figure 7-85

0000435

3. Check the machine status:
 - The undercarriage should be facing forward, with the travel motors at the rear (1).
 - Make sure the auger is correctly pinned to the kelly bar (2).
 - Make sure the safety perimeter around the machine is clear and secured (3).

4. Level the mast (4) using the mast auto level function, or using the tilt cylinder joystick controls.
5. Bring the center of the drilling tool to the center of the hole at ground level.
6. Set the drilling depth and machine swing to zero.
7. Set the engine speed to the maximum RPM for best performance.
8. Place the rotary in first gear.
9. To start drilling, move the right joystick to the right. This will start the rotary turning clockwise.
10. Simultaneously add crowd force by pushing the right joystick forward.



0000880

Figure 7-86

11. Start the hole slowly, making sure the auger is kept plumb. The top part of a hole is critical in drilling a hole straight down.
12. After drilling the length of the auger (4), stop drilling.
NOTE: Do not over-drill, drilling beyond the top of the auger may cause the auger to become stuck in the ground, requiring the operator to back-drill.
13. Most machines have an interlocking kelly bar. To unlock the kelly bar:
 - a. Raise the rotary.
 - b. Pull back on the right joystick to release the crowd pressure.
 - c. Slowly move the right joystick to the left to rotate the rotary counterclockwise. Continue until the kelly bars are unlocked. The deeper you are drilling, the more kelly bar elements are being used which will require more counter-clockwise rotation.

NOTE: Typically 1/2 turn per kelly bar element is required to unlock them. If you rotate the kelly bar too much, the auger will return drilling spoils back into the ground.

14. After the kelly bars are unlocked, raise the kelly bar with the main winch by pulling back on the left joystick.
15. Simultaneously raise the rotary by also pulling back on the right joystick.
16. You can also use the power shift to be on high-speed spin off. Depending on setup, the powershift can be set to momentary, latching, or auto mode. See "Third Screen" on page 6-23.

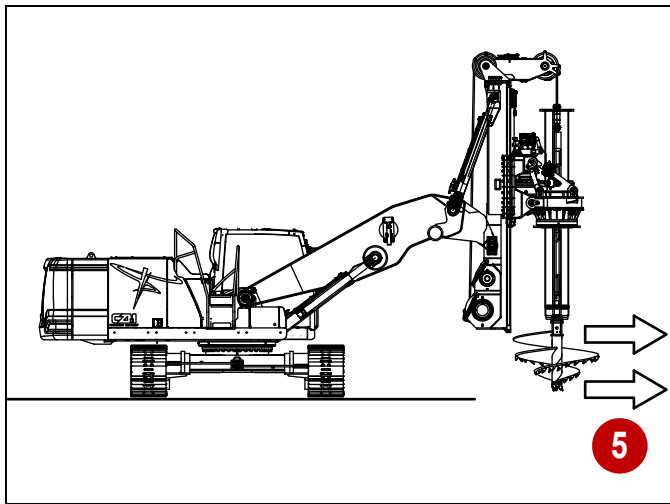

Figure 7-87

0000455

17. After the auger is above ground level, swing the mast (5) to the right or left by moving the left joystick to the left or right.
18. Spin-off the soil spoils from the auger.
19. Return the auger to the center of the hole manually or use the auto-return push button on the left joystick.
20. Push the left joystick forward to lower the kelly bar inside the hole using the main winch.
21. While lowering the kelly bar, slow down before the upper flange contacts the rotary to prevent damage to the kelly bar. Also slow down the rate of lowering when transitioning between kelly bar elements.

NOTE: The machine will automatically stop the main winch when the auger reaches the bottom of the hole. See "Bottom-Hole System" on page 7-45.

22. If there is some slack in the main winch cable, raise the winch cable up slightly to put some tension on the cable before starting to drill.

CAUTION

Remove the slack on the cable before drilling. Failure to do so will damage the cable and could cause the tool and kelly bar to fall into the hole.

23. To lock the kelly bar, find the position of the locks and start turning the rotary clockwise and then applying crowd force.

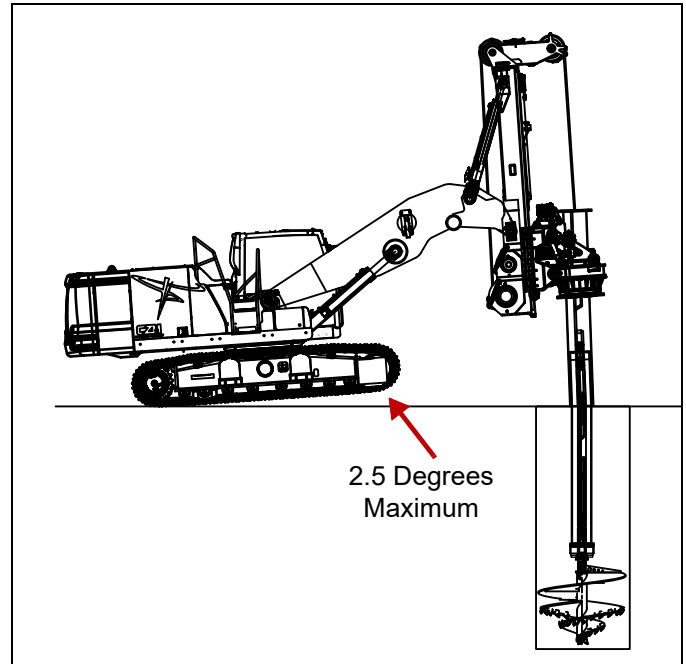

Figure 7-88

0000437

CAUTION

Do not overcrowd the kelly bar. Overcrowding is when the machine is lifted of the ground more than 2.5 degrees. Overcrowding will cause the kelly bar to flex inside the hole and may result in it breaking from repeated fatigue stress.

Some drilling rig models are equipped with an overcrowd alert or automatic protection that will alert or prevent an operator from overcrowding.

OPERATION

Automatic Drilling Functions

Auto Drill (Drill Lock)

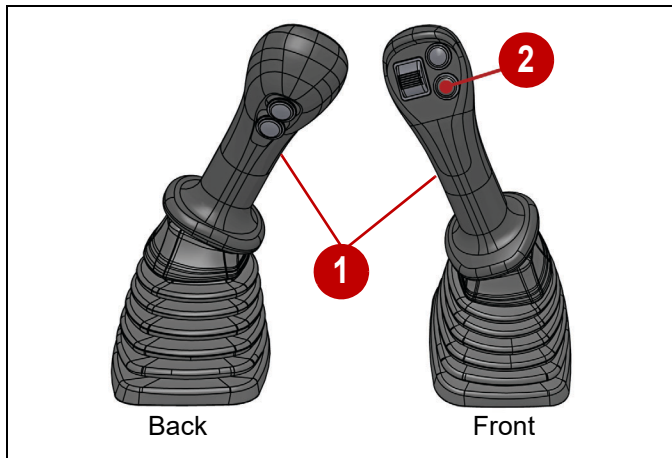

Figure 7-89: Auto Drill Button

- 1) Right Joystick
- 2) Auto Drill Button

Use the auto drill feature so that the operator does not have to hold the right joystick to the right to turn the rotary clockwise.

To turn on the auto drill, press the auto drill pushbutton (2) on the right joystick. As a safety feature, turning on the auto drill is only available if the auger is inside the hole and the machine auger is centered to the hole. Make sure that the depth and swing angle sensor are zeroed out in this position to be able to use the auto drill function.

Any movement on the rotary joystick or pushing the auto drill push button again deactivates the auto drill function. The operator can still change the rotary gears, from 1 to 3 and adjust the rotary rpm without disengaging the auto drill.

Auto Crowd

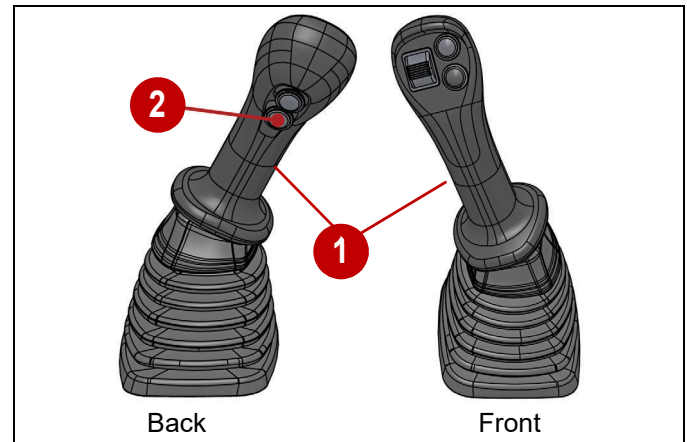

Figure 7-90: Auto Crowd Button

- 1) Right Joystick
- 2) Auto Crowd Button

The auto crowd function applies a constant crowd pressure while drilling. The drill lock needs to be engaged before the auto crowd can be turned on. The machine monitors the rotary torque and how much the machine is being lifted off the ground and adjusts the crowd pressure to avoid overcrowding and stalling of the rotary. The operator can change the maximum crowd speed.

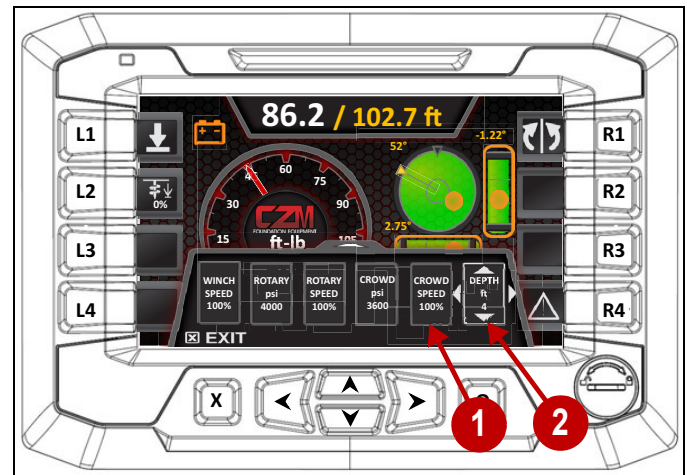

Figure 7-91

NOTE: Adjust the crowd speed (1) on the second monitor screen. See "Second Screen" on page 6-19.

Any movement to the crowd joystick or pressing the auto crowd push button deactivates the auto crowd function. After the length of the auger is reached, the auto crowd function will turn off. The operator can set the auger length.

NOTE: Set the auger length on the second monitor screen using the depth setting (2). See "Second Screen" on page 6-19.

Auto Mast Level

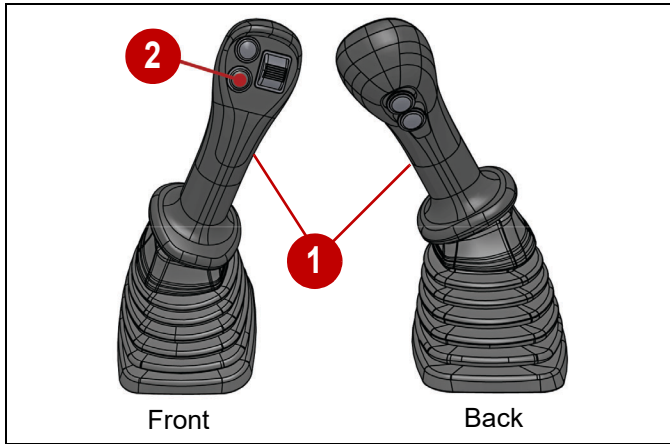

0000824

Figure 7-92: Mast Auto Level Button

- 1) Left Joystick
- 2) Auto Level Button

The operator can auto level the mast by holding the auto level button on the left joystick. The mast needs to be within 10 degrees of plumb for the auto level function to operate. Releasing the button stops the mast movement.

Return to Center

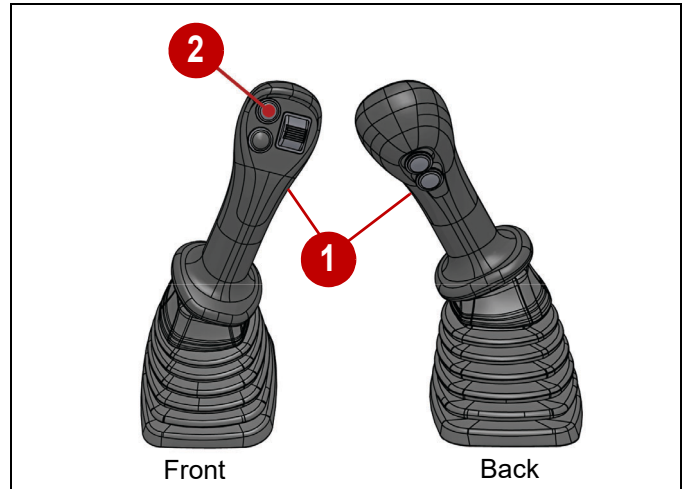

0000825

Figure 7-93: Return to Center Button

- 1) Left Joystick
- 2) Return To Center Button

Use the return to center push button to return the center of the auger to a pre-set center of the hole. Zero the swing position sensor at the center of the hole. The angle that the auger is off center is displayed on the monitor. Releasing the button stops the swing movement.

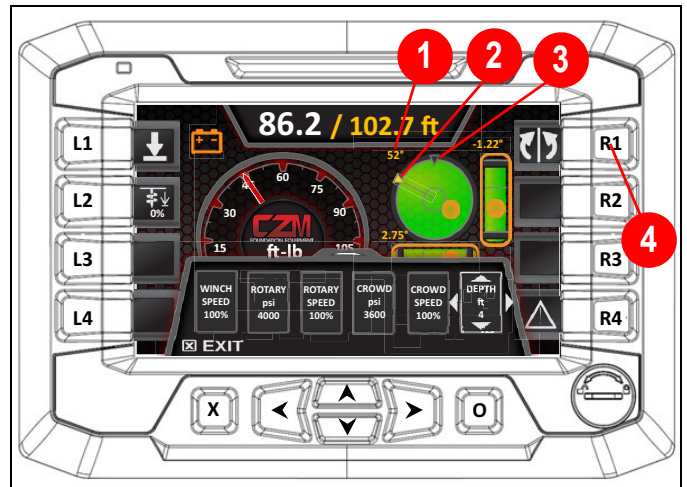

0000343

Figure 7-94: Swing Angle Display

- 1) Swing Angle Display
- 2) Swing Angle Graphic
- 3) Graphic Zero Point
- 4) Return to Center Switch

The machine swing angle is displayed on the home, first, and second monitor screens. To set the current swing angle to zero, press and hold the return to center switch (4).

OPERATION

Rotary Autoshift

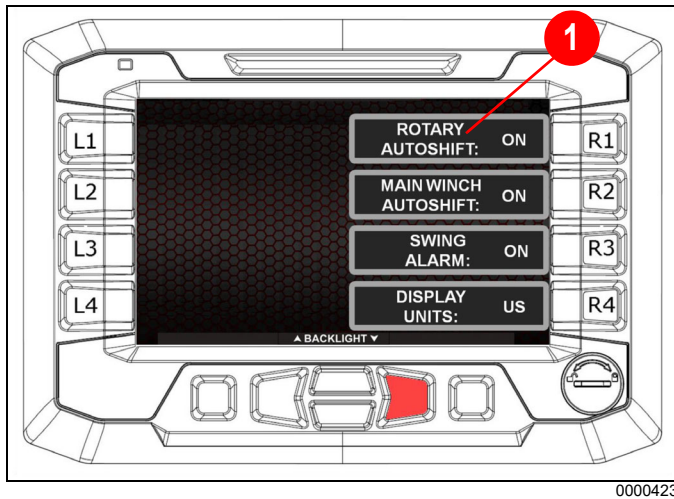

Figure 7-95 Rotary Autoshift

- 1) Rotary Autoshift

NOTE: Set the rotary auto gear shifting (1) on the third monitor screen. See “Third Screen” on page 6-23.

The operator can select to use auto gear shifting. See “Third Screen” on page 6-23.

If Auto is selected, the machine will monitor the pressure of the rotary, if it reaches a setpoint, the machine will downshift the rotary gear, to avoid stalling the rotary. If the pressure goes under another setpoint, the machine will upshift the rotary gear to increase the drilling speed. The machine will only upshift the gear back to the selected gear by the operator.

Main Winch Autoshift

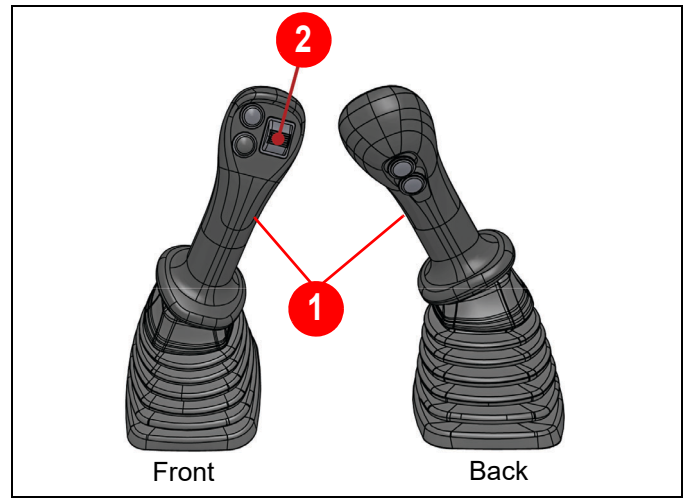

Figure 7-96: Main Winch Autoshift

- 1) Left Joystick
- 2) Main Winch Autoshift Pushbutton

The operator can select to use automatic gear shifting on the main winch.

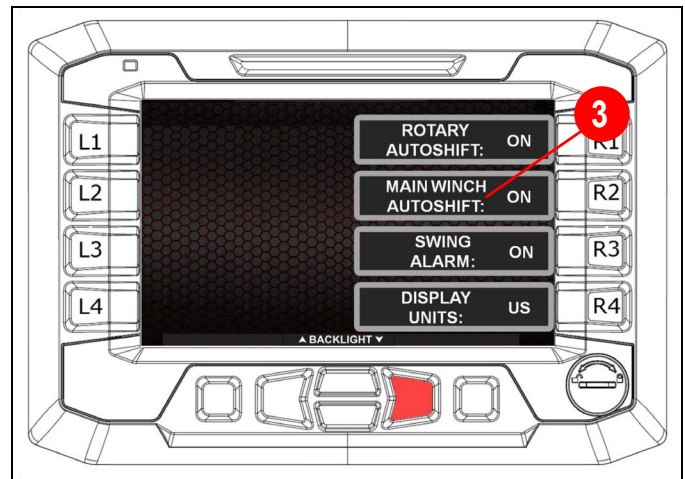

Figure 7-97 Main Winch Autoshift

- 3) Main Winch Autoshift

Set the main winch autoshift (3) on the third monitor screen. See “Third Screen” on page 6-23.

When autoshift is enabled for the main winch, the machine monitors the pressure of the main winch. When the pressure exceeds the high setpoint, the machine downshifts the main winch gear to provide more torque. If the pressure goes under the low setpoint, the machine upshifts the main winch gear to increase the line speed.

Auto Power-Shift (Spin-Off)

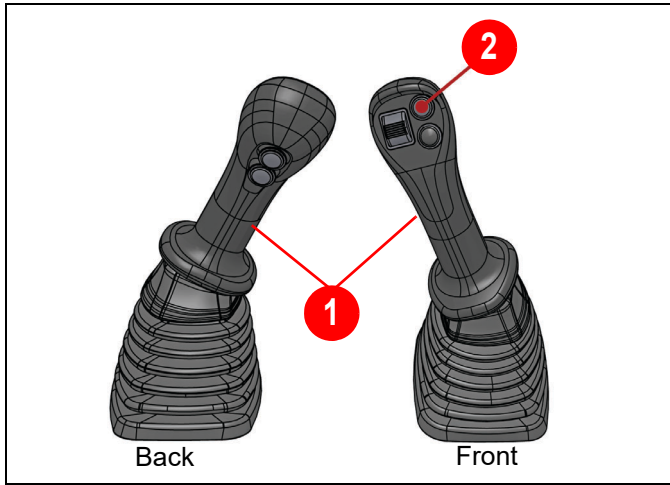

Figure 7-98: Power-Shift Pushbutton

- 1) Right Joystick
- 2) Power-Shift Button

The power-shift (spin-off) button can be set to operate as:

- Momentary
- Latching
- Automatic

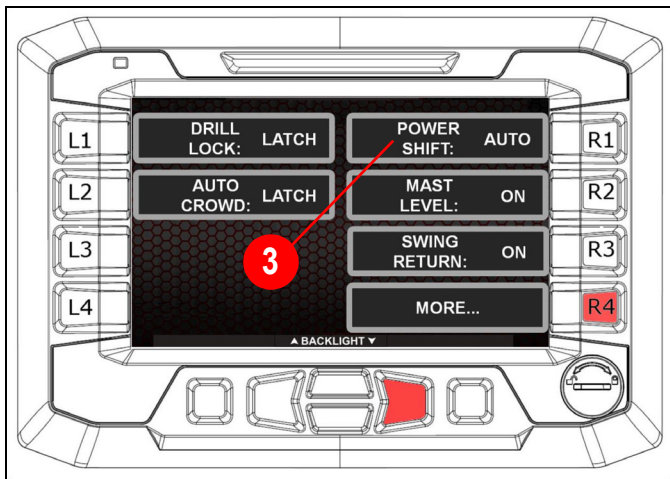

Figure 7-99 Power Shift

- 3) Power-Shift Setting

Set the power shift (3) on the third monitor screen. See “Third Screen” on page 6-23.

If momentary operation is selected, hold the push button to keep the spin-off on.

If latching operation is selected, press the push button to turn spin-off on and push it again to turn off the spin-off.

When auto spin-off is on, make sure to zero the depth and zero the swing angle sensors when the auger is positioned at the top of the hole.

The machine automatically turns on the spin-off, after the auger is above ground level and the base machine swings past a set angle from the zero position.

Spin-off turns off automatically after the auger returns to the center of the hole and the auger is placed inside the hole.

Spin-off can be manually turned on and off by pressing the spin-off button.

Overcrowd Protection System

The machine is equipped with an overcrowd protection system. This feature prevents the operator from lifting the machine off the ground beyond a set angle by slowing down the crowd speed according to a preset rotary torque. Adjust the preset rotary torque on the main monitor screen.

Bottom-Hole System

The bottom-hole system automatically stops the lowering of the kelly bar to prevent the main winch from unwinding too much wire rope from its drum.

NOTE: For some maintenance and machine setup, you will need to disable the bottom hole system. This allows operation of the main winch when there is no tension on the wire rope.

OPERATION

Drilling On Rock (Boulders)

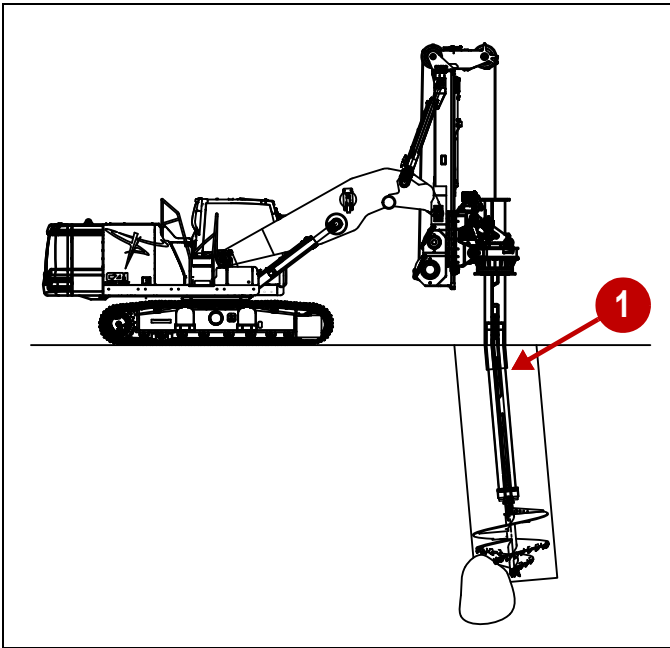

Figure 7-100

0000436

When drilling on boulders or solid rock, an auger can start to push to the side, going off-center. This may flex the kelly bar (1) and cause it to break with repeated fatigue stress.

In some situations, the machine operator should change the drilling tool to a core barrel tool to keep the hole plumb and avoid failure of the kelly bar.

Drilling on rock can take time and cause a lot of wear to the machine. Make sure you have the correct tool, either a rock auger or a core barrel with the correct teeth.

Change the teeth before they wear out or if they break, inspecting them constantly. Run the machine at very low rpm, to avoid wearing down the auger teeth too quickly.

The machines are equipped with a rock drill mode, which can be changed on the base machine monitor.

Rock drill mode supplies the rotary with hydraulic fluid from just one main pump, this reduces the speed of the rotary by 50%, without affecting the torque.

The operator may decide to reduce the speed even further, to as low as 3-4 rpm by adjusting the rotary speed on the CZM monitor.



Figure 7-101

0000343

NOTE: Adjust the rotary speed (1) on the second monitor screen. See “Second Screen” on page 6-19.

For smoother drilling operation, the operator can use the rotary drill lock and the auto crowd when drilling on rock.

Drilling on Slurry/Polymer or Bentonite

While drilling with a slurry, polymer, or bentonite, it may be beneficial to reduce the main winch speed, so that the slurry does not get too agitated. A slower winch speed will also reduce washing of the auger while it is going up, removing all the drilled soil spoils.



Figure 7-102

0000343

NOTE: Adjust the winch speed (1) on the second monitor screen. See “Second Screen” on page 6-19.

Installing a Casing

⚠️ WARNING

Handling casing with a drilling rig is a dangerous operation with many hazards:

- Make sure that the casing does not exceed the stability parameters of the drilling rig.
- Make sure the casing is well secured to the rotary, kelly bar or auxiliary winch while lifting it off the ground.
- Do not leave segments of casing standing up on the jobsite. Casing segments on the ground must be secured to prevent rolling.

Failure to follow proper safety precautions could result in death or serious injury.

When drilling under the water table or on unstable soil, a method of stabilizing the ground conditions might be required. Some methods to stabilize the ground conditions for drilling include:

- Using a stabilizing fluid such as polymer or bentonite.
- Using a casing.

There are two types of casings, J-lock and segmented.

Installing J-Lock Casing

1. Drill with an auger slightly larger in diameter than the casing down the depth of where the soil starts to become unstable.

⚠️ WARNING

Before using the service winch to lift casing, make sure the operation is within the safety limits of the machine. See Chapter 3, “Stability”.

2. Using a crane or the auxiliary winch, install the casing inside the open hole.
3. Remove the auger and install a cross bar in the bottom of the kelly bar.

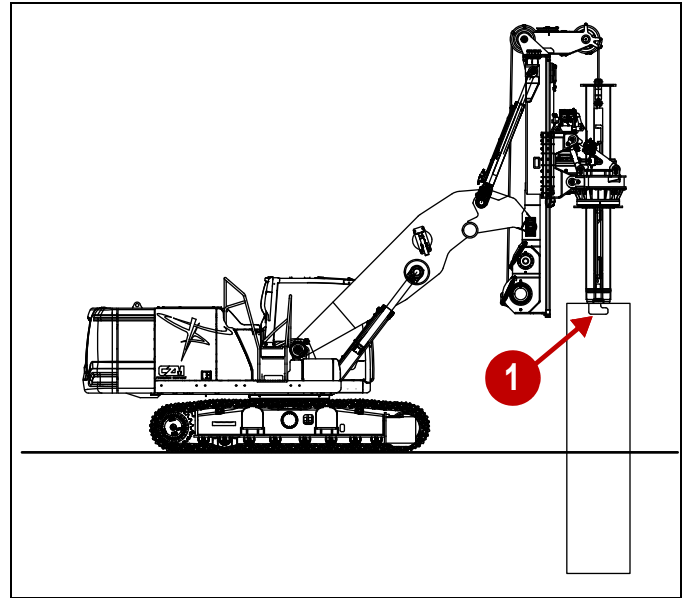

Figure 7-103

0000457

4. Hook the kelly bar (1) to the casing and drive the casing down into the ground until the top is flush with the ground level.
5. It may be necessary to change back to an auger, drill further inside the casing and then change back to the cross bar.

NOTICE

Depending on the diameter of the casing, it might be possible to add a cross bar to the bottom of the rotary, avoiding having to remove the auger for driving the casing.

The casing only secures the top part of the hole. A polymer or bentonite additive may be necessary to stabilize the bottom section of the hole.

OPERATION

Parking*

Stopping the Machine*

SMCS Code: 7000

WARNING

Leaving the machine unattended when the engine is running may result in personal injury or death. Before leaving the machine operator station, neutralize the travel controls, lower the work tools to the ground and deactivate all work tools, and place the lever for the hydraulic lockout control in the LOCKED position.

NOTE: *There may be regulations that define the requirements for the operator and/or support personnel to be present when the engine is running.*

Park on a level surface. If the machine must be parked on a grade, chock the tracks securely.

NOTE: *The swing parking brake is automatically applied when the machine is stopped. The swing parking brake is released when the engine is running and the joystick is activated.*

1. Turn the engine speed dial counterclockwise to reduce engine speed.
2. Release the travel levers/pedals to stop the machine.
3. Lower the work tool to the ground. Apply a slight downward pressure.
4. Move the hydraulic lockout control to the LOCKED position.

i06953413

Stopping the Engine*

SMCS Code: 1000; 7000

NOTICE

Stopping the engine immediately after it has been working under load can result in overheating and accelerated wear of engine components.

Refer to the following procedure to allow the engine to cool and to prevent excessive temperatures in the turbocharger housing, which could cause oil coking problems.

NOTICE

Never turn the battery disconnect switch to the OFF position while the engine is running. Serious damage to the electrical system may result.

1. Park the machine on level ground. Refer to Operation and Maintenance Manual, "Stopping the Machine" for the recommended procedure.
2. While the machine is stopped, run the engine for 5 minutes at low idle. Idling the engine allows hot areas of the engine to cool gradually.
3. Turn the engine start switch to the OFF position.

NOTE: If the "Regen Active" indicator is illuminated, do not shut off the engine. Refer to "Monitoring System" for more information on indicators.

Engine Shutdown Switch*

Turn the engine start switch to the OFF position. If the engine does not stop, perform the following procedure.

NOTICE

Always use the engine start switch to stop the engine. Use the engine stop control as an alternate method to stop the engine if the start switch fails.

NOTICE

- Perform a walk-around inspection after the actuation of a shutdown device.
- Take necessary corrective action to resolve the cause of the shutdown.
- Ensure that no additional damage has been done or could occur before returning to operation.

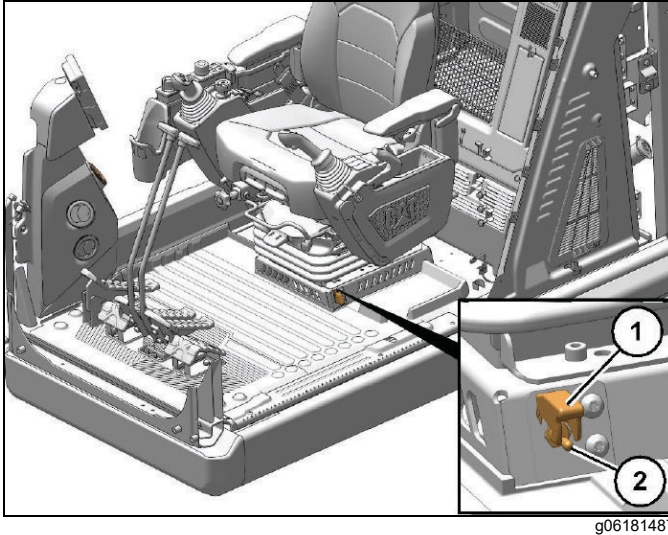

Figure 7-104

1. The switch is located below the left side of the operator seat.
2. Lift cover (1).
3. Push switch (2) upward. This should stop the engine and prevent the engine from being started again.
4. Return the switch to the original position. The engine will be enabled to start.

NOTE: Do not operate the machine again until the malfunction has been corrected.

5. Use the method that follows if the previous steps do not stop the engine.

Stop the Engine if an Electrical Malfunction Occurs*

Turn the engine start switch to the OFF position. If the engine does not stop, perform the following procedure.

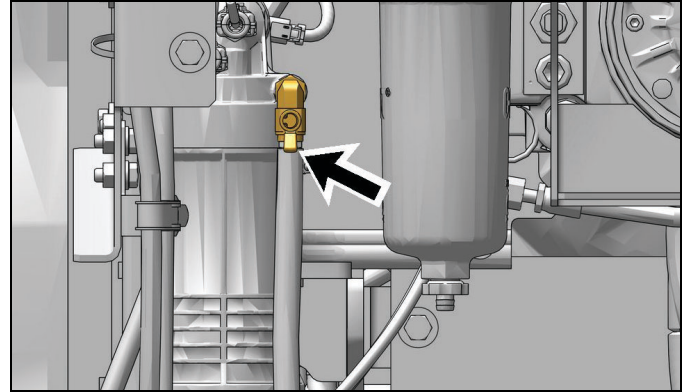

Figure 7-105

The engine fuel shutoff valve is located behind the right access door.

Shut off the fuel supply by turning the fuel valve clockwise. The engine will stop after consuming the fuel in the fuel line. The engine may continue to run for a few minutes.

Repair the engine before you restart the engine. The fuel system may need to be primed. See "Torque Specifications" on page 10-99 for instructions.

OPERATION

Parking*

SMCS Code: 7000

The hydraulic system controls remain pressurized if the accumulator is charged. This condition is true even when the engine is not running. The hydraulic control system pressure should decrease in a short time (approximately 1 minute). While the hydraulic controls maintain a charge, the hydraulic work tools and machine controls remain functional.

There can be residual pressure within the hydraulic system even when the accumulator is empty. Refer to this Operation and Maintenance Manual, "System Pressure Release" before any service is performed to the hydraulic system.

Machine movement that is sudden and unexpected will occur if any of the controls are moved. Machine movement that is sudden and unexpected, can cause personal injury or death.

Always move the hydraulic lockout control to the LOCKED position before you shut off the engine or immediately after the engine stops running.

Park the machine on a hard, level surface. If you must park the machine on a grade, chock the tracks of the machine.

Place the machine in the servicing position.

NOTE: Make sure that all work tools are in the recommended servicing position before servicing the machine.

Stop the engine.

Turn the engine start switch to the OFF position.

Turn the battery disconnect switch to the OFF position, if you do not intend on operating the machine for an extended period. This will prevent drainage of the battery. A battery short circuit, any current draw from certain components, and vandalism can cause drainage of the battery.

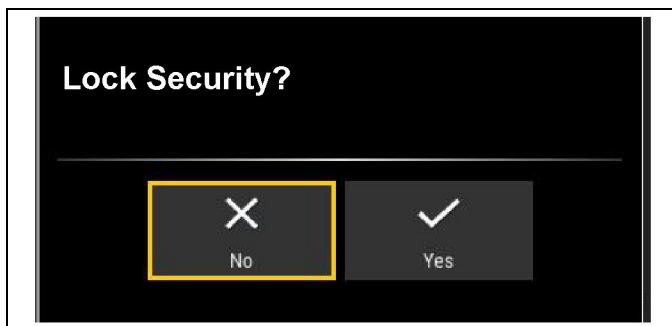

Figure 7-106

g06217247

NOTE: Do not turn off the battery disconnect switch until 5 seconds have elapsed after turning the engine start switch to the OFF position. Do not turn off the battery disconnect switch while the "Lock Security?" screen is displayed on the monitor. Both conditions would prevent the Diesel Exhaust Fluid (DEF) system from being purged and could cause the fluid to freeze in the lines.

Install barriers or lighting as required to prevent interference in road traffic.

Select places free of danger by flooding and other water damage.

Leaving the Machine*

SMCS Code: 7000

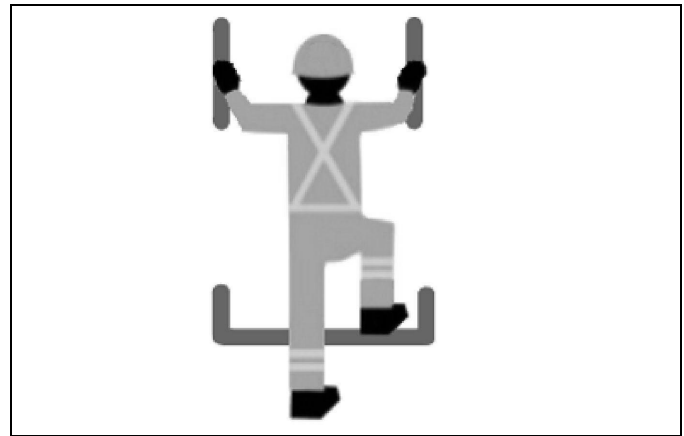

g06224270

Figure 7-107

1. Use the steps and the hand holds when you dismount. When you dismount, face the machine and use both hands.
2. Inspect the engine compartment for debris. Clean out any debris to avoid a fire hazard.
3. Remove all flammable debris from the front bottom guard through the access doors to reduce a fire hazard. Discard the debris properly.
4. Always turn the battery disconnect switch to the OFF position before leaving the machine.
5. If the machine will not be operated for a month or more, remove the battery disconnect switch key.
6. Lock all compartments and all vandalism covers (if equipped).

Machine Storage

The specified storage period of this machine is 1 year.

After the specified storage period has expired, contact CZM to inspect, repair, rebuild, install remanufactured, or install new components, and disposal options, and to establish a new specified storage period.

If a decision is made to remove the machine from service, refer to Decommissioning and Disposal*

Decommissioning and Disposal*

NOTE: 🌱 Improper waste disposal can harm the environment. Obey all local regulations for the decommissioning and disposal of materials.

When the product is removed from service, local regulations for product decommissioning will vary. Disposal of the product will vary with local regulations.

Rely on specialized companies able to carry out this operation in compliance with current regulations.

Utilize appropriate personal protective equipment when decommissioning and disposing of the product.

Consult CZM for additional information. Including information for component remanufacturing and recycling options.

(*) M0080149-08 ©2022 Caterpillar All Rights Reserved

Page Intentionally Left Blank

Chapter 8

Machine Setup for Drilling

Unload the Machine

⚠️ WARNING

When unloading the drilling rig, make sure the ground is stable and level.

Make sure that the ramps have proper inclination and are adequate for the load. Failure to follow this warning could result in death or serious injury.

1. Make sure the trailer is on level ground and the wheels are chocked.
2. Trailer ramps should be at a maximum angle of 15 degrees from level.
3. Make sure the trailer and ramps are clean.
4. Remove chocks and chains that secure the machine to the trailer.
5. Set any travel speed controls to low before loading the machine, Turn off any automatic engine speed controls.
6. Raise the boom slightly so the rotary/kelly bar do not come in contact with the trailer or ground.
7. Slowly back the machine onto the ramps.
8. When you drive over the loading ramp joint areas, be aware of shifting balances as the machine tips backward onto the ramps.

Machine Setup Steps

⚠️ WARNING

Any person assisting the operator in machine setup must:

- Keep fingers and other body parts away from pinch points to prevent crushing injuries while the drilling rig is in operation.
- Never stand under or allow feet or other body parts under drilling rig components to avoid crushing hazards.
- Remain within the operator's field of vision when the machine is being moved or operated.
- Understand how to communicate with the operator using standard hand signals.

Failure to follow these warnings could result in death or serious injury.

Prepare the machine for drilling after unloading it at the work site. Some procedures must be done with the drilling rig in motion, with the operator on board, and with help of an assistant, who must perform steps directly on the machine.

⚠️ WARNING

- During machine setup, machine operators are responsible for ensuring the safety of their assistant.
- To prepare for drilling, move the drilling rig on to stable and even ground.

Failure to follow these warnings could result in death or serious injury.

The main steps for drilling setup are:

- Positioning the machine at the drill site.
- Extending the undercarriage.
- Positioning the mast in the work position.
- Connecting the work tool.

MACHINE SETUP FOR DRILLING

Extend the Undercarriage Tracks

⚠ WARNING

The undercarriage must be extended before operating the drilling rig. Failure to extend the undercarriage could cause a machine tip over resulting in death, severe injury, and damage to the machine.

⚠ CAUTION

If the soil type makes track extension difficult, move the undercarriage forward and backward while trying to extend or retract the tracks. Do not put excess stress on the track extension cylinders. Failure to follow this caution may result in damage to the machine.

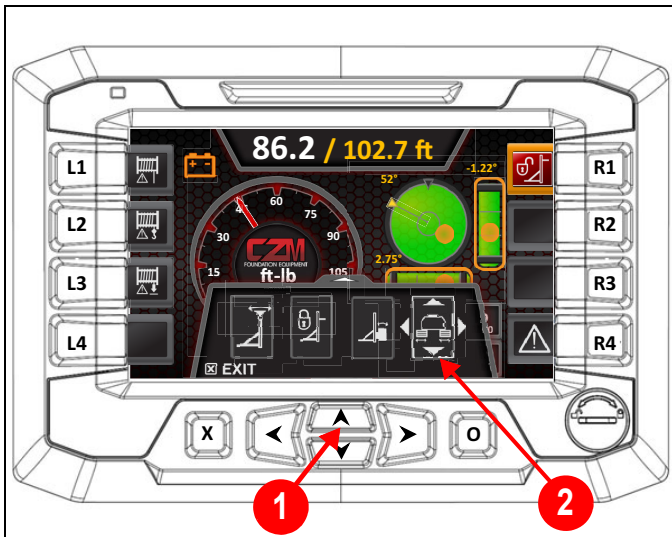

Figure 8-1

0000346

1. On the CZM monitor's Second Screen, press the up arrow button (1) to display the machine setup options. See "Second Screen Machine Setup Functions" on page 6-22.

2. Select the extend carriage option (2).

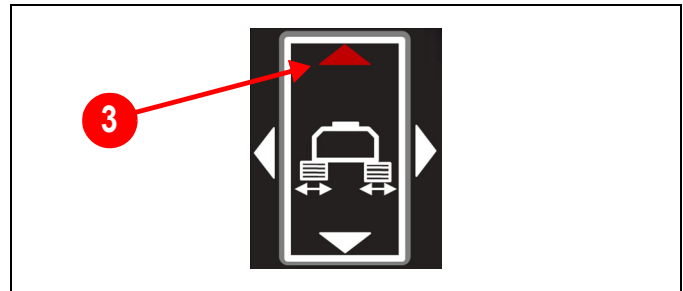

Figure 8-2

0000173

3. When selected, the extend carriage function will display four arrows. Use the up arrow button (1) or touch near the up arrow (3) on the screen to fully extend the undercarriage tracks.

Place the Mast in the Work Position

⚠️WARNING

- Do not rotate the mast when the undercarriage is retracted.
- Do not rotate the mast when it is in the transport position.

Failure to follow these warnings could result in death, serious injury, and/or damage to the machine.

1. Extend the undercarriage.

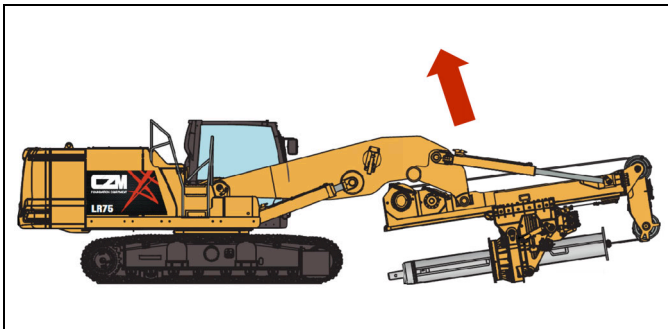

Figure 8-3

0000953

2. Slowly elevate the boom.

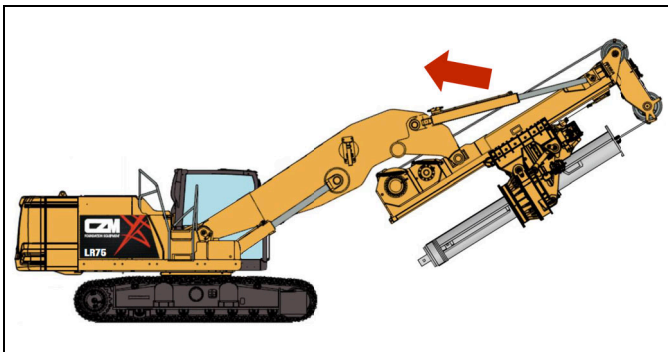

Figure 8-4

0000954

3. Rotate the mast until it is perpendicular to the ground.

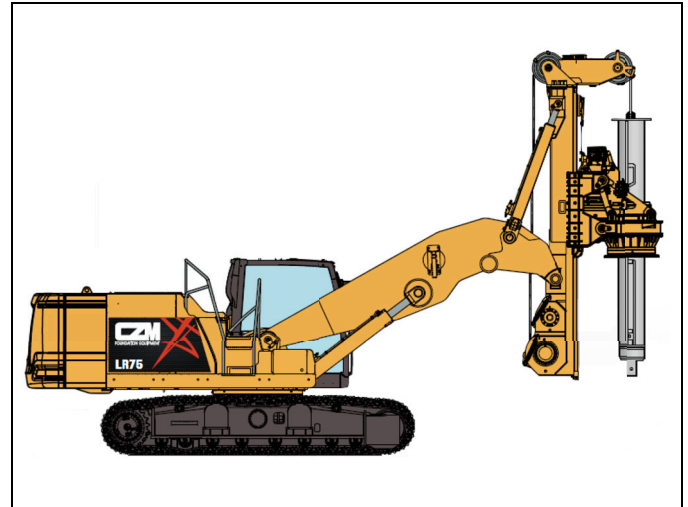

Figure 8-5

0000955

4. The drilling rig is now ready for attaching the work tool.

Attach the Work Tool

⚠️WARNING

Make sure any assistant helping to connect the work tool has left the danger zone while aligning the work tool with the kelly bar. There is a risk of the work tool falling over resulting in death or serious injury.

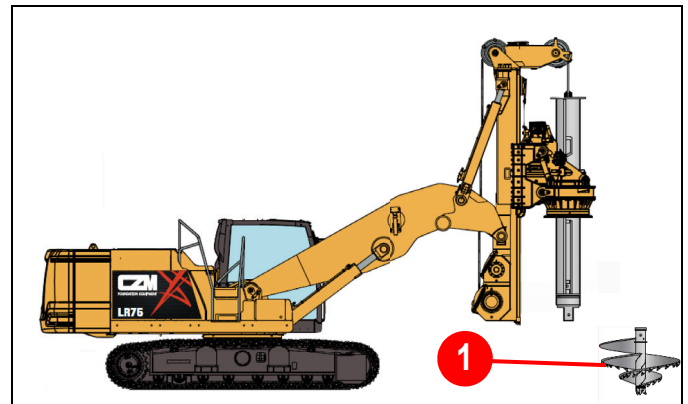

Figure 8-6

0000956

1. Use the auxiliary winch to secure the work tool (1) with the square joint (tool box) facing up.

MACHINE SETUP FOR DRILLING

2. Move the drilling rig to align the kelly bar with the work tool.

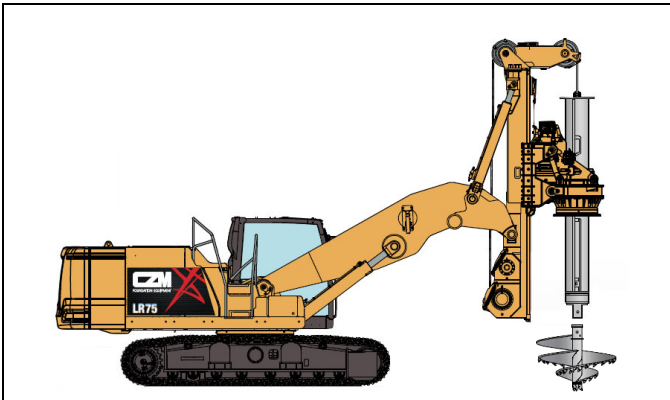

Figure 8-7

0000940

3. Lower the kelly bar and rotate the rotary as needed to align the kelly bar connector with the work tool connector.

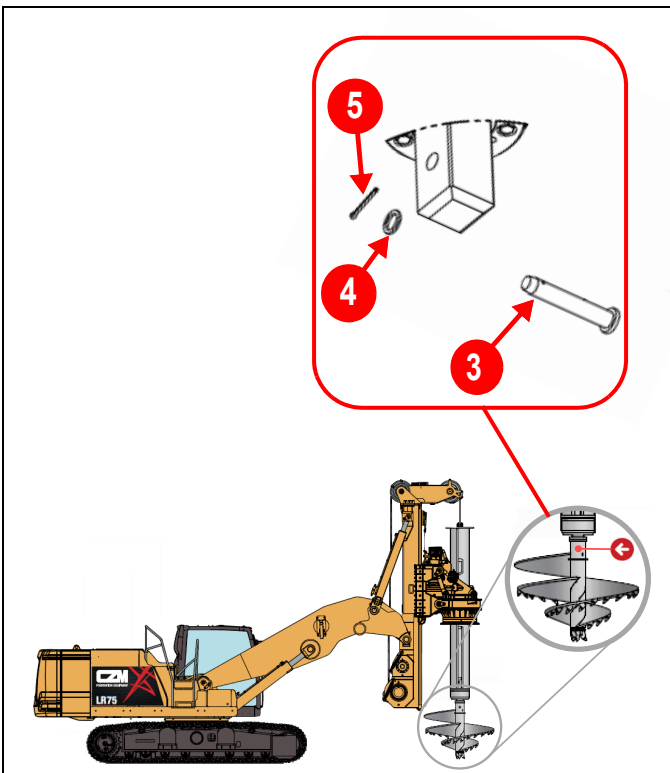

Figure 8-8

0000939

4. Install the pin (3), washer (4), and safety pin (5) to secure the work tool to the kelly bar.
5. The drilling rig is now ready for drilling operations.

Chapter 9

Loading Machine for Transport

Machine Setup Steps

⚠️ WARNING

Any person assisting the operator in machine setup must:

- Keep fingers and other body parts away from pinch points to prevent crushing injuries while the drilling rig is in operation.
- Never stand under or allow feet or other body parts under drilling rig components to avoid crushing hazards.
- Remain within the operator's field of vision when the machine is being moved or operated.
- Understand how to communicate with the operator using standard hand signals.

Failure to follow these warnings could result in death or serious injury.

Prepare the machine for transport. Some procedures must be done with the drilling rig in motion, with the operator on board, and with help of an assistant who must perform steps directly on the machine.

The main steps for transport setup are:

- Disconnecting the work tool.
- Positioning the mast in the transport position.
- Retracting the undercarriage.

Disconnect the Work Tool

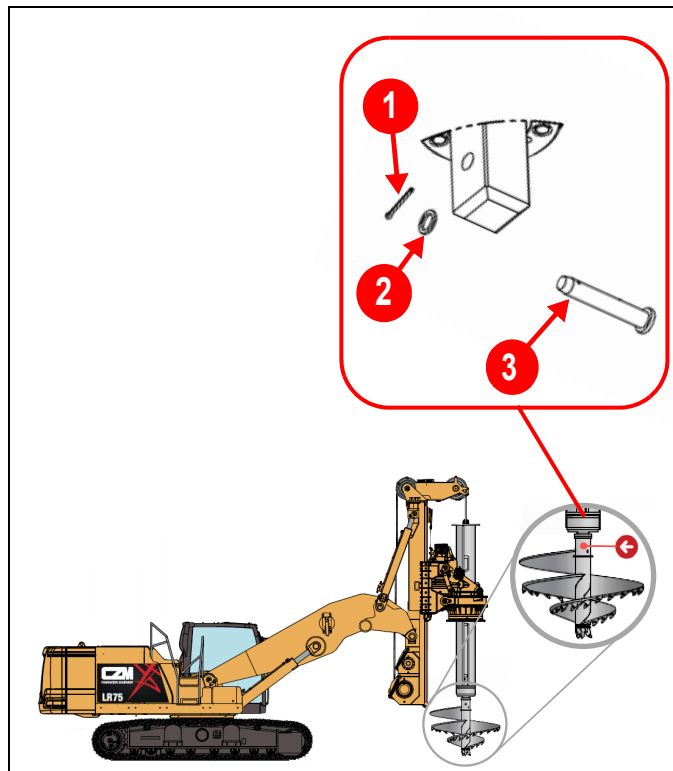

Figure 9-1

0000939

1. Lower the kelly bar until the work tool touches the ground.
2. Remove the safety pin (1), washer (2), and pin (3) that secure the work tool to the kelly bar.
3. If work tool is possibly unstable, add support to prevent tipping when the kelly bar is removed.

⚠️ WARNING

Make sure any assistant helping to disconnect the work tool has left the danger zone before raising the kelly bar. There is a risk of the work tool falling over resulting in death or severe injury.

4. Make sure all personnel are clear of the work area danger zone.

LOADING MACHINE FOR TRANSPORT

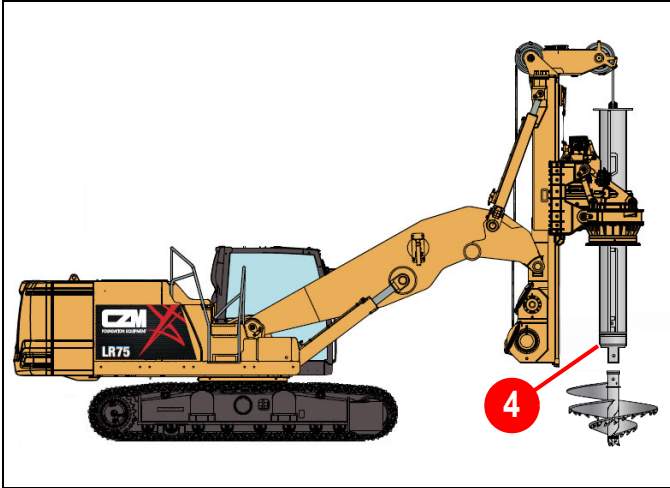

Figure 9-2

0000940

5. Slowly lift the kelly bar (4) to release the tool.

WARNING

All movements of the drilling rig during tool removal must be done slowly. There is a risk of the work tool falling over resulting in death or severe injury.

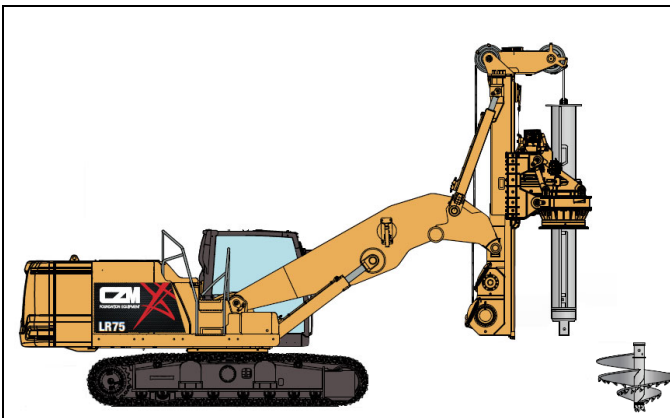

Figure 9-3

0000941

6. Back the machine away from the tool.

Place the Mast in the Transport Position

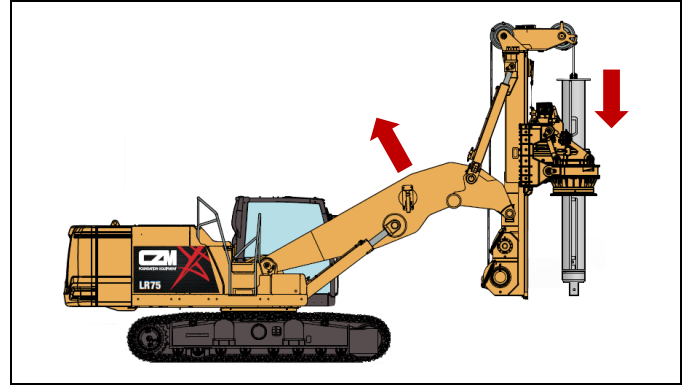

Figure 9-4

0000942

1. Raise the boom.

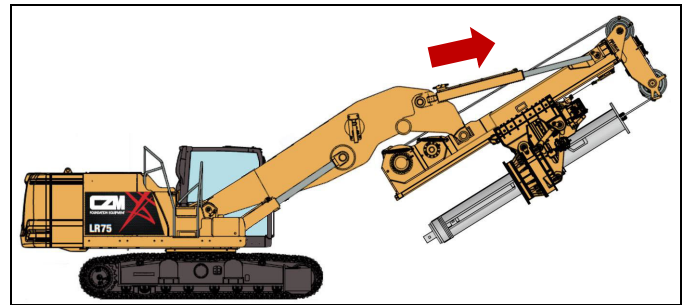

Figure 9-5

0000943

2. While keeping the boom slightly raised position, rotate the mast until the mast hydraulic cylinder reaches its stop limit.

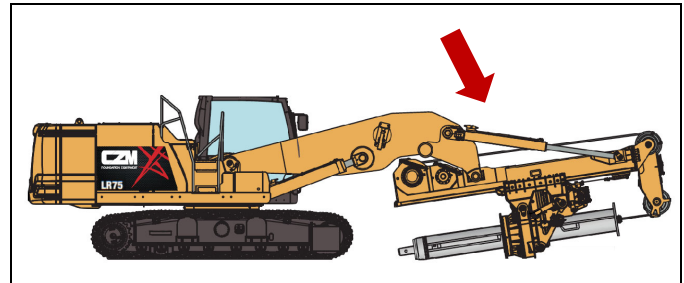

Figure 9-6

0000944

3. Lower the boom until it reaches its transport position.

Retract the Undercarriage

Retract the undercarriage tracks as follows:

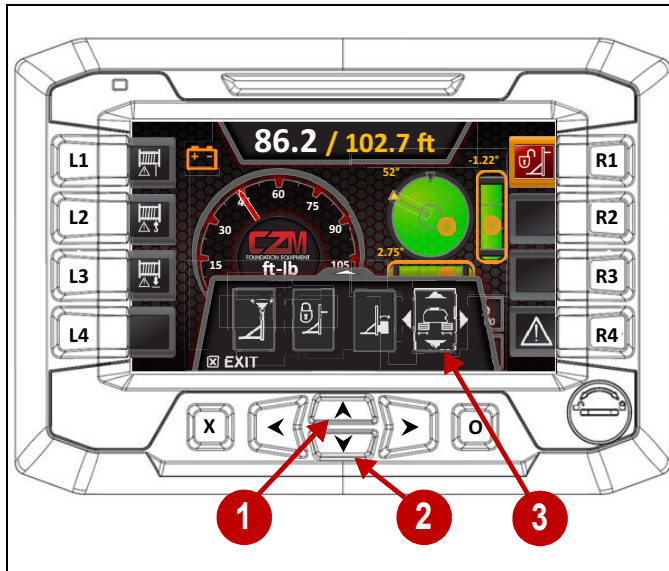

Figure 9-7

0000346

4. On the monitor, press the up arrow button (1) from the main screen to display the settings options.
5. Select the undercarriage function (3).

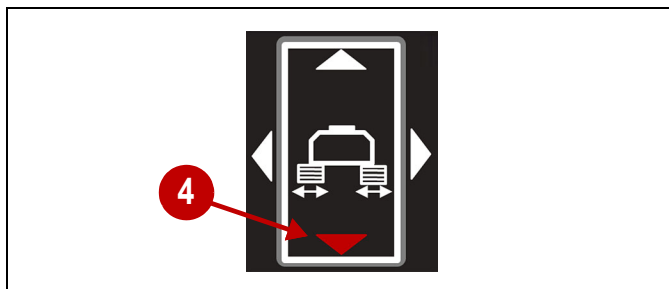

Figure 9-8

0000169

6. When selected, the undercarriage function will display four arrows.
7. Use the down arrow button (2) or touch near the down arrow (4) on the display to retract the tracks.

Shipping the Machine*

SMCS Code: 7000; 7500

⚠ WARNING

Automatic Engine Speed Control (AEC) will increase engine speed automatically when you operate the control levers and/or travel pedals with AEC switch on.

When loading the machine from the truck or working in close quarters always turn AEC switch off to prevent any possibility of sudden movement of the machine, which could result in serious injury or death.

Set the travel speed control switch to LOW before loading the machine. Never operate this switch when loading the machine on a trailer.

Investigate the travel route for overpass clearances. Make sure that there will be adequate clearance for the machine.

Remove ice, snow, or other slippery material from the loading dock and from the truck bed before you load the machine onto the transport machine. Removing ice, snow, or other slippery material will help to prevent the machine from slipping in transit.

NOTE: Obey all laws that govern the characteristics of a load (height, weight, width, and length). Observe all regulations that govern wide loads.

Choose the flattest ground when you load the machine the machine.

1. Before you load the machine, chock the trailer wheels or the rail car wheels.
2. When you use loading ramps, make sure that the loading ramps have adequate length, adequate width, adequate strength, and an adequate slope.
3. Maintain the slope of the loading ramps within 15 degrees of the ground.
4. Position the machine so that the machine can drive straight up the loading ramps. The final drives should be toward the rear of the machine. Do not operate the control levers while the machine is on the loading ramps.
5. When driving over the loading ramp joint areas, maintain the balance point of the machine.

LOADING MACHINE FOR TRANSPORT

6. To prevent rolling of the machine or sudden movement of the machine, perform the following items:
 - Chock both tracks.
 - Install sufficient tie-downs at several locations.
 - Fasten wire cables.

NOTE: When the engine is stopped, the swing parking brake is automatically applied. The swing brake prevents the upper structure from rotating.

NOTICE

In freezing weather, protect the cooling system with antifreeze, to the lowest outside expected temperature on the travel route. Or, drain the cooling system completely.

Securing the Machine*

SMCS Code: 7000

WARNING

Do not transport the machine if there is a malfunction of the swing parking brake system. The machine may swing during transportation if the swing parking brake system is not functioning properly which could result in injury or death. Contact CZM after-sales support for service.

Comply with any laws that govern the characteristics of a load (length, width, height, and weight).

1. Move the hydraulic lockout control to the LOCKED position.
2. Turn the engine start ring to the OFF position or press button to stop engine.
3. Turn the battery disconnect switch to OFF and remove the disconnect switch key.
4. Lock the door and the access covers. Attach any vandalism protection.
5. Cover the exhaust opening.

NOTICE

Do not allow the turbocharger to rotate while the engine is not operating. Damage to the turbocharger can result.

NOTE: Before you unload the drilling rig from the transport machine, remove the protective covering from the exhaust opening.

6. Chock the tracks and secure the machine with tie-downs. Make sure that you use the proper rated wire cable.

Use the front towing eyes on the lower frame, the rear towing eyes on the lower frame, and the rear towing eye that is on the upper frame.

Securely fasten all loose parts and all removed parts to the trailer or to the rail car.

Tying Down the Machine*

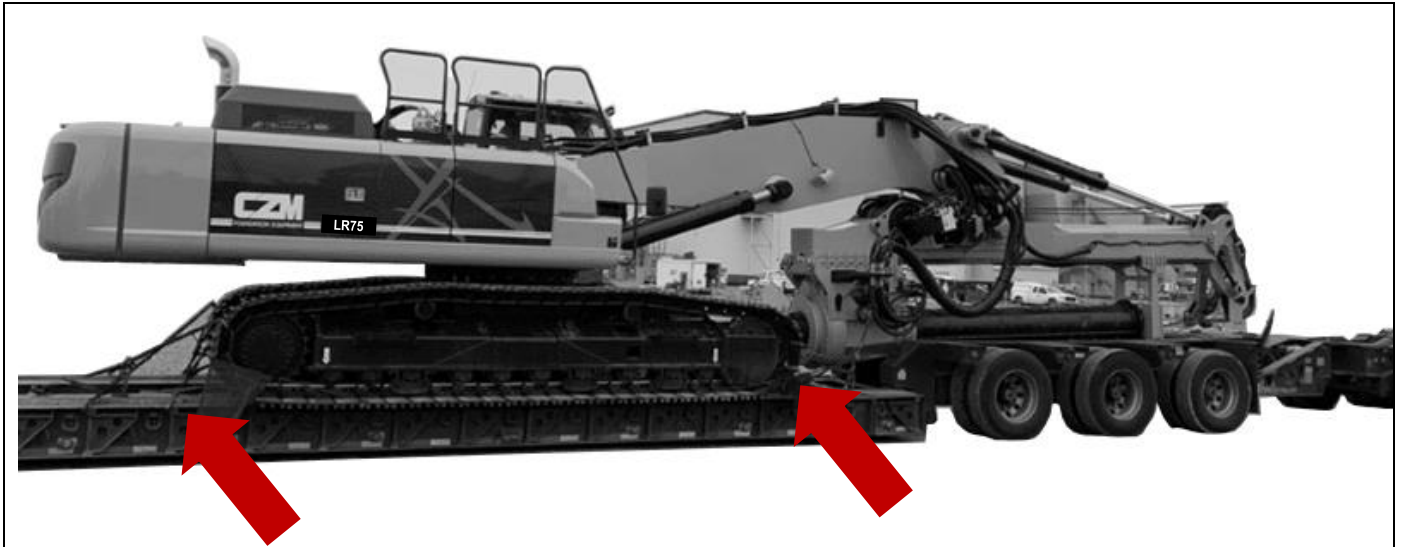

Figure 9-9

0000403



Tie Down Point – To tie down the machine, attach the tie-downs to the tie-down points.

See “Technical Specifications” on page 4-1 for specific weight information.

1. Use proper rated cables and shackles for tying down the machine.
2. Use the rear eyes and the front eyes that are provided on the lower frame to fasten tie-downs. Use corner protectors for sharp corners.
3. Move the hydraulic lockout control to the LOCKED position.
4. If there is a requirement of diagonal lashing for tying down, use the proper tie-down point on the lower frame. Set the lashing angle which is on the longitudinal axis of the machine and the cable, at 30 to 50 degrees.
5. Keep the transport vehicle surface clean (for example, trailer deck).

For steel deck transport vehicles use skid inhibiting or anti-slip mats (for example, rubber mats) with a friction coefficient of at least 0.3.

There are two methods that can be used to tie down a machine. Local and/or regional regulations will determine which method to use.

Obey all local and regional governmental regulations.

LOADING MACHINE FOR TRANSPORT

Frictional and Direct Lashing*

When allowed, a combination of frictional lashing and direct lashing is the preferred method to tie down a machine.

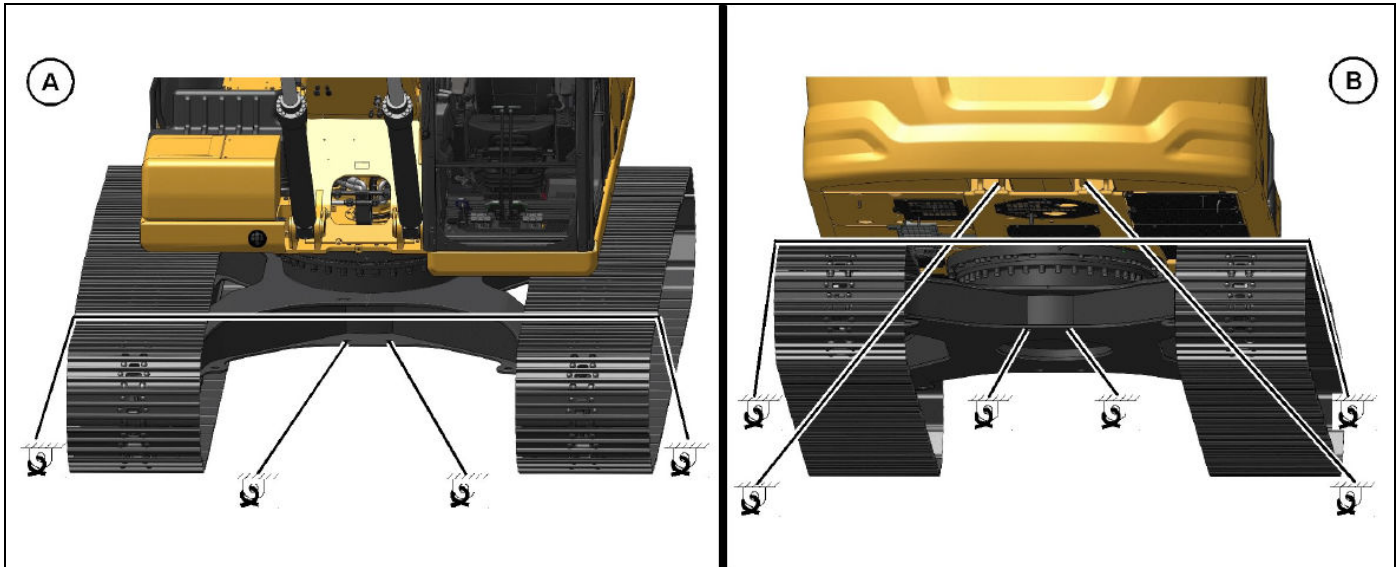

Figure 9-10

g06184145

A) Front of the Machine

B) Rear of the Machine

Diagonal Lashing*

In areas where frictional lashing is not allowed, diagonal lashing can be used as shown below.

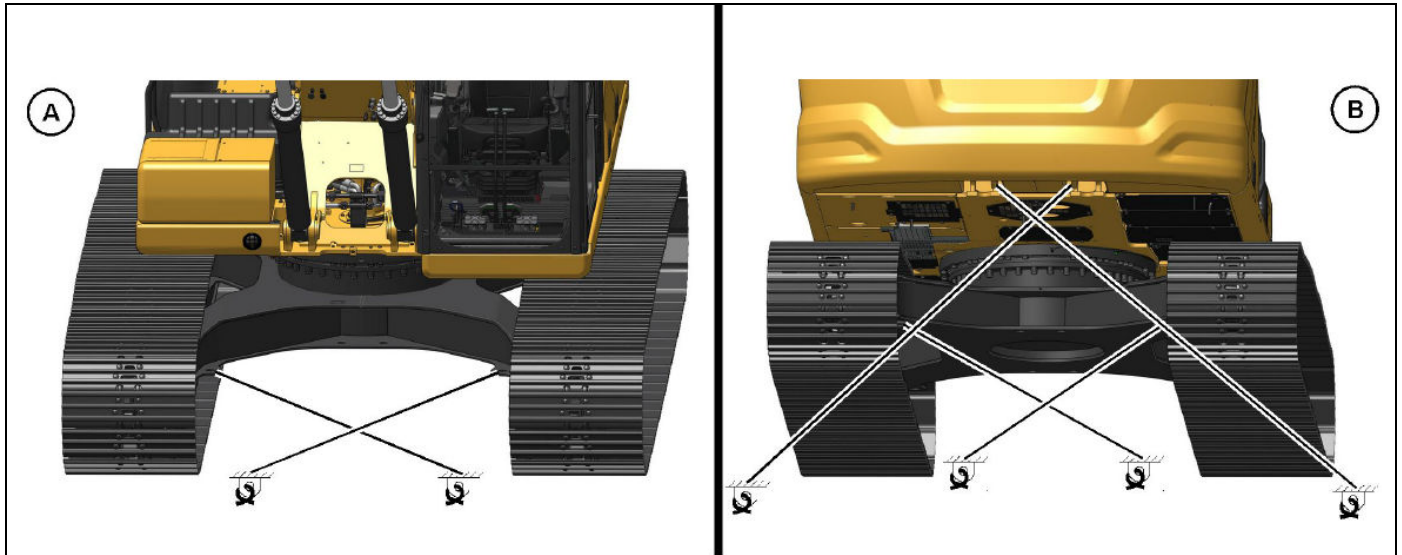

Figure 9-11

g06184360

A) Front of the Machine

B) Rear of the Machine

WARNING

Only use properly rated cables and slings attached to the lift points provided on the machine. Failure to properly secure the machine may result in sudden shifting of the load resulting in death, serious injury, or property damage.



Figure 9-12

g06184026



Lifting Point – To lift the machine, attach the lifting devices to the lifting points.

NOTICE

Use the four lifting points (1) identified by the decal (2). Do not use foot steps as lifting points.

See “Technical Specifications” on page 4-1 for machine transport weights. Make sure the lifting machine and straps are suitable for handling this weight.

1. Make sure the machine mast is in the transport position and is secured.
2. The machine center of gravity is located at the center of the swing gear.
3. Use proper rated cables and slings for lifting. The crane should be positioned so that the machine is lifted parallel to the ground.
4. To prevent contact with the machine, lifting cables should have a spreader bar of sufficient length.
5. Make sure the hydraulic lockout control is in the LOCKED position.
6. If the base machine has a full length roller guard, remove the guard.
7. Pass the lifting cable between the first and second bottom rollers, under the machine, and out the first and second rollers on the opposite track.
8. Repeat Step 7 for the second lifting cable on the other end of the track.
9. Apply the proper protector to prevent machine/wire damage and slippage. Make sure that the rollers are not affected by the lifting cable.

(*) M0080149-08 ©2022 Caterpillar All Rights Reserved

Page Intentionally Left Blank

Chapter 10

Service Recommendations

Maintenance Recommendations

Before making any adjustments or servicing the drilling rig, enable all the safety devices available. Take into consideration if it is necessary to inform personnel involved in the procedure or operating in the vicinity of the drilling rig of your intended actions. Provide suitable signs around the affected area and prevent access to any devices whose operation might give rise to unpredictable, hazardous conditions that are a risk to personal health and safety.

WARNING

Unless specified otherwise, all maintenance must be carried out with:

- The engine off.
- The machine key removed and stored in a safe place.
- All the machine's moving parts in the most suitable position to facilitate the action that has to be taken and to avoid any additional risks.

The person authorized to service the machine must consider all the actions required to guarantee the safety of all parties involved and maintain compliance with current rules and regulations concerning occupational safety. Replace excessively worn parts only with original equipment spares. Failure to follow this warning may result in death or serious injury.

WARNING

The operator can override safety limit switches if required for the assembly or disassembly of machine components. When safety limit switches are overridden, some operations are possible which may cause overturning or damage to the machine. Extra care and observation must be taken for operations without functioning limit switches. Any limit switch override must be removed once the maintenance task is completed. Failure to follow this warning may result in death or serious injury.

CAUTION

Use only the oils and greases recommended by CZM and the base machine manufacturer. This will ensure the safe and smooth operation of the drilling rig. Failure to use recommended oils and greases can cause improper operation and damage to the machine.

NOTICE

 Care must be taken to ensure that fluids are contained during performance of inspection, maintenance, testing, adjusting, and repair of the machine. Be prepared to collect the fluid with suitable containers before opening any compartment or disassembling any component containing fluids.

Contact the CZM After Sales Department for tools and supplies suitable to collect and contain fluids on CZM products.

Dispose of all fluids according to local regulations and mandates.

SERVICE RECOMMENDATIONS

Welding on Machines and Engines with Electronic Controls*

SMCS Code: 1000; 7000

⚠ WARNING

Do not weld on any protective structure. If it is necessary to repair a protective structure, contact the CZM After Sales Department. Failure to follow this warning could result in death or serious injury.

⚠ CAUTION

Do not use electrical components (ECM or sensors) or electronic component grounding points for grounding the welder. Failure to follow this caution could result in damage to the drilling rig.

Proper welding procedures are necessary to avoid damage to the electronic controls and the bearings. When possible, remove the component that must be welded from the machine or the engine and then weld the component.

If you must weld near an electronic control on the machine or the engine, temporarily remove the electronic control to prevent heat-related damage. The following steps should be followed to weld on a machine or an engine with electronic controls:

1. Turn off the engine.
2. Turn the engine's start switch to the OFF position.
3. Clamp the ground cable from the welder to the component that will be welded. Place the clamp as close as possible to the weld. Make sure that the electrical path from the ground cable to the component does not go through any bearing. Use this procedure to reduce the possibility of damage to the following components:
 - Bearings of the drive train.
 - Hydraulic components.
 - Electrical components.
 - Other components of the drilling rig.
4. Protect any wiring harnesses and components from the debris and the spatter which is created by welding.
5. Use standard welding procedures to weld the materials together.

Severe Service Application*

SMCS Code 1000

An engine that operates outside of normal conditions is operating in a severe service application.

An engine that operates in a severe service application may need more frequent maintenance intervals in order to maximize the following conditions:

- Reliability
- Service life

The number of individual applications causes the impossibility of identifying all of the factors which may contribute to severe service operation. Consult CZM for the unique maintenance that may be necessary for your engine.

An application is a severe service application if any of the following conditions apply:

Severe Environmental Factors*

- Frequent operation in dirty air.
- Frequent operation at an altitude which is above 1525 m (5000 ft).
- Frequent operation in ambient temperatures which are above 32° C (90° F).
- Frequent operation in ambient temperatures which are below 0° C (32° F).

Severe Operating Conditions*

- Frequent operation with inlet air which has a corrosive content.
- Operation with inlet air which has a combustible content.
- Operation which is outside of the intended application.
- Operation with a plugged fuel filter.
- Extended operation at low idle (more than 20% of hours).
- Frequent cold starts at temperatures below 0°C (32°F).
- Frequent dry starts (starting after more than 72 hours of shutdown).
- Frequent hot shutdowns (shutting down the engine without a minimum of 2 minutes to 5 minutes of cool-down time).
- Operation above the engine-rated speed.
- Operation below the peak torque speed.

- Operating with fuel that does not meet the standards for distillate diesel fuel as stated in “Fluids and Lubricants” on page 10-11.
- Operating with a blend of distillate fuel which contains more than 20 percent biodiesel.

Improper Maintenance Procedures*

Maintenance procedures which may contribute to a severe service application:

- Inadequate maintenance of fuel storage tanks from causes such as excessive water, sediment, and microorganism growth.
- Extending maintenance intervals beyond the recommended intervals.
- Using fluids that are not recommended in “Fluids and Lubricants” on page 10-11.
- Extending maintenance intervals for changing the engine oil and engine coolant.
- Extending maintenance intervals for changing air filters, oil filters, and fuel filters.
- Failure to use a water separator. Using filters that are not recommended by CZM.
- Storing the engine for more than 3 months but less than 1 year.

Access Door and Cover Locations

SMCS Code: 726A-CH

Engine Hood*

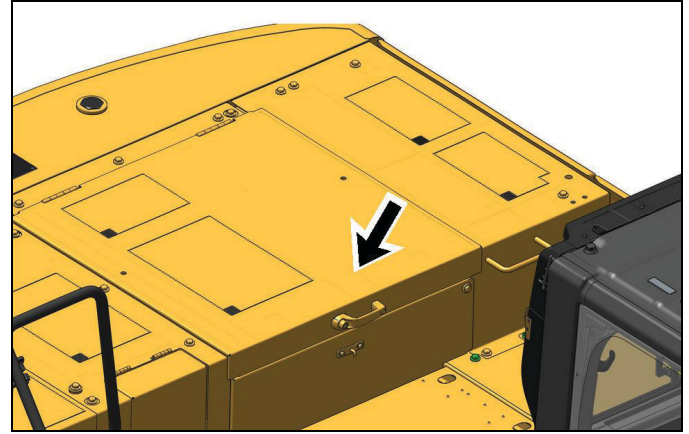

Figure 10-1

g06225770

Allows access to the engine and coolant tank.

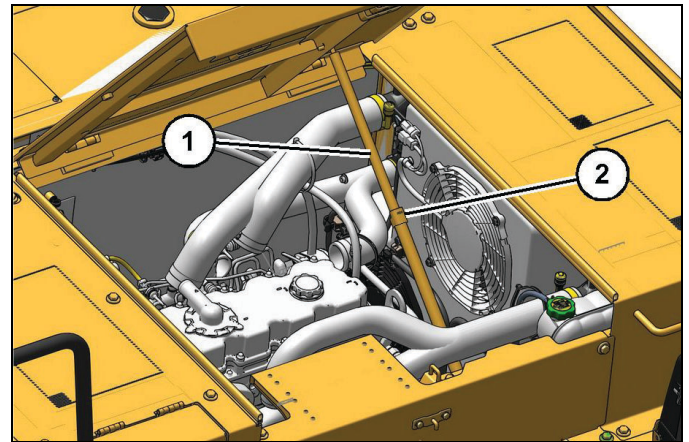

Figure 10-2

g06225771

1. Open the engine hood.
2. The gas spring (1) will lock in place to hold the engine hood open.

⚠ WARNING

Operation of the push button release for the engine hood:

- When closing the engine hood, only operate the push-button release by hand.
- Do not operate the push-button release by foot. Operation of the push-button release by foot could result in damage to the gas spring of the closing mechanism and/or personal injury.

SERVICE RECOMMENDATIONS

- Be sure to remove hands from the push-button release before completely closing the engine hood.

Failure to follow this warning can result in serious injury.

NOTICE

Do not apply pressure to the engine hood when open.

3. To close the engine hood, support the engine hood by the door handle. Press the push-button release (2) to unlock the gas spring. Release the push button and slowly close the engine hood.

Engine Service Door*

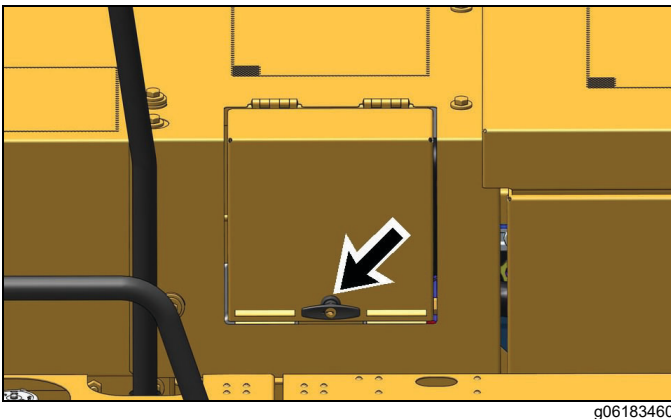
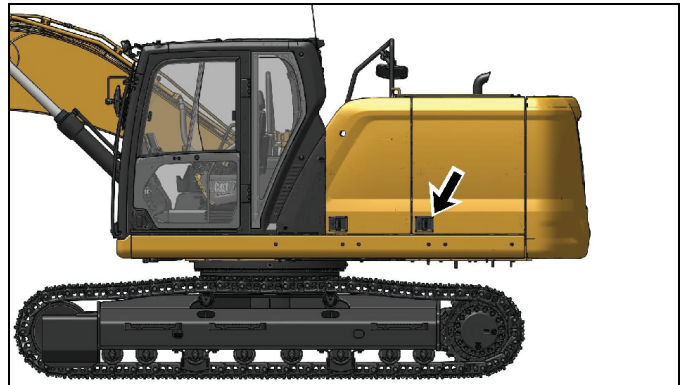

Figure 10-3: Engine Oil Level-Access Door

Allows access to the engine oil filler cap and the upper dipstick.

Left Rear Access Door*



g06179792

Figure 10-4: Left Rear Door

Allows access to the:

- Coolant sample port
- Coolant drain
- Cooling cores
- Power fuses
- Battery disconnect switch
- Coolant reservoir

Left Front Access Door*



g06181546

Figure 10-5: Left Front Door

Allows access to:

- Engine air filter
- Batteries
- Window washer reservoir

Right Side Access Door*

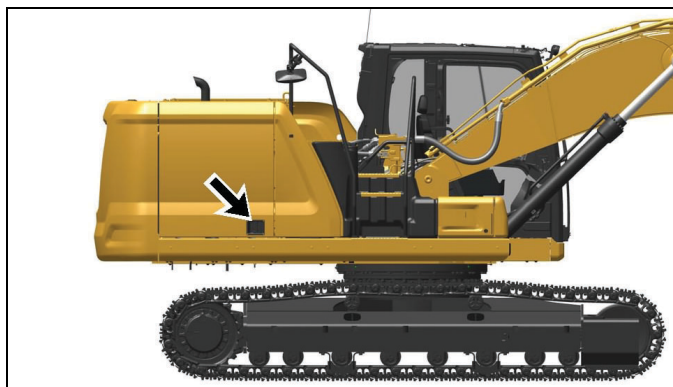

g06182545

Figure 10-6: Right Access Door

Allows access to the:

- Engine oil filter
- Engine oil sampling port
- Ground-level dipstick
- Hydraulic pump
- Fuel filters
- Refueling pump
- Fuel tank drain valve
- Hydraulic tank sight gauge

Right Front Access Door

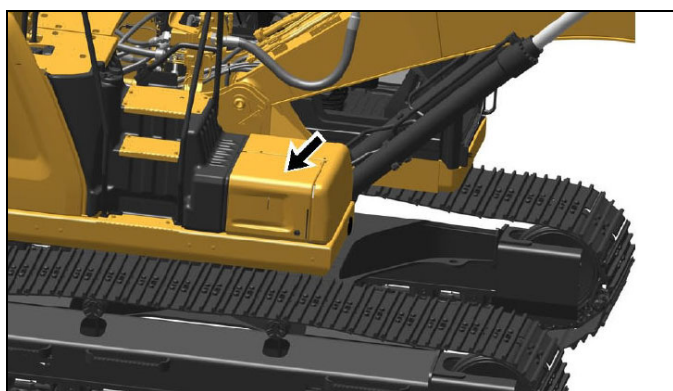

g06183098

Figure 10-7: DEF Compartment

Allows access to the Diesel Exhaust Fluid (DEF) tank.

Prepare the Machine for Maintenance*

SMCS Code: 1000; 7000

WARNING

Personal injury can result from hydraulic oil pressure and hot oil.

Hydraulic oil pressure can remain in the hydraulic system after the engine has been stopped. Serious injury can be caused if this pressure is not released before any service is done on the hydraulic system.

Make sure all of the attachments have been lowered and hydraulic oil is cool before removing any components or lines. Remove the oil filler cap only when the engine is stopped, and the filler cap is cool enough to touch with your bare hand.

NOTICE

! Care must be taken to ensure that fluids are contained during performance of inspection, maintenance, testing, adjusting, and repair of the machine. Be prepared to collect the fluid with suitable containers before opening any compartment or disassembling any component containing fluids.

Contact the CZM After Sales Department for tools and supplies suitable to collect and contain fluids on CZM products.

Dispose of all fluids according to local regulations and mandates.

NOTE: Permit only one operator on the machine. Keep all other personnel away from the machine or in view of the operator.

1. Park the machine on a dry, level, solid surface that is free of any debris.

NOTE: The surface must be solid enough to support the weight of the machine and any tooling that is used to support the machine.

2. Engage the park brake. Place wheel blocks in front of and behind the wheels or tracks.
3. Lower all work tools to the ground.
4. Stop the engine.

SERVICE RECOMMENDATIONS

5. Release the pressure in the hydraulic system. Refer to “Release of Hydraulic Pressure from the Main Hydraulic System*” on page 10-66 for additional information.
6. Perform a visual inspection first:
 - If the visual checks are completed but the problem has not been identified, perform operational checks.
 - If the problem has not been identified, perform instrument tests. This procedure will help to identify system problems.

Maintenance Plan

The LR95 drilling rig must be serviced according to the Maintenance Interval Schedule. Any abnormal noise or behavior during work must be investigated in order to prevent a failure or accidents due to an equipment malfunction.

The base machine must be serviced according to the manufacturer recommendations. See the following maintenance schedule.

NOTE: *Print or make a copy of this schedule and mark items as being completed. Sign and date the schedule and retain for your maintenance records.*

Maintenance Interval Schedule	
Model: LR95	Serial Number:
When Required	
Air conditioner/cab heater filter (recirculation) – inspect/replace	Fuel tank strainer – clean
Battery electrolyte level – check	Fuses – replace
Battery or battery cable – inspect/replace	High intensity discharge lamp (HID) – replace
Cab air filter (fresh air) – clean/replace	Oil Filter – inspect
Camera – clean	Radiator, aftercooler and oil cooler cores – clean
Condenser (refrigerant) – clean	Rollover protective structure (ROPS) – inspect
DEF filler screen – clean	Track adjustment – adjust
Diesel exhaust fluid – drain	Undercarriage – check
Diesel exhaust fluid – fill	Window washer reservoir – fill
Engine air filter primary and/or secondary element – replace	Window wiper – inspect/replace
Decals – clean	Windows – clean
Fuel system – prime	
Signature/Date:	
Every 10 Hours or Daily	
Machine Base	
Engine oil level – check	Inspect for missing or damaged parts
Cooling system coolant level – check	Fuel system water separator – drain
Fuel tank – drain water/sediment	Hydraulic system oil level – check
Indicators and gauges – test	Seat belt – inspect
Track adjustment – inspect	Inspect for loose or damaged bolts
Travel alarm – test	
Rotary and Rotary Guide	
Rotary – clean externally	Oil level – check
Check for wear or damage	Rotary (8 points) – lubricate
Check for oil leaks	Rotary guide wear pads – lubricate
Inspect for loose bolts	
Main and Auxiliary Winch	
Check wire rope for wear or damage	Main winch wire rope – lubricate
Limit switches – check function	
Hydraulic System	
Hydraulic cylinders – inspect for leaks	Hydraulic reservoir – check oil level
Oil cooler – check	
Signature/Date:	

SERVICE RECOMMENDATIONS

Every 50 Hours or Weekly	
Mast and Components	
Mast – inspect the entire length for cracks	Lubricate boom arm pins (16 points)
Check all pins, bolts and nuts for tightness	Head mast joint pin – lubricate
Wire rope – check fit on head mast pulleys	Head mast pulley pins (3 points) – lubricate
Mast guides – lubricate the full length	Inspect boom for cracks
Rotary and Rotary Guide	
Rotary internal keys – check	Check torque and integrity of all bolts
Rotary reducer oil level – check	Wear pads – adjust set screws
Main and Auxiliary Winch	
Gear box and brake oil levels of the main winch – check	Check cable land wear and integrity
Gear box and brake oil levels of the aux. winch – check	Check torque and bolt integrity.
Cable thimble/hook – inspect	
Kelly Bar and A-frame	
Check torque and integrity of set screws	A-frame bearings (3 points) – lubricate
Shock absorber – check for wear	Joint pin (2 points) – lubricate
A-frame wear pads – check	Cable swivel – lubricate and inspect
Hydraulic System	
Visually inspect hoses for wear and damage.	
Signature/Date:	
Every 150 Hours	
Auxiliary and Main Winches	
Initial oil change – drain and refill	Clean surfaces and air vent pathways
Check fasteners	
Signature/Date:	
Every 250 Hours or Monthly	
Machine Base	
Engine oil filter (first change only) – replace	Engine oil sample – obtain
Engine oil (first change only) – drain and refill	Final drive oil sample – obtain
Cooling system coolant sample (level 1) – obtain	
Mast and Components	
Head mast pulleys – inspect for damage and wear	
Rotary and Rotary Guide	
Collect oil sample for analysis	Rotary oil (first change only) – drain and refill
Main and Auxiliary Winch	
Main winch gear box oil (initial change only) – drain and refill	Main winch brake oil (initial change only) – drain and refill
Signature/Date:	
Every 500 Hours or Quarterly	
Machine Base	
Initial Cooling system coolant sample (level 2) – obtain	Fuel lift pump strainer – replace
Final drive oil – drain and refill (initial change only)	Hydraulic system oil sample – obtain
Swing drive oil – drain and refill (initial change only)	Swing bearing – lubricate
Engine oil and filter – change	Swing drive oil level – check
Final drive oil level – check	Swing drive oil sample – obtain
Rotary and Rotary guide	
Casing oil – drain and refill (first change only)	Oil sample for analysis – obtain
Signature/Date:	

SERVICE RECOMMENDATIONS

Every 1000 Hours or Annually	
Machine Base	
Battery – clean	Fuel system primary filter (water separator) element – replace
Battery hold-down – tighten	Fuel system secondary filter – replace
Swing drive oil – drain and refill	Diesel exhaust fluid filter – replace
Rotary and Rotary Guide	
General inspection to be done by a technician	Rotary keys – replace
Seals – check integrity	Rotary wear pads – replace
Rotary reducer oil – drain and refill	Pinion and crown – check
Rotary main case oil – drain and refill	Bearing – check
Main and Auxiliary Winch	
Main winch and brake oil – drain and refill	Auxiliary winch and brake oil – drain and refill
Main winch cable – inspect	Auxiliary winch cable – inspect
Hydraulic System	
Hydraulic system oil – drain and refill	Hydraulic tank oil filter – replace
Thorough inspection of hydraulic lines and connections for wear or damage – procedure to be performed by a technician	
Kelly Bar	
Disassemble the telescopic rod and inspect all elements for excessive wear and damage	
A-frame wear pads – replace	
Signature/Date:	
Every 2000 Hours	
Machine Base	
Final drive oil – drain and refill	Hydraulic system oil filter (return) – replace
Fuel cap filter – replace	Receiver dryer (refrigerant) – replace
Fumes disposal filter element – replace	Swing gear – lubricate
Signature/Date:	
Every Year	
Machine Base	
Cooling system coolant sample (level 2) – obtain	
Signature/Date:	
Every 3 Years	
Machine Base	
Seat belt – replace	
Signature/Date:	
Every 5000 Hours	
Machine Base	
Diesel exhaust fluid injector – replace	
Signature/Date:	

SERVICE RECOMMENDATIONS

Every 6000 Hours or 3 Years

Machine Base

Cooling system coolant extender (ELC) – add

Signature/Date:

Every 12,000 Hours or 6 Years

Machine Base

Cooling system – drain and refill

Signature/Date:

Fluids and Lubricants

Type	Lubricant	Manufacturer	Regular Ambient Temperature: -4°F – 104°F (-20°C – 40°C)	COLD WEATHER: -4°F – 104°F (-20°C – 40°C)	Hot Weather: 5°F – 122°F (-15°C – 50°C)	Biodegradable
A	Engine Oil	Shell	Shell Rotella T Triple Protection 10W-30			
		Caterpillar	CAT® DEO-ULS SYN-SAE10W-30	CAT® DEO-ULS Cold Weather SAE 0W-40		
		Mobil	Mobil Delvac 1 ESP 5W-40			
B	Pump Coupling (Oil)	Shell	Shell Rotella T Triple Protection 10W-30			
		Caterpillar	CAT® DEO-ULS SYN-SAE10W-30	CAT® DEO-ULS Cold Weather SAE 0W-40		
		Mobil	Mobil Delvac 1 ESP 5W-40			
C	Hydraulic Oil	Shell	Shell Spirax S4 CX 10W			
		Caterpillar	CAT® HYDO Advanced 10 SAE 10W	CAT® TDTO Cold Weather SAE 0W-40	CAT® HYDO Advanced 10 SAE 15W-40	CAT® BIO HYDO Advanced ISO46 MultiGrade
		Mobil	Mobil Hydraulic 10W			
D	Coolant (Cooling System)	Shell	Shell Rotella ELC Diluted 50/50	Shell Spirax S4 CX 50		
		Caterpillar	CAT® ELC			
		Mobil	Mobil Permazone 50/50 Diluted Antifreeze & Coolant			
E	Swing Drive, Final Drive (Oil)	Shell	Shell Spirax S4 CX 50			
		Caterpillar	CAT® TDTO SAE 50	CAT® TDTO SYN Cold Weather SAE 0W-20		
		Mobil	Mobil Trans HD 50			

SERVICE RECOMMENDATIONS



Type	Lubricant	Manufacturer	Regular Ambient Temperature: -4°F – 104°F (-20°C – 40°C)	COLD WEATHER: -4°F – 104°F (-20°C – 40°C)	Hot Weather: 5°F – 122°F (-15°C – 50°C)	Biodegradable
F	Main & Auxiliary Winches, Rotary Planetary Gear (Oil)	Shell	Omala S2 G	Omala S4 GX	Omala S4 WE	
		Caterpillar	N/A	N/A		
		Mobil	Mobilgear XMP	Mobilgear SHC	Glygoyle	
G	Main Winch, Auxiliary Winch Brake (Oil)	Shell	Omala S2 G	Omala S4 GX	Omala S4 WE	
		Caterpillar	N/A	N/A		
		Mobil	Mobilgear XMP	Mobilgear SHC	Glygoyle	
H	Rotary Main Case (Oil)	Shell	Shell Omala S4 GX 460	Shell Omala S4 GX 220		
		Caterpillar	N/A			
		Mobil	Mobil SHC Gear 460	Mobil SHC Gear 220		
J	Swing Bearing, Swing Gear, Crawler Slides, Swivel / Rotary & A-frame Bearings, Pulley Bearings, Pins and Bushings (Grease)	Shell	Shell Gadus S3 V460D 2	Shell Gadus S2 V20XKD		
		Caterpillar	CAT® Advanced 3 Moly Grease			
		Mobil	Mobil Grease XHP 462			
K	Kelly Bar, Mast Railways (Grease)	Shell	Shell Gadus S2 V220AC	Shell Gadus S2 V20XKD		
		Caterpillar	CAT® Multipurpose Grease			
		Mobil	Mobil Grease SHC 220			

Lubricating The Machine

The table below specifies the lubrication requirements for LR95. Following these recommendations will prevent excessive wear and reduce the possibility of failure, increasing productivity. Always use oils or lubricants with specifications equivalent to those specified below.

NOTICE

- Callouts on lubrication images are color coded based on their intervals shown in the lubrication table below.
- The following ISO 7000 symbols are used to represent the type of lubricant to be used at each lubrication point:

	Component is lubricated with oil.
	Component is lubricated with grease.
	Component must be cleaned prior to lubrication.

- The lubrication table lists the recommended intervals for standard operation of the drilling rig. It is the responsibility of the operator to evaluate working conditions and adjust intervals as necessary.
- Most lubrication points on the machine are mirrored, make sure that both sides of the drilling rig are lubricated where applicable.

NOTE: An optional automatic lubricating system can be installed. In this case, the items not indicated as being automatically lubricated in the table below still have to be performed manually.

Location #	Description	Check	Change	Grease	Lubricant Specification See “Fluids and Lubricants” on page 10-11	Fittings Quantity	Automatic Lubrication*
1	Main Winch Reducer**	250h	1000h	N/A	Type – F	1	
2	Brake, Main Winch Reducer**	250h	1000h	N/A	Type – G	1	
3	Brake, Auxiliary Winch Reducer**	250h	1000h	N/A	Type – G	1	
4	Auxiliary Winch Reducer**	250h	1000h	N/A	Type – F	1	
5	Bearing, Auxiliary Winch	N/A	N/A	48h	Type – J	1	x
6	Bearing, Main Winch	N/A	N/A	48h	Type – J	1	x
7,8	Bearings, Main Head Mast Sheave	N/A	N/A	48h	Type – J	3	x
9	Bearing, Auxiliary Head Mast Sheave	N/A	N/A	48h	Type – J	1	
10	Bearing, Auxiliary Head Mast	N/A	N/A	48h	Type – J	1	
11	Pin, Kelly Bar Guide	N/A	N/A	48h	Type – J	2	
12	Pin, Kelly Bar Guide	N/A	N/A	48h	Type – J	2	

SERVICE RECOMMENDATIONS

13	Cable Swivel	N/A	N/A	48h	Type – J	2	
14, 15	Tilt Cylinder	N/A	N/A	48h	Type – J	4	x
16 - 20	Pins, Boom Arm	N/A	N/A	48h	Type – J	12	x
21, 22	Pin, Boom Cylinder	N/A	N/A	48h	Type – J	4	x
23	Pin, Mast Tilt	N/A	N/A	48h	Type – J	1	x
24	Mast Guide	N/A	N/A	8h	Type – K	2	
25	Crowd Cylinder	N/A	N/A	1000h	Type – J	1	
26	Bearing, Kelly Bar Guide	N/A	N/A	8h	Type – J	3	
27	Undercarriage	N/A	N/A	48h	Type – K	4	
28	Swing Bearing**	N/A	N/A	500h	Type – J	2	
29	Swing Gear**	N/A	N/A	2000h	Type – J	1	
30	Rotary Head Reducer**	250h	1000h	N/A	Type – H	1	
31	Rotary Head Gearing**	48h	1000h	N/A	Type – H	1	
32	Bearing, Rotary Pinion***	250h	N/A	1000h	See footnote: ***	1	
33, 34	Bearings, Rotary Head	N/A	N/A	8h	Type – J	4	x

* Automatic lubrication by machines equipped with an Automatic Lubrication System.

** Refer to the specific procedure for lubricating instructions and additional information.

*** The Rotary Pinion Bearing is lubricated through the indicated plug, following the procedure:

1. Pour Type H oil into the pinion chamber until the oil covers/soaks the bearing all the way.

2. Once the bearing is submerged, add Shell Gadus S3 V460D 2 (high temperature grease) [or equivalent lubricant] half-way up the pinion shaft.

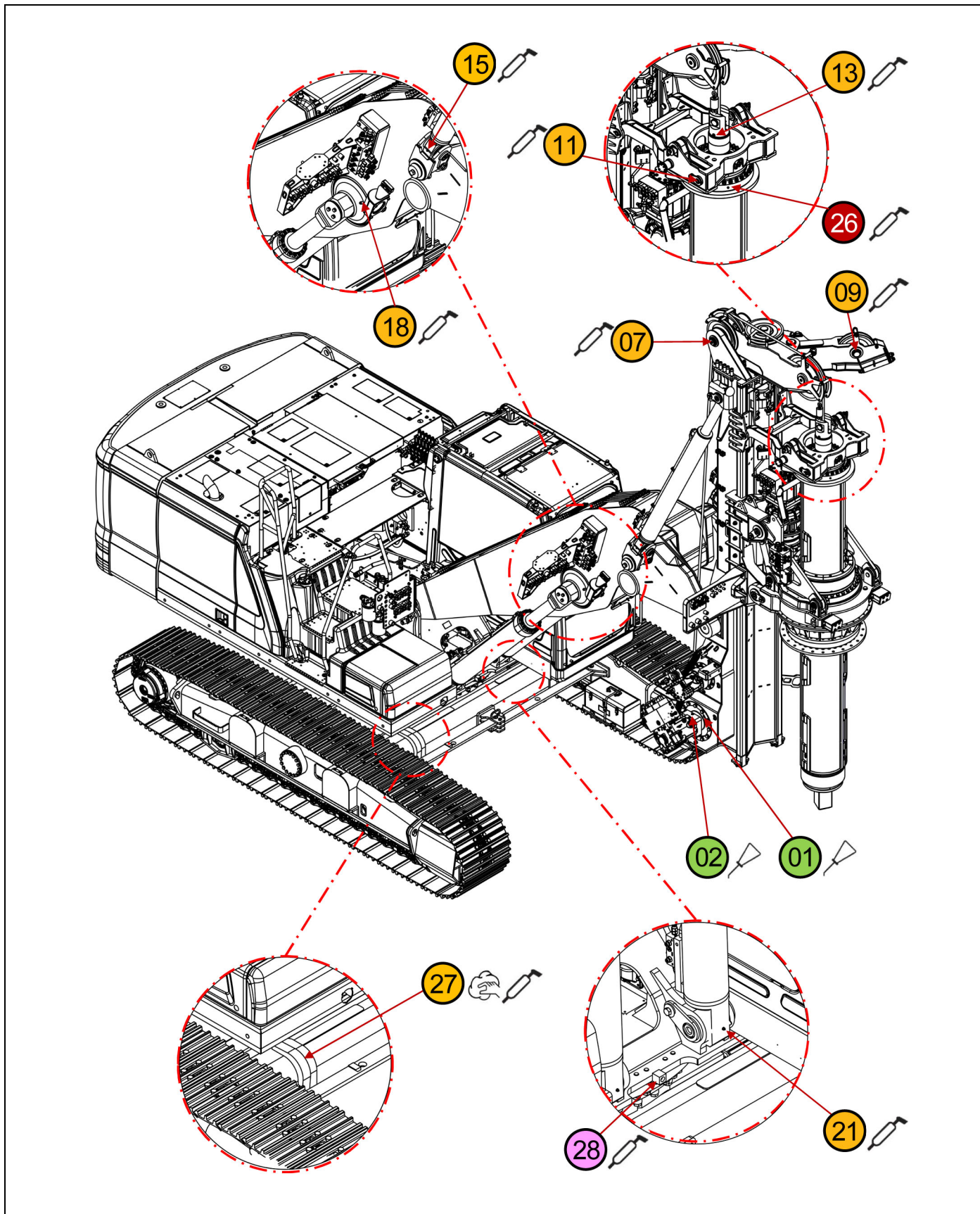

Figure 10-8

0000972

SERVICE RECOMMENDATIONS

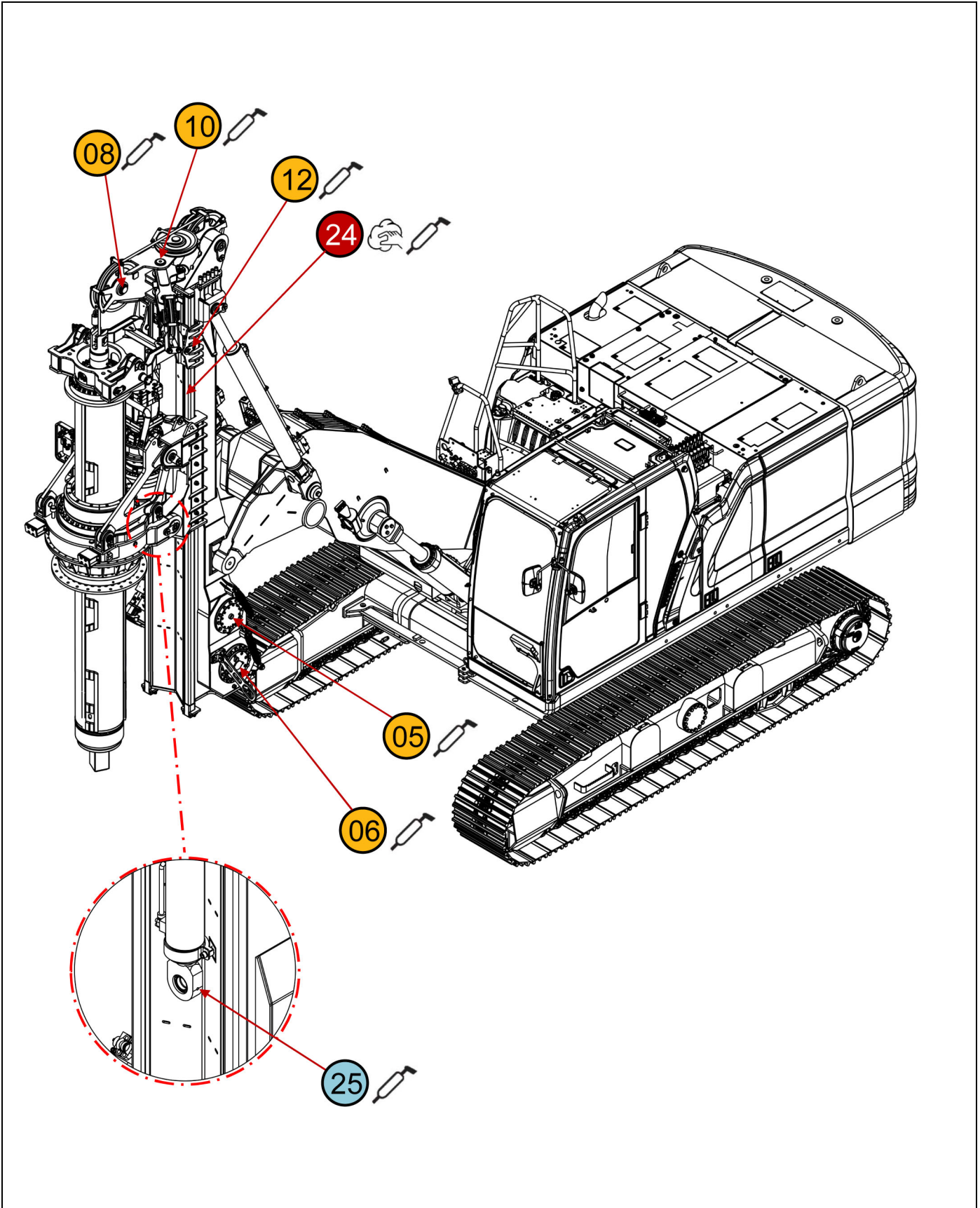

Figure 10-9

0000973

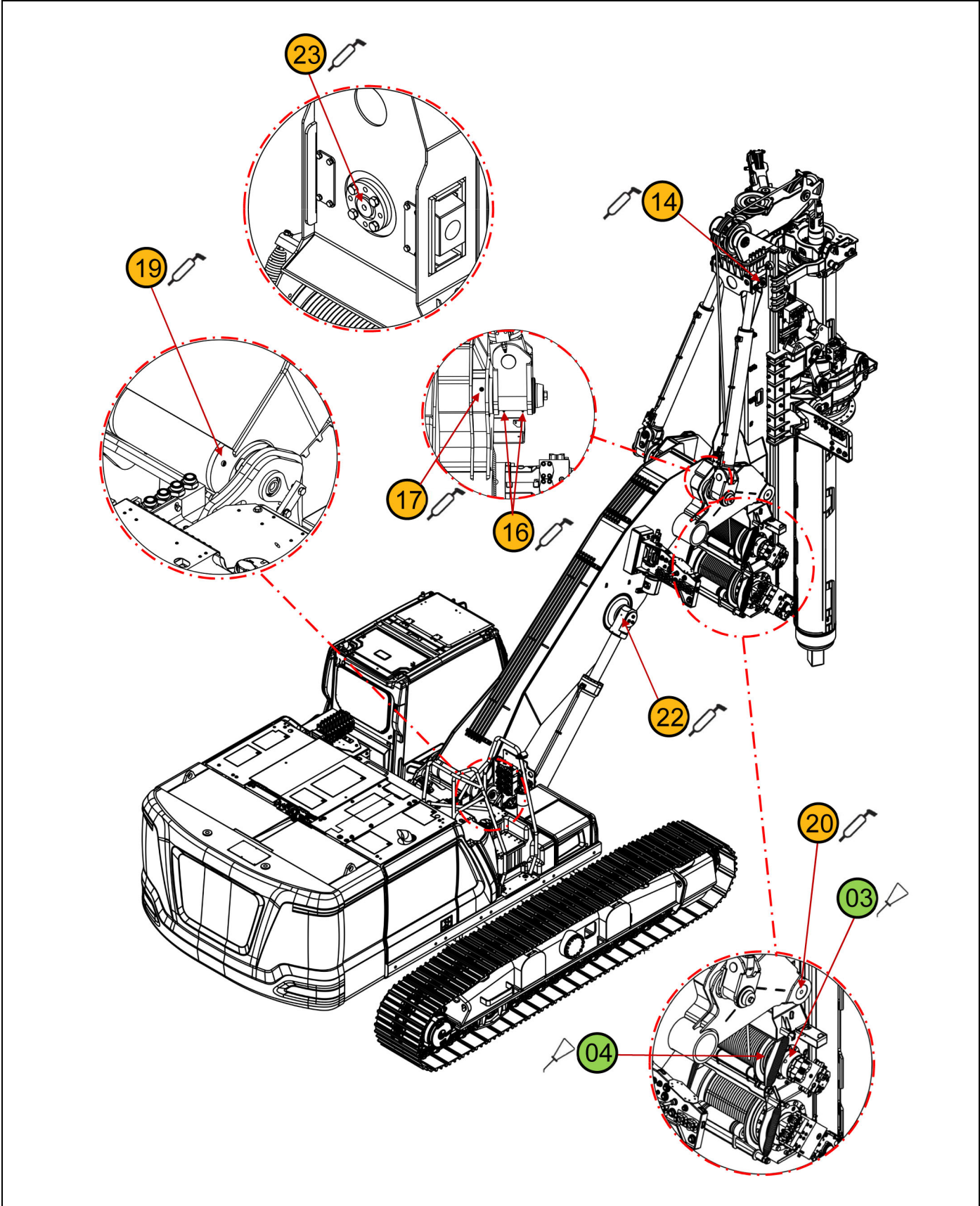
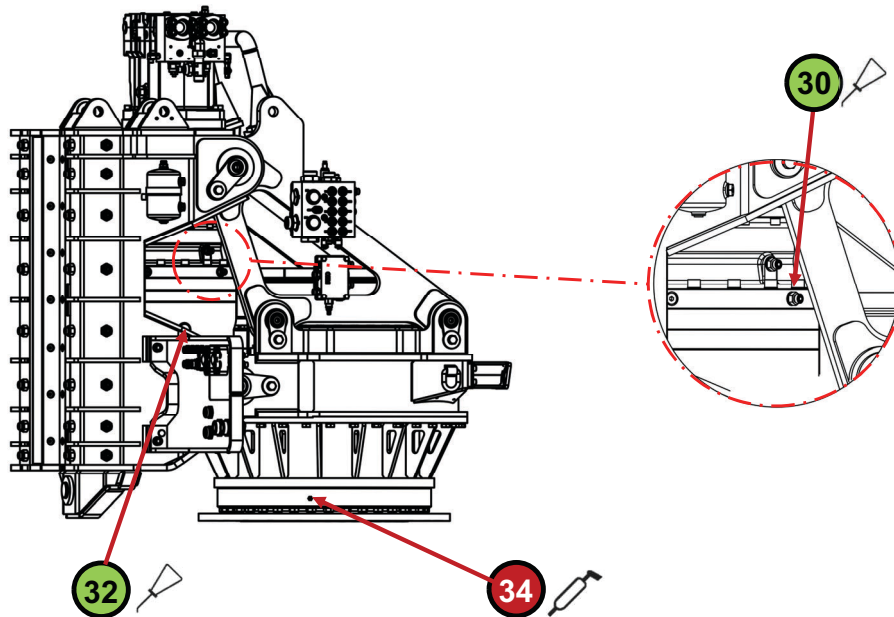
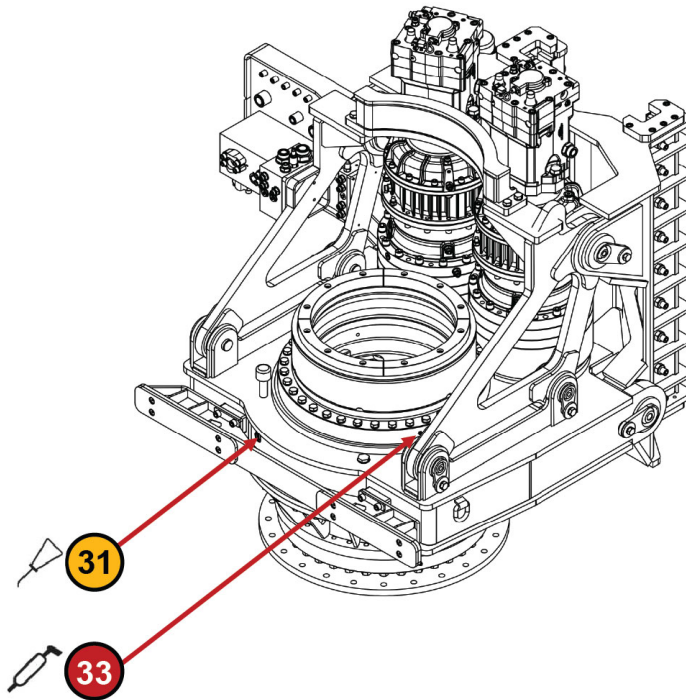

Figure 10-10

0000974

SERVICE RECOMMENDATIONS



0001933 0001934

Wire Rope Maintenance

Inspect the Wire Rope

Wire rope is a consumable component with a limited lifespan. As wire rope ages, it will have some structural damage caused by abrasion and corrosion. The lifespan of the wire rope will vary depending on operating conditions. Wire rope should be replaced whenever damage is found.

Inspect all of the wire rope, but provide extra attention to:

- Attachment points.
- Rope sections that pass through sheaves repeatedly.
- Sections exposed to conditions that may accelerate wear.

Wire rope must be replaced if:

- More than 10 percent of the wires within one strand of wire rope (except for filling steel wire) are open. Filler wires are not considered load bearing.
- Broken wires at the wire rope ends at connecting points. Wire rope may be cut and new rope end fittings attached.
- An abnormal increase in the number of broken wires over a short period of time.
- Rope has distortions such as slack windings, bends, flattening, reduced thickness in spots, protruding strands, or other visible deformations.
- Heavily corroded sections.
- Reduced rope elasticity or increased elongation.

Try to determine if any wire rope defects are caused by a mechanical failure that must be corrected before installing a new wire rope.

Lubricate the Wire Rope

If the wire rope is dirty or has layers of hardened lubricant, it must be cleaned prior to lubrication.

Use a wire rope lubricating oil and grease compatible with the existing lubricants on the wire rope.

It is recommended to lubricate the wire rope with a penetrating rope lubricant followed by a surface protecting grease. Make sure to remove excess grease from the surface to minimize dirt sticking to the grease.

Replace the Winch Wire Rope

1. Place the mast in a horizontal position.
2. Unwind to provide some slack in the cable.
3. Disconnect the wire rope from its live end anchor.
4. Unwind the old wire rope from the winch drum. You will need to enable the override switch to bypass the winch safety limit switch.

⚠ WARNING

Failure to properly anchor the wire rope end can cause the wire rope to pull out and drop the load resulting in death, serious injury, or damage to the machine.

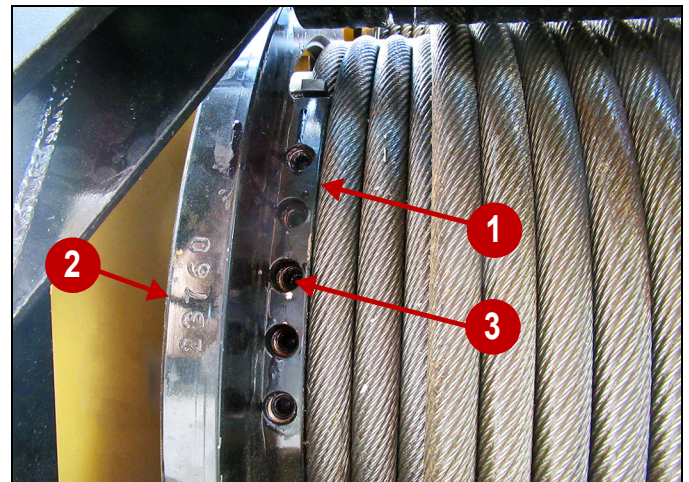

Figure 10-11

- 1) Wire Rope Lock Plate
- 2) Main Winch Drum
- 3) Cap Screw (Qty 5)

NOTE: Main winch drum shown, auxiliary winch drum is similar but has lock plate on the outside of drum.

5. Disconnect the wire rope at the winch drum by removing the lock plate.
6. Secure the new wire rope on to the drum and secure with the lock plate and fasteners.

NOTICE

Keep the wire rope clean, do not allow the wire rope to contact the ground. Do not wind the rope over sharp edges to prevent damage to the wire rope and/or machine.

7. Wind the wire rope on to the drum while applying tension. See "Apply Wire Rope Tension" on page 10-20.

SERVICE RECOMMENDATIONS

8. Enable the winch safety switch and connect the wire rope live end to its anchor point.

Apply Wire Rope Tension

⚠ WARNING

Make sure the new wire rope is pulled directly from the carrier reel. Do not pull the rope off the carrier reel from the side, this will twist the rope and cause distortions when under tension.

To properly wind the new wire rope on the winch, the wire rope must be under tension. If the lower winding layers are too loose, the upper winding layers can press between the lower strands under load resulting in damage to the wire rope.

Some things to consider when tensioning the wire rope during installation:

- Tension the wire rope when winding with at least 2 percent of the wire rope maximum load rating.
- Do not apply tension to a wire rope by squeezing it. For example, squeezing the wire rope between two planks. The wire rope may become permanently deformed.
- Apply tension to the carrier reel holding the new rope, not directly to the rope itself.

After Installation of a New Rope

After the wire rope has been installed, but before being used, make a few small load cycles. The new wire rope should be extended and retracted to seat it properly and allow it to conform to the winch drum.

Main Winch Maintenance

NOTICE

The main winch reducer is oil bath lubricated. The gearbox oil also lubricates the winch brake. The winch must be filled with oil before the winch is operated and the level visually checked for the correct level. When oil is added, the level must be rechecked after a few minutes of operation to make sure that the level is correct.

Check/Add Main Winch Oil

Check Main Winch Reducer/Brake Oil Level

1. Place mast in the vertical operating position (leveled).
2. Place wood blocks on the ground below the work tool.

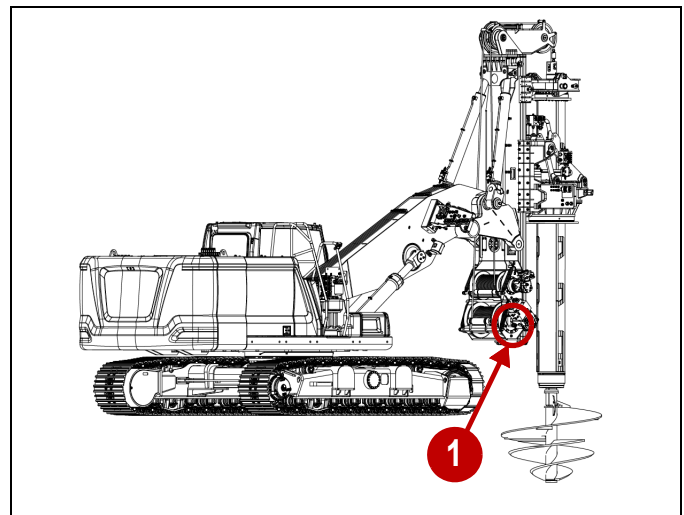

Figure 10-12: Main Winch Oil Plugs

- 1) Main Winch Check/Drain/Fill Plugs
3. The plugs for draining/filling/checking oil are located between the winch drum and the inside of the mast support.

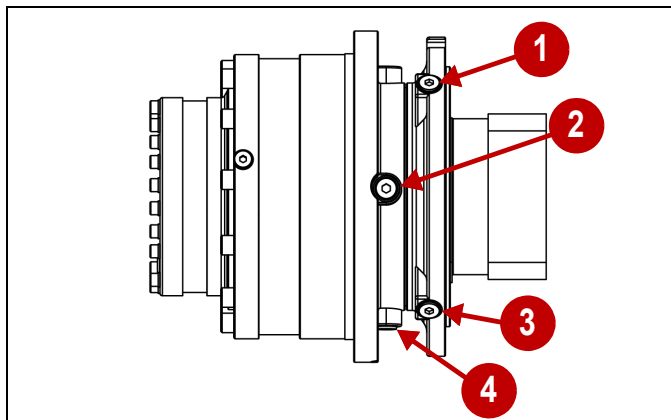

Figure 10-13

0000861

- | | |
|------------------------------------|-----------------------|
| 1) Filler Plug | 3) Brake Drain Plug |
| 2) Oil Level Plug
(Sight Glass) | 4) Reducer Drain Plug |
4. Lower or raise the Kelly bar so that the winch plugs are positioned as follows:
 - Oil sight glass (2) should be at the 9 o'clock position
 - Drain plug (4) at the 6 o'clock position.
 5. Stop the engine. Wait 2 minutes for the oil to settle before checking the level.
 6. Check the oil level through the oil sight glass. Oil should be mid-level on the sight glass.
 7. Add or drain oil as required.

Add Main Winch Reducer/Brake Oil

NOTE: Refer to "Fluids and Lubricants" on page 10-11 for the correct main winch oil.

1. Check the oil level and verify oil is required. See "Check Main Winch Reducer/Brake Oil Level" on page 10-20.
2. Remove the oil filler plug (1).
3. Add oil through the opening. The oil capacity of the main winch is approximately 5.3 qt. (5L).
4. Wait 1 minute for the oil to drain down and recheck the oil level.
5. Add more oil as required until the oil is mid-level on the sight glass (2).
6. Install all plugs, make sure that they are tightened.

Drain and Refill Main Winch Reducer/Brake Oil

1. Operate the winch for about 5 minutes to warm up the oil.
2. Position the machine and winch for checking the oil level. See "Check Main Winch Reducer/Brake Oil Level" on page 10-20.

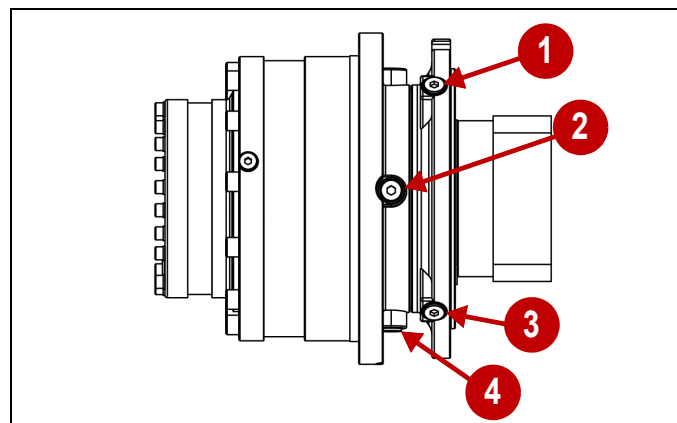

Figure 10-14: Main Winch Sight Glass/Level Plugs

0000861

- | | |
|------------------------------------|-----------------------|
| 1) Filler Plug | 3) Brake Drain Plug |
| 2) Oil Level Plug
(Sight Glass) | 4) Reducer Drain Plug |
3. Remove the filler plug (1).
 4. Remove the reducer drain plug (4) and brake drain plug (3).

NOTE: Drain the oil while the oil is warm for more efficient draining.
 5. Allow the oil to drain.
 6. Clean the plugs and inspect the seals, if damaged, replace the plug or seal.
 7. Check the drained oil for metal chips or particles. If there are any chips or particles, contact the CZM after-sales department.
 8. Wash internals with suitable cleaning liquid.
 9. Install both drain plugs.
 10. Refill with new oil. See "Add Main Winch Reducer/Brake Oil" on page 10-21.

SERVICE RECOMMENDATIONS

Auxiliary Winch Maintenance

NOTICE

The reducer gear oil also lubricates the brake. There is no need to change the brake oil, it is changed when the reducer oil is replaced.

Check/Add Auxiliary Winch Oil

Check Auxiliary Winch Reducer/Brake Oil Level

1. Place mast in the vertical operating position (leveled).
2. Place wood blocks on the ground below the work tool.

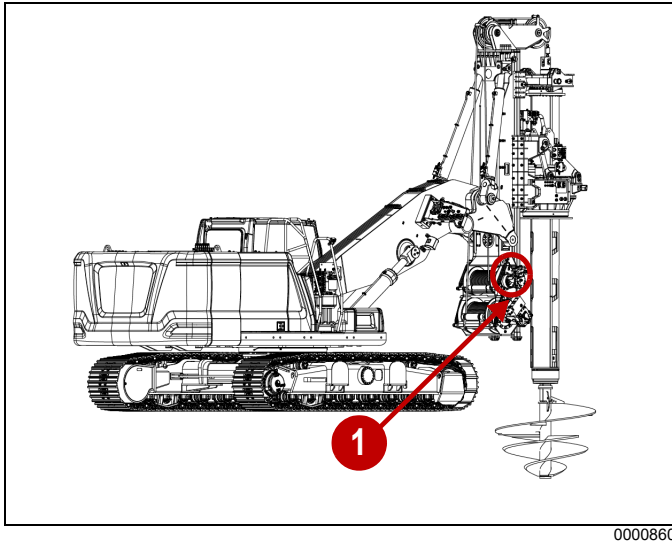

Figure 10-15: Auxiliary Winch Oil Plugs

- 1) Auxiliary Winch Check/Drain/Fill Plugs
3. The plugs for draining/filling/checking auxiliary winch oil are located between the auxiliary winch drum and the inside of the mast support.

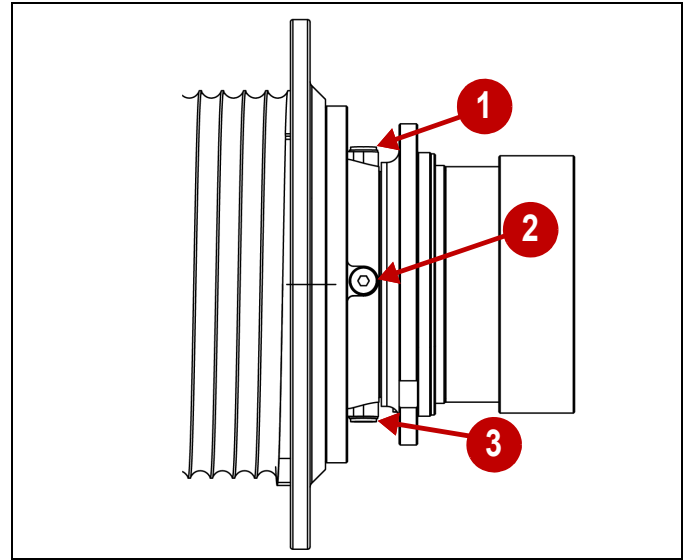

Figure 10-16: Auxiliary Winch Sight Glass/Level Plugs

- 1) Filler Plug
- 2) Oil Level Plug (Sight Glass)
- 3) Brake Drain Plug
4. Rotate the auxiliary winch until the winch plugs are positioned as follows:
 - Oil sight glass (2) should be at the 9 o'clock position.
 - Drain plug (3) at the 6 o'clock position.
 - Filler plug (1) at the 12 o'clock position.
5. Stop the engine. Wait 2 minutes for the oil to settle before checking the level.
6. Check the oil level through the oil sight glass. Oil should be mid-level on the sight glass.
7. Add or drain oil as required.

Add Auxiliary Winch Reducer/Brake Oil

NOTE: Refer to "Fluids and Lubricants" on page 10-11 for the correct main winch oil.

1. Check the oil level and verify oil is required. See "Check Auxiliary Winch Reducer/Brake Oil Level" on page 10-22.
2. Remove the oil filler plug (1).
3. Add oil through the opening. The oil capacity of the auxiliary winch is approximately 2.1 qt. (2L).
4. Wait 1 minute for the oil to drain down and recheck the oil level.
5. Add more oil as required until the oil is mid-level on the sight glass (2).
6. Install all plugs, make sure that they are tightened.

Drain and Refill Auxiliary Winch Reducer/Brake Oil

1. Operate the auxiliary winch for about 5 minutes to warm up the oil.
2. Position the machine and winch for checking the oil level. See "Check Main Winch Reducer/Brake Oil Level" on page 10-20.

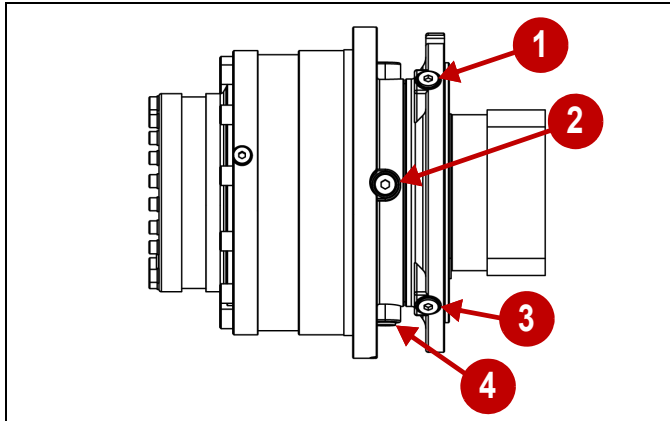

0000861

Figure 10-17: Main Winch Sight Glass/Level Plugs

- | | |
|---------------------------------|-----------------------|
| 1) Filler Plug | 3) Brake Drain Plug |
| 2) Oil Level Plug (Sight Glass) | 4) Reducer Drain Plug |
3. Remove the filler plug (1).
 4. Remove the reducer drain plug (4) and brake drain plug (3).
- NOTE:** Drain the oil while the oil is warm for more efficient draining.
5. Allow the oil to drain.
 6. Clean the plugs and inspect the seals, if damaged, replace the plug or seal.
 7. Check the drained oil for metal chips or particles. If there are any chips or particles, contact the CZM after-sales department.
 8. Wash internals with suitable cleaning liquid.
 9. Install both drain plugs.
 10. Refill with new oil. See "Add Auxiliary Winch Reducer/Brake Oil" on page 10-22.

Rotary Drive Maintenance Check/Add Rotary Drive Reducer Oil

Check Rotary Head Reducer Oil Level

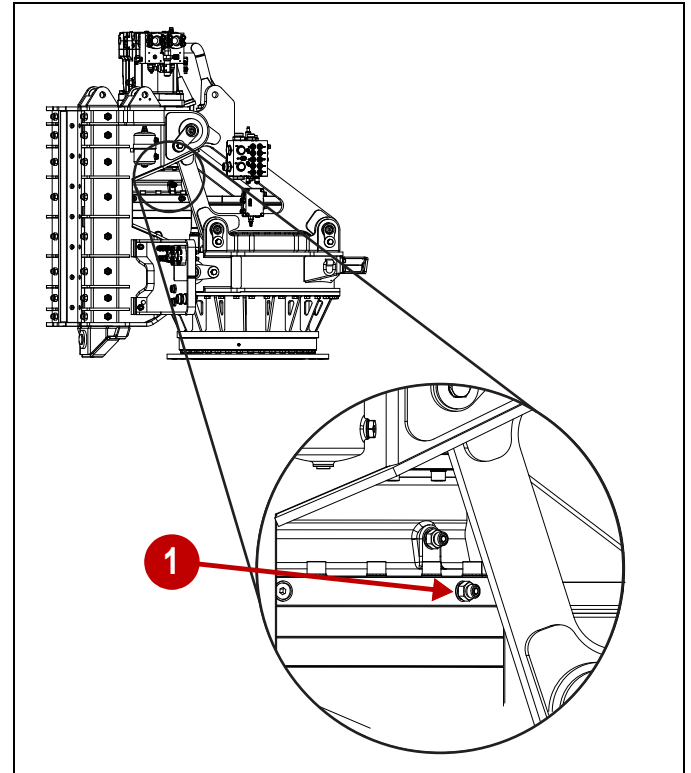

0000909

Figure 10-18

- 1) Drain/Fill/Level Plug
1. Place the mast in the vertical operating position (leveled).
 2. Position the rotary all the way to the bottom of the mast.
 3. Remove any tooling attached to the kelly bar.
 4. Wait 2 minutes for the oil to settle before checking the level.
 5. Prepare the machine for service. See "Prepare the Machine for Maintenance*" on page 10-5.
 6. Remove the rotary head drain/fill/level plug (1). The oil level should be at the bottom of the plug hole.
 7. If the oil level is low, add oil. See "Add Rotary Head Reducer Oil".
 8. Install and tighten the drain/fill/level plug.

SERVICE RECOMMENDATIONS

Add Rotary Head Reducer Oil

NOTE: Refer to “Fluids and Lubricants” on page 10-11 for the correct reducer oil.

1. Place the mast in the vertical operating position (leveled).
2. Position the rotary all the way to the bottom of the mast.
3. Remove any tooling attached to the kelly bar.
4. Prepare the machine for service. See “Prepare the Machine for Maintenance*” on page 10-5.

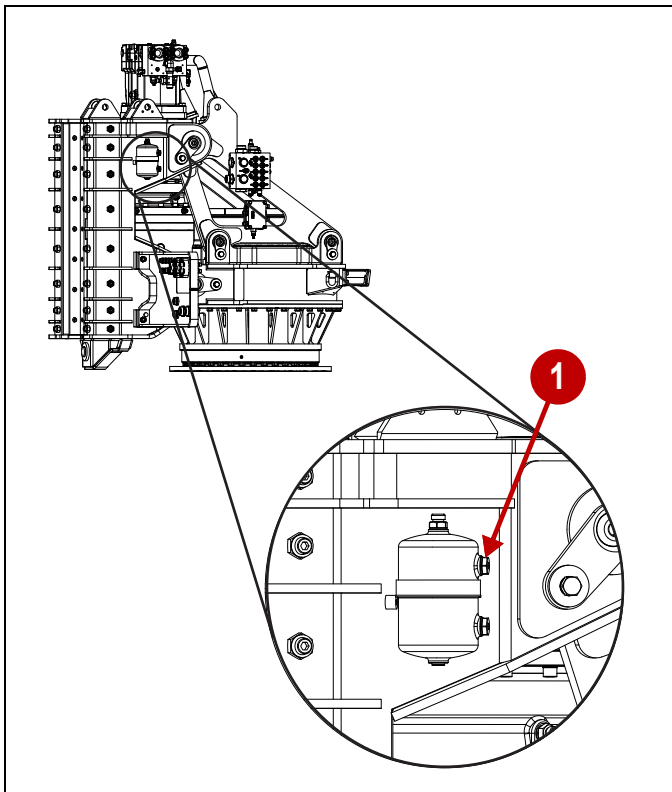

0000910

1) Top Overflow Plug

5. Remove the top overflow plug (1).

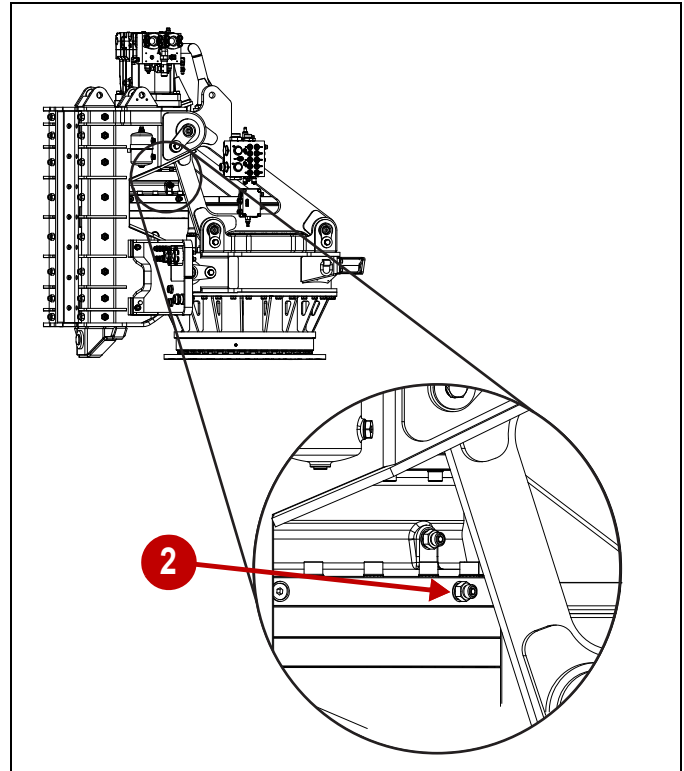

0000909

Figure 10-19

2) Drain/Fill/Level Plug

6. Remove the rotary head drain/fill/level plug (2).
7. Add oil through the drain/fill/level plug (2) hole until the level is at the bottom of the hole.
8. Clean the plugs and inspect the seals. If damaged, replace the plug or seal.
9. Install and tighten all removed plugs.

Drain and Refill Rotary Head Reducer Oil

NOTE: Refer to “Fluids and Lubricants” on page 10-11 for the correct reducer oil and volume required.

NOTICE

Care must be taken to ensure that fluids are contained during performance of inspection, maintenance, testing, adjusting, and repair of the machine. Be prepared to collect the fluid with suitable containers before opening any compartment or disassembling any component containing fluids.

Contact the CZM After Sales Department for tools and supplies suitable to collect and contain fluids on CZM products.

Dispose of all fluids according to local regulations and mandates.

1. Operate the rotary without any load for about 5 minutes to warm up the oil.
2. Place rotary all the way to the bottom of the mast.
3. Remove any tooling attached to the kelly bar.
4. Place mast in the transport (horizontal) position (1).
5. Prepare the machine for service. See “Prepare the Machine for Maintenance*” on page 10-5.

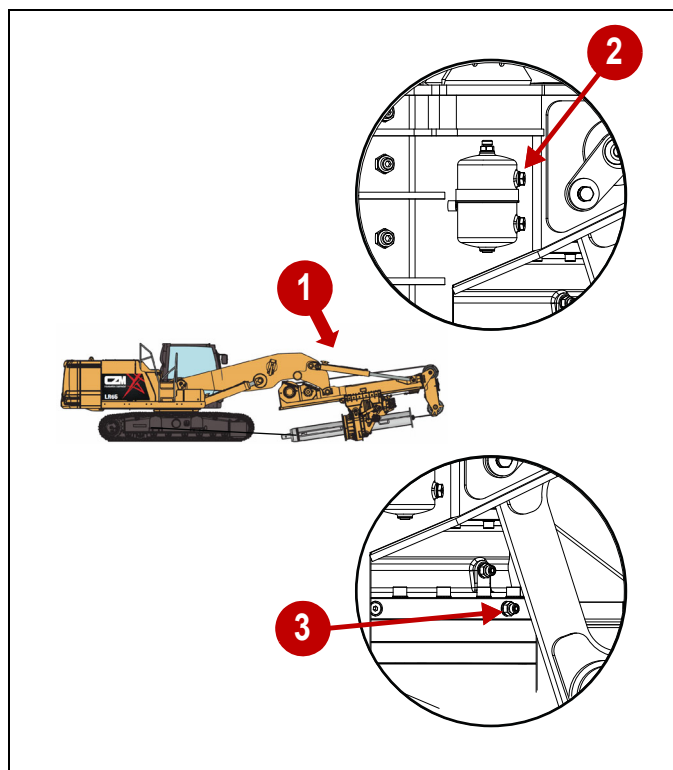

Figure 10-20

0000911

- | | |
|-----------------------|--------------------------|
| 1) Transport Position | 3) Drain/Fill/Level Plug |
| 2) Top Overflow Plug | |
6. Remove the top overflow plug (2).
 7. Remove the reducer drain/fill/level plug (2) and most of the old oil will flow out.
 8. Using a flexible hose that fits in the drain hole, pump the remaining oil out (make sure the hose being used is clean and no debris is left inside).
 9. Clean the plugs and inspect the seals, if damaged, replace the plug or seal.
 10. Check the drained oil for metal chips or for particles. If there are any chips or particles, contact CZM after-sales support.
 11. Place the mast back in the vertical operating position.
 12. Add new oil through the reducer drain/fill/level plug hole (2). When oil is at the bottom of the hole, it is full.
 13. Install and tighten all removed plugs.

SERVICE RECOMMENDATIONS

Check/Add Rotary Gearbox Oil

Check Rotary Gearbox Oil

1. Place mast in the vertical operating position (leveled).
2. Position rotary all the way to the bottom of the mast.
3. Lower the auger to the ground.
4. Make sure there is no suspended load.
5. Wait 2 minutes for the oil to drain down before checking the level.
6. Prepare the machine for service. See "Prepare the Machine for Maintenance*" on page 10-5.

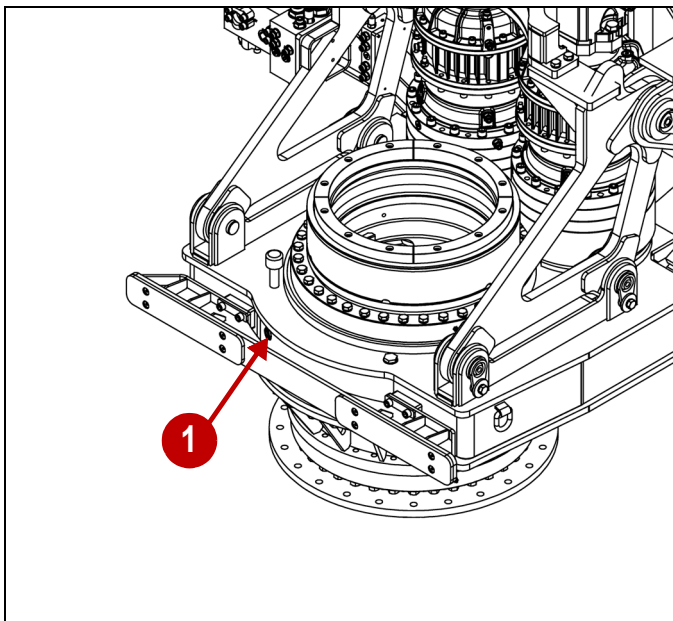

Figure 10-21: Oil Level Sight Glass

- 1) Oil Level Sight Glass

7. Check the oil level at the sight glass (1). The oil level should be in the middle of the sight glass. If there is a level plug instead of a sight glass, remove it, the oil level should be at the bottom of plug hole.
8. Add oil if required. See "Add Rotary Gearbox Oil".

Add Rotary Gearbox Oil

NOTE: Refer to "Fluids and Lubricants" on page 10-6 for the correct gearbox oil.

1. Operate the function without any load for about 5 minutes to warm up the oil
2. Place mast in the vertical operating position (leveled)
3. Place rotary all the way to the bottom of the mast
4. Lower the auger to the ground.
5. Make sure there is no suspended load.
6. Prepare the machine for service. See "Prepare the Machine for Maintenance*" on page 10-5.

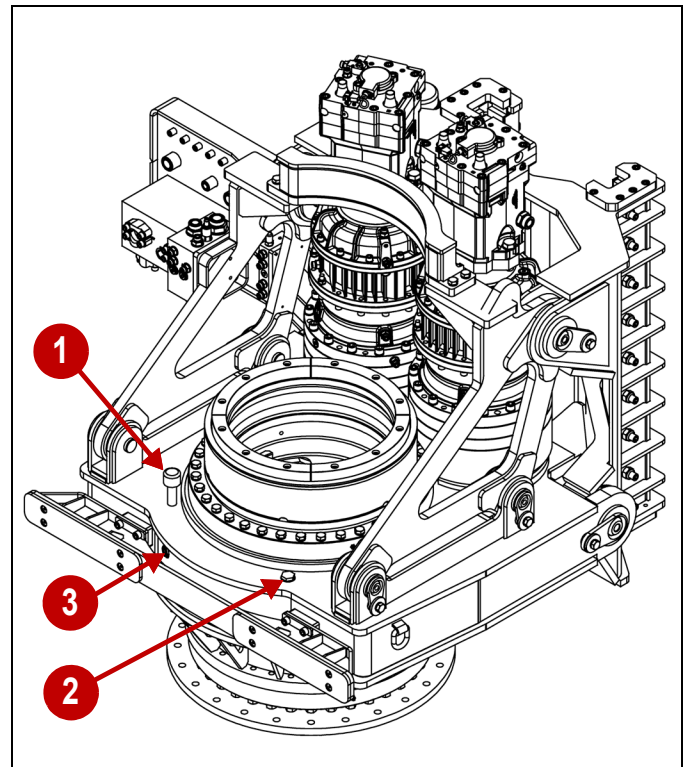

- 1) Breather
- 2) Filler Plug
- 3) Sight Glass

7. Remove the breather plug (1).
8. Remove the rotary gearbox filler plug (2).
9. Add oil through the filler plug hole until the level is at the bottom of the hole or half-way level on the sight glass (3).
10. Clean the plugs and inspect the seals, if damaged, replace the plug or seal.
11. Install and tighten all removed plugs.

Drain and Refill Rotary Gearbox Oil

NOTE: Refer to “Fluids and Lubricants” on page 10-11 for the correct gearbox oil and required volume.

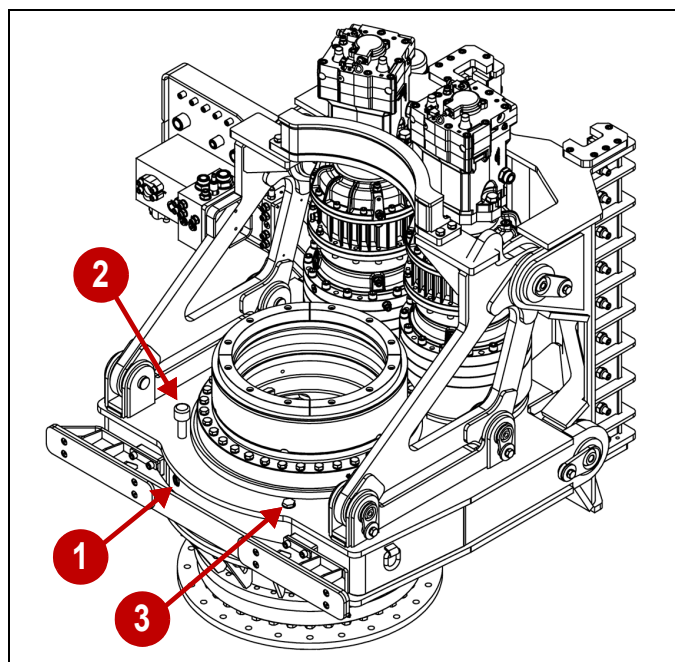

Figure 10-22: Rotary Head Gearbox

- | | |
|------------------|----------------|
| 1) Sight Glass | 3) Filler Plug |
| 2) Breather Plug | |

NOTICE

Care must be taken to ensure that fluids are contained during performance of inspection, maintenance, testing, adjusting, and repair of the machine. Be prepared to collect the fluid with suitable containers before opening any compartment or disassembling any component containing fluids.

Contact the CZM After Sales Department for tools and supplies suitable to collect and contain fluids on CZM products.

Dispose of all fluids according to local regulations and mandates.

1. Operate the rotary without any load for about 5 minutes to warm up the oil.
2. Place the mast in a vertical operating position (leveled).
3. Position the rotary all the way to the bottom of the mast.
4. Lower the auger to the ground.

5. Make sure there is no suspended load.
6. Prepare the machine for service. See “Prepare the Machine for Maintenance*” on page 10-5.
7. Remove the breather plug (2).
8. Remove drain plugs (4) and (5) to drain the old oil.

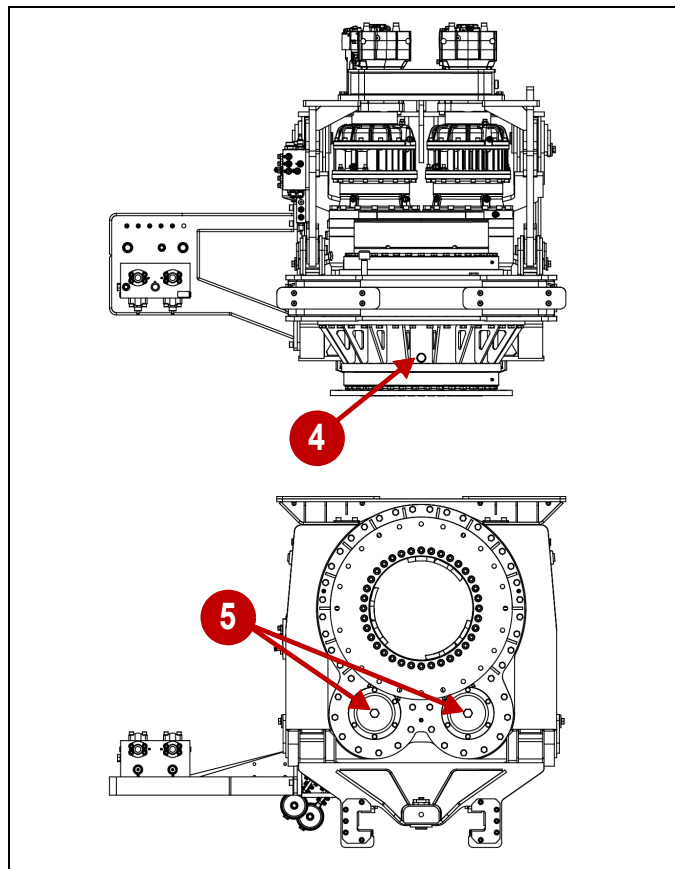

Figure 10-23: Rotary Gearbox Drain Plugs

- | | |
|-----------------------|-----------------------|
| 4) Gearbox Drain Plug | 5) Reducer Drain Plug |
|-----------------------|-----------------------|
9. Check the drained oil for metal chips or for particles. If there are any chips or particles, contact CZM after-sales support.
 10. Clean the plugs and inspect the seals, if damaged, replace the plug or seal. Install the drain plugs (4) and (5).
 11. Remove the top filling plug (3) and add the new oil through it.
 12. Stop filling when the oil level is at the middle of the sight glass (1). If there is a level plug instead of a sight glass, remove it and add oil until the level is at the bottom of plug hole.
 13. Wait 1 minute for the oil to drain down and recheck, the oil level. Add more oil if needed.
 14. Install and tighten all removed plugs.

SERVICE RECOMMENDATIONS

Kelly Bar Installation And Removal

The installation and removal of the kelly bar requires the use of an external crane.

Kelly Bar Removal

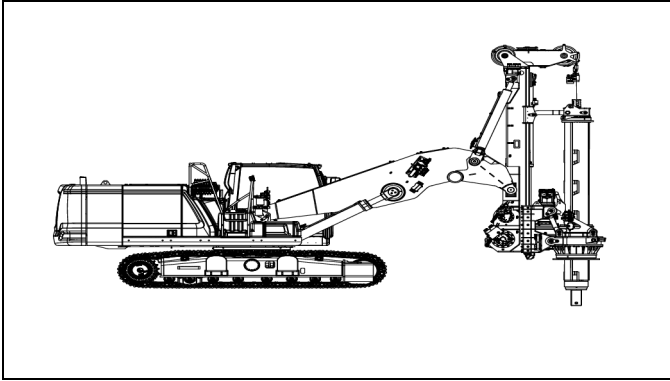

Figure 10-24

1. Remove the work tool.
2. Place the mast in the vertical operating position (leveled) and lower the kelly bar to the ground.
3. Position the rotary head all the way to the bottom of the mast.
4. Disconnect the main winch cable from the kelly bar swivel and raise the mast head.
5. Attach the external crane lifting device to the kelly bar swivel.

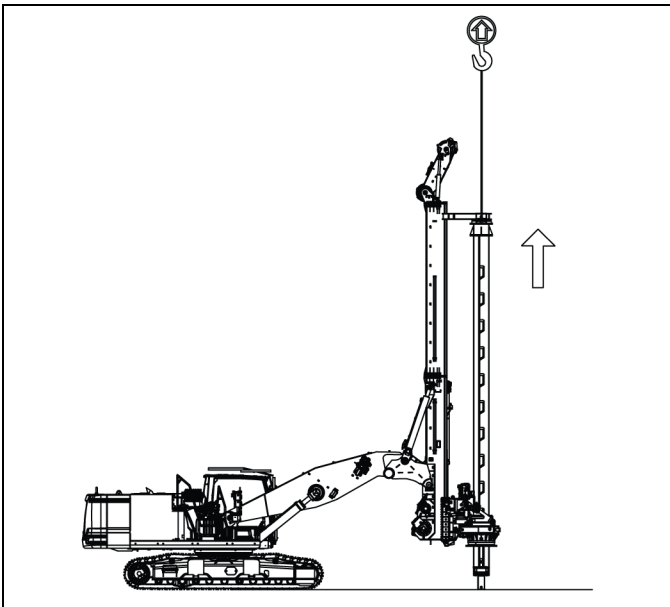

Figure 10-25: External Crane to Kelly Bar Swivel

6. Using the external crane, raise the kelly bar out of the rotary head. Make sure the kelly bar is not interlocked with the rotary.
7. With the kelly bar/A-frame clear of the drilling rig, lower the kelly bar to the ground.

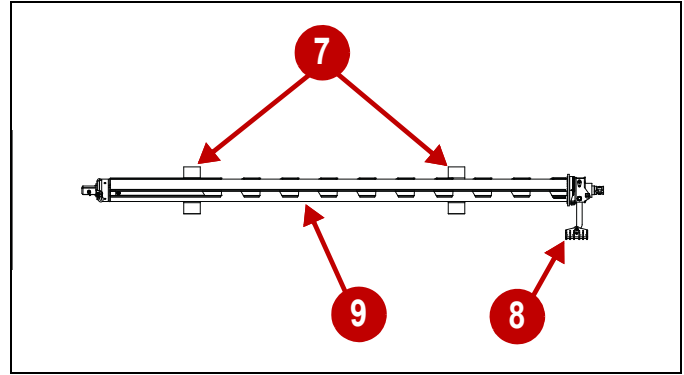

Figure 10-26

- 6) Wood Block 7) A-frame 8) Kelly Bar

NOTE: Wood support blocks for the kelly bar should have a notch cut into them to prevent the kelly bar from rolling off of them.

8. Place wood support blocks (7) under the kelly bar (9) as it is lowered. Move the machine away from the kelly bar as it is lowered so it clears the machine.
9. After the kelly bar is lowered and fully supported on wood blocks, disconnect the external crane lifting device from the swivel.

Remove the A-frame (8). See "A-frame Removal" on page 10-34.

Kelly Bar Installation

1. Start with the kelly bar laying down horizontally on wood support blocks and the A-frame attached, see "A-frame Installation" on page 10-35.

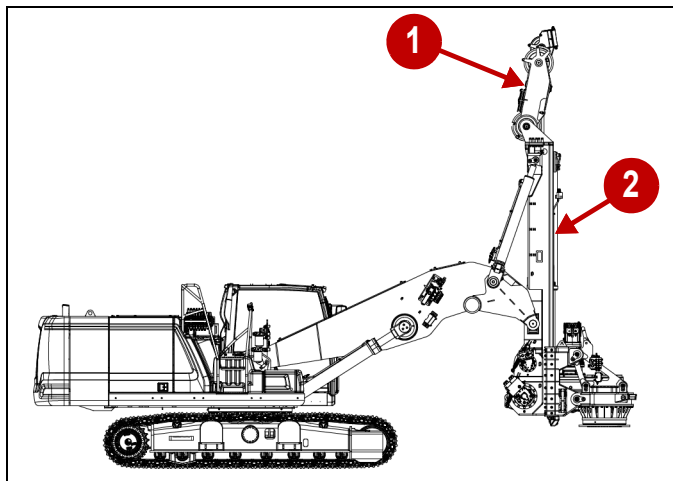

Figure 10-27

- 1) Mast Head 2) Mast
2. With the mast (2) in the vertical position, and the mast head (1) lifted, position the drilling rig in front of the top of the kelly bar.
3. Lower the rotary head to lowest position on the mast.
4. Install the swivel to the kelly bar. See "Swivel Installation" on page 10-36 for more information.
5. Install the A-frame to the kelly bar. See "A-frame Installation" on page 10-35 for more information.

NOTICE

Make sure that the swivel is facing up when attaching it to the external crane. This position will allow the crane cable to freely move up/down. Failure to follow this notice could cause damage to the swivel, and/or the kelly bar eye will bend.

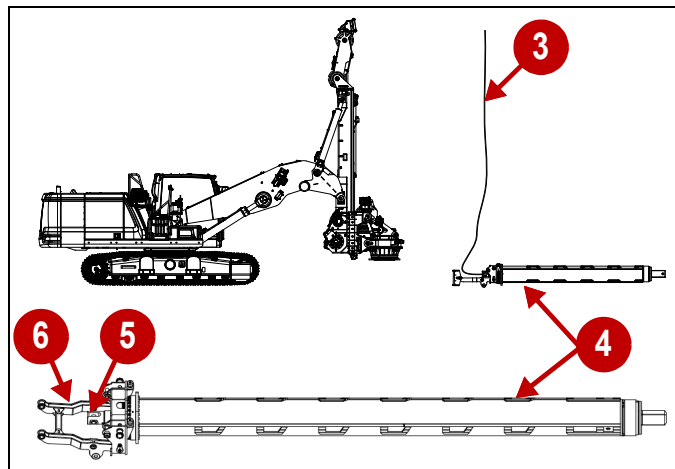

Figure 10-28: Attach Crane to Swivel

- 3) Wire Rope - Crane 5) Swivel
- 4) Kelly Bar 6) A-frame
6. Attach an appropriate lifting device from a external crane wire rope (3) to the swivel (5) at the top of the kelly bar.
7. Using the external crane, slightly raise the kelly bar/A-frame off the ground.
8. Continue to raise the kelly bar/A-frame until it can be aligned with the rotary head.

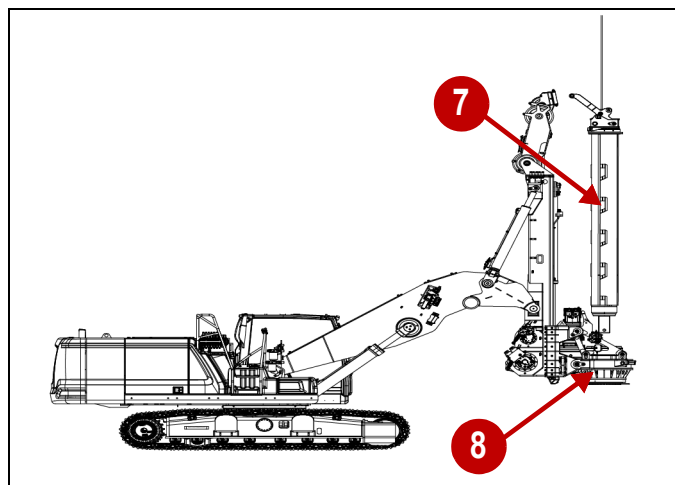

Figure 10-29: Align Kelly Bar and Rotary Head

- 7) Kelly Bar 8) Rotary Head
9. Align the kelly bar with the rotary head.
10. Carefully lower the kelly bar through the rotary head. Make sure the A-frame guides correctly slide down the mast rails.
11. Continue lowering the kelly bar to the ground to support its weight, and raise the rotary head.

SERVICE RECOMMENDATIONS

12. Disconnect the external crane from the kelly bar.
13. Lower the mast head, and attach the main winch and attach the main winch cable

The completed final assembly is shown below:

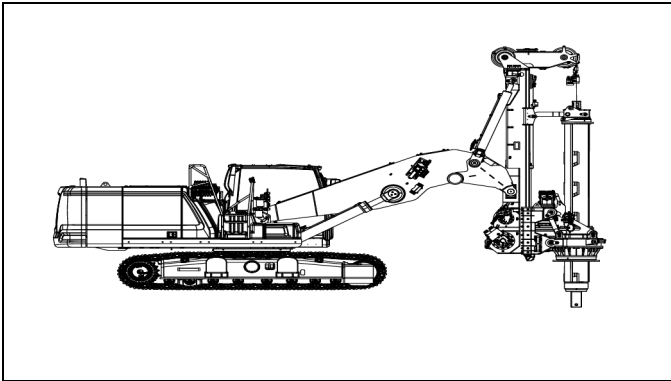

Figure 10-30

0000840

Rotary Head Remove And Install Rotary Head Removal

1. Remove the kelly bar from the machine. See “Kelly Bar Installation And Removal” on page 10-28.
2. Make sure the mast is in the vertical operating position (leveled).
3. Support the rotary head for removal, use a forklift, or if one is not available, lower the rotary onto wood blocks for support:

Support the Rotary Head With a Forklift

If a forklift is available, use it to support the rotary head by lowering the rotary head onto the forks.

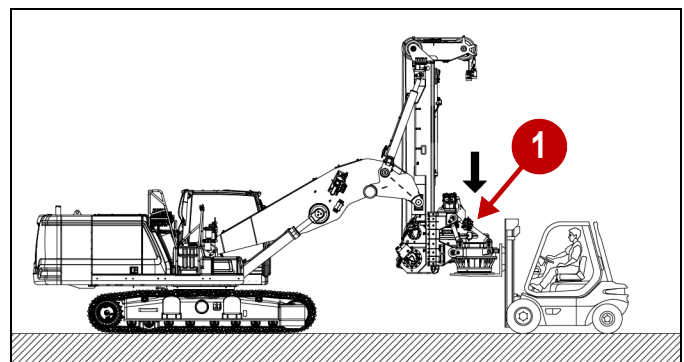

Figure 10-31

0000846

- 1) Rotary Head

Support the Rotary Head On Wood Blocks

If a forklift is not available, lower the rotary head onto wood support blocks.

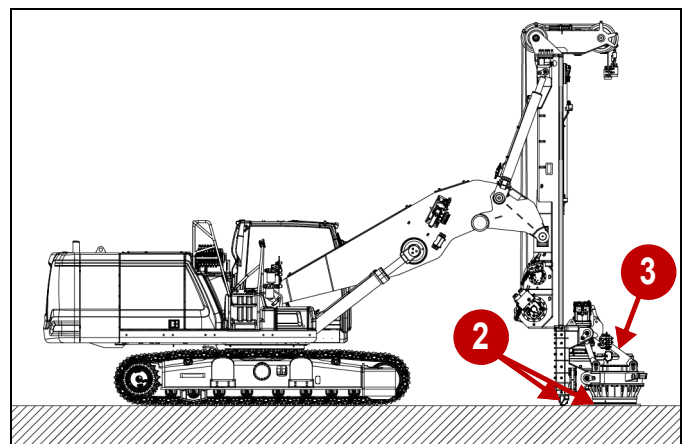
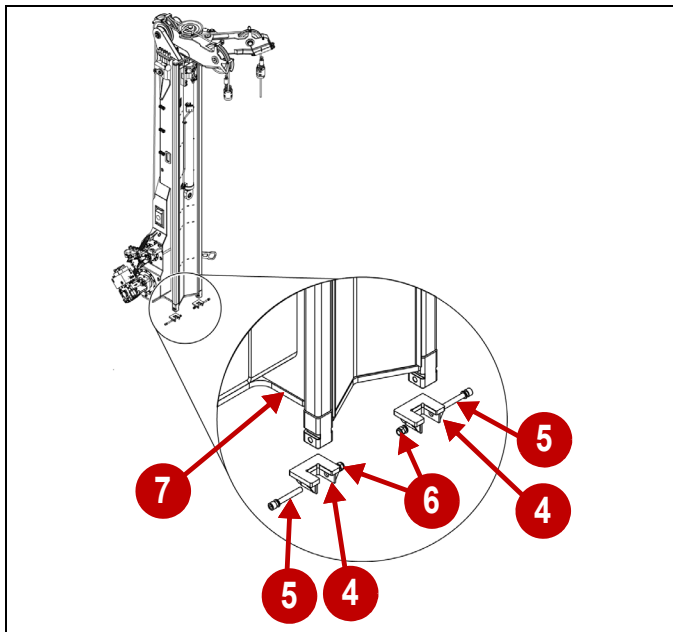

Figure 10-32

0000852

- 2) Wood Blocks
- 3) Rotary Head



0000848

Figure 10-33: Mast Locks

- 4) Mast Lock
- 5) Mast Bolts
- 6) Mast Lock Nuts
- 7) Foot Mast

4. Remove the mast locks (4) from both sides of the foot mast.

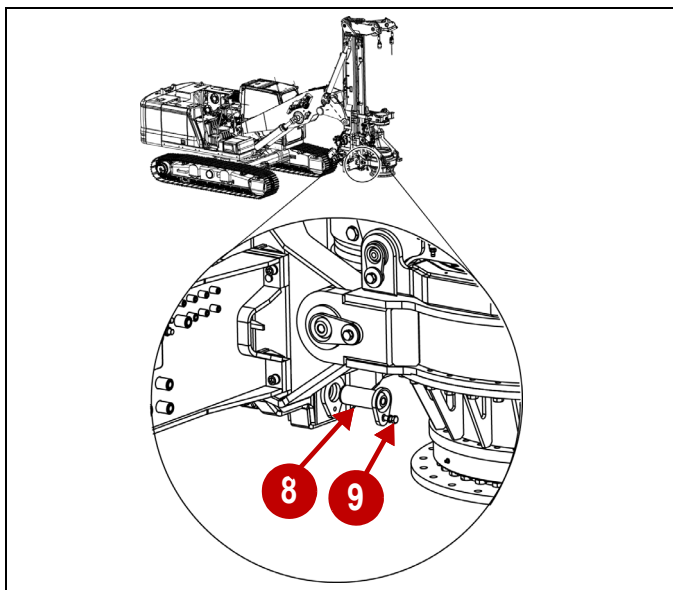

0000851

Figure 10-34: Crowd Cylinder Pin

- 8) Crowd cylinder rod pin
 - 9) Lock bolt
5. Remove the lock bolt (9) and crowd cylinder rod pin (8) to disconnect the crowd cylinder from the rotary. If necessary, slightly move the crowd cylinder to facilitate the removal of the pin.

6. Separate the rotary head from the mast:
- If using a forklift, lower the rotary until the mast is above the rotary.
 - If the rotary head is supported on wood blocks on the ground, slowly raise the mast (10) and at the same time move the machine forward (12) until the mast is above the rotary. Make sure the mast auto level function (11) is activated throughout this step so the mast remains vertical.

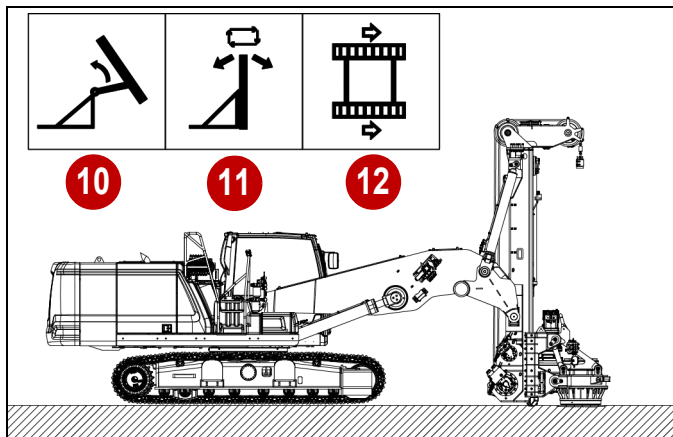

0000850

Figure 10-35

NOTE: If you are replacing the rotary sled wear pads, you can do this without completing the rotary head removal procedures. See "Wear Pad Removal" on page 10-36.

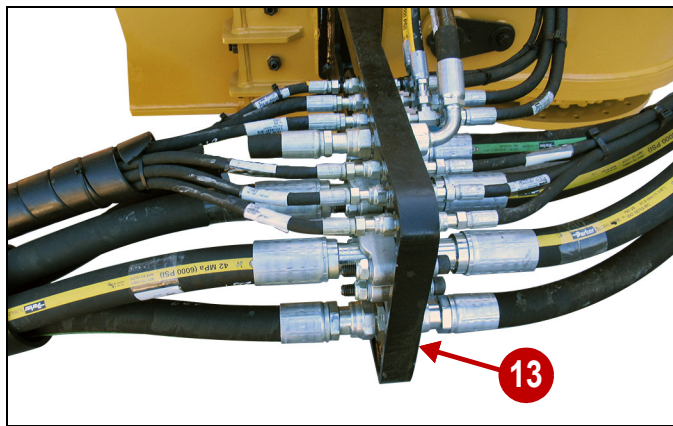

0000366

Figure 10-36: Typical Sled Hydraulic Manifold

- 7. Tag and disconnect the hydraulic lines to the rotary sled manifold (13). Cap and plug all open hydraulic lines and fittings.
- 8. Disconnect electrical connectors to the rotary head.

SERVICE RECOMMENDATIONS

Rotary Head Installation

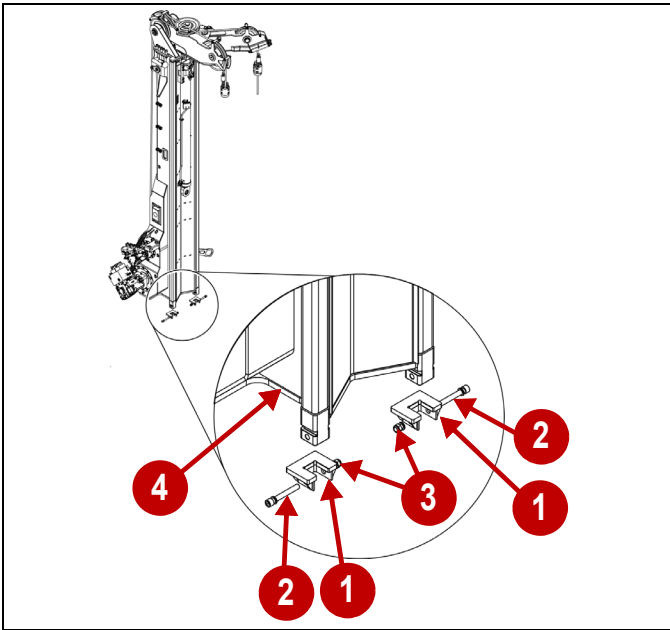

0000848

Figure 10-37: Mast Locks

- | | |
|---------------|------------------|
| 1) Mast Lock | 3) Mast Lock Nut |
| 2) Mast Bolts | 4) Foot Mast |
1. Remove the mast lock assemblies from both sides of the foot mast.

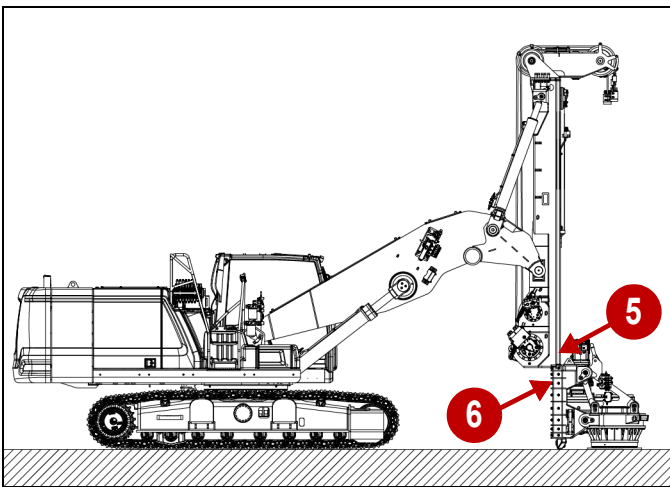

0000847

Figure 10-38: Mast to Rotary Head Alignment

- | | |
|-------------------|---------------------|
| 5) Foot Mast Rail | 6) Rotary Head Sled |
|-------------------|---------------------|
1. Position the machine so that the foot mast rails (5) are above and aligned between the wear pads on the rotary head sled (6). Use wood blocking to support the rotary head off the ground.

2. Slide the rotary onto the mast rails by following one of the procedures:

Install the Rotary Head Using a Forklift

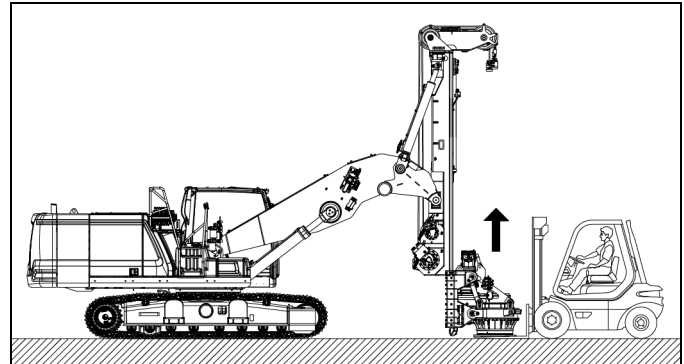

0000845

Figure 10-39

Use a forklift to raise the rotary and slide it up the rails of the mast. Stop after the bottom of the foot mast rail is below the rotary sled. Forklift must support the rotary until it is properly secured on the crowd cylinder, and mast locks are installed.

Install the Rotary Head Without a Forklift

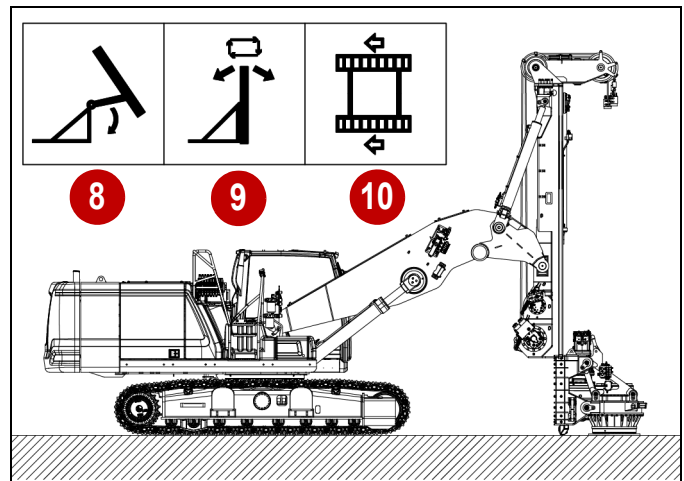

0000849

Figure 10-40

Slowly lower the mast (8) while moving the machine backward (10), the mast auto level function (9) must remain activated so the mast remains vertical throughout procedure. Stop lowering the mast when the bottom of the foot mast rail is below the rotary sled.

3. Install the mast locks (1) and secure with mast bolts (2) and lock nuts (3).

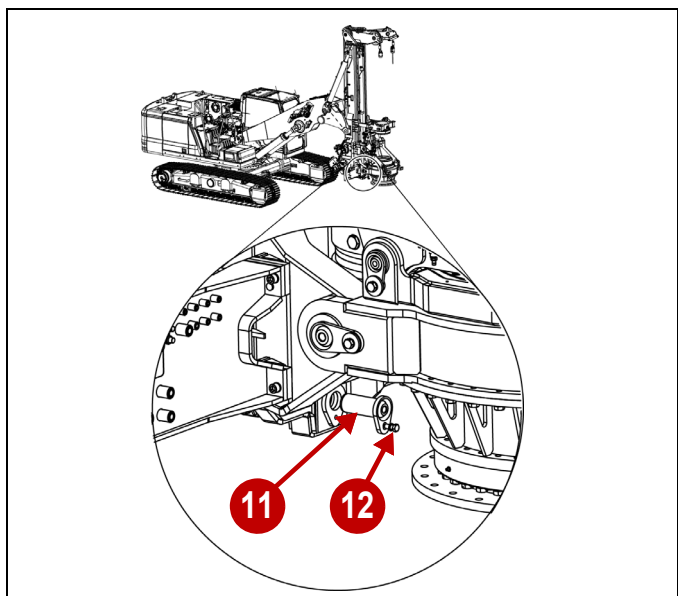

0000851

Figure 10-41: Crowd Cylinder Pin

11) Crowd cylinder rod pin 12) Lock bolt

4. Align the crowd cylinder rod end with the rotary head and install the rod pin (11) to secure the crowd cylinder to the rotary sled. If necessary, slightly move the crowd cylinder to facilitate the installation of the pin.

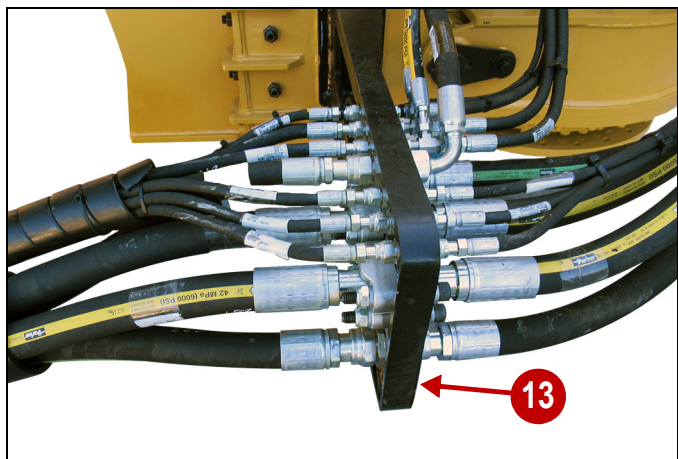

0000366

Figure 10-42: Typical Sled Hydraulic Manifold

13) Rotary sled manifold

5. Connect the hydraulic lines to the rotary sled manifold (13). Use tags made during disassembly for identification of connections.
6. Connect electrical connectors.
7. Install the kelly bar on the machine. See “Kelly Bar Installation And Removal” on page 10-28.

SERVICE RECOMMENDATIONS

A-frame Remove And Install

A-frame Removal

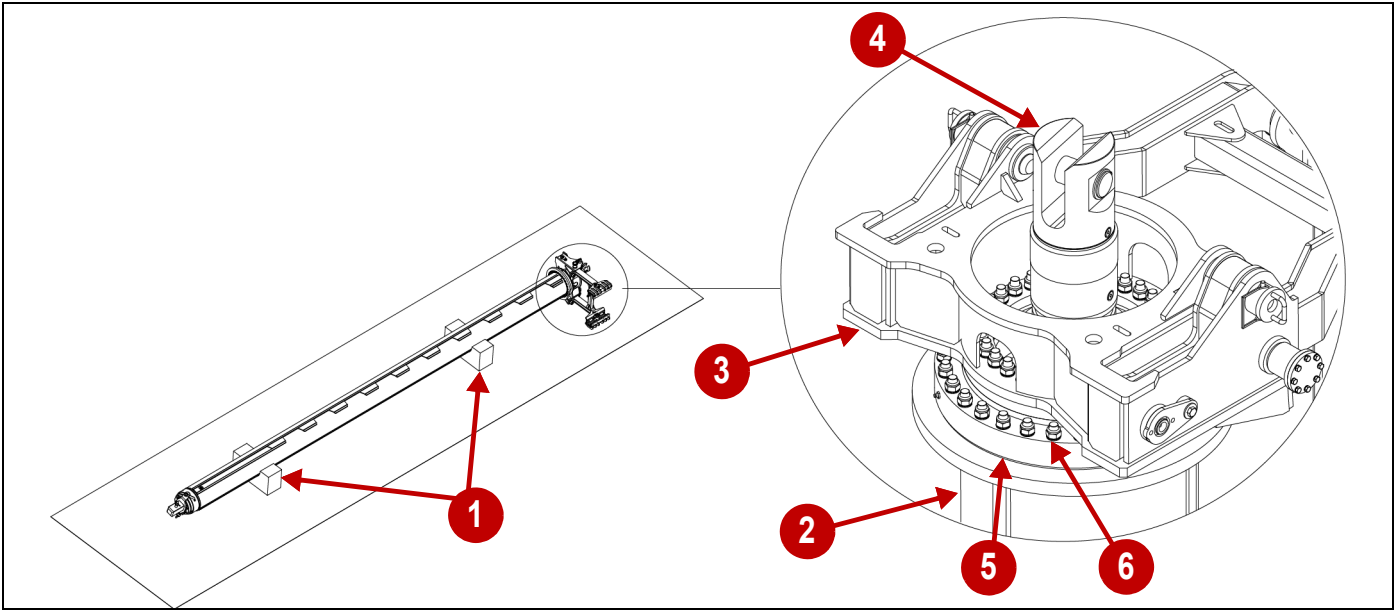

Figure 10-43

0000270

- | | | |
|-----------------------|------------|---------------------------------|
| 1) Wood Support Block | 3) A-frame | 5) Bearing |
| 2) Kelly Bar | 4) Swivel | 6) Bolts - Kelly Bar to Bearing |

WARNING

- A-frame maintenance must be performed with the A-frame at ground level.
- Review “Maintenance Safety” on page 2-50 for safety requirements before working on the drilling rig.

Failure to follow proper safety procedures may result in death or serious injury.

NOTICE

Use two wood blocks with a half-round cut in the center to cradle the kelly bar for support, make sure the kelly bar does not move during this procedure.

1. Remove the kelly bar with the A-frame. See “Kelly Bar Removal” on page 10-28.
2. With the assistance of a crane that supports the load of the kelly bar (2), or using the main winch, lay the kelly bar on the wood supports (1).
3. Position the A-frame (3) next to the kelly bar so that the A-frame is sideways and resting on the ground.
4. Support the A-frame with the auxiliary winch.

5. After making sure the kelly bar is supported and cannot move, remove the main winch cable from the swivel (4).
6. Remove all of the outer bolts (6), which connect the bearing (5) to the kelly bar.

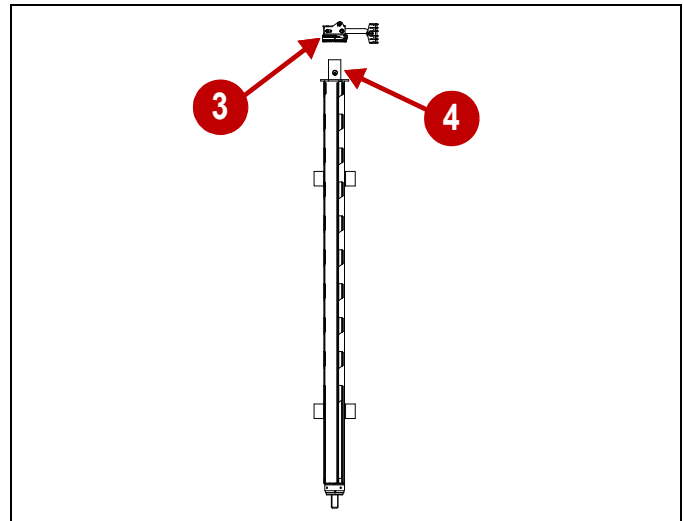

Figure 10-44

0000274

7. After ensuring both parts are correctly unbolted, carefully move the A-frame until it is clear of the swivel.

A-frame Installation

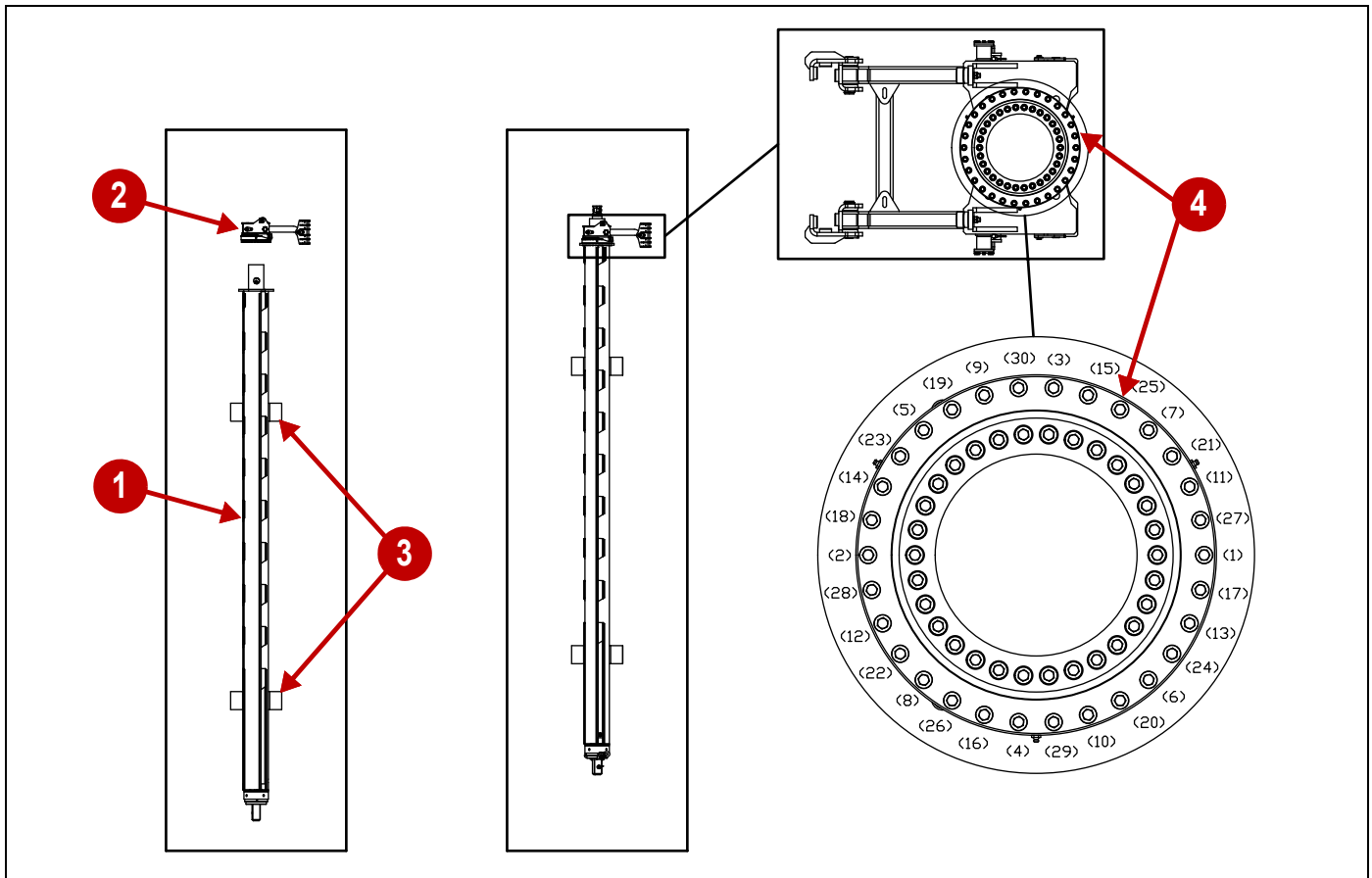

Figure 10-45

0000270

- 1) Kelly Bar 2) A-frame 3) Wood Support Block 4) Bolts - Kelly Bar to Bearing

WARNING

- A-frame maintenance must be performed with the A-frame at ground level.
- Review “Maintenance Safety” on page 2-50 for safety requirements before working on the drilling rig.

Failure to follow proper safety procedures may result in death or serious injury.

NOTICE

Use two wood blocks with a half-round cut in the center to cradle the kelly bar for support, make sure the kelly bar does not move during this procedure.

1. With the assistance of a crane that supports the load of the kelly bar, or using the main winch, lay the kelly bar on the wood support blocks (3).

2. Position the A-frame (2) next to the kelly bar so that both are concentric ensuring the A-frame is sideways and properly resting on the ground.
3. Support the A-frame with the auxiliary winch.
4. Carefully slide the A-frame in until the bearing and kelly bar are in contact and the bolt holes align.
5. Place all the bolts with washers and nuts and hand tighten them.
6. Tighten the bolts (4) in the sequence shown above. Tighten bolts to specifications. See “Torque Specifications” on page 10-99.
7. Attach the main winch cable to the swivel.
8. Install the kelly bar. See “Kelly Bar Installation” on page 10-29.

SERVICE RECOMMENDATIONS

Swivel Remove And Install

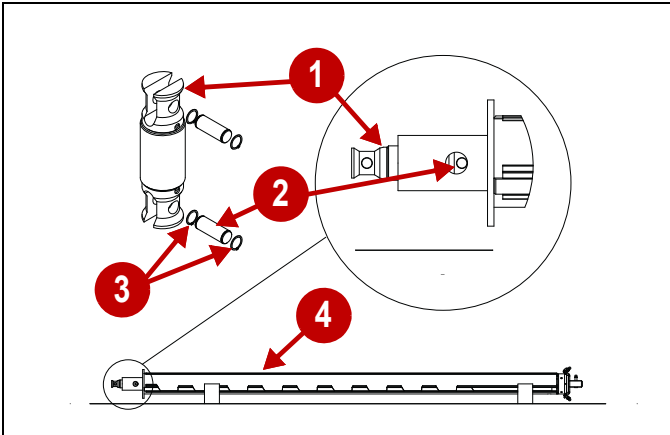

Figure 10-46

0000365

- | | |
|-----------------------|----------------------|
| 1) Swivel | 3) Snap Ring (Qty 4) |
| 2) Swivel Pin (Qty 2) | 4) Kelly Bar |

Swivel Removal

1. Prepare the machine for service. See "Prepare the Machine for Maintenance*" on page 10-5.
2. Remove the kelly bar (4). See "Kelly Bar Installation And Removal" on page 10-28.
3. Rotate the swivel (1) so that the swivel mounting pin can be accessed from the access hole in the kelly bar.
4. Remove one of the snap rings (3) securing the swivel pin (2).
5. Remove the swivel pin and swivel.

Swivel Installation

1. Position the swivel (1) in the kelly bar and align the swivel pin hole with the access hole in the kelly bar.
2. Attach one snap ring (3) on the swivel pin (2) and install the pin into the kelly bar.
3. Install the other snap ring.
4. Install the kelly bar. See "Kelly Bar Installation And Removal" on page 10-28.

Rotary Sled Wear Pad Maintenance

Wear Pad Removal

1. Remove the rotary head. See "Rotary Head Removal" on page 10-30.

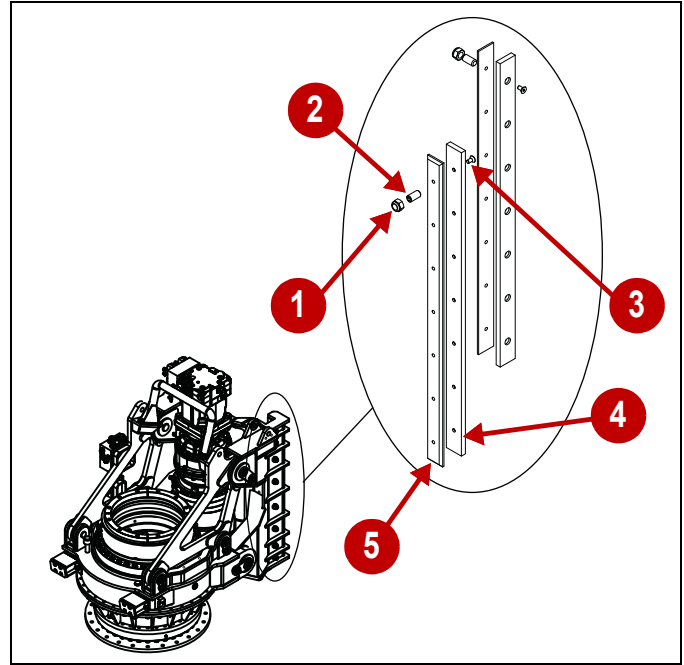

Figure 10-47

0000894

- | | |
|--------------------|------------------------|
| 1) Nylon Lock Nut | 4) Front/back Wear Pad |
| 2) Adjusting Screw | 5) Adjustment Plate |
| 3) Set Screw | |
2. Remove the set screws (3) and front/back wear pads (4).

Wear Pad Installation

1. Install the new wear pad and secure it with the set screws (3).
2. Adjust the new wear pad so there is adequate clearance when installing the rotary head on the mast.
3. Install the rotary head. See "Rotary Head Installation" on page 10-32.
4. Adjust the wear pads. See "Adjusting the Rotary Sled Wear Pads" on page 10-37.

Adjusting the Rotary Sled Wear Pads

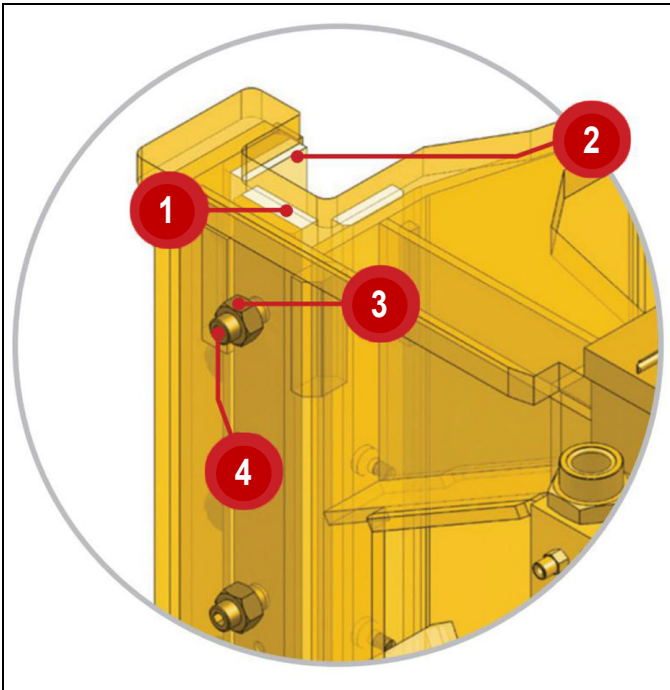

Figure 10-48

000124

- 1) Side Wear Pad
- 2) Back Wear Pad
- 3) Lock Nut
- 4) Adjusting Screw

The rotary head wear pads have an adjustment to reduce slack caused by wear of the plastic material. Adjust the sheets as follows:

1. Loosen the lock nuts and use the adjusting screws to adjust the side and back wear pads. Make sure all screws are equally tensioning the plates.
2. Lock the screws in place again using the nuts.

Replace A-frame Wear Pads

There are six wear pads (1) that allow the A-frame to slide along the mast. Each wear pad is retained by two screws.

1. Prepare the machine for service. See "Prepare the Machine for Maintenance*" on page 10-5.
2. Remove the kelly bar with A-Frame. See "Kelly Bar Installation And Removal" on page 10-28.

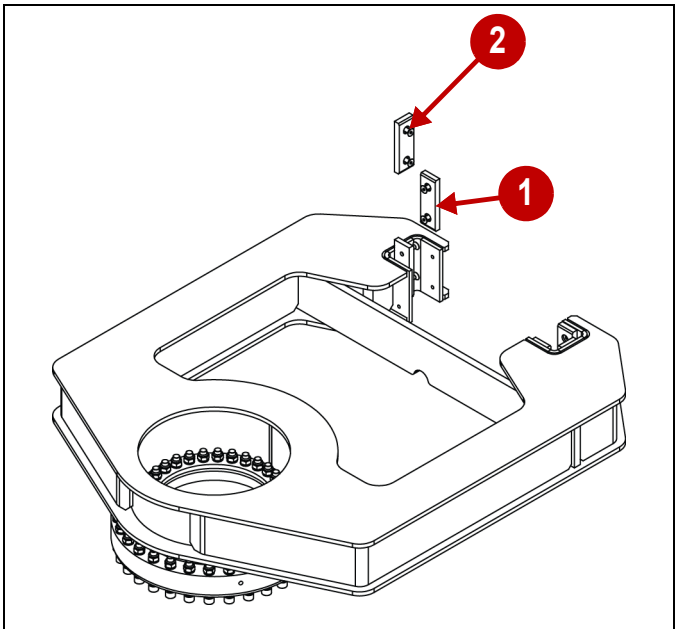

Figure 10-49

0001936

- 1) Wear Pad
 - 2) Bolt
3. Remove the two screws (2) securing each wear pad (1).
 4. Install the new wear pads.
 5. Install the kelly bar with A-Frame. See "Kelly Bar Installation And Removal" on page 10-28.

SERVICE RECOMMENDATIONS

Counterweight Remove and Install

Counterweight Removal

⚠️ WARNING

When the counterweight is removed, the stability of the machine is decreased. The drilling mast must be kept to the front of the vehicle. Avoid any sudden movements or actions that may cause the machine to tip over. Failure to follow this warning may result in death or serious injury.

1. Prepare the machine for service. See “Prepare the Machine for Maintenance*” on page 10-5.
2. Remove the kelly bar. See “Kelly Bar Installation And Removal” on page 10-28.

⚠️ WARNING

The tracks must be extended when removing and installing the counterweight. Failure to extend the tracks can cause machine instability resulting in death or serious injury.

3. Extend the tracks. See “Extend the Undercarriage Tracks” on page 8-2.
4. If the mast is in the transport position, raise it to provide adequate clearance above the counterweight.

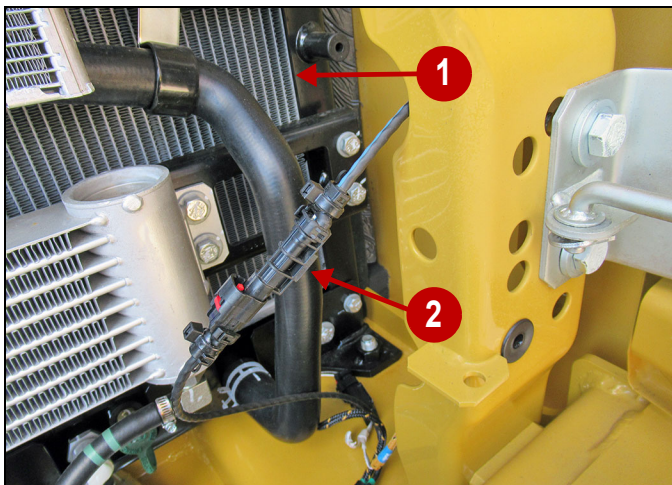

Figure 10-50

0000368

- 1) Radiator
- 2) Camera Connector
5. Disconnect the camera connector (1) from the left side compartment near the radiator (1).

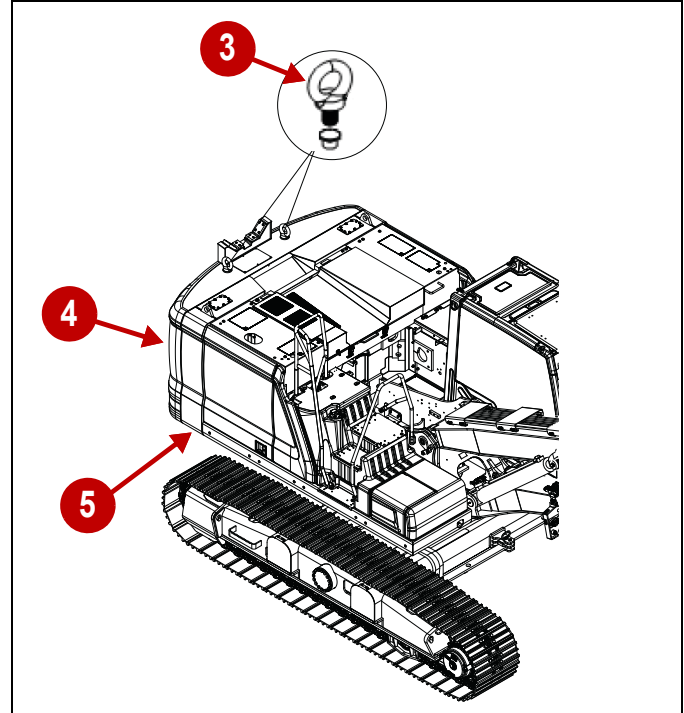

Figure 10-51

0000371

- 3) Lifting Eye Bolt
- 4) Main (CAT) Counterweight
- 5) Auxiliary Counterweight
6. If needed, install two lifting eye bolts (M42 x 4.5) on the main (CAT) counterweight.
7. Attach an appropriate lifting device to the main (CAT) counterweight. The main (CAT) counterweight weighs 14,770 lb (6700 kg).

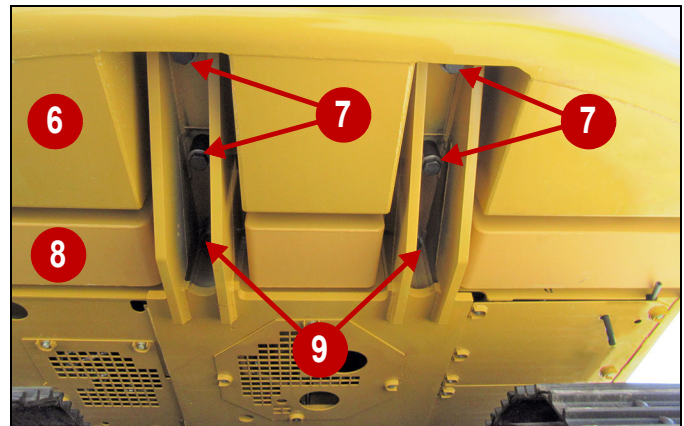

Figure 10-52

0000367

- 6) Main (CAT) Counterweight
- 7) Bolts and Spacers
- 8) Auxiliary Counterweight
- 9) Bolts and Spacers

⚠ DANGER

- During this removal procedure, the service technician must get under the counterweight to install/remove the connecting bolts while the counterweight is secured by a lifting device. Verify the lifting device and its straps/chains are rated for the weight being lifted and are not damaged.
- Do not swing or move the machine without the counterweight bolts installed.

Failure to follow these warnings will result in death or serious injury.

8. Remove four bolts and spacers (7) securing the main (CAT) counterweight.
9. Remove the main (CAT) counterweight from the machine.

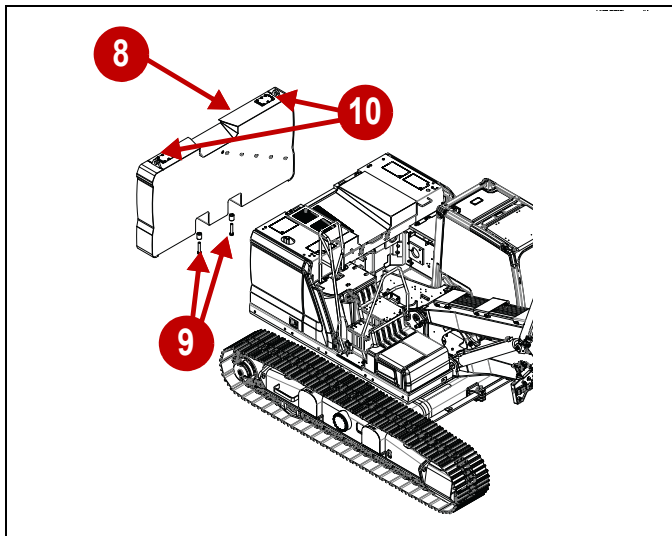

Figure 10-53

0000362

- | | |
|----------------------------|-----------------|
| 8) Auxiliary Counterweight | 10) Lifting Lug |
| 9) Bolts and Spacers | |
10. Attach a lifting device to the auxiliary counterweight (8) using the two lifting lugs (10) on top. The auxiliary counterweight weighs 2760kg (6080lb).
 11. Remove two bolts and spacers (9) from the auxiliary counterweight.
 12. Remove the auxiliary counterweight from the machine.

Counterweight Installation

⚠ DANGER

Counterweight bolts must be tightened to the correct torque. See “Torque Specifications” on page 10-99. Failure to properly tighten the counterweight bolts could result in the counterweight falling over which will result in death or serious injury.

⚠ WARNING

When the counterweight is removed, the stability of the machine is decreased. The drilling mast must be kept to the front of the vehicle. Avoid any sudden movements or actions that may cause the machine to tip over. Failure to follow this warning may result in death or serious injury.

⚠ WARNING

The tracks must be extended when removing and installing the counterweight. Failure to extend the tracks can cause machine instability resulting in death or serious injury.

1. Prepare the machine for service. See “Prepare the Machine for Maintenance*” on page 10-5.
2. Extend the tracks. See “Extend the Undercarriage Tracks” on page 8-2.

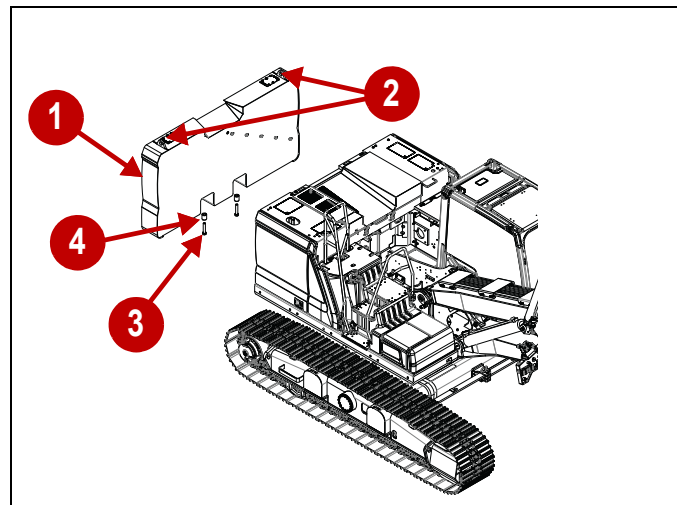

Figure 10-54

0000362

- | | |
|----------------------------|------------|
| 1) Auxiliary Counterweight | 3) Bolts |
| 2) Lifting Lug | 4) Spacers |

SERVICE RECOMMENDATIONS

3. Attach an appropriate lifting device to the 2 lifting lugs (2) on the auxiliary counterweight. The auxiliary counterweight weighs 2760kg (6080lb).
4. Lift the auxiliary counterweight into position on the machine.
5. Secure the counterweight with 2 spacers (4) and 2 bolts (3).

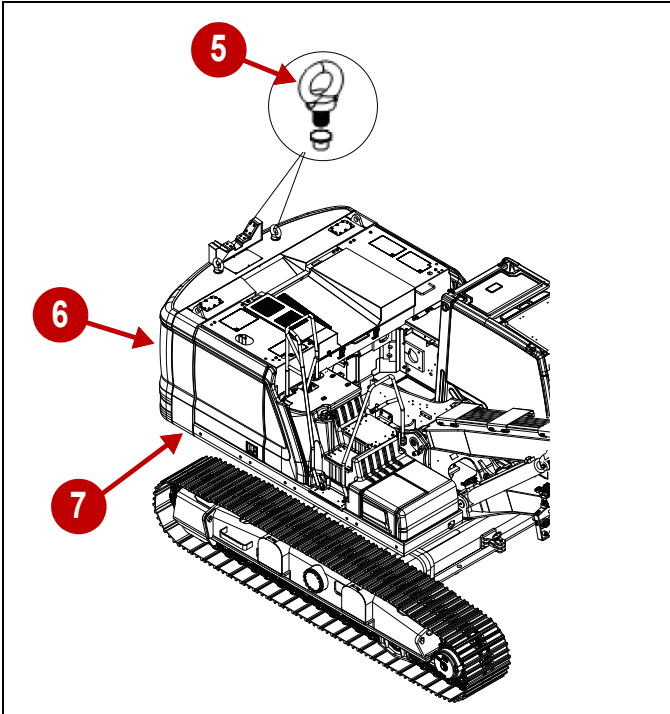

Figure 10-55

0000371

- | | |
|-----------------------------|----------------------------|
| 5) Lifting Eye Bolt | 7) Auxiliary Counterweight |
| 6) Main (CAT) Counterweight | |
6. If needed, install two lifting eye bolts (M42 x 4.5) to the main (CAT) counterweight.

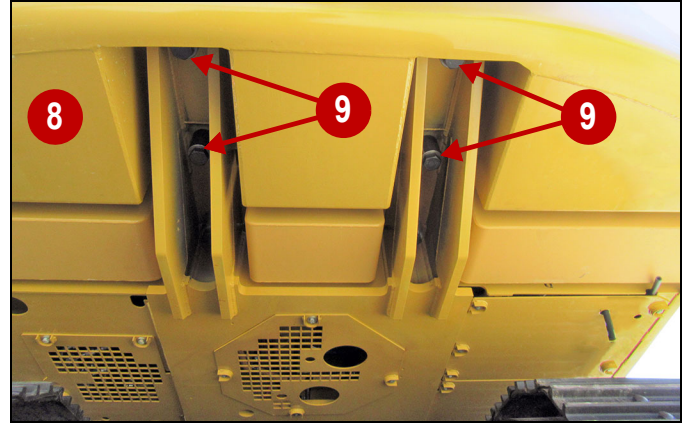

Figure 10-56

0000367

- | | |
|-----------------------------|----------------------|
| 8) Main (CAT) Counterweight | 9) Bolts and Spacers |
|-----------------------------|----------------------|
7. Use an appropriate lifting device to position the main (CAT) counterweight (8) on the machine. The main (CAT) counterweight weighs 14,770 lb (6700 kg).
8. Secure the main (CAT) counterweight with four bolts and spacers (9).

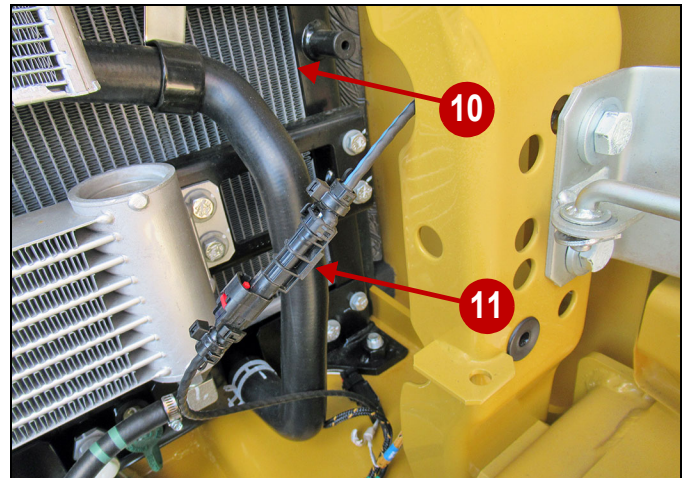

Figure 10-57

0000368

- | | |
|--------------|----------------------|
| 10) Radiator | 11) Camera Connector |
|--------------|----------------------|
9. Connect the camera connector (1) from the left side compartment near the radiator (10).

Engine Maintenance

Engine Oil Level – Check*

SMCS Code: 1000-535

⚠ WARNING

Hot oil and hot components can cause personal injury. Do not allow hot oil or hot components to contact skin.

NOTICE

Do not overfill the crankcase. Engine damage can result.

This machine is equipped with an automated function for checking fluid levels and dipsticks. Refer to “CAT® Monitoring System*” on page 6-29 regarding the automated system. If the machine is on an incline or the engine has been stopped only for a short time, all engine oil may not be in the crankcase. The fluid level cannot be properly checked by either method during these instances. Park the machine on level ground. The engine oil level can be checked after the engine has been stopped for at least 30 minutes. Do not check the oil level while the engine is running.

The machine is equipped with a ground level dipstick and a dipstick on top of the engine.

Engine Dipstick*

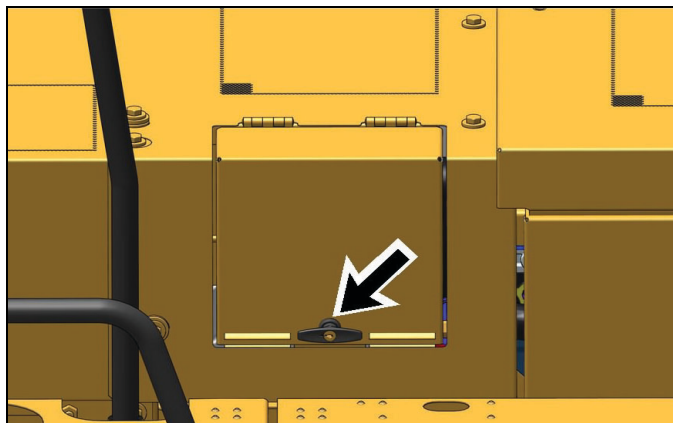

Figure 10-58

g06183460

1. Open the access door on top of the machine.

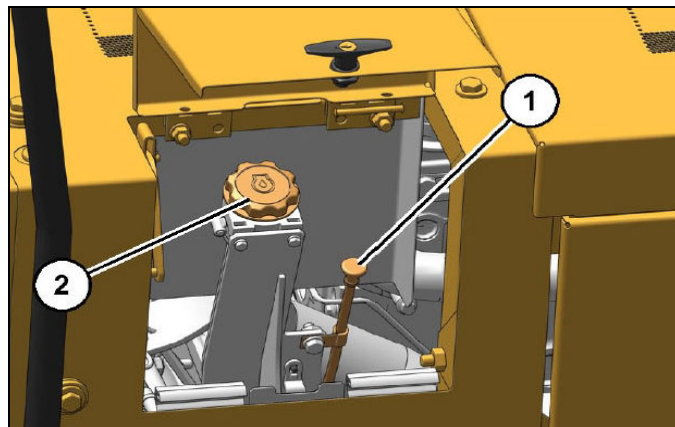

Figure 10-59

g06183463

2. Remove dipstick (1). Wipe the oil off the dipstick and reinsert the dipstick.

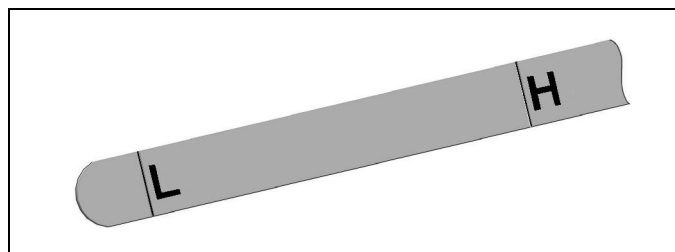

Figure 10-60

g06183475

3. Remove the dipstick and check the dipstick. The oil level should be between the “L” mark and the “H” mark.

NOTICE

Operating your engine when the oil level is above the “H” mark could cause the crankshaft to dip into the oil. This could lead to excessively high oil temperatures which can reduce the lubricating characteristics of the oil, cause bearing damage, and could result in loss of engine power.

NOTE: Refer to “General Safety*” on page 2-11 for information on Containing Fluid Spillage.

4. Remove oil filler plug (2) to add oil, if necessary. See “Fluids and Lubricants” on page 10-11.

NOTE: If the oil is deteriorated or badly contaminated, change the oil regardless of the maintenance interval.

5. Clean the oil filler plug. Install the oil filler plug.
6. Close the access door.

SERVICE RECOMMENDATIONS

Ground Level Dipstick*

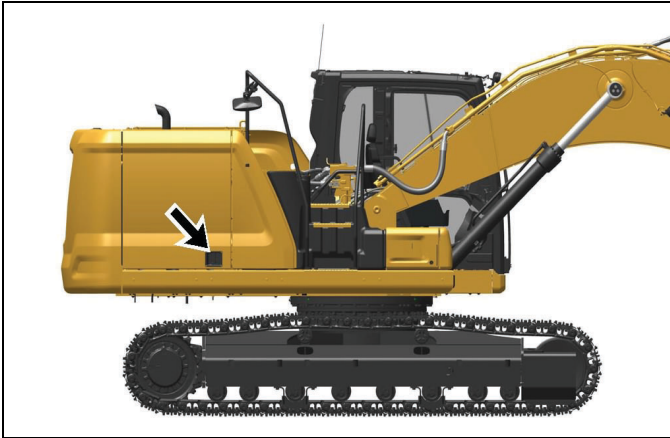

Figure 10-61

g06182545

To access the ground level dipstick, open the right access door.

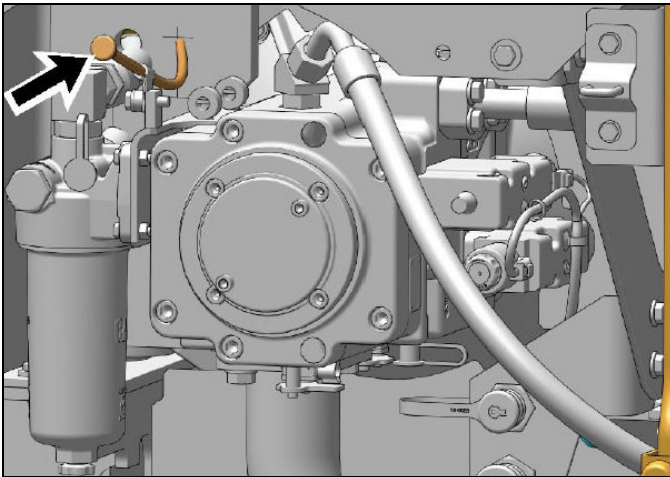

Figure 10-62

g06211545

The ground level dipstick is located near the engine oil filter and main hydraulic pump.

Engine Oil Sample – Obtain*

SMCS Code: 1000-008; 1000; 1348-554-SM; 1348-008; 7542-008; 7542-554-OC; 7542-554-SM

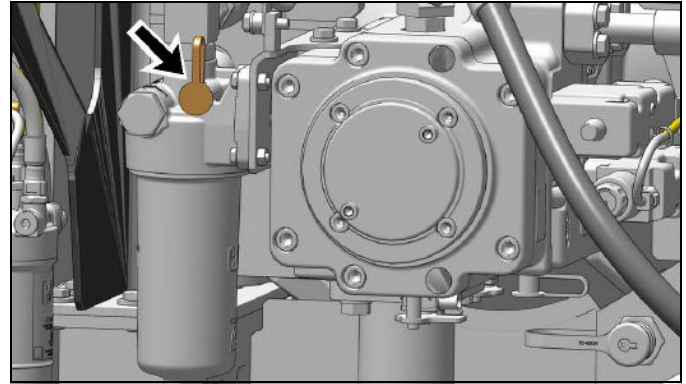

Figure 10-63

g06220379

Obtain a sample of the engine oil from the engine oil sampling valve that is located on the engine oil filter housing. If needed, contact CZM for more information about obtaining a sample of the engine oil.

Engine Oil and Filter – Change*

SMCS Code: 1318-510

Selection of the Oil Change Interval

NOTE: Machines equipped with C7.1 engine and have a fuel burn average of 11.4 L (3 US gal) per hour or less may extend engine oil and filter interval from 500 hours to 1000 hours when using specific fluids, filters, and services, contact CZM for more information.

Required oil sampling interval is every 250 hours.

Initial engine oil and filter change at 500 hours is required for engine break-in.

Changing the Engine Oil and Filter*

⚠ WARNING

Hot oil and hot components can cause personal injury. Do not allow hot oil or hot components to contact skin.

NOTICE

If the sulfur content in the fuel is greater than 1.5 percent by weight, use an oil that has a TBN of 30 and reduce the oil change interval by one-half.

NOTE: Drain the crankcase while the oil is warm. This allows waste particles that are suspended in the oil to drain. As the oil cools, the waste particles will settle to the bottom of the crankcase. The particles will not be removed by draining the oil and the particles will recirculate in the engine lubrication system with the new oil.

1. Park the machine on a level surface. Stop the engine.
2. Prepare the machine for maintenance. See “Prepare the Machine for Maintenance*” on page 10-5.

NOTE: Refer to “General Safety*” on page 2-11 for information on Containing Fluid Spillage.

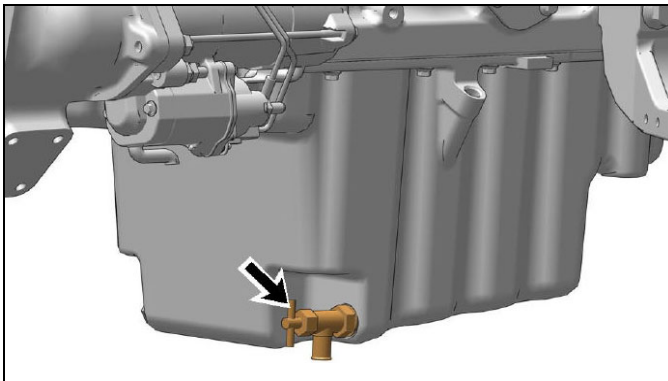

Figure 10-64

g06183508

3. Open the crankcase drain valve. Allow the oil to drain into a suitable container.

NOTE: Discard any drained fluids according to local regulations.

NOTICE

If equipped with a fast fill system, the oil can be drained and filled using the fast fill coupler. See “Fast Fill (If Equipped)*” on page 10-45.

4. Close the drain valve.

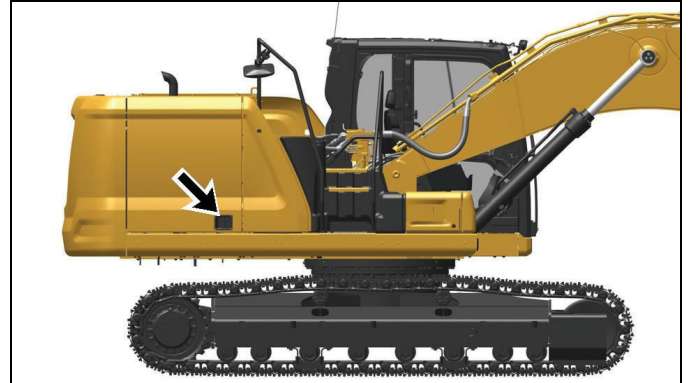

Figure 10-65

g06182545

5. Open the access door at the right side of the machine.

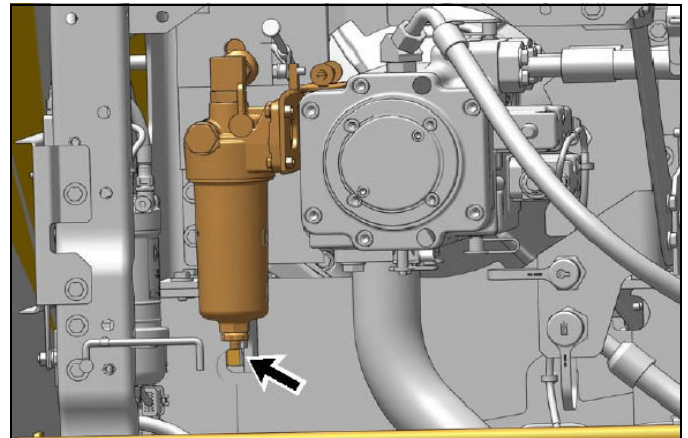

Figure 10-66

g06183511

6. Loosen drain valve and allow the oil to drain out of the housing.

NOTE: If equipped with a fast fill system, the oil can be drained and filled using the fast fill coupler. Refer to “Fast Fill (If Equipped)*” on page 10-45.

7. After all the oil has been removed, tighten the drain.
8. Remove the oil filter housing. See “Engine Oil and Filter – Change*” on page 10-42. Dispose of the used filter according to local regulations.

SERVICE RECOMMENDATIONS

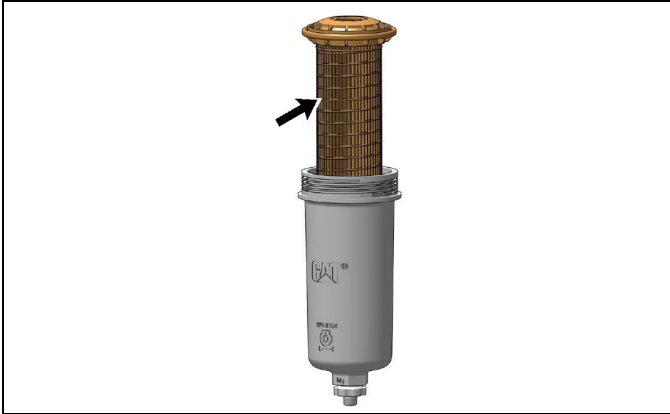

Figure 10-67

g06183515

9. Remove the filter from the housing.
10. Clean the filter housing and the base.
11. Install the new filter element into the housing.
12. Apply a thin coat of engine oil to the gasket of the new filter.
13. Install the filter housing with element to the filter base utilizing a socket wrench.

NOTE: Note: Apply a tightening torque of 90 N·m (66 lb·ft) and tighten until metal-to-metal contact is achieved.

14. Re-tighten the drain valve to a torque of 2.5 N·m (22.1 lb in.).
15. Close the access door.

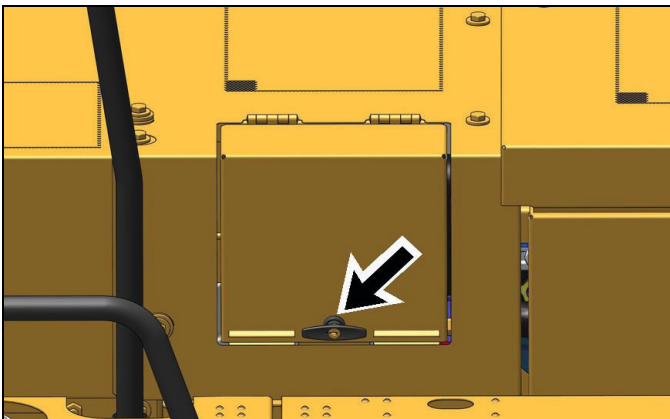

Figure 10-68

g06183460

16. Open the access door on top of the machine.

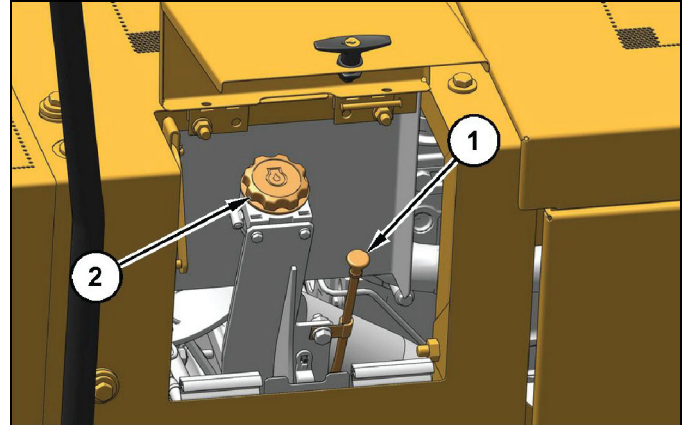

Figure 10-69

g06614930

17. Remove oil filler cap (2). Fill the crankcase with new oil. See "Fluids and Lubricants" on page 10-11.
18. Clean the oil filler cap and install the oil filler cap.

NOTICE

Do not under fill or overfill engine crankcase with oil. Either condition can cause engine damage.

19. Start the engine and allow the oil to warm. Check the engine for leaks. Stop the engine.

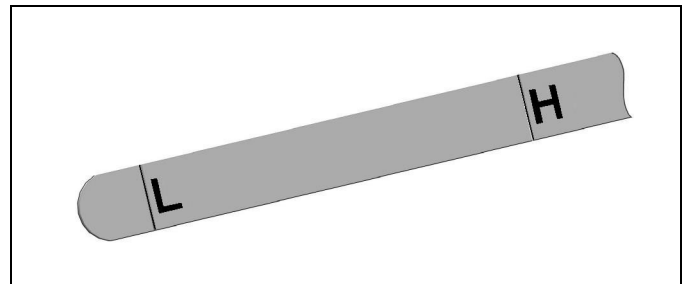

Figure 10-70

g06183475

20. Wait for 30 minutes to allow the oil to drain back into the crankcase. Check the oil level with dipstick (3). Maintain the oil between the "L". and "H". marks on the dipstick. If necessary, add oil.
21. Close the access door.

Fast Fill (If Equipped)*

If your machine is equipped with a deluxe service center, you may drain and add the engine oil through the fast fill port.

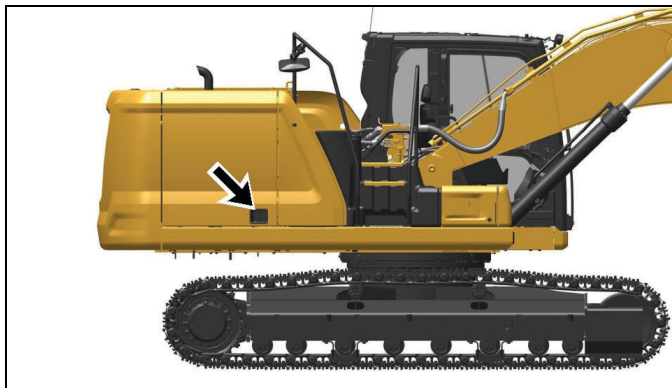

Figure 10-71

g06182545

1. Open the access door on the right side of the machine.

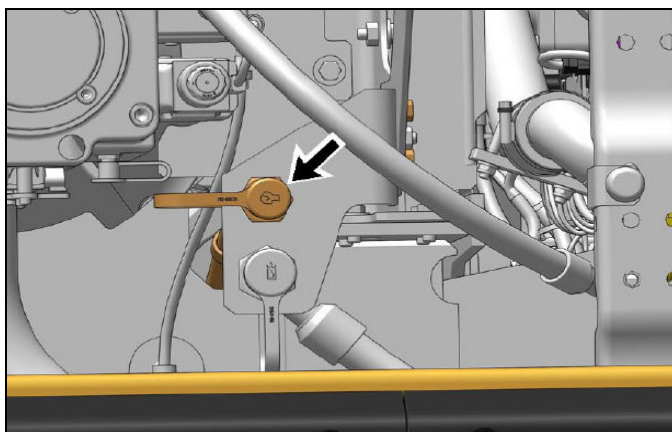

Figure 10-72

g06183504

2. Remove the dust cover.
 3. Attach a hose that is equipped with a nozzle.
- NOTE:** Make sure that the nozzle and the receiver are free from debris before attaching.
4. Drain the oil or add the oil, as needed.
 5. Install the dust cover.

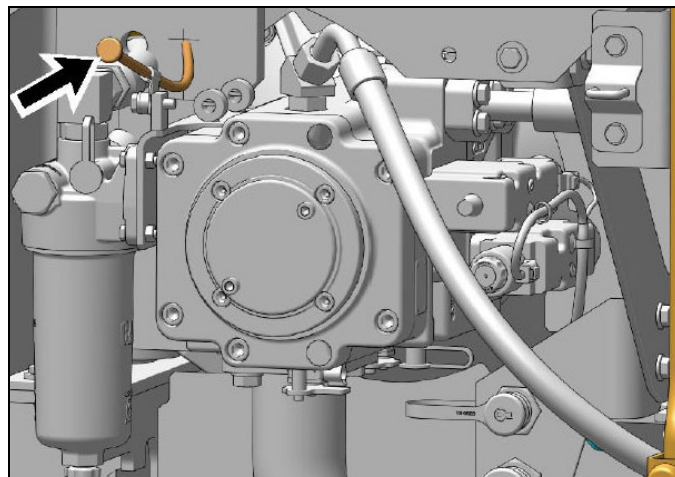

Figure 10-73

g06211545

6. Verify that the correct amount of oil was added and add or remove oil as necessary. A ground level dipstick is located in the same compartment as the fast fill port.

Engine Air Filter Primary and/ or Secondary Element – Replace*

SMCS Code: 1054-510-PY; 1054-510-SE

NOTICE

Service the air cleaner only with the engine stopped. Engine damage could result.

NOTICE

Service the engine air filter elements only when a message or a warning is displayed on the monitor display. Do not open the filter compartment unless service is indicated. Opening the filter compartment when not necessary to do so increases the chance of dirt contamination in engine air intake system components.

NOTICE

Short air filter life can result if the pre-cleaner system malfunctions. If air filter life is drastically reduced from typical for the operating conditions, contact the CZM After Sales Department.

NOTICE

Do not use the air filter elements longer than 1 year.

SERVICE RECOMMENDATIONS

Primary Air Filter Element – Replace*

The engine air cleaner assembly is located behind the front access door on the left side of the machine.

1. Park the machine on a level surface. Stop the engine.

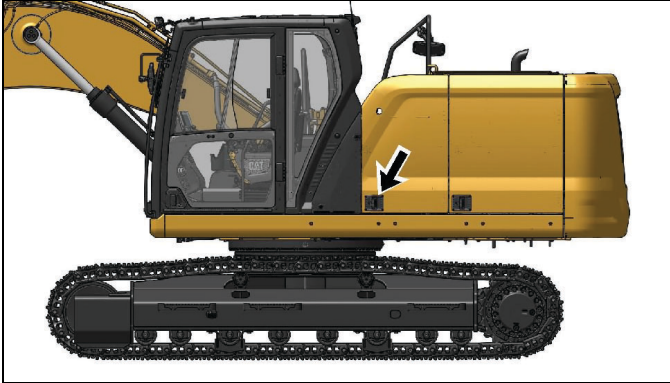

Figure 10-74

g06181546

2. Open the front access door on the left side of the machine.

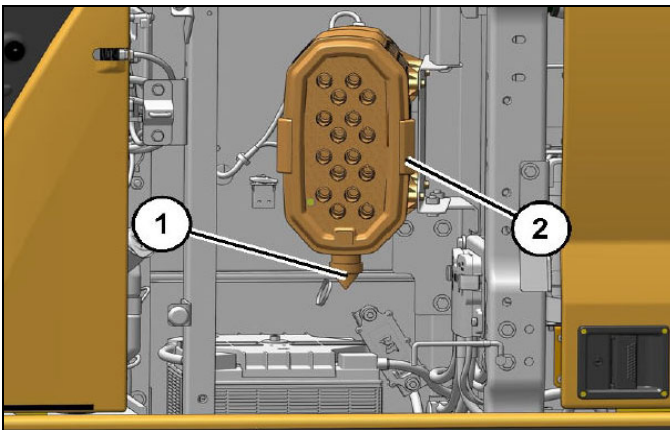

Figure 10-75

g06183302

3. Squeeze outlet tube (1) to purge the dirt from the outlet tube.

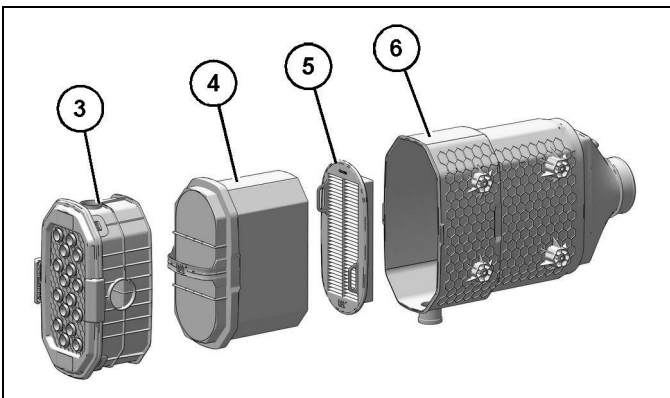

Figure 10-76

g06222467

4. Release latches (2) that secure pre-cleaner (3) to engine air filter housing (6).
5. Remove pre-cleaner (3).
6. Clean inside the air filter housing where the pre-cleaner was removed.

NOTICE

CZM does not recommend cleaning the primary air filter element. CZM only recommends to replace the primary air filter element. CZM does not cover costs for damage to engine components caused by cleaning the primary air filter element.

Observe the following guidelines if you attempt to clean the primary filter element:

Do not tap or strike the filter element in order to remove dust.

Do not wash the filter element.

Use low pressure compressed air in order to remove the dust from the filter element. Air pressure must not exceed 207 kPa (30 psi). Direct the air flow up the pleats and down the pleats from the inside of the filter element. Take extreme care in order to avoid damage to the pleats.

Do not clean the air filter element more than three times. The air filter element must be replaced if the filter has been in use for one year, regardless of the number of times the filter has been cleaned.

Do not use air filters with damaged pleats, gaskets, or seals. Dirt entering the engine will cause damage to engine components.

NOTICE

Do not clean the air filter elements by bumping or tapping. This could damage the seals. Do not use element with damaged pleats, gaskets, or seals. Damaged elements will allow dirt to pass through. Engine damage could result.

7. Remove primary air filter element (4). Replace the filter element as necessary.

NOTE: Replace the primary filter if the filter has been in use for 1 year.

8. Clean inside the air filter assembly housing.

NOTE: Do not allow any dirt or debris to contact the secondary air filter element (5).

9. Inspect the seal area ensure that no foreign debris has fallen into the seal area. Clean the air cleaner interior to remove remaining dust or debris.
10. Without removing secondary air filter element (5), inspect the filter element for damage. Replace if necessary or dirty. Refer to “Secondary Air Filter Element – Replace*”.
11. Install the secondary air filter element.
12. Install the primary filter.

NOTE: Filters must be fully installed before the pre-cleaner can be attached. If the pre-cleaner cannot be fully latched, verify that the filter elements are properly seated.

13. Install the pre-cleaner and secure the latches that hold the pre-cleaner to the air filter housing.
14. Close the access door.

Secondary Air Filter Element – Replace*

NOTICE

Always replace the secondary element. Do not attempt to reuse it by cleaning. Engine damage could result.

NOTICE

Do not use the air filter elements longer than 1 year.

NOTICE

Replace the secondary filter element when you service the primary element for the third time. If a clean primary element has been installed and the filter element indicator is still flashing, replace the secondary filter element. Also if the exhaust smoke remains black and a clean primary filter element has been installed, replace the secondary filter element.

1. Open the front access door on the left side of the machine.
2. Refer to the section “Primary Air Filter Element – Replace”. Remove the pre-cleaner from the engine air filter housing. Remove the primary air filter element from the air filter housing.

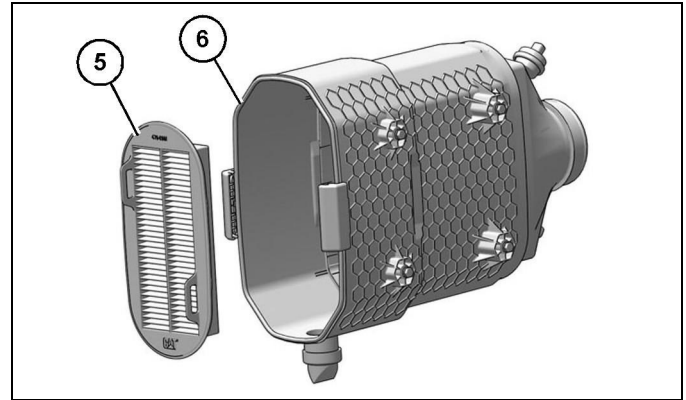

Figure 10-77

g06183315

3. Secondary air filter element (5) is pressed into the rear portion of engine air filter housing (6). Pull forward on the secondary air filter element to remove the element from the engine air filter housing.
 4. Cover the air inlet opening. Clean inside the air cleaner housing.
 5. Clean all surfaces of the pre-cleaner cover and body.
 6. Uncover the air inlet opening.
 7. Carefully press the secondary air filter element into the rear portion of the engine air filter housing.
- NOTE:** Be certain that the new secondary air filter element is properly seated in the filter housing. Also, check to see that no damage to the filter element has occurred during installation.
8. Install the primary air filter element and the pre-cleaner.
 9. Close the access door.

SERVICE RECOMMENDATIONS

Engine Air Pre-Cleaner – Clean*

NOTE: Do not attempt to clean the pre-cleaner by hitting the filter against another object. Damage to the filter is likely to occur.

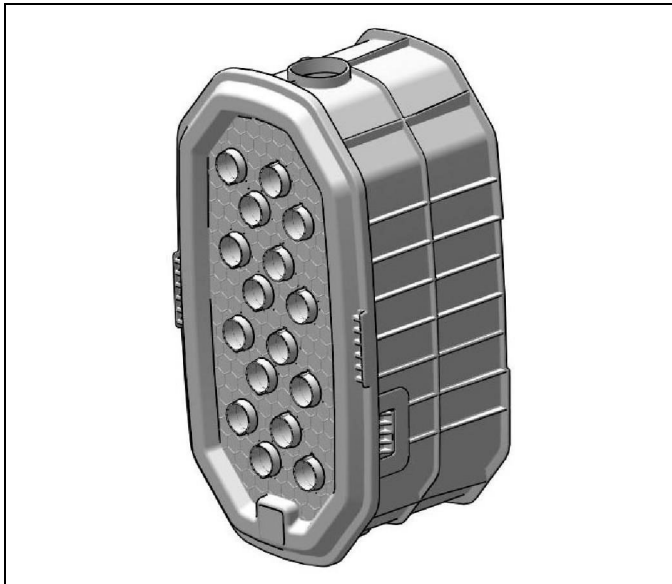

g06183310

Figure 10-78: Engine Air Pre-Cleaner

After removing the pre-cleaner from the air filter housing, inspect the interior of the pre-cleaner through the ejection ports around the perimeter.

In general, dust and debris will clear automatically through normal pre-cleaner operation and no further service will be required.

If the ejection ports are blocked, or dust is packed between the pre-cleaner tubes, first try to clear any accumulation by vigorously shaking the pre-cleaner.

If the pre-cleaner is still blocked with dirt, the pre-cleaner may be separated by releasing the snap features holding the front cover to the pre-cleaner body.



g06069263

Figure 10-79

1. Place the pre-cleaner assembly on a suitable work surface. The interior of the pre-cleaner may have accumulated debris. Protect your work surface to collect excess debris and to avoid scattering debris.

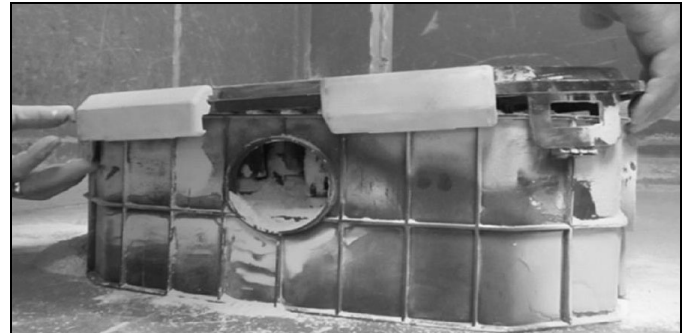

g06069266

Figure 10-80

2. Lift the locking tabs on one end of the cover away from the retainers. Move the locking tabs only far enough to clear the retention posts.

NOTICE

Do not bend the locking tabs farther than necessary to release the tabs. Damage to the air cleaner can result. Do not use tools to force the snap features off the retainers.

3. Pull one end of the top cover away from the bottom half.
4. Hold one end of the cover sections apart and separate one of the locking tabs on the other end of the pre-cleaner.



g06069264

Figure 10-81

5. Pull the top cover up and away from the bottom.
6. Clear any blockage by shaking the pre-cleaner components and/or brushing away accumulated debris.

NOTICE

Do not use picks or other stiff implements to clear debris, you may damage the pre-cleaner components.

NOTICE

Do not attempt to remove the pre-cleaner tubes from the top cover or you will damage the air cleaner.

7. If the blockage is still not cleared, you may attempt to clear the debris by use of an air nozzle limited to 207 kPa (30 psi).
Alternately, each part of the pre-cleaner may be submerged in water to loosen mud or other debris that may have dried on the interior surface of the air cleaner.

NOTICE

Never attempt to use a pressure washer or other high-pressure water sources to clean the pre-cleaner. Use of high-pressure water may damage the pre-cleaner tubes and reduce the pre-cleaner effectiveness.

8. After cleaning, reassemble the pre-cleaner by lining up the tubes on the pre-cleaner top with the tubes in the pre-cleaner bottom.
9. Allow the pre-cleaner top to rest on the pre-cleaner bottom and ensure that the four snap features are aligned.



Figure 10-82

g06069247

10. If all the tabs are aligned, gently push the pre-cleaner top down into place. Ensure that all the snap features have engaged.

Before installing the pre-cleaner to the air filter housing, inspect the pre-cleaner gasket for damage. Replace if damaged.

Fumes Disposal Filter Element – Replace*

SMCS Code: 1074

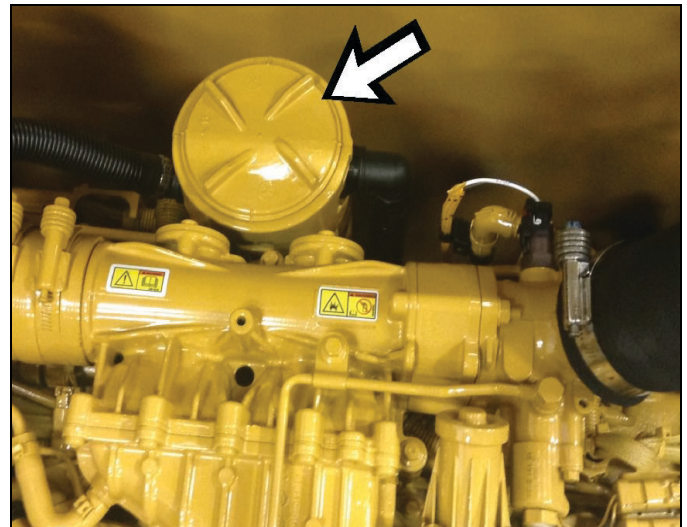

g06209196

Figure 10-83: Typical Example

NOTE: Perform the maintenance with the engine shut off.

1. Open the engine hood.
2. Remove the lid that holds the canister to the filter base assembly.
3. Remove the filter element. Dispose of the used element properly.
4. Install the new filter.
5. Install the lid.
6. Close the engine hood.

SERVICE RECOMMENDATIONS

Cooling System Coolant (ELC) – Change*

SMCS Code: 1350-044

⚠ WARNING

Engine hood and engine hood parts can be hot while engine is running or immediately after engine shutdown. Hot parts or hot components can cause burns or personal injury. Do not allow these parts to contact your skin, when engine is running or immediately after engine shutdown.

Use protective clothing or protective equipment to protect your skin.

⚠ WARNING

Personal injury can result from hot coolant, steam, and alkali.

At operating temperature, engine coolant is hot and under pressure. The radiator and all lines to heaters or the engine contain hot coolant or steam. Any contact can cause severe burns.

Remove cooling system pressure cap slowly to relieve pressure only when engine is stopped and cooling system pressure cap is cool enough to touch with your bare hand.

Do not attempt to tighten hose connections when the coolant is hot, the hose can come off causing burns.

Cooling system coolant additive contains alkali. Avoid contact with skin and eyes.

NOTICE

Do not change the coolant until you first contact the CZM After Sales Department for machine fluid recommendations”.

Failure to do so could result in damage to the cooling system components.

NOTICE

Mixing ELC with other products will reduce the effectiveness of the coolant.

This could result in damage to cooling system components.

If CZM recommended products are not available and commercial products must be used, contact CZM After Sales Department for approval of premixed or concentrate coolants and extender.

NOTE: This machine was filled at the factory with Extended Life Coolant.

NOTE: If the coolant in the machine is changed to Extended Life Coolant from another type of coolant, contact the CZM After Sales Department for recommendations.

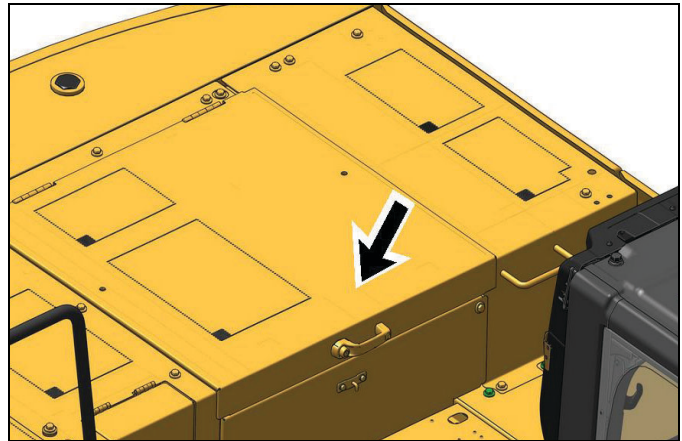

Figure 10-84

g06225770

1. Unlatch the engine hood and raise the engine hood.

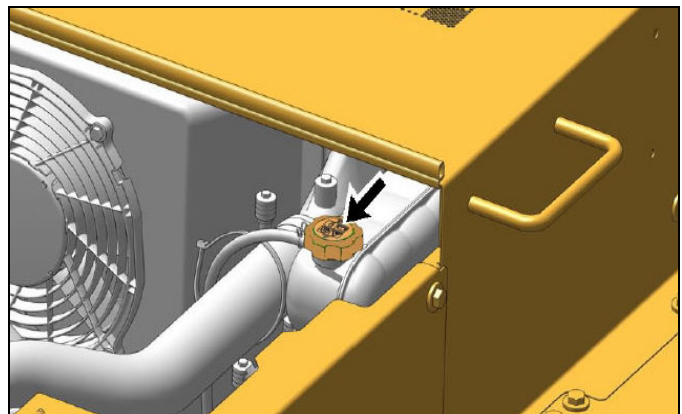

Figure 10-85

g06183808

2. Slowly loosen the pressure cap that is on the coolant reservoir to release pressure from the cooling system.

SERVICE RECOMMENDATIONS

3. Remove the pressure cap.
4. Inspect the gasket on the pressure cap. If the gasket is damaged, replace the pressure cap.

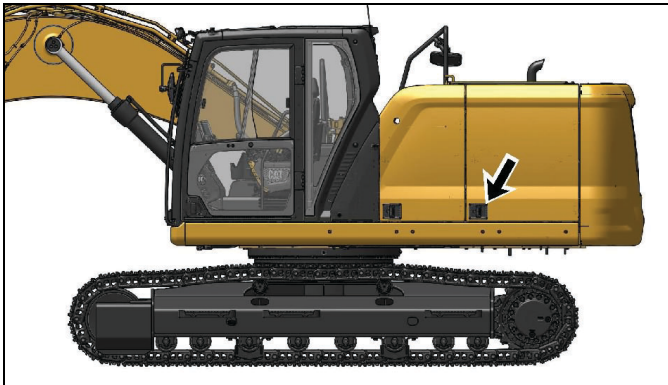

Figure 10-86

g06179792

5. Open the rear access door on the left side of the machine.

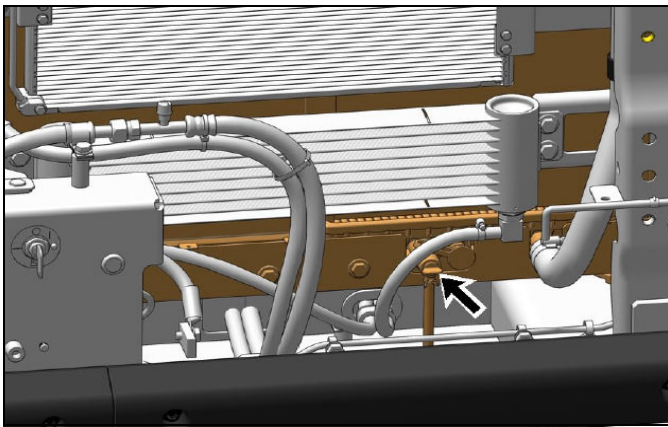

Figure 10-87

g06183531

6. Open the drain valve and allow the coolant to drain into a suitable container. The drain valve is on the bottom of the radiator. Properly dispose of used coolant.
7. Flush the cooling system. Follow Step 7a through Step 7h to flush the cooling system.
 - a. Close the drain valve.
 - b. Fill the cooling system with clean water.
 - c. Install the pressure cap.
 - d. Start the engine and run the engine until the engine reaches operating temperature.
 - e. Stop the engine and allow the engine to cool.
 - f. Loosen the pressure cap slowly to relieve any pressure in the cooling system.
 - g. Open the drain valve that is on the bottom of the radiator and allow the coolant to drain into a suitable container.

- h. Flush the radiator with clean water until the draining water is transparent.
8. Close the drain valve.
9. Add the Extended Life Coolant. Refer to “Fluids and Lubricants” on page 10-11.
10. After the cooling system has been filled, perform the following procedures during initial start-up:
 - a. Start the engine without the filler cap.
 - b. Run the engine at low idle for 10 minutes.
 - c. Then, increase the engine speed to a high idle until the water temperature regulator is open and the coolant level is stabilized.
 - d. Maintain the coolant at the proper level as the water temperature regulator opens and air is purged from the system. Refer to “Cooling System Coolant Level – Check*” on page 10-53.
11. Install the cooling system pressure cap.
12. Stop the engine.

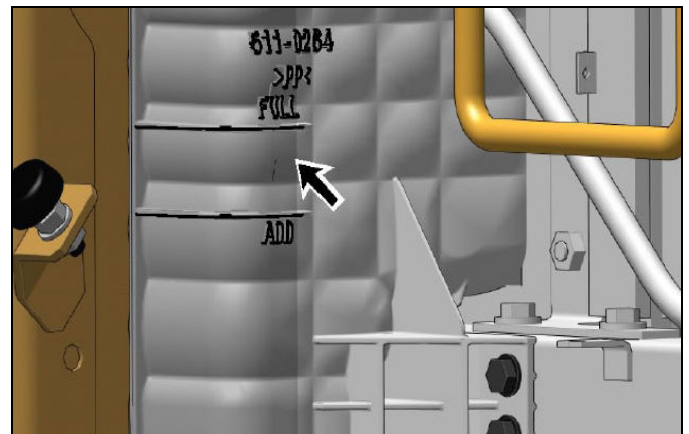

Figure 10-88

g06205196

13. Check the coolant reservoir. Maintain the coolant level so that coolant is between the “ADD” and “FULL” lines. If more coolant is needed, see “Cooling System Coolant Extender (ELC) – Add*” on page 10-52.
14. If more coolant is necessary, remove the pressure cap and add the appropriate coolant solution.
15. Install the pressure cap.
16. Close and latch the engine hood. Close the left access door.

SERVICE RECOMMENDATIONS

Cooling System Coolant Extender (ELC) – Add*

SMCS Code: 1352; 1353; 1395

⚠ WARNING

Engine hood and engine hood parts can be hot while engine is running or immediately after engine shutdown. Hot parts or hot components can cause burns or personal injury. Do not allow these parts to contact your skin, when engine is running or immediately after engine shutdown. Use protective clothing or protective equipment to protect your skin.

⚠ WARNING

Personal injury can result from hot coolant, steam and alkali.

At operating temperature, engine coolant is hot and under pressure. The radiator and all lines to heaters or the engine contain hot coolant or steam. Any contact can cause severe burns.

Remove cooling system pressure cap slowly to relieve pressure only when engine is stopped and cooling system pressure cap is cool enough to touch with your bare hand.

Do not attempt to tighten hose connections when the coolant is hot, the hose can come off causing burns.

Cooling system coolant additive contains alkali. Avoid contact with skin and eyes.

NOTICE

Use Extended Life Coolant (ELC) when you add coolant to the cooling system. Contact CZM After Sales Department for all cooling system questions.

Use a coolant conditioner test kit to check the concentration of the coolant.

NOTICE

Mixing ELC with other products will reduce the effectiveness of the coolant.

This could result in damage to cooling system components.

If CZM recommended products are not available and commercial products must be used, contact the CZM After Sales Department for approval of premixed or concentrate coolants and extender.

NOTE: This machine was filled at the factory with Extended Life Coolant.

1. Park the machine on level ground.
2. Stop the engine.

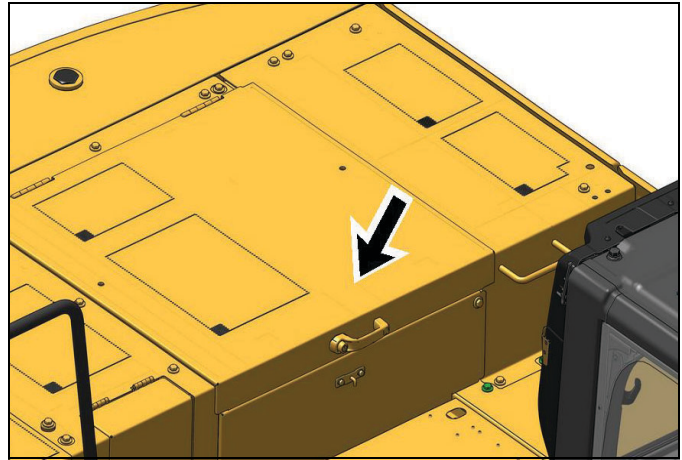

Figure 10-89

g06225770

3. Unlatch the engine hood and raise the hood.

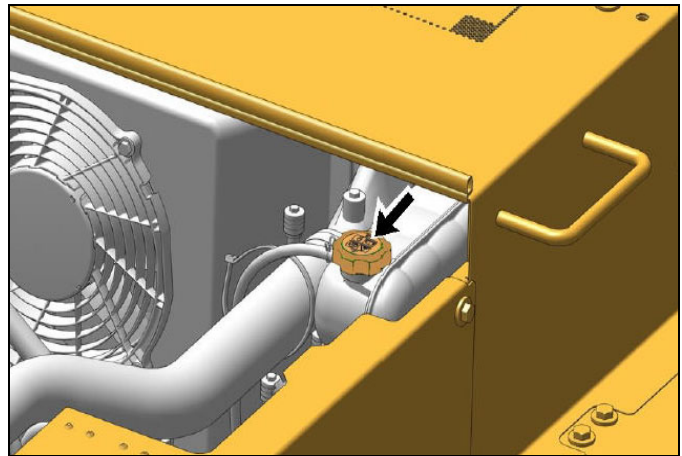



Figure 10-90

g06183808

4. Make sure that the cooling system has cooled down. Loosen the cooling system pressure cap slowly to relieve system pressure. Remove the pressure cap.

- You may need to drain some coolant from the radiator so that coolant extender can be added to the cooling system.

NOTE:  Always discard drained fluids according to local regulations.

- Add Extended Life Coolant (ELC) to the cooling system. Refer to “Fluids and Lubricants” on page 10-11.
- Inspect the O-ring of the cooling system pressure cap. If the O-ring is damaged, replace the pressure cap.
- Install the cooling system pressure cap.
- Close and latch the engine hood.

Cooling System Coolant Level – Check*

SMCS Code: 1350-040; 1350-535-FLV; 1395-535-FLV

WARNING

Engine hood and engine hood parts can be hot while engine is running or immediately after engine shutdown. Hot parts or hot components can cause burns or personal injury. Do not allow these parts to contact your skin, when engine is running or immediately after engine shutdown. Use protective clothing or protective equipment to protect your skin.

WARNING

Personal injury can result from hot coolant, steam and alkali.

At operating temperature, engine coolant is hot and under pressure. The radiator and all lines to heaters or the engine contain hot coolant or steam. Any contact can cause severe burns.

Remove cooling system pressure cap slowly to relieve pressure only when engine is stopped and cooling system pressure cap is cool enough to touch with your bare hand.

Do not attempt to tighten hose connections when the coolant is hot, the hose can come off causing burns.

Cooling system coolant additive contains alkali. Avoid contact with skin and eyes.

- Park the machine on level ground.

- Stop the engine.
- Open the rear access door on the left side of the machine.

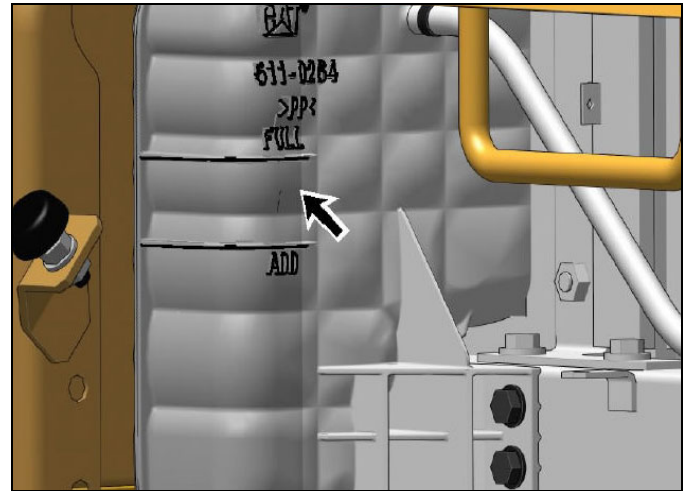

Figure 10-91

g06205196

- Maintain the coolant level so that coolant is between the “ADD” and “FULL” marks. If more coolant is needed, see “Cooling System Coolant Extender (ELC) – Add*” on page 10-52.
- Close the access door.

Cooling System Coolant Sample (Level 1) – Obtain*

SMCS Code: 1395-554; 1395-008; 7542

NOTICE

It is not necessary to obtain a Coolant Sample (Level 1) if the cooling system is filled with ELC (Extended Life Coolant). Cooling systems that are filled with ELC should have a Coolant Sample (Level 2) that is obtained at the recommended interval that as stated in the Maintenance Interval Schedule.

Obtain a Coolant Sample (Level 1) if the cooling system is filled with any other coolant instead of an ELC coolant. This includes the following types of coolants:

- Commercial long life coolants
- Diesel Engine Antifreeze/Coolant (DEAC)
- Commercial heavy-duty coolant/antifreeze

Level 1 results may indicate a need for Level 2 Analysis.

SERVICE RECOMMENDATIONS

NOTICE

Always use a designated pump for oil sampling, and use a separate designated pump for coolant sampling. Using the same pump for both types of samples may contaminate the samples that are being drawn. This contaminate may cause a false analysis and an incorrect interpretation that could lead to concerns by both dealers and customers.

NOTICE

 Care must be taken to ensure that fluids are contained during performance of inspection, maintenance, testing, adjusting, and repair of the machine. Be prepared to collect the fluid with suitable containers before opening any compartment or disassembling any component containing fluids.

Contact the CZM After Sales Department for tools and supplies suitable to collect and contain fluids on CZM products.

Dispose of all fluids according to local regulations and mandates.



Figure 10-92

g06179792

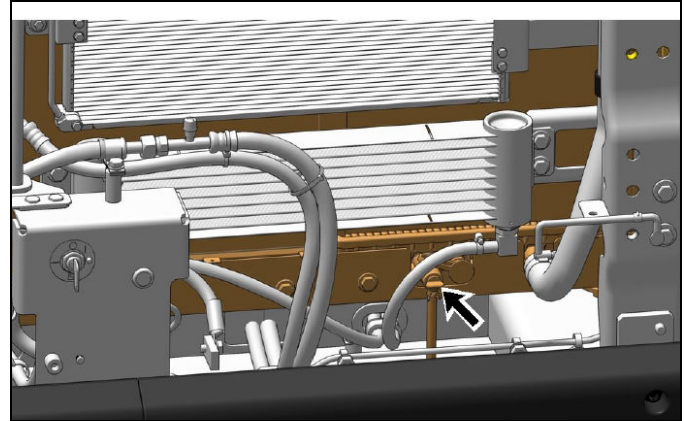

Figure 10-93

g06183525

The coolant sampling port is on the radiator.

Obtain the sample of the coolant as close as possible to the recommended sampling interval. To receive the full effect of S·O·S analysis, a consistent trend of data must be established. To establish a pertinent history of data, perform consistent samplings that are evenly spaced. Supplies for collecting samples can be obtained from CZM.

Use the following guidelines for proper sampling of the coolant:

- Complete the information on the label for the sampling bottle before you begin to take the samples.
- Keep the unused sampling bottles stored in plastic bags.
- Obtain coolant samples directly from the coolant sample port. You should not obtain the samples from any other location.
- Keep the lids on empty sampling bottles until you are ready to collect the sample.
- Place the sample in the mailing tube immediately after obtaining the sample to avoid contamination.
- Never collect samples from expansion bottles.
- Never collect samples from the drain for a system.

Submit the sample for Level 1 analysis.

For additional information about coolant analysis, contact CZM.

Cooling System Coolant Sample (Level 2) – Obtain*

SMCS Code: 1395-008; 1395-554; 7542

Reference: Refer to “Cooling System Coolant Sample (Level 1) – Obtain*” on page 10-53 for the guidelines for proper sampling of the coolant.

Obtain the sample of the coolant as close as possible to the recommended sampling interval. Supplies for collecting samples can be obtained from CZM.

Submit the sample for Level 2 analysis.

Reference: For additional information about coolant analysis, contact CZM.

Belt - Inspect/Adjust/Replace*

SMCS Code: 1357-040; 1357-510; 1357-025; 1397-025; 1397-040; 1397-510

NOTICE

This engine is equipped with a belt tightener that automatically adjusts the belt to the correct tension.

1. Unlatch the engine hood and raise the engine hood.

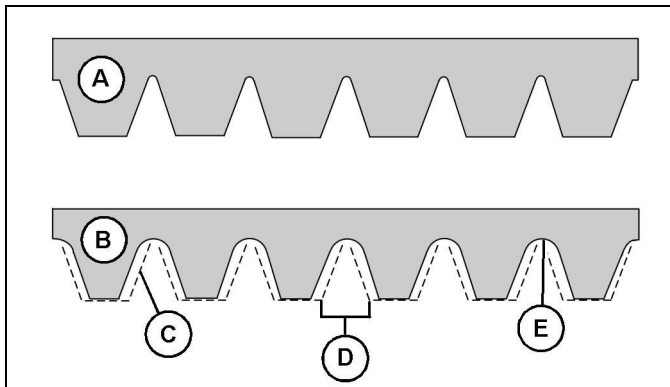

Figure 10-94

2. Inspect the condition of the serpentine belt. Over time the belt ribs will lose material (C). The space between the ribs will increase (D). The loss of material will cause the pulley sheave to contact the belt valley. This will lead to belt slippage and accelerated wear (E). Replace the belt if the belt is worn or frayed.
3. If the belt requires replacement, perform Step 3a through Step 3f.
 - a. Remove the upper fan guard.

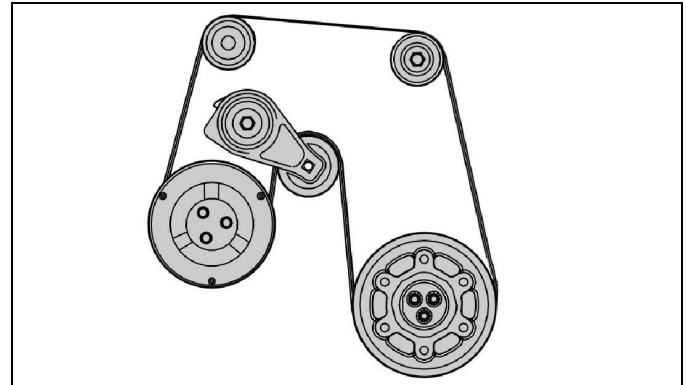

Figure 10-95

g06206669

- b. Rotate the belt tensioner clockwise to remove the belt.
- c. Remove the belt.
- d. Install a new belt.
- e. Rotate the belt tensioner clockwise to install the belt.
- f. Install the upper fan guard.

Lower the engine hood and latch the engine hood.

Ether Starting Aid Cylinder (If Equipped)*

SMCS Code: 1456-510-CD

WARNING

Breathing ether vapors or repeated contact of ether with skin can cause personal injury. Personal injury may occur from failure to adhere to the following procedures:

- Use ether only in well-ventilated areas.
- Do not smoke while replacing an ether cylinder.
- Ether is flammable and poisonous. Use ether with care to avoid fires.
- Do not store ether cylinders in living areas or in the operator compartment of a machine.
- Do not store ether cylinders in direct sunlight or temperatures above 49° C (120.2° F).
- Discard cylinders in a safe place. Do not puncture or burn cylinders.
- Keep ether cylinders out of the reach of unauthorized personnel.

SERVICE RECOMMENDATIONS

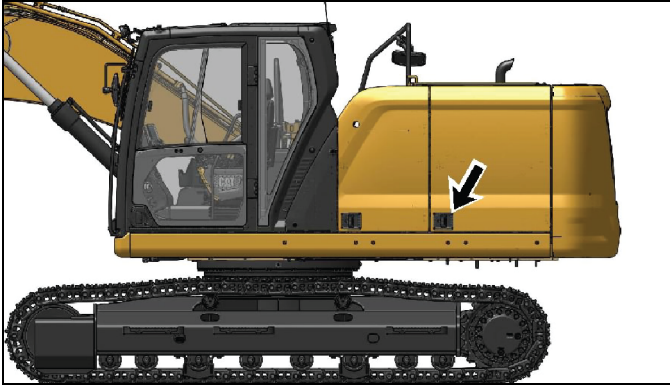

Figure 10-96

g06179792

The ether cylinder is located inside the rear access door on the left side of the machine.

Refer to “Fire Prevention and Explosion Prevention*” on page 2-23 and “Ether*” on page 2-28 before you replace the ether cylinder.

1. Open the rear access door at the left side of the machine.

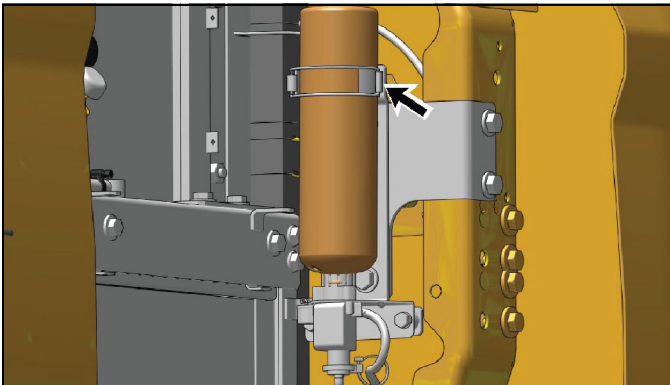

Figure 10-97

g06211094

2. Loosen the cylinder retaining clamp.
3. Unscrew the empty ether starting aid cylinder and remove the empty ether starting aid cylinder.

Radiator, Aftercooler and Oil Cooler Cores – Clean*

SMCS Code: 1063-070-KO; 1353-070-KO; 1374-070-KO

⚠ WARNING

Personal injury can result from air pressure.

Personal injury can result without following proper procedure. When using pressure air, wear a protective face shield and protective clothing.

Maximum air pressure at the nozzle must be less than 205 kPa (30 psi) for cleaning purposes.



Figure 10-98

g06179792

1. Open the access door on the left side of the machine.

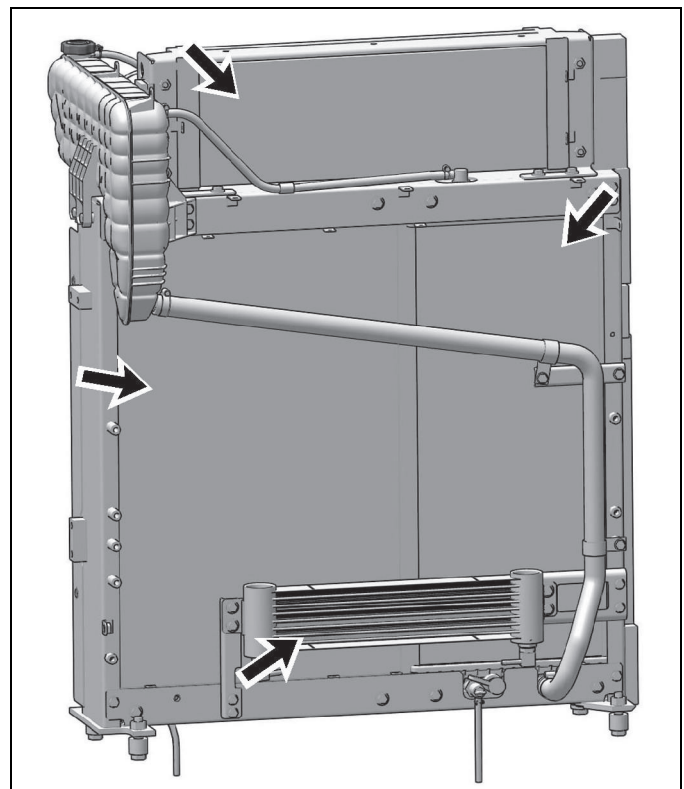

Figure 10-99

g06183814

2. Remove dust and debris from all the core fins. Compressed air is preferred, but high-pressure water or steam can be used to remove dust and general debris from a core.

Contact the CZM After Sales Department for more detailed information about cleaning core fins.

Close the access door on the left side of the machine.

Fuel System

Fuel Cap Filter – Replace*

SMCS Code: 1261-510

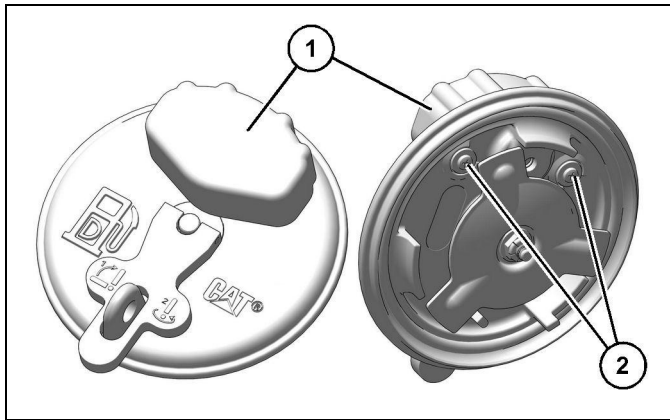

g06220524

Figure 10-100: Fuel System - Fuel Cap

1. Remove the fuel cap.
2. Remove filter element screws (2) from the underside of the fuel cap and remove filter element (1).
3. Install a clean fuel cap filter element.
4. Install the screws to secure the filter element to the fuel cap.
5. Install the fuel tank cap.

Fuel System – Prime*

SMCS Code: 1250-548

WARNING

Fuel leaked or spilled onto hot surfaces or electrical components can cause a fire. To help prevent possible injury, turn the start switch off when changing fuel filters or water separator elements. Clean up fuel spills immediately.

NOTICE

Care must be taken to ensure that fluids are contained during performance of inspection, maintenance, testing, adjusting, and repair of the machine. Be prepared to collect the fluid with suitable containers before opening any compartment or disassembling any component containing fluids.

Contact CZM After Sales Department for tools and supplies suitable to collect and contain fluids on CZM products.

Dispose of all fluids according to local regulations and mandates.

NOTICE

Do not loosen the fuel lines at the fuel manifold. The fittings may be damaged and/or a loss of priming pressure may occur when the fuel lines are loosened.

NOTICE

Do not allow dirt to enter the fuel system. Thoroughly clean the area around a fuel system component that will be disconnected. Fit a suitable cover over any disconnected fuel system components.

Prime the fuel system in order to fill the fuel filter, and prime the fuel system in order to purge trapped air.

The fuel system should be primed under the following conditions:

- The fuel tank is running low.
 - The machine has been stored.
 - The fuel filter is being replaced.
1. Turn the engine start switch to the ON position. Leave the engine start switch in the ON position for 2 minutes.
 2. Verify that the water separator is full of fuel.
 3. If the water separator is not full of fuel, turn the engine start switch OFF and then turn the engine start switch ON. Turning the engine start switch off and on will cycle the fuel priming pump again.
 4. When the water separator is full of fuel, attempt to start the engine. If the engine starts and the engine runs rough or the engine misfires, operate at low idle until the engine is running smoothly. If the engine cannot be started, or if the engine continues to misfire or smoke, repeat Step 1.

SERVICE RECOMMENDATIONS

Fuel System Primary Filter (Water Separator) Element – Replace

SMCS Code: 1263-510-FQ

⚠ WARNING

Personal injury or death may result from failure to adhere to the following procedures:

- Fuel leaked or spilled onto hot surfaces or electrical components can cause a fire.
- Clean up all leaked or spilled fuel. Do not smoke while working on the fuel system.
- Turn the disconnect switch OFF or disconnect the battery when changing fuel filters.

NOTICE

Do not fill the fuel filters with fuel before installing the fuel filters. The fuel will not be filtered and could be contaminated. Contaminated fuel will cause accelerated wear to fuel system parts.

The primary filter/water separator is located behind the access door on the right side of the machine.

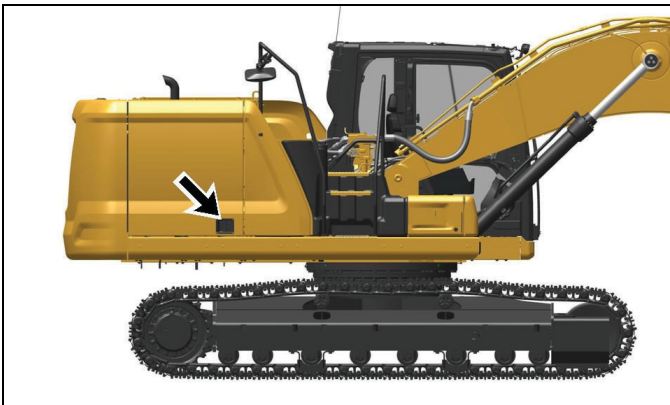
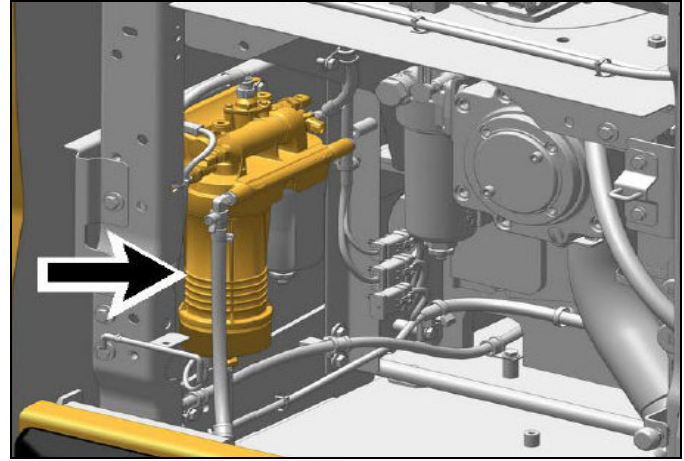

Figure 10-101

g06182545



g06342852

Figure 10-102: Typical Example

1. Open the rear access door on the right side of the machine.

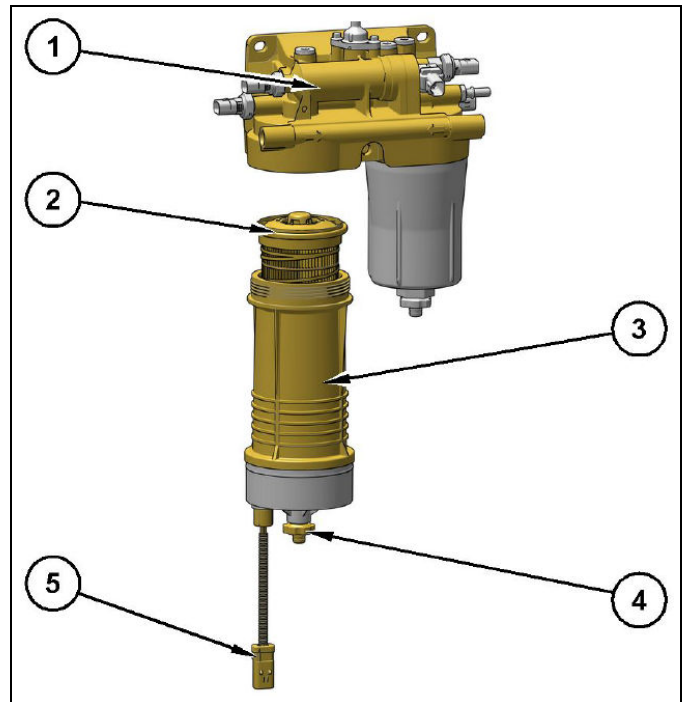

Figure 10-103

g06344343

Typical example of primary filter water separator

- (1) Filter base
- (2) Filter
- (3) Filter housing
- (4) Drain valve
- (5) Sensor

2. Turn drain valve (4) counterclockwise to open. The drain valve is on the bottom of the water separator.

NOTE: Refer to “General Safety*” on page 2-11 for information on Containing Fluid Spillage.

3. Drain the water and the sediment into a suitable container.

NOTE: Dispose of used fluids according to local regulations.

4. Close the drain valve (4).
5. Disconnect the water sensor (5) from the harness.

NOTE: Do not attempt to remove the sediment bowl from the housing. The sediment bowl is permanently attached to the housing. Attempting to remove the sediment bowl may damage the bowl.

6. Unscrew filter housing (3) and remove primary filter (2). A filter wrench may be used to loosen the filter housing. Properly discard the used filter.
7. Clean the mounting base (1).
8. Lubricate the seal of the new filter (2) with clean diesel fuel.
9. Install the new filter (2) into the housing.
10. Tighten the filter housing approximately 1/6 of a turn. Do not use tools to tighten the filter housing to the filter base.
11. Ensure that sensor (5) is in the correct position and connect to the wiring harness. If the sensor was removed from the bowl, install the sensor and tighten to $2.5 \pm 0.5 \text{ N}\cdot\text{m}$ ($22 \pm 4 \text{ lb in}$).
12. Open the fuel shutoff valve.
13. Close the access door.

Fuel System Secondary Filter – Replace*

SMCS Code: 1261-510

S/N: KTN1-10000
S/N: HEX1-10000
S/N: RAZ1-10000

⚠ WARNING

Personal injury or death can result from a fire.

Fuel leaked or spilled onto hot surfaces or electrical components can cause a fire.

Clean up all leaked or spilled fuel. Do not smoke while working on the fuel system.

Turn the disconnect switch OFF or disconnect the battery when changing fuel filters.

NOTICE

Do not fill fuel filters with fuel before installing them. Contaminated fuel will cause accelerated wear to fuel system parts.

NOTICE

Do not allow dirt to enter the fuel system. Thoroughly clean the area around a fuel system component that will be disconnected. Fit a suitable cover over any disconnected fuel system components.



Figure 10-104

g06182545

1. Open access door on the right side of the machine.
2. Shut off the fuel supply. Refer to “Stop the Engine if an Electrical Malfunction Occurs*” on page 7-49I for additional information on the fuel shut off valve.

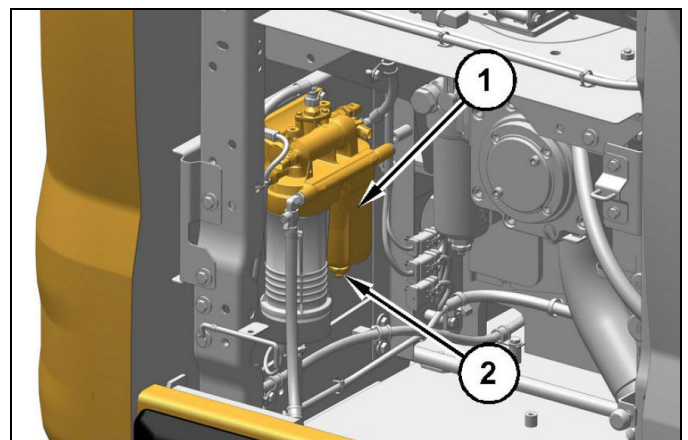

Figure 10-105

g06342848

3. Loosen drain valve (2) and allow the fuel to drain out of the housing into a suitable container.

NOTE: Refer to “General Safety*” on page 2-11 for information on Containing Fluid Spillage.

SERVICE RECOMMENDATIONS

4. After all the fuel has been removed, tighten the drain.
5. Remove the secondary fuel filter housing (1) from the base.
6. Remove the filter element from the housing.
7. Clean the filter housing and the base.
8. Install the new filter element into the housing.
9. Apply a thin coat of clean diesel fuel to the sealing surface of the new fuel filter.
10. Install the new filter and tighten to 50 +/- 5 N·m (36.9 +/- 4 ft lb).
11. Turn on the fuel supply.
12. Close the access door.

Fuel System Water Separator – Drain*

SMCS Code: 1263

NOTICE

 Care must be taken to ensure that fluids are contained during performance of inspection, maintenance, testing, adjusting, and repair of the machine. Be prepared to collect the fluid with suitable containers before opening any compartment or disassembling any component containing fluids.

Contact the CZM After Sales Department for tools and supplies suitable to collect and contain fluids on CZM products.

Dispose of all fluids according to local regulations and mandates.

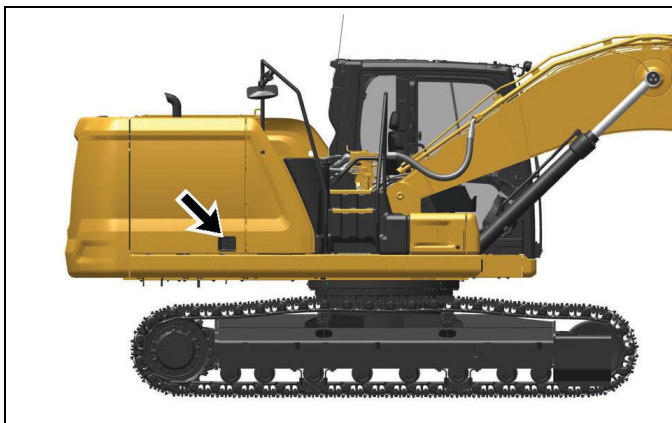

Figure 10-106

g06182545

1. Open the access door on the right side of the machine.

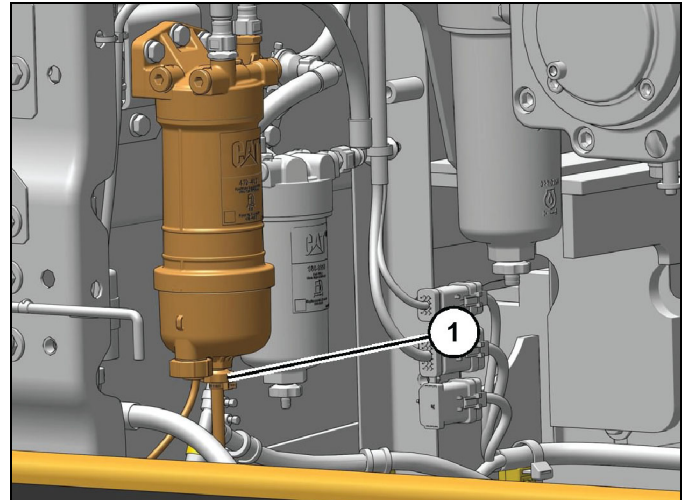

Figure 10-107

g06182984

2. Open drain valve (1) on the bottom of the fuel/water separator element. Drain the water into a suitable container.
3. Close the drain valve when all the water has been drained.

NOTE: When water is not drained from the primary filter sufficiently, water will collect in the secondary fuel filter. Trapped water will eventually overflow. Draining water from the secondary fuel filter will prevent water damaging the fuel system. The procedure for the secondary filter is the same as the primary filter.

4. Close the access door.

Fuel Tank Strainer – Clean*

SMCS Code: 1273-070-STR\

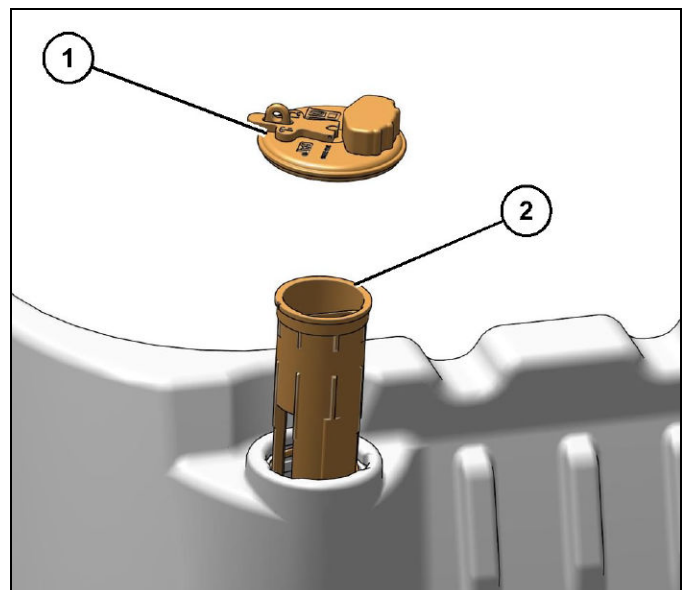

Figure 10-108

g06183008

1. Remove fuel tank cap (1).
2. Remove strainer (2) from the filler opening.
3. Wash the strainer in a clean, nonflammable solvent.
4. Install the strainer into the filler opening.
5. Install the fuel tank cap.

Fuel Tank Water and Sediment – Drain*

SMCS Code: 1273-543

The drain valve for the fuel tank is located in the right compartment.

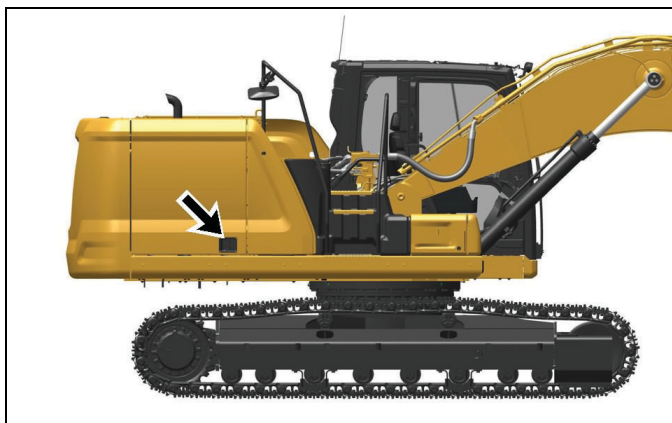

Figure 10-109

g06182545

1. Open the right compartment door.

NOTE: Refer to “General Safety*” on page 2-11 for information on Containing Fluid Spillage.

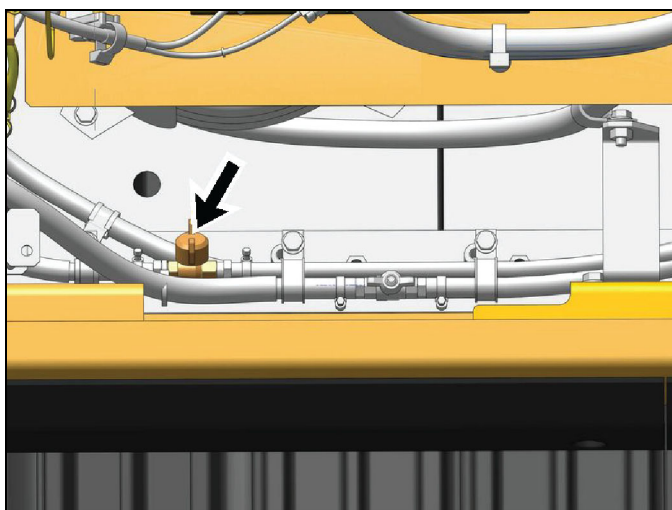

Figure 10-110

g06182139

2. Open the drain valve by turning the valve counterclockwise. Allow the water and the sediment to drain into a suitable container.

NOTE: Dispose of drained fluids according to local regulations.

3. Close the drain valve by turning the valve clockwise.
4. Close the compartment door.

Diesel Exhaust Fluid (DEF)

NOTICE

Ensure that the engine is stopped before any servicing or repair is performed.

NOTICE

Care must be taken to ensure that fluids are contained during performance of inspection, maintenance, testing, adjusting, and repair of the machine. Be prepared to collect the fluid with suitable containers before opening any compartment or disassembling any component containing fluids.

Contact the CZM After Sales Department for tools and supplies suitable to collect and contain fluids on CZM products.

Dispose of all fluids according to local regulations and mandates.

Diesel Exhaust Fluid Filler Screen – Clean*

Emission Related Component

SMCS Code: 108K-070-Z3

The filler neck adapter filter screen in the diesel exhaust fluid tank will need to be cleaned or replaced if contaminated.

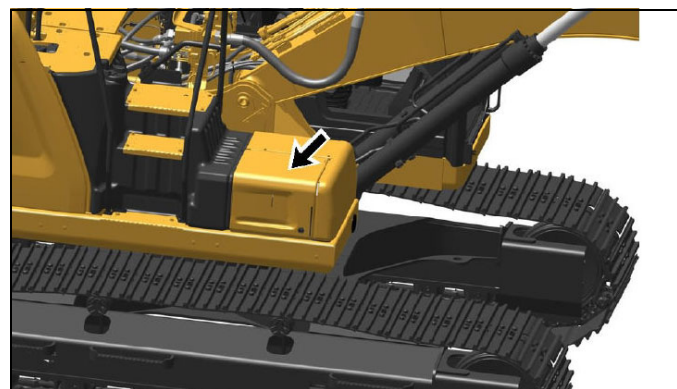

Figure 10-111

g06183098

1. Open the Diesel Exhaust Fluid (DEF) compartment.

SERVICE RECOMMENDATIONS

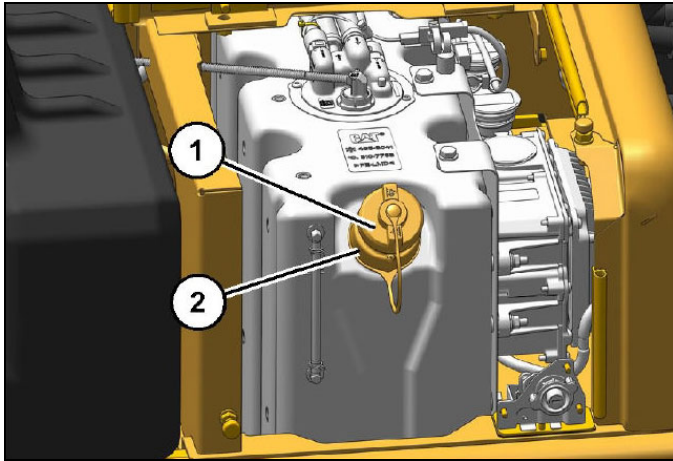

Figure 10-112

g06183119

2. Remove fill cap (1).
3. Use a screwdriver or pick to press the tabs on the strainer. Pull the strainer upward from both sides of fill neck adapter (2).

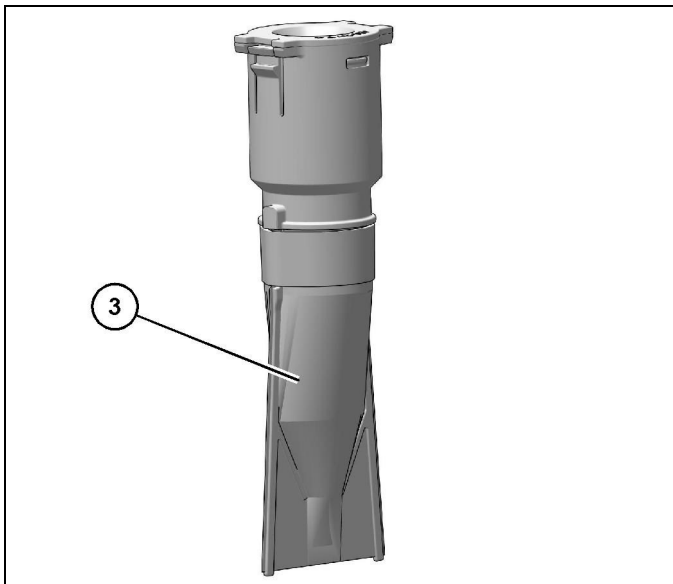

Figure 10-113

g06183125

4. Use water or compressed air to clean out the filter screen (3). If there is any debris inside, dry and remove the debris by turning the screen upside down and dumping debris out. If the debris cannot be removed or if the filter screen is damaged, replace the filter screen.

Diesel Exhaust Fluid Filter Manifold Filters – Replace*

Emission Related Component

SMCS Code: 108K-510-FI

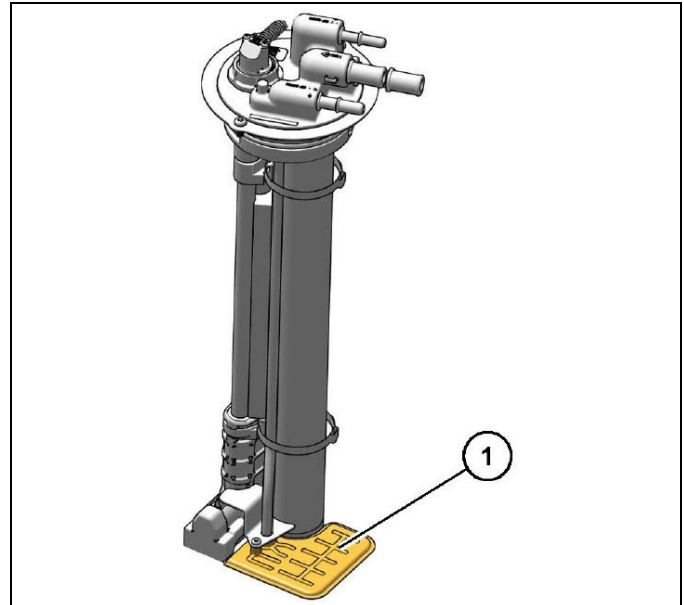

Figure 10-114

g06183110

Replace the manifold filter (1).

Diesel Exhaust Fluid – Drain*

Emission Related Component

SMCS Code: 108K-543

NOTICE

 Care must be taken to ensure that fluids are contained during performance of inspection, maintenance, testing, adjusting, and repair of the machine. Be prepared to collect the fluid with suitable containers before opening any compartment or disassembling any component containing fluids.

Contact the CZM After Sales Department for tools and supplies suitable to collect and contain fluids on CZM products.

Dispose of all fluids according to local regulations and mandates.

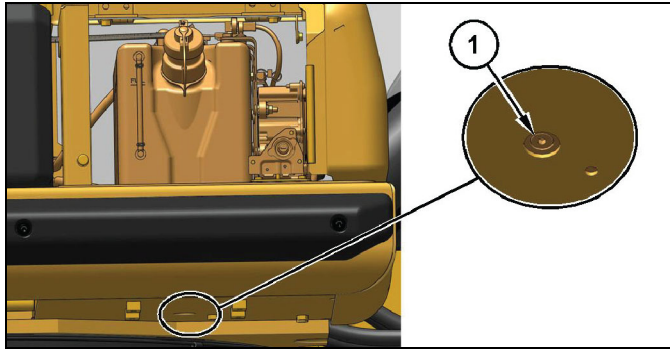

Figure 10-115

g06604316

1. Remove drain plug (1).
2. Drain the diesel exhaust fluid into a suitable container.
3. Install and tighten the plug.

Diesel Exhaust Fluid – Fill*

Emission Related Component

SMCS Code: 108K-544

NOTE: Stop the engine and turn the engine start switch to the OFF position before filling the DEF tank.
Failure to stop the engine may cause fault codes.

Refer to “Drilling Operations” on page 7-40 for more information on the SCR warning system.

NOTICE

Care must be taken to ensure that fluids are contained during performance of inspection, maintenance, testing, adjusting, and repair of the machine. Be prepared to collect the fluid with suitable containers before opening any compartment or disassembling any component containing fluids.

Contact the CZM After Sales Department for tools and supplies suitable to collect and contain fluids on CZM products.

Dispose of all fluids according to local regulations and mandates.

Reference: See Chapter 4, “Technical Specifications” for the capacity of the DEF tank for your machine.

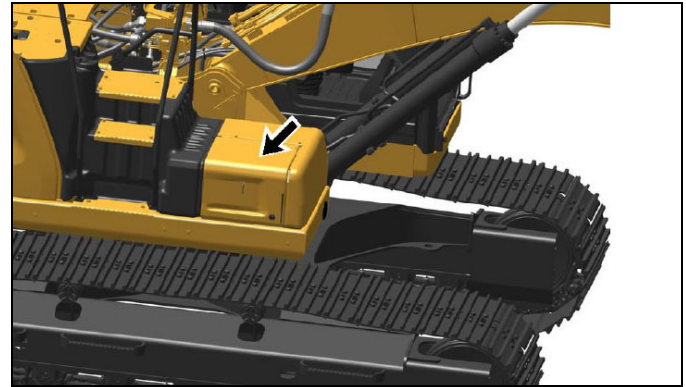

Figure 10-116

g06183098

The DEF tank is located inside the storage box on the right side of the machine.

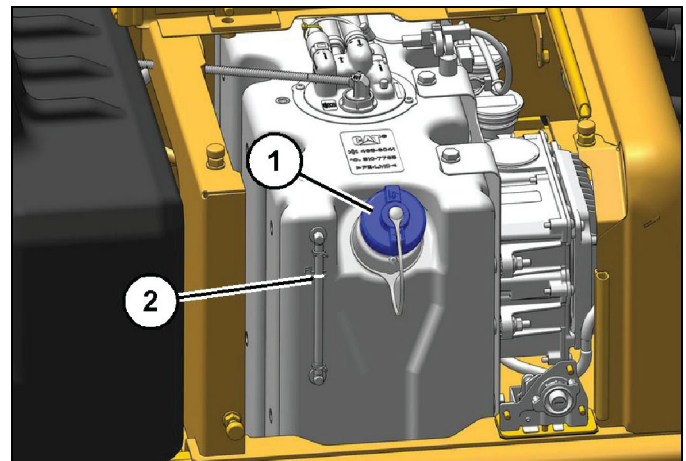

Figure 10-117

g06652823



Figure 10-118: Blue DEF Tank Filler Cap

g06306029

1. Clean the blue DEF tank filler cap and the surrounding area.
2. Remove the blue DEF tank filler cap.
3. Fill the tank with diesel exhaust fluid (DEF). DEF level gauge is located on the front side of DEF tank.

NOTE: Do not fill the DEF tank from a contaminated container or funnel.

SERVICE RECOMMENDATIONS

NOTE: Do not overfill the tank. DEF can freeze and needs room for expansion.

4. Install the blue DEF tank filler cap.

Refer to “Fluids and Lubricants” on page 10-11 for more information on diesel exhaust fluid (DEF) guidelines.

Diesel Exhaust Fluid Filter – Replace*

Emission Related Component

SMCS Code: 108K-510-FI

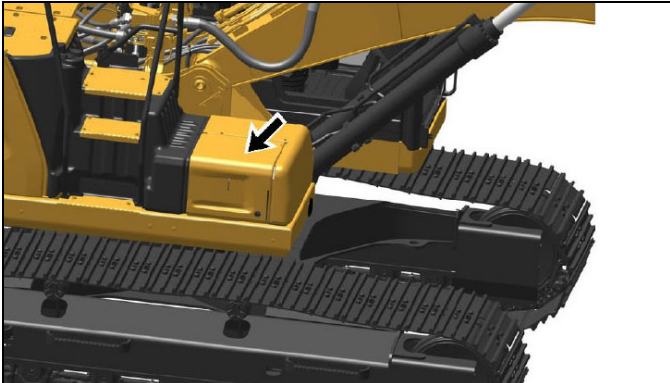

Figure 10-119

g06183098

1. Open the Diesel Exhaust Fluid (DEF) compartment.

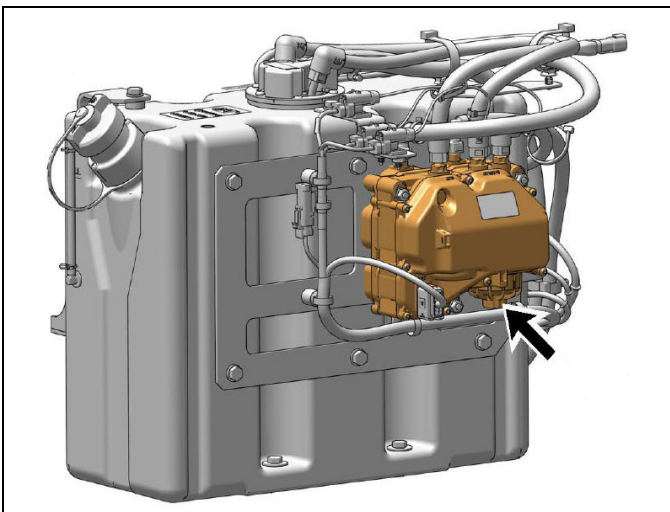

Figure 10-120

g06210724

For clarity, the DEF assembly has been shown removed from the compartment.

2. Ensure that the area around the DEF filter is clean and free from dirt.

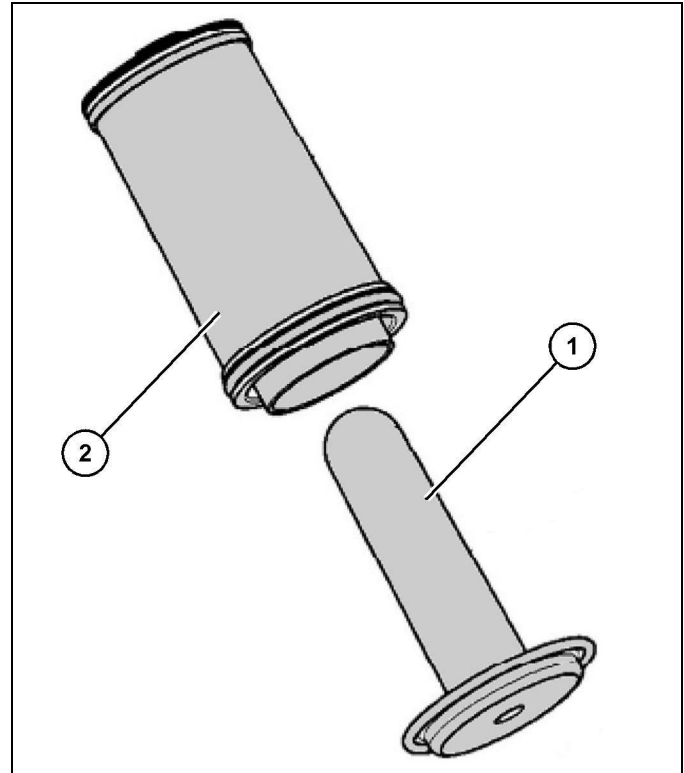

Figure 10-121

g06216533

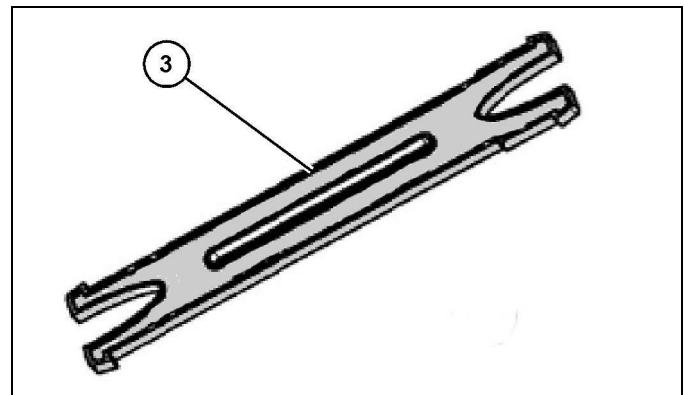

Figure 10-122

g06216531

3. Unscrew the cap, remove expansion device (1) from DEF filter (2). Then, remove the DEF filter using special tool (3) that comes with the new filter. Discard the old filter and expansion device.
4. Install a new DEF filter assembly into the DEF pump housing.
5. Tighten the filter cap to $20 \pm 5 \text{ N}\cdot\text{m}$ ($15 \pm 4 \text{ lb ft}$).
6. Turning on the power will automatically prime the DEF system.

Diesel Exhaust Fluid Injector – Replace*

Emission Related Component

SMCS Code: 108I-510

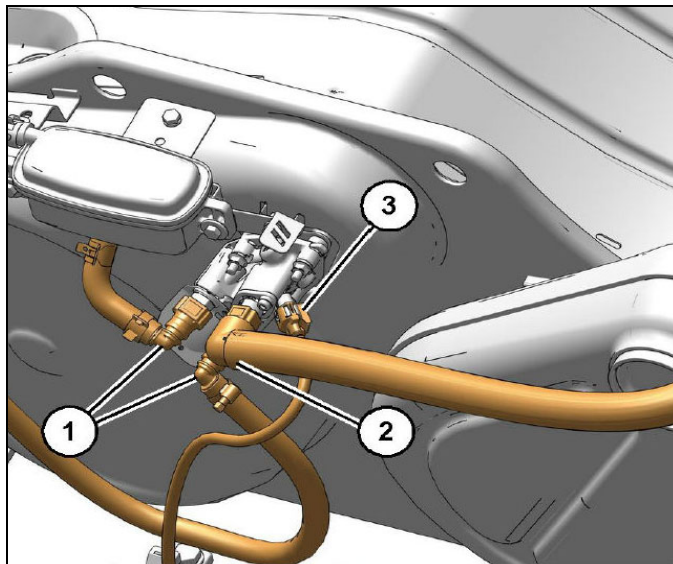

g06226112

Figure 10-123: Typical Example

- (1) Coolant lines
- (2) DEF line
- (3) Electrical connector

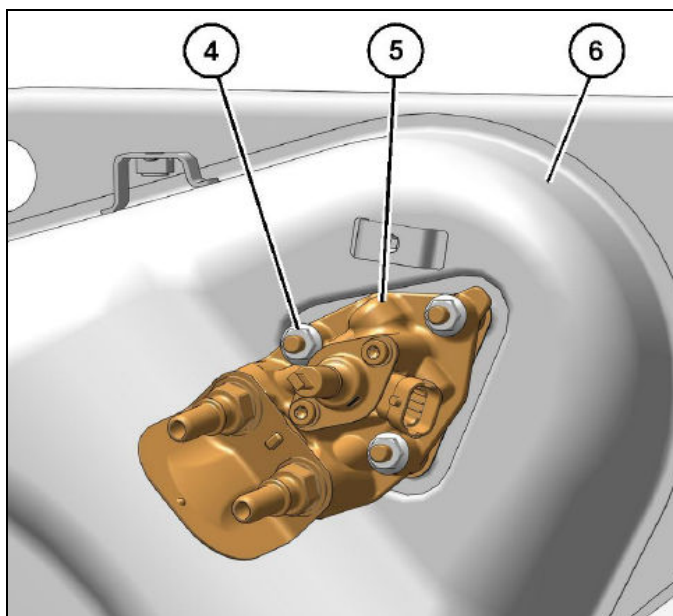

g06226151

Figure 10-124: Typical Example

- (4) Nuts
- (5) DEF injector
- (6) Clean Emission Module

1. Drain the coolant to remove coolant lines (1). Remove cooling lines (1) and remove Diesel Exhaust Fluid (DEF) line (2).
2. Remove electrical connector (3) from DEF injector (5) and install protection caps to DEF injector (5). Remove nuts (4) and washers (9) from DEF injector (5) and remove DEF injector from Clean Emission Module (CEM) (6).

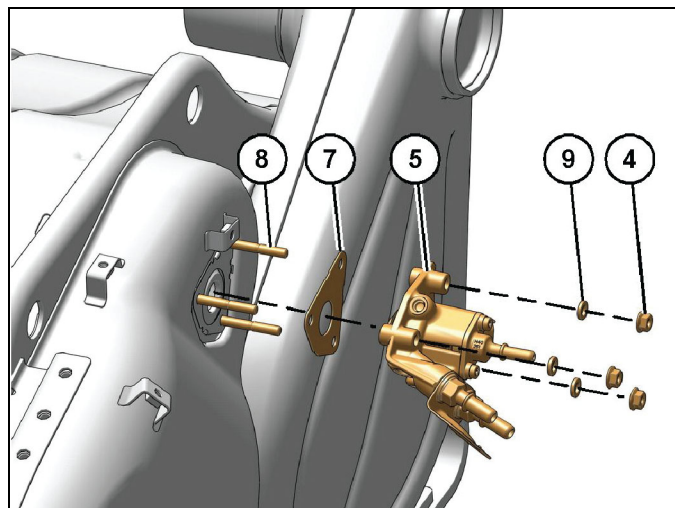

g06226155

Figure 10-125: Typical Example

- (4) Nuts
 - (5) DEF injector
 - (7) Gasket
 - (8) Studs
 - (9) Washers
3. Remove gasket (7) and remove studs (8). Discard the gasket and the studs.
 4. Ensure that the sealing face of the CEM is clean and free from dirt.
 5. Apply bostik pure nickel anti-seize compound to ends of the new studs (8). Install the coated ends of the new studs into the CEM, and tighten to a torque of 5 N•m (44 lb in).
 6. Install new gasket (7), ensure that the metal side of the gasket is to the CEM. Install new DEF injector (5) to CEM (6).
 7. Install washers (9) and apply bostik pure nickel anti-seize compound to the threads of studs (8).
 8. Install nuts (4) and tighten the nuts to a torque of 5 N•m (44 lb in). Retighten the nuts to 5 N•m (44 lb in). Then, turn the nuts an additional 90 degrees.
 9. Install electrical connector (3), DEF line (2), and coolant lines (1).
 10. Fill cooling system to the correct level. Ensure that the correct specification of coolant is used.

SERVICE RECOMMENDATIONS

If available, using the electronic service tool (ET) perform DEF Dosing System Verification test.

Hydraulic System

Release of Hydraulic Pressure from the Main Hydraulic System*

⚠ WARNING

Personal injury can result from hydraulic oil pressure and hot oil.

Hydraulic oil pressure can remain in the hydraulic system after the engine has been stopped. Serious injury can be caused if this pressure is not released before any service is done on the hydraulic system.

Make sure all of the attachments have been lowered, oil is cool before removing any components or lines. Remove the oil filler cap only when the engine is stopped, and the filler cap is cool enough to touch with your bare hand.

NOTICE

 Care must be taken to ensure that fluids are contained during performance of inspection, maintenance, testing, adjusting, and repair of the machine. Be prepared to collect the fluid with suitable containers before opening any compartment or disassembling any component containing fluids.

Contact the CZM After Sales Department for tools and supplies suitable to collect and contain fluids on CZM products.

Dispose of all fluids according to local regulations and mandates.

Perform the following steps to release the hydraulic system pressure from the main hydraulic system.

NOTE: *For additional safety, wrap hydraulic joint with material that could absorb/reduce any residual pressure of oil when released. Loosen the joint slowly, pause, and carefully check hydraulic joint for tensions indicating presence of pressure or spring force in lines or components.*

1. Position the machine on level ground.
2. Position the mast in a vertical (operating) position. Lower the rotary to its lowest position on the mast. Lower the work tool or kelly bar to the ground.
3. Release the system pressure from the drilling rig and swing hydraulic circuits.

NOTE: Perform Step 3b through Step 3d immediately after the engine is shut off to insure adequate pilot system pressure is available to release the pressure in the hydraulic circuits.

- a. Shut off the engine.
- b. Turn the engine start switch to the ON position without starting the engine.
- c. Place the hydraulic activation control lever in the UNLOCKED position.

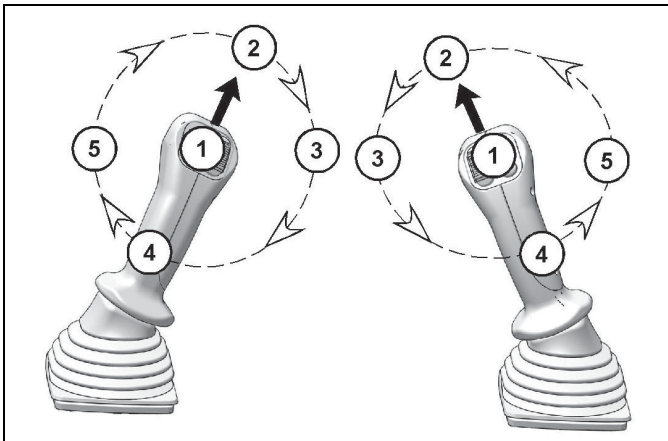

Figure 10-126

g06184822

- d. Move both joysticks in a circular motion to the FULL STROKE positions multiple times until the pilot accumulator has been exhausted.

NOTE: Pilot pressure is required to relieve hydraulic system pressure.

- e. Place the hydraulic activation control lever in the LOCKED position.
- f. Start the engine to recharge the pilot accumulator.

NOTE: Do not activate any controls when recharging the pilot accumulator.

- g. Shut off the engine.
- h. Repeat Step 3b through Step 3g until the high pressure lines have been released.
- i. Repeat steps to relieve pressure in the drilling controls.

NOTE: Each time the accumulator is recharged, start the joysticks at different positions or rotate in the reverse direction. Doing so will ensure that the same circuit is not being relieved each time.

NOTE: You can also move only the joysticks or pedals of the hydraulic circuit that requires service to the full stroke positions after moving joysticks in a circular motion multiple times. This action will release the high pressure only in that single hydraulic circuit. This action will also release any pressure that might be present in the pilot hydraulic circuit.

Hydraulic System Oil – Drain*

⚠ WARNING

Hot oil and hot components can cause personal injury. Do not allow hot oil or hot components to contact skin.

NOTICE

🌿 Care must be taken to ensure that fluids are contained during performance of inspection, maintenance, testing, adjusting, and repair of the machine. Be prepared to collect the fluid with suitable containers before opening any compartment or disassembling any component containing fluids.

Contact the CZM After Sales Department for tools and supplies suitable to collect and contain fluids on CZM products.

Dispose of all fluids according to local regulations and mandates.

1. Park the machine on level ground.
2. Lower the rotary. Lower the Kelly bar and any tooling to the ground.
3. Stop the engine.

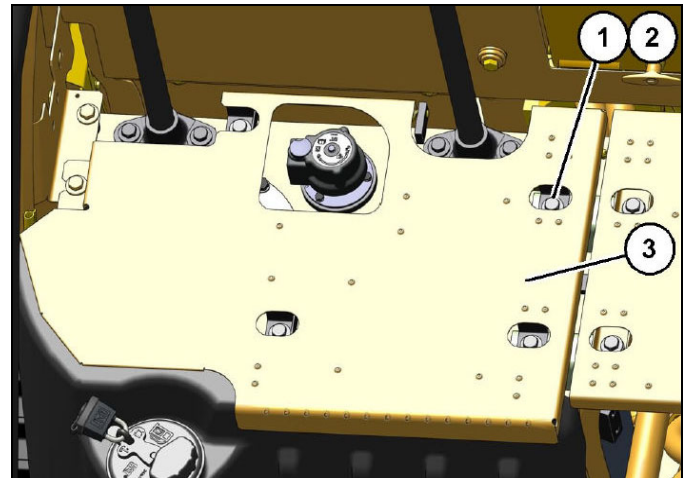

Figure 10-127

g06182169

4. Remove five bolts (1) and washers (2). Remove cover (3) from the top of the hydraulic tank.

SERVICE RECOMMENDATIONS

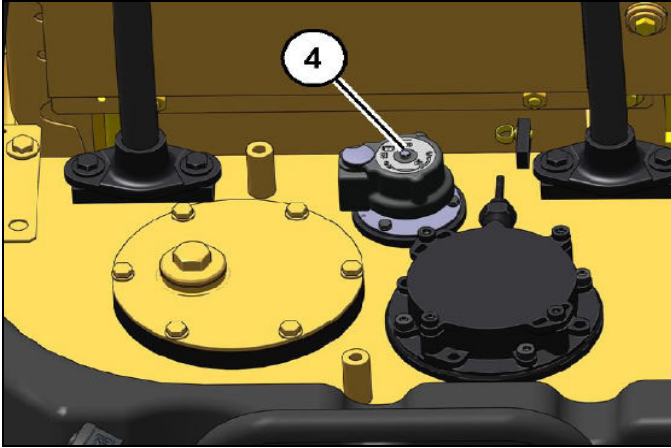
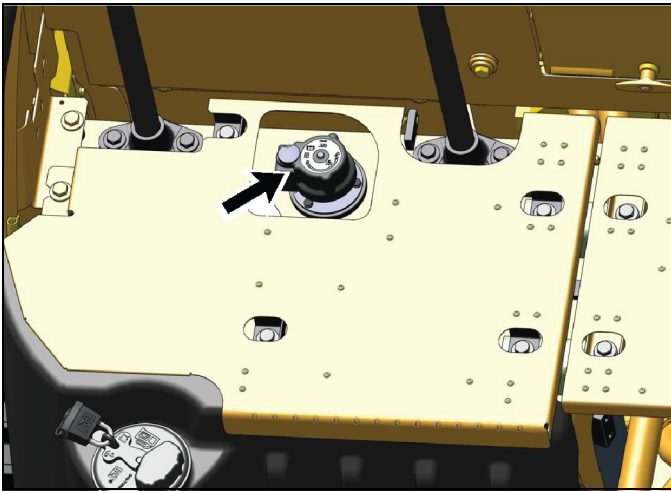

Figure 10-128

g06182174

5. Clean the area thoroughly to keep dirt out of the screen cover and filler cap (4).



g06184080

Figure 10-129: Hydraulic Tank Filler Cap Location

⚠ WARNING

Pressurized system!

The hydraulic tank contains hot oil under pressure. To prevent burns from the sudden release of hot oil, relieve the tank pressure with the engine off. Relieve pressure by slowly turning the cap until the cap reaches the secondary stop.

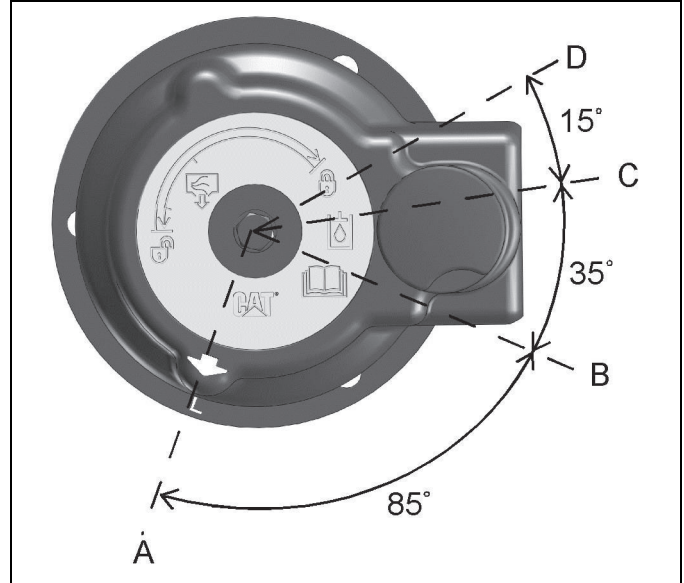

g06184990

Figure 10-130: Filler Cap

- (A) LOCK position
 - (B) PRESSURE RELEASE - START position
 - (C) PRESSURE RELEASE - END position
 - (D) OPEN position
6. Release the pressure that may be present in the return hydraulic circuit with the following procedure. Refer to Figure 10-130 for filler cap positions.
 - a. Turn the filler cap counterclockwise and move the arrow from position (A) to position (B).
 - b. Release the pressure for a minimum of 45 seconds by moving the arrow from position (B) to position (C).
 - c. Move the arrow from position (C) to position (D).
 - d. After the tank pressure is relieved, tighten the filler cap.

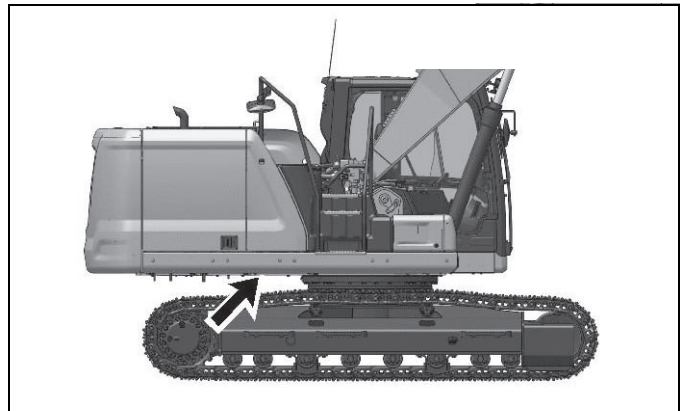

g06182179

Figure 10-131: Access Cover Location

7. Remove the hydraulic tank access cover that is located under the upper structure. Removing the cover will allow access to the drain valve.

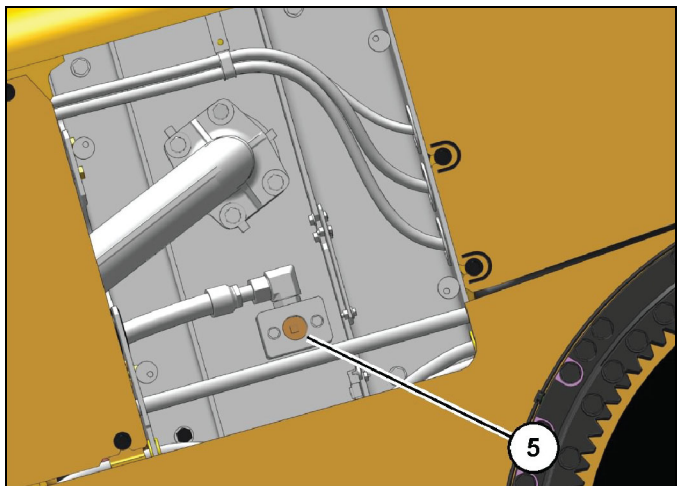

Figure 10-132

(5) Plug

NOTE: Refer to “General Safety*” on page 2-11 for information on Containing Fluid Spillage.

8. Remove plug (5).
9. Inspect the O-ring. Replace the O-ring if wear or damage is evident.

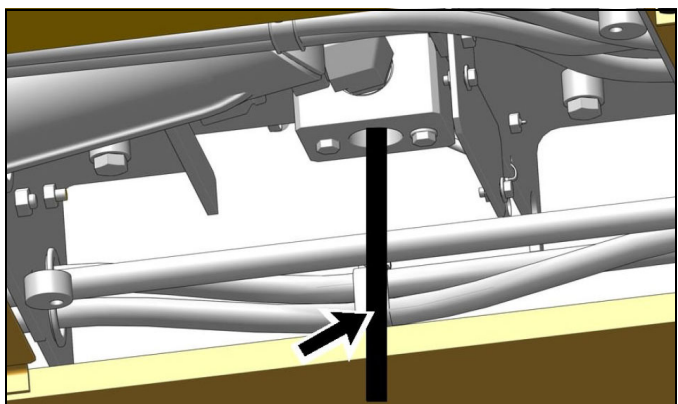

Figure 10-133

10. Use a bar to push the plunger up to allow the oil to drain.
 11. Drain the oil into a suitable container.
- NOTE:** Dispose of used fluids according to local regulations.
12. After the oil has been drained, clean drain plug (5) and install. Tighten the plug to $68 \pm 7 \text{ N}\cdot\text{m}$ ($50 \pm 5 \text{ lb}\cdot\text{ft}$).
 13. Open the access door on the right side of the machine.
 14. Clean the pump, the hydraulic lines, and the hydraulic tank.

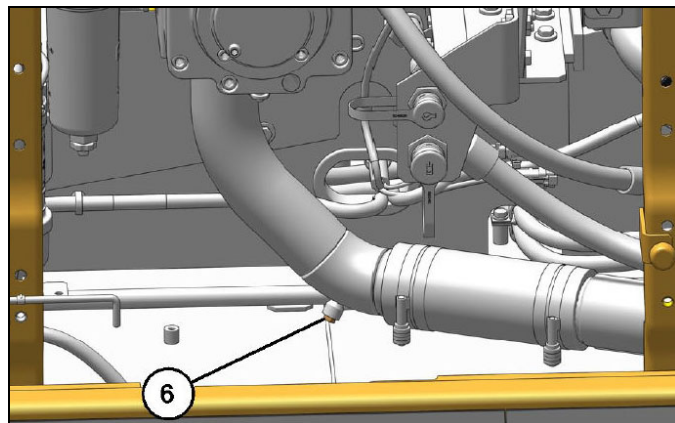

Figure 10-134

15. Remove plug (6) from the tube. Allow the oil to drain into a container.
16. Inspect the O-ring. Replace the O-ring if wear or damage is evident.
17. Clean the plug. Install the plug and the O-ring into the drain port.

Hydraulic Tank Screen – Clean*

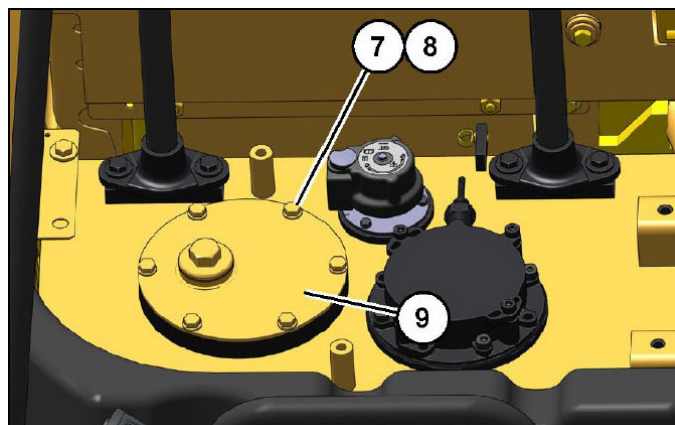

Figure 10-135

- (7) Bolts
 (8) Washers
 (9) Cover
1. Remove bolts (7), washers (8), and cover (9).

SERVICE RECOMMENDATIONS

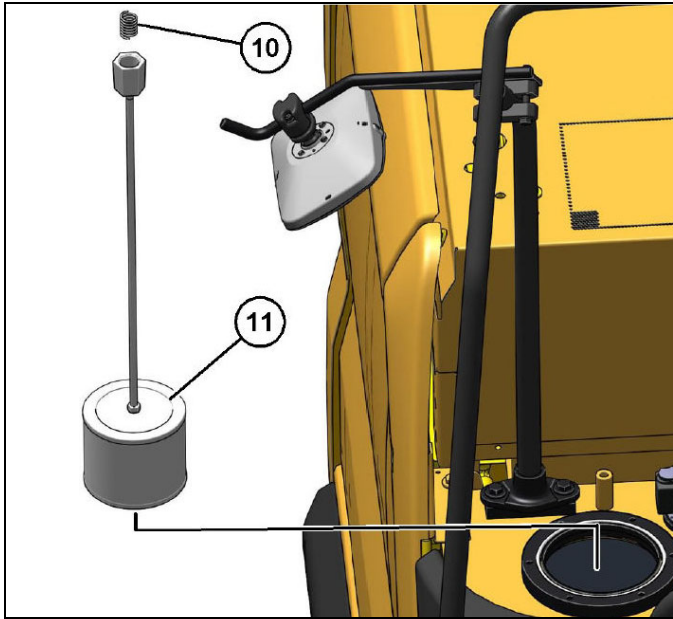

Figure 10-136

g06182213

- (10) Spring
- (11) Screen

2. Remove spring (10) and screen (11).

NOTE: Do not allow spring (10) to fall back into the tank.

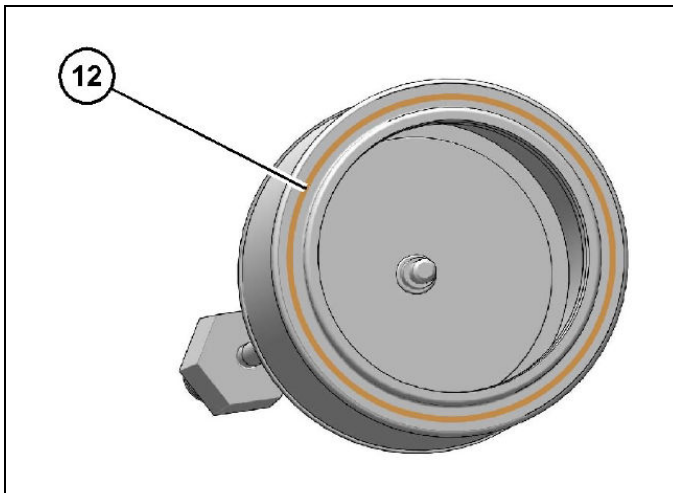

Figure 10-137

g06182515

- (12) O-ring seal

3. Remove O-ring seal (12) from the screen.

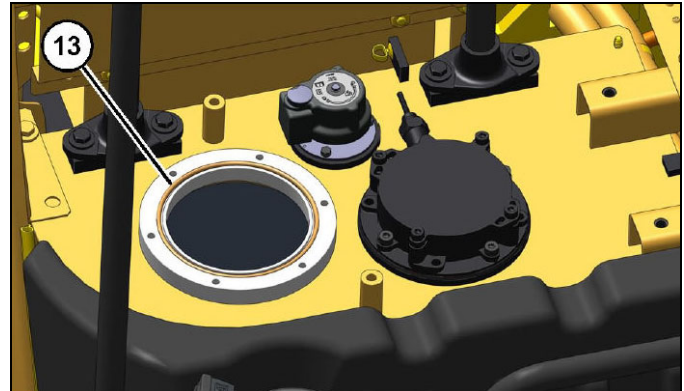

Figure 10-138

g06182229

(13) O-ring seal

4. Remove O-ring seal (13) from the tank.
5. Inspect O-ring seals (12) and (13). Replace the O-ring seals if wear or damage is evident.
6. Wash the screen in a clean nonflammable solvent. Allow the screen to dry. Inspect the screen. Replace the screen, if the screen is damaged.
7. Install O-ring seal (12) on screen (11).
8. Install screen (11) and spring (10). Then install cover (9), washers (8), and bolts (7).

NOTE: Make sure that the O-ring seals and the spring are properly positioned during installation.

Case Drain Filter – Clean*

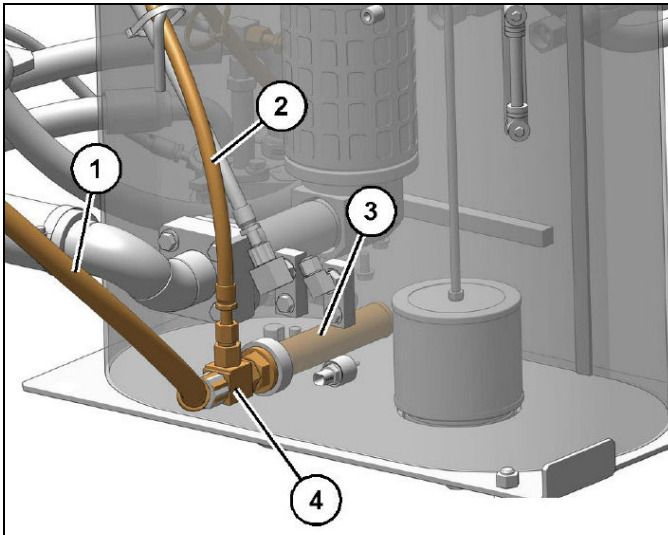

Figure 10-139

g06220559

- (1) Hose
- (2) Hose
- (3) Case drain filter
- (4) Tee

1. Remove hose (1) and hose (2) from tee (4). Remove tee (4).
2. Remove case drain filter (3) from the hydraulic tank.
3. Wash the screen of the case drain filter in a clean nonflammable solvent. Allow the filter to dry. Inspect the filter. Replace the filter if the filter is damaged.
4. Inspect the O-ring seal on the filter. Replace the O-ring seal if wear or damage is evident.
5. Install the filter in the hydraulic tank. Tighten the filter to $175 \pm 26 \text{ N}\cdot\text{m}$ ($129 \pm 19 \text{ lb ft}$).
6. Install the tee onto the filter. Tighten the tee to $65 \pm 10 \text{ N}\cdot\text{m}$ ($48 \pm 7 \text{ lb ft}$).
7. Install the two hoses onto the tee.

Hydraulic System Oil – Fill and Purge Air

1. Park the machine on a level surface.

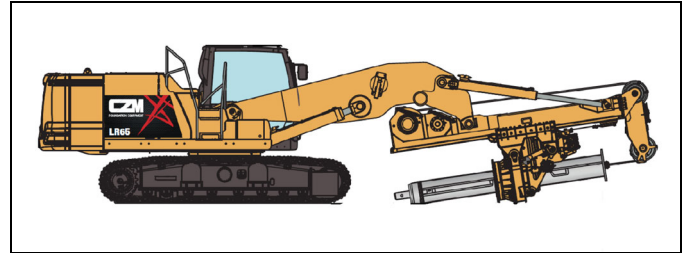

Figure 10-140

0000872

2. Position the machine in the transport position, with the rotary high (rotary crowd cylinder retracted), mast lowered, boom lowered, and undercarriage retracted.
3. Stop the engine.
4. Access the hydraulic pump. The hydraulic pump is located behind the right access door.

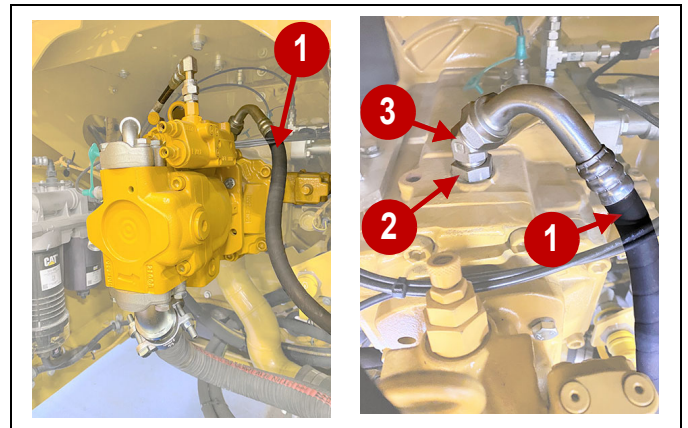

Figure 10-141

0000864/0000865

5. Remove the hose (1) and connectors (2),(3) from the top of the main hydraulic pump.

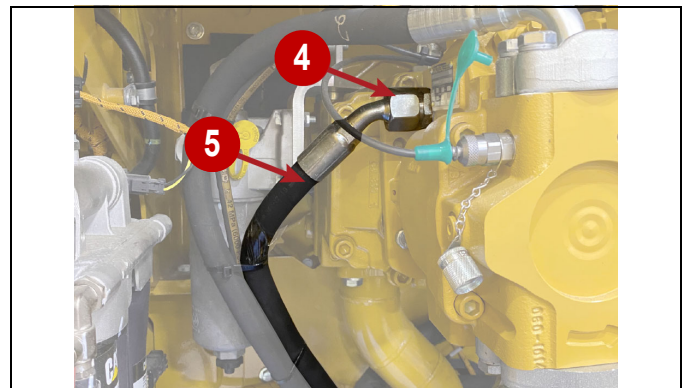

Figure 10-142

0000866

6. Remove the connector (4), and the hose (5) from the auxiliary pump.
7. Remove the hydraulic oil filler cap.

SERVICE RECOMMENDATIONS

- Fill the hydraulic system oil tank to a marked level on the oil sight glass:

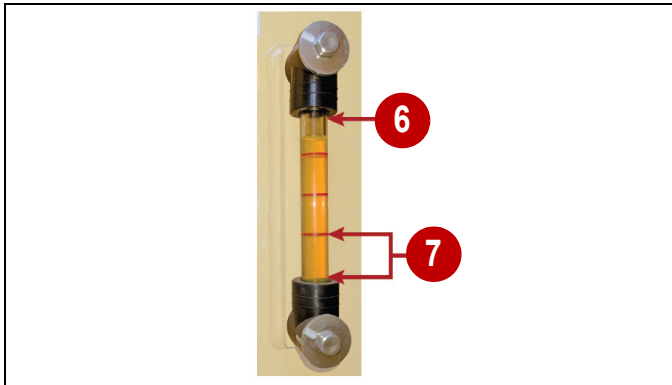

Figure 10-143

0000867

- Transport Level 7) Operational Range
- Maintain the proper level depending on the current oil temperature:
 - If the hydraulic oil temperature is between 87°–121°F (31°–49° C), maintain the oil level within the lower half of the operational range (7).
 - If the hydraulic oil temperature is between 122°–187°F (50°–80° C), maintain the oil level within the upper half of the operational range (7).
 - For temperatures between 50°–86°F (10°–30° C), maintain the oil level slightly above the lower limit.
- Inspect the O-ring seal on the filler cap for damage. Replace O-ring, if necessary.
- Clean the filler cap. Install the filler cap on the hydraulic tank.
- Add hydraulic oil through the opening of the main hydraulic pump until it is full. Do the same for the auxiliary pump.
- Check the condition of the seals. If a seal is damaged, replace the seal.
- After the pumps have been filled with oil, install the drain hoses (1) and (5), connectors (2), (3), and (4) to their original locations.
- Start and run the engine at idle for 5 minutes.

⚠ CAUTION

Pay attention to any unexpected noises coming from the pump, they may indicate cavitation. If noise is heard, shut off the engine immediately and perform the following steps.

- Turn off the engine.

- Slowly loosen hose (1) and (5) until hydraulic oil flows from the connections. Oil (no bubbles) flowing from the connection indicates that the air has been released from the pump.
- Tighten hoses (1) and (5).
- Idle the engine for 5 minutes.

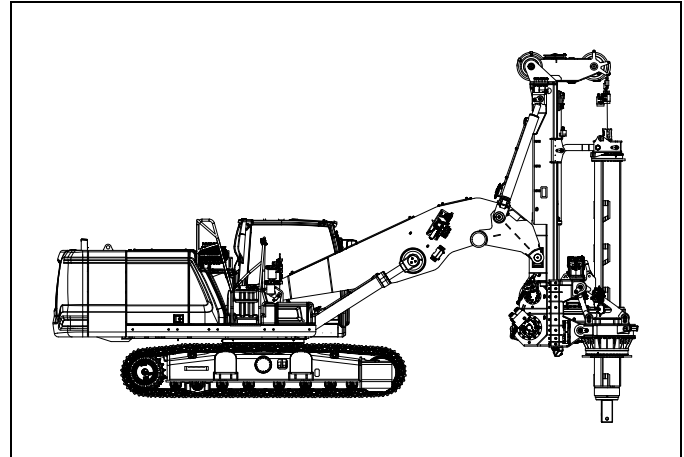

Figure 10-144

0000889

- Raise the mast until it is vertical, place boom at a half stroke, extend the undercarriage, fully lower the rotary, reposition the kelly bar, and remove the work tool as needed.
 - Stop the engine.
 - Check the hydraulic oil level.
- Reference:** For the correct procedure, refer to “Hydraulic System Oil Level – Check*” on page 10-74.
- Close the access door.
- Close the engine hood and latch the engine hood.

Hydraulic System Oil Filter (Return) – Replace*

SMCS Code: 5068-510-RJ

⚠ WARNING

Hot oil and hot components can cause personal injury. Do not allow hot oil or hot components to contact skin.

The return filter is a cartridge type filter. The amount of foreign material that enters the hydraulic system is reduced when the filter element is replaced.

NOTE: If the message display shows that the hydraulic return filter is plugged, turn off the machine. After you make sure that the warning has disappeared, start the machine and run the machine on level ground for approximately 10 minutes. If the warning still appears in the message display, inspect the filter and replace the filter, if necessary.

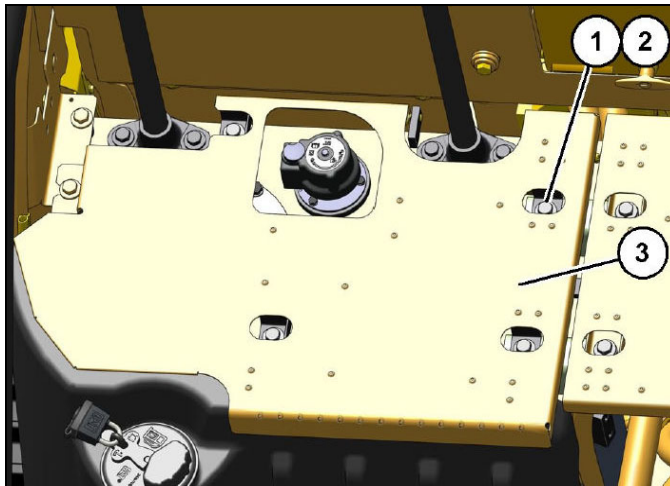

Figure 10-145

1. Remove five bolts (1) and washers (2).
2. Remove cover (3) from the top of the hydraulic tank.
3. Clean the area thoroughly to keep dirt out of the return filter and filler cap.

⚠ WARNING

Pressurized system!

The hydraulic tank contains hot oil under pressure. To prevent burns from the sudden release of hot oil, relieve the tank pressure with the engine off. Relieve pressure by slowly turning the cap until the cap reaches the secondary stop.

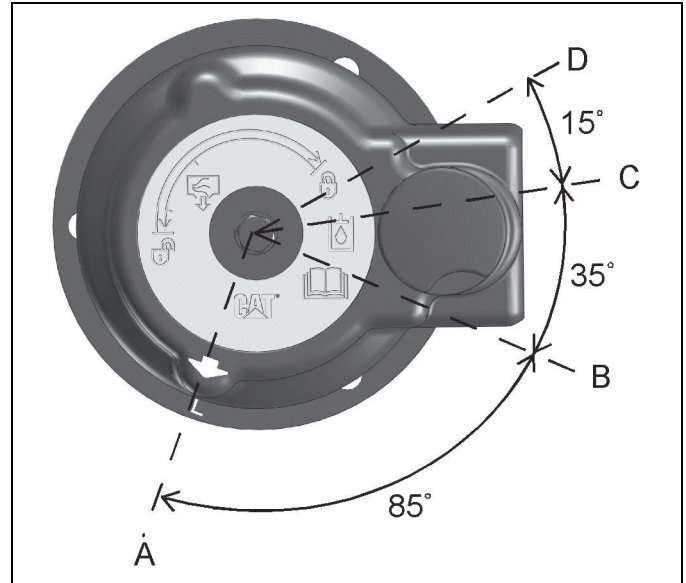

Figure 10-146: Filler Cap

- (A) LOCK position
 - (B) PRESSURE RELEASE - START position
 - (C) PRESSURE RELEASE - END position
 - (D) OPEN position
4. Release the pressure that may be present in the return hydraulic circuit with the following procedure. Refer to Figure 10-146 for filler cap positions.
 - a. Turn the filler cap counterclockwise and move the arrow from position (A) to position (B).
 - b. Release the pressure for a minimum of 45 seconds by moving the arrow from position (B) to position (C).
 - c. Move the arrow from position (C) to position (D).
 - d. After the tank pressure is relieved, tighten the filler cap on the hydraulic tank to position (A).
 5. Check the hydraulic system oil level.

Reference: For the correct procedure, refer to “Hydraulic System Oil Level – Check*” on page 10-74.

SERVICE RECOMMENDATIONS

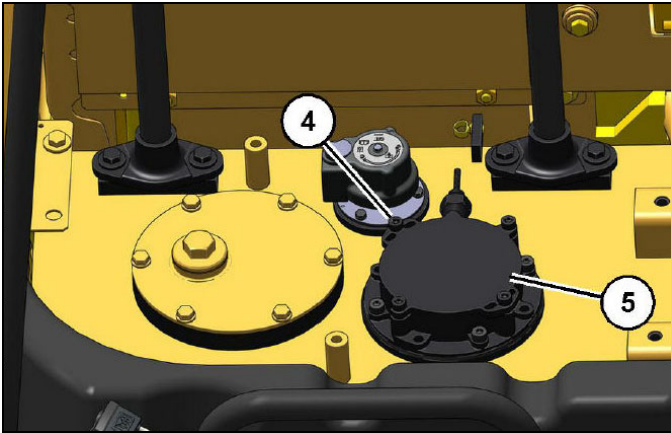

Figure 10-147

g06254537

6. Remove four bolts (4), disconnect the harness connector from the filter bypass switch, and remove cover assembly (5) from the tank. Inspect the O-ring on the cover for damage and replace as necessary.

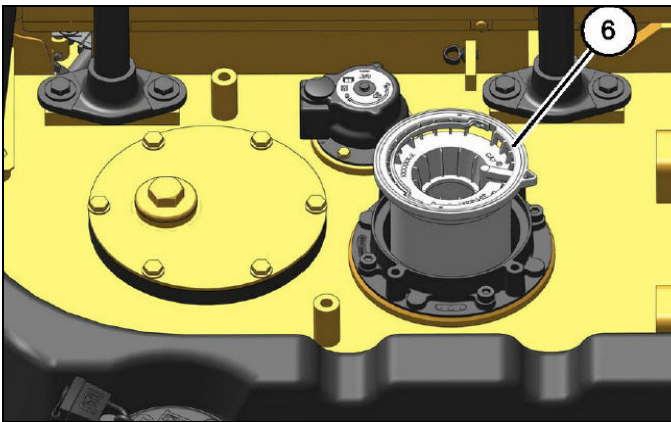

Figure 10-148

g06254829

7. Remove filter element (6) and discard. Install a new element into the filter case.

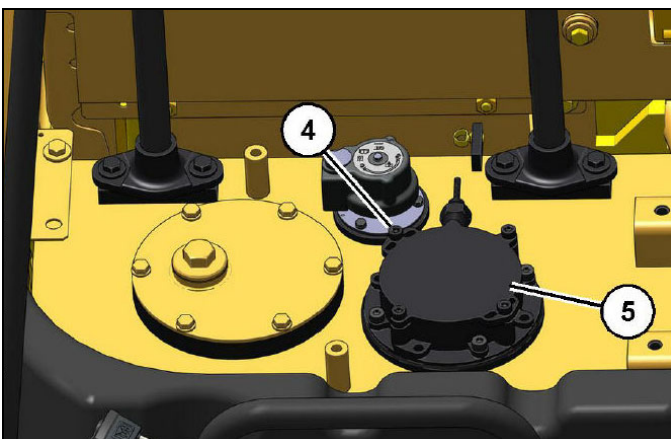

Figure 10-149

g06254537

8. Place cover assembly (5) into position in the tank. Install four bolts (4) and tighten to 30 ± 7 N·m (22 ± 5 lb-ft). Install the harness connector on the filter bypass switch.

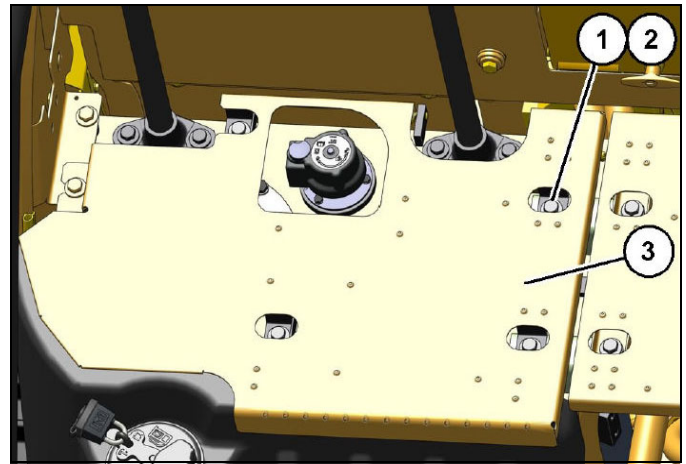

Figure 10-150

g06182169

9. Position cover (3) in place on the top of the hydraulic tank.
10. Install five bolts (1) and washers (2).

Hydraulic System Oil Level – Check*

SMCS Code: 5050-535

WARNING

Hot oil and hot components can cause personal injury. Do not allow hot oil or hot components to contact skin.

NOTICE

Never remove the fill/vent plug from the hydraulic tank if the oil is hot. Air can enter the system and cause pump damage.

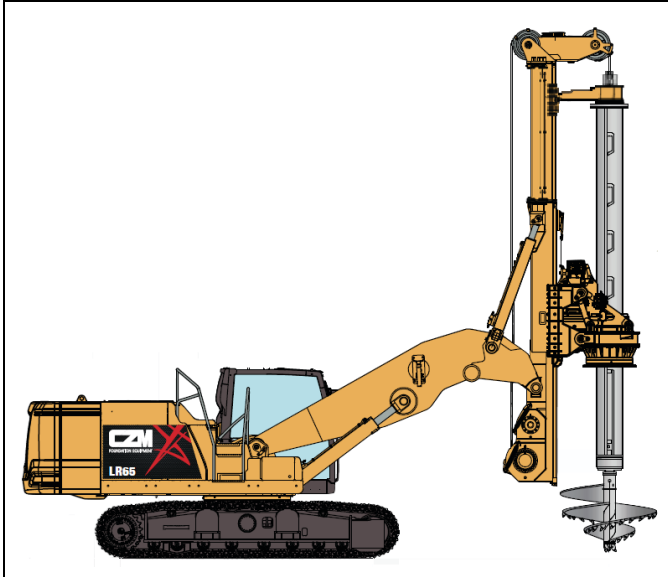

Figure 10-151

00008980

1. Park the machine on level ground.
2. Lower the rotary and position the Kelly bar and any attached tooling to the ground.



Figure 10-152

g06182545

- Open the access door on the right side of the machine.

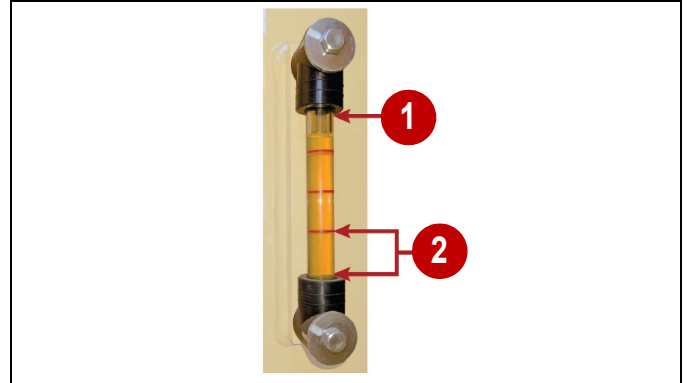

Figure 10-153

0000867

- 1) Transport Level
- 2) Operational Range
3. Maintain the proper level depending on the current oil temperature:
 - If the hydraulic oil temperature is between 87°–121°F (31°–49° C), maintain the oil level within the lower half of the operational range (2).
 - If the hydraulic oil temperature is between 122°–187°F (50°–80° C), maintain the oil level within the upper half of the operational range (2).
 - For temperatures between 50°–86°F (10°–30° C), maintain the oil level slightly above the lower limit.
4. Close the access door.

NOTE: Perform Step 6 through Step 9 if the oil level is low.

NOTE: Refer to “General Safety*” on page 2-11 for information on Containing Fluid Spillage.

⚠ WARNING

Pressurized system!

The hydraulic tank contains hot oil under pressure. To prevent burns from the sudden release of hot oil, relieve the tank pressure with the engine off. Relieve pressure by slowly turning the cap until the cap reaches the secondary stop.

SERVICE RECOMMENDATIONS

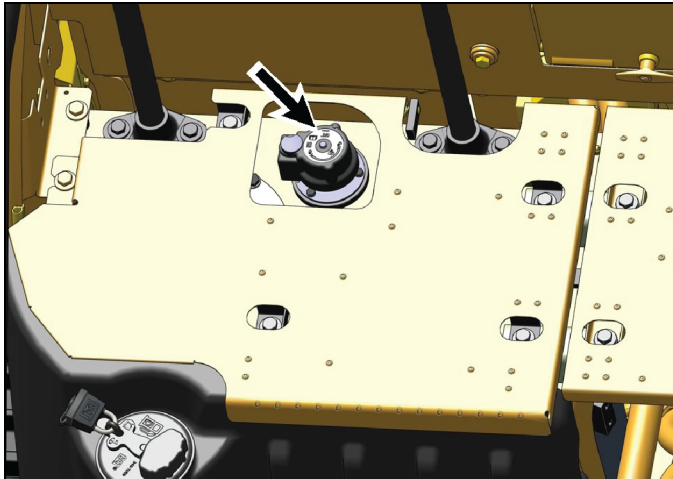

Figure 10-154

g06182653

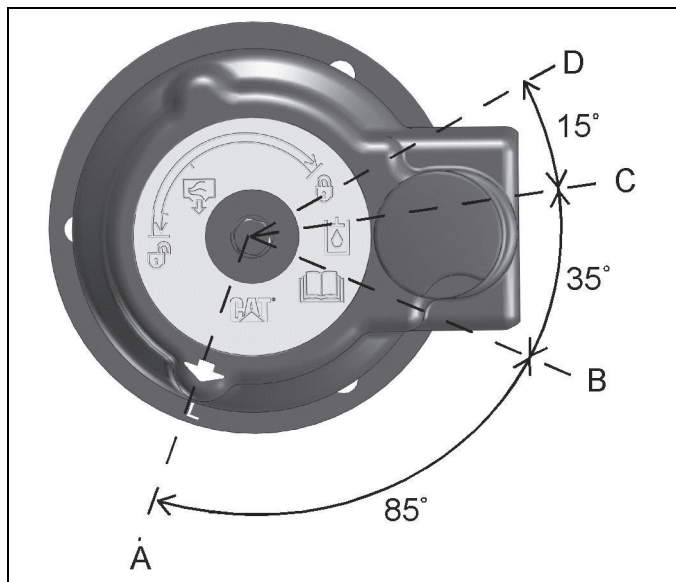

Figure 10-155: Filler Cap

g06184990

- (A) LOCK position
 - (B) PRESSURE RELEASE - START position
 - (C) PRESSURE RELEASE - END position
 - (D) OPEN position
5. Release the pressure that may be present in the return hydraulic circuit with the following procedure. Refer to Figure 10-155 for filler cap positions.
 - a. Turn the filler cap counterclockwise and move the arrow from position (A) to position (B).
 - b. Release the pressure for a minimum of 45 seconds by moving the arrow from position (B) to position (C).
 - c. Move the arrow from position (C) to position (D).
 - d. After the tank pressure is relieved, remove the filler cap.

6. Add oil if necessary. See “Fluids and Lubricants” on page 10-11.
7. Check the O-ring seal on the filler cap. Replace the O-ring seal if the seal is damaged.
8. Clean the filler cap and install on the tank. Tighten the filler cap on the hydraulic tank to position (A).

Hydraulic System Oil Sample – Obtain*

SMCS Code: 5050-008-OC; 5095-008; 5095-SM; 7542-008; 7542

NOTE: If some types of hydraulic oils are used, the hydraulic oil change interval is extended to 6000 hours. Some services after 3,000 hours are still strongly recommended. Contact CZM After Sales Department for details.

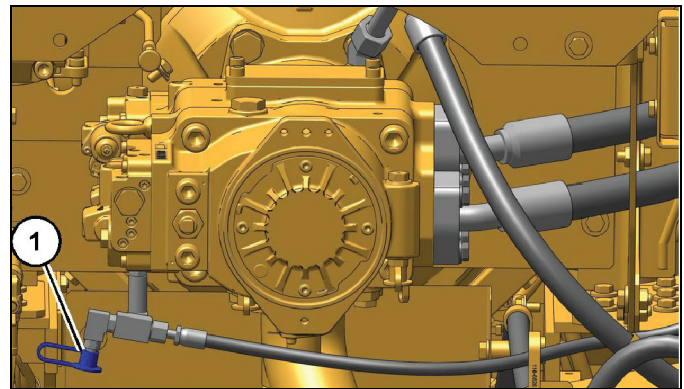

Figure 10-156

g06373208

The hydraulic oil sampling valve (1) is connected to the pilot line of the main hydraulic pump regulator. Obtain a sample of the hydraulic oil from the hydraulic oil sampling valve.

Contact the CZM After Sales Department for more information about obtaining a sample of the hydraulic oil.

Indicators and Gauges – Test*

SMCS Code: 7450-081; 7490-081

Look for broken lenses on the gauges, broken indicator lights, broken switches, and other broken components in the cab.

1. Start the engine.
2. Look for inoperative gauges.
3. Turn on all machine lights. Check for proper operation.
4. Move the machine forward. Release the travel levers and the travel pedals. The machine should stop.
5. Stop the engine.
6. Make any repairs that are required before operating the machine.

Oil Filter – Inspect*

Inspect a Used Filter for Debris*

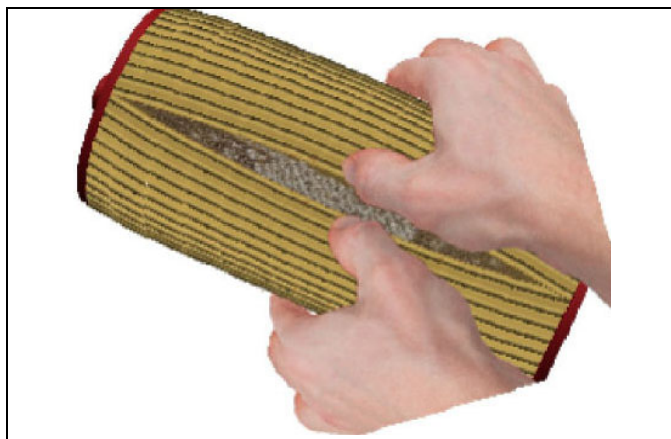

g06224663

Figure 10-157: Hydraulic Oil Filter Inspection

The element is shown with debris.

Use a filter cutter to cut the filter element open. Spread apart the pleats and inspect the element for metal and for other debris. An excessive amount of debris in the filter element can indicate a possible failure.

Return Line Filter Replacement

The drain line filters are screw on, low pressure filters for the drilling components. The filter contains a bypass valve that bypasses oil filtration when the filter becomes blocked.

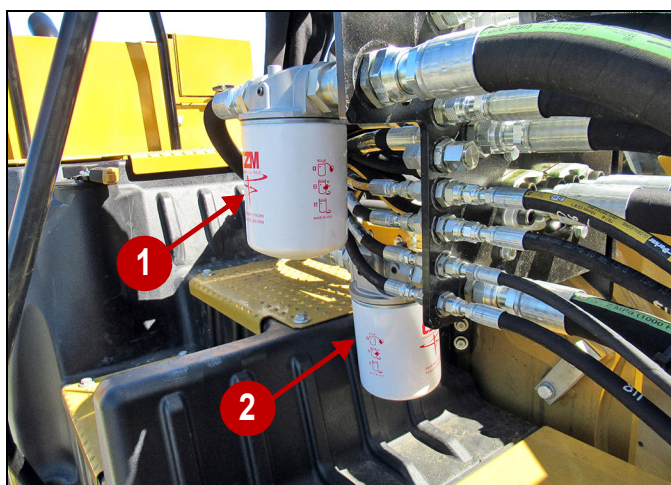

00000327

Figure 10-158

- | | |
|--------------------------------------|---|
| 1) Return Filter –
Rotary Gearbox | 2) Return Filter – Motors (Rotary,
Main/Auxiliary Winches) |
|--------------------------------------|---|

Replacing the Return Filter Elements

1. Prepare the machine for service. See “Prepare the Machine for Maintenance*” on page 10-5.
2. Clean around the filter to avoid contamination.
3. With the machine off, spin off the filter from its head.
4. Clean the filter base, make sure none of the old gasket material is adhered.
5. Apply a thin film of lubricating oil to the gasket of the new filter.
6. Thread the new filter on the filter base until the gasket makes contact.
7. Tighten according to the instructions printed on the side of the replacement filter.
8. Start the engine to pressurize the hydraulic system and check for leaks.

SERVICE RECOMMENDATIONS

Electrical System

Battery – Clean*

SMCS Code: 1401-070

Clean the battery surface with a clean cloth. Keep the terminals clean and keep the terminals coated with petroleum jelly. Install the post cover after you coat the terminal post with petroleum jelly.

Battery Electrolyte Level – Check*

SMCS Code: 1401-535-FLV; 1401; 1401-535

WARNING

All lead-acid batteries contain sulfuric acid which can burn the skin and clothing. Always wear a face shield and protective clothing when working on or near batteries.

NOTICE

If the machine is operated in extreme temperatures, check the electrolyte level Every 500 Service Hours or 3 months.

When the engine is not run for long periods of time or when the engine is run for short periods, the batteries may not fully recharge. Ensure a full charge in order to help prevent the battery from freezing.

1. Clean the battery surface with a clean cloth. Clean the terminals and the cable clamps. Coat the clamps and the terminals with silicone lubricant or petroleum jelly. Install the post cover.
2. Inspect the electrolyte level in each battery cell. Maintain the electrolyte level to the bottom of the filler openings. Use distilled water. If distilled water is not available, use clean drinking water.

Battery Hold-Down – Tighten*

SMCS Code: 7257

Tighten the hold-downs for the battery in order to prevent the batteries from moving during machine operation.

Battery or Battery Cable – Inspect/Replace*

WARNING

Personal injury can result from battery fumes or explosion.

Batteries give off flammable fumes that can explode. Electrolyte is an acid and can cause personal injury if it contacts the skin or eyes.

Prevent sparks near the batteries. Sparks could cause vapors to explode. Do not allow jumper cable ends to contact each other or the engine. Improper jumper cable connections can cause an explosion.

Always wear protective glasses when working with batteries.

1. Turn all the switches to the OFF position. Turn the engine start switch key to the OFF position.
2. Turn the battery disconnect switch to the OFF position. Remove the key.
3. Remove the battery hold-down.
NOTE: The machine may contain more than one set of batteries.
4. Disconnect the negative battery cable at the battery.
5. Disconnect the positive battery cable at the battery.
6. Disconnect the battery cable at the battery disconnect switch.
7. Inspect the battery terminals for corrosion. Clean the battery terminals and the surfaces of the batteries with a clean cloth.
8. Inspect the battery cables for wear or damage.
9. Make any necessary repairs. If necessary, replace the battery cables and/or the battery.
10. Connect the positive battery cable at the battery.
11. Connect the negative battery cable at the battery.
12. Coat the battery terminals with petroleum jelly to prevent corrosion and install the terminal covers.
13. Reinstall the battery hold-down. Tighten the hold-downs for the battery to prevent the batteries from moving during machine operation.
14. Connect the battery cable at the battery disconnect switch.
15. Install the key and turn the battery disconnect switch ON.

Recycle the Battery

Always recycle a battery. Never discard a battery.

Always return used batteries to one of the following locations:

- A battery supplier
- An authorized battery collection facility

Recycling facility

Camera – Clean*

⚠WARNING

Failure to use an appropriate external ladder or an appropriate platform for direct access to the rear view camera could result in slipping and falling which could result in personal injury or death. Be sure to use an appropriate external ladder or an appropriate platform for direct access to the rear view camera.

The machine's counterweight and the engine hood are not approved as a maintenance platforms.

⚠WARNING

Unexpected machine movement can cause injury or death. In order to avoid possible machine movement, move the hydraulic lockout control to the LOCKED position and attach a “Do Not Operate” or similar warning tag to the hydraulic lockout control.

NOTE: When you access the camera for cleaning, be sure to observe safe procedures for access. Maintain a three-point contact and/or use a body harness.



g06184579

Figure 10-159: Rear View Camera

The rear view camera is on top of the counterweight.

If necessary, use a damp cloth to clean the glass of the camera. The camera is sealed. The camera is not affected by a wash with high-pressure spray.

NOTE: Alternatively, cameras may be cleaned from ground level by using a wash with a high-pressure spray or a damp rag on a wand.

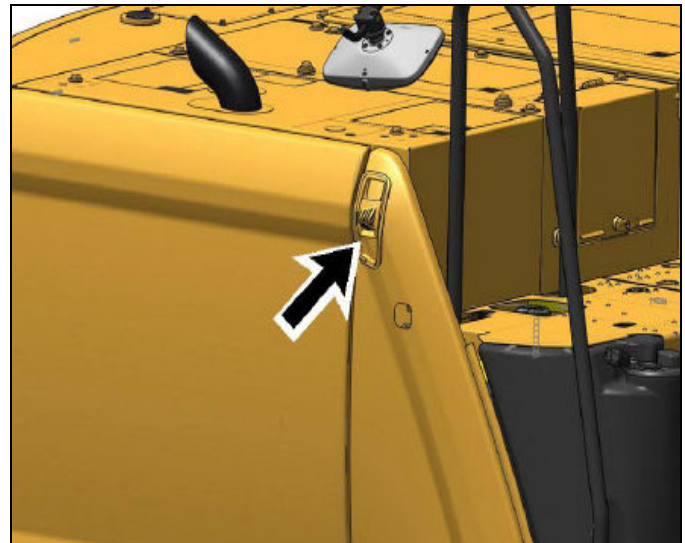

g06214504

Figure 10-160: Side View Camera

If equipped, clean the right side view camera.

SERVICE RECOMMENDATIONS



g06263435

Figure 10-161: 360 Visibility Camera - Left

If equipped, clean the left side view camera.

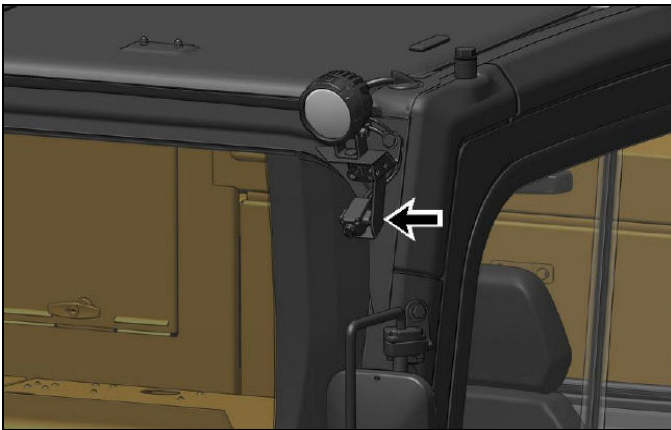

g06263449

Figure 10-162: 360 Visibility Camera - Front

If equipped, clean the front view camera.

Fuses – Replace*

SMCS Code: 1417-510

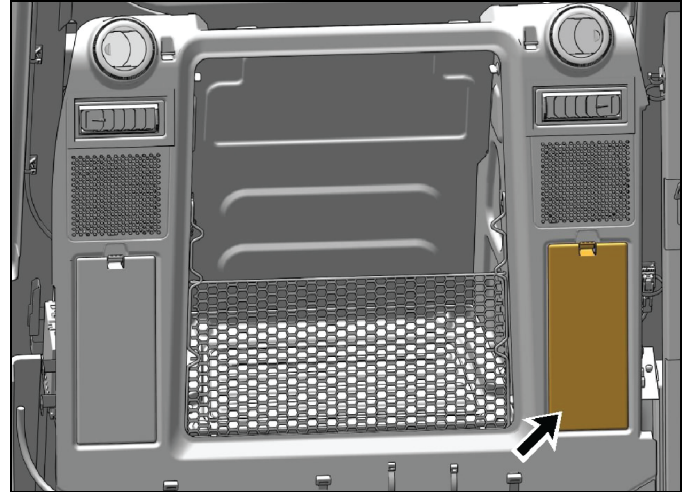

g06181624

Figure 10-163

The fuse panel is on the left side of the interior storage box. Remove the cover to access the fuses.



Fuses – Fuses protect the electrical system from damage that is caused by overloaded circuits. Change a fuse if the element separates. If the element of a new fuse separates, check the circuit and/or repair the circuit.

NOTICE

Always replace fuses with the same type and capacity fuse that was removed. Otherwise, electrical damage could result.

NOTICE

If it is necessary to replace fuses frequently, an electrical problem may exist. Contact the CZM After Sales Department support for service.

Fuse Identification*

To replace a fuse, use the puller that is stored in the fuse panel.

The following list identifies the circuits that are protected by each fuse. The amperage for each fuse is included with each circuit.

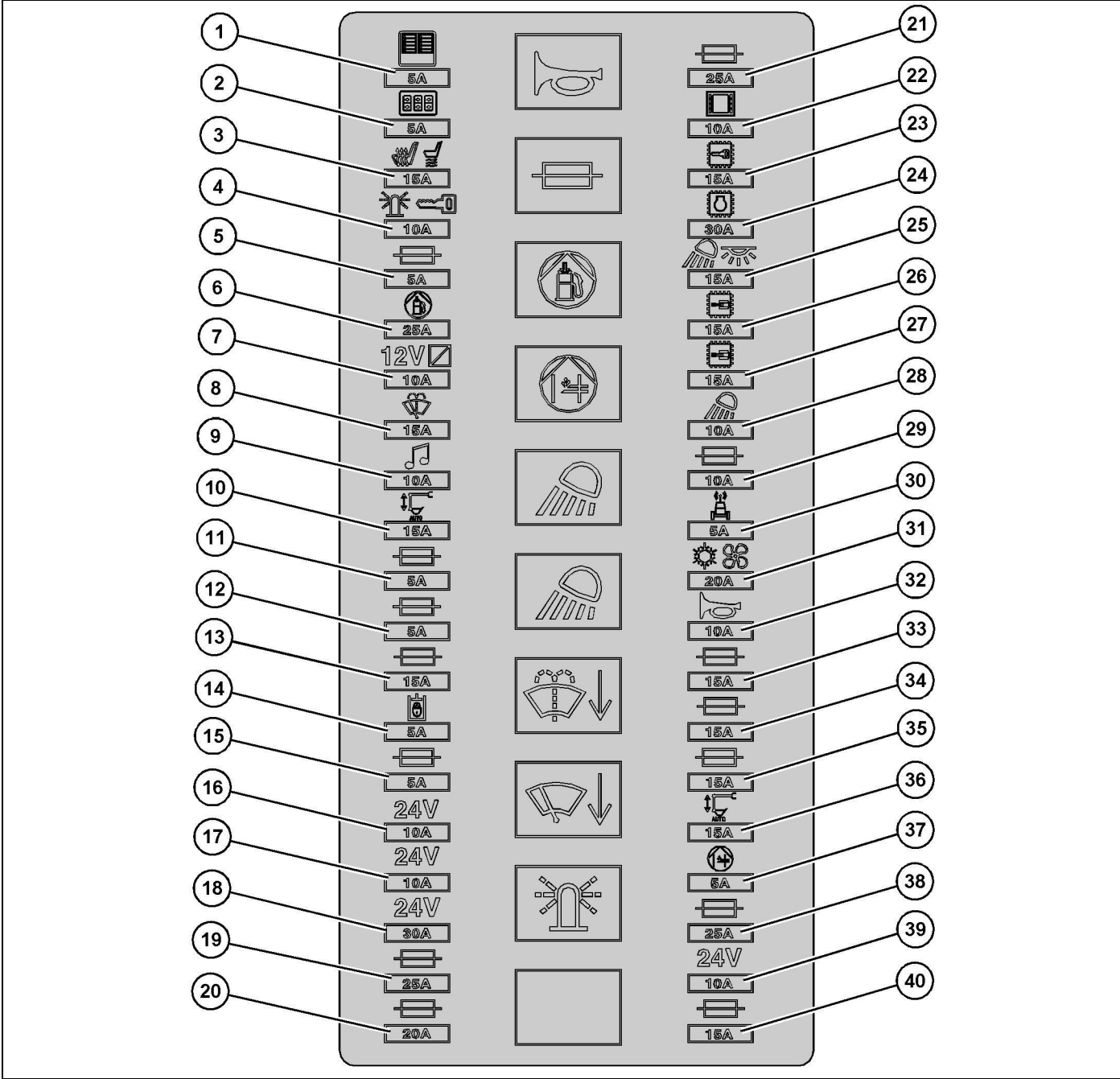

Figure 10-164

g06223505

- (1) Heater and Air Conditioner Control and Monitor – 5 Amp
- (2) Electronic Switch Control Panel – 5 Amp
- (3) Grip, Seat Heater, and Air Suspension Seat – 15 Amp
- (4) Beacon – 10 Amp
- (5) Spare – 5 Amp



SERVICE RECOMMENDATIONS

- (6) Electric Refueling Pump – 25 Amp
- (7) 12V Converter – 10 Amp
- (8) Window Wiper and Window Washer – 15 Amp
- (9) Radio – 10 Amp
- (10) Grade Control – 15 Amp
- (11) Spare – 5 Amp
- (12) Spare – 5 Amp
- (13) Spare – 15 Amp
- (14) Hydraulic Lock – 5 Amp
- (15) Spare – 5 Amp
- (16) Spare – 10 Amp
- (17) 24V Auxiliary Circuit – 10 Amp
- (18) 24V Auxiliary Circuit – 30 Amp
- (19) Spare – 20 Amp
- (20) Spare – 10 Amp
- (21) Spare – 25 Amp
- (22) Display and Et Connector – 10 Amp
- (23) Body Control Module – 15 Amp
- (24) Engine Electronic Control Module – 30 Amp
- (25) Dome Light – 15 Amp
- (26) Primary Electronic Control Module – 15 Amp
- (27) Secondary Electronic Control Module – 15 Amp
- (28) Boom Lamp – 10 Amp
- (29) Spare – 10 Amp
- (30) Product Link Module – 5 Amp
- (31) Air Conditioner and Heater Blower – 20 Amp
- (32) Horn – 10 Amp
- (33) Spare – 15 Amp
- (34) Spare – 15 Amp
- (35) 12V Converter – 10 Amp
- (36) Grade Control – 15 Amp
- (37) Fuel Lifting Pump – 5 Amp
- (38) Spare – 25 Amp
- (39) Auxiliary Circuit – 10 Amp
- (40) Spare – 15 Amp

Relay Identification

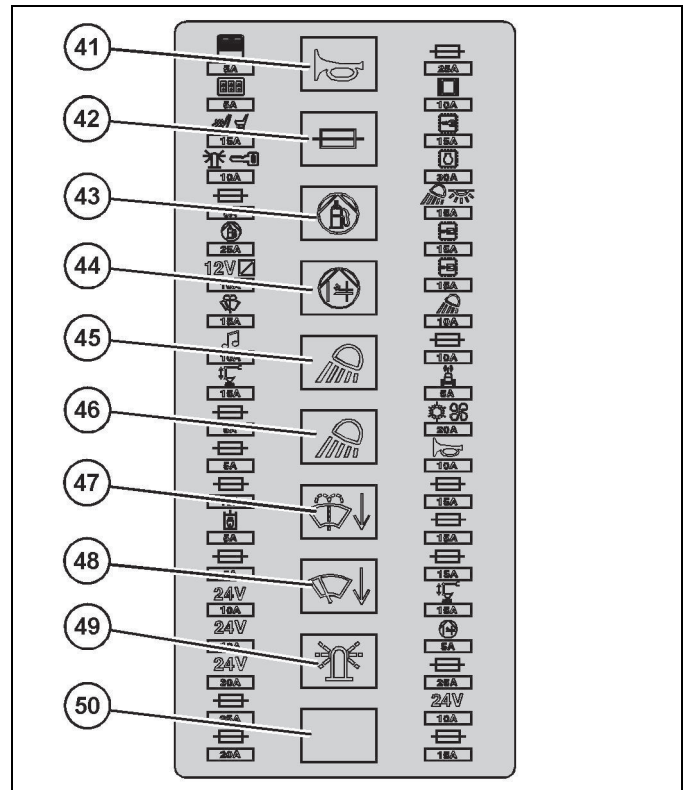

Figure 10-165

g06223517

- (41) Horn – Relay
- (42) DEF Pump – Relay
- (43) Grip, Seat Heater, and Air Suspension Seat – Relay
- (44) Lifting Pump – Relay
- (45) Boom Light – Relay
- (46) Chassis Light and Cab Light – Relay
- (47) Lower Washer – Relay
- (48) Lower Wiper – Relay
- (49) Caution – Relay
- (50) Spare – Relay

Power Fuse Module*

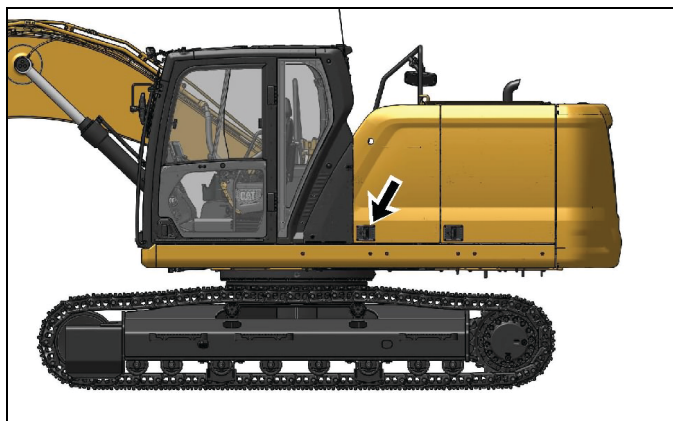

Figure 10-166

g06181546

The power fuse module is located behind the front access door on the left side of the machine. Remove the cover to access the fuses.

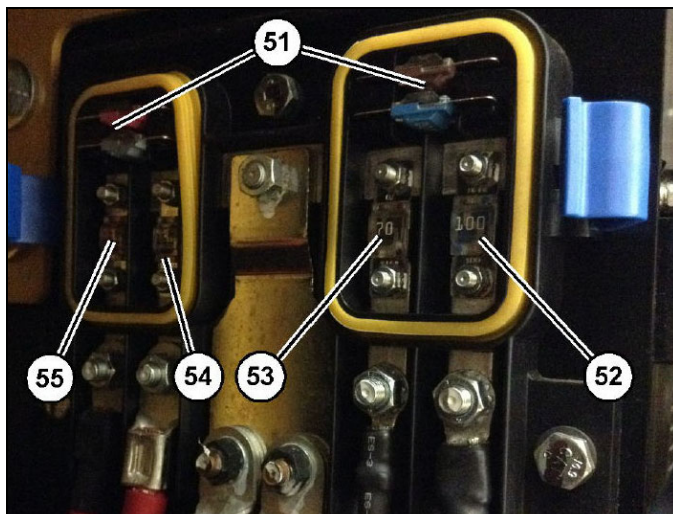

Figure 10-167

g06225641



Spares (51) – The fuse module includes spare fuses which can be used if one of the installed fuses opens. One spare fuse is provided for each fuse in use.



Electric Cooling Fans 100 Amp (52) (53) These fuses are designed to protect the glow plugs. **Note:** For machines with 11 electric fans, fuse (52) is 125 Amp.



Main Circuit 100 Amp (54) – This fuse is designed to protect the wires between the batteries and the fuses. If the wires are shorted to the machine body, this fuse would minimize the damage to the wires.



Alternator Circuit 150 Amp (55) – This fuse is designed to protect the alternator. If the batteries are installed with reversed polarity, the fuse would prevent the alternator from damaging the rectifier.

Secondary Power Fuse Module – 323 Tier 4 Only*

323 machines equipped with Tier 4 engines are equipped with a secondary power fuse module.

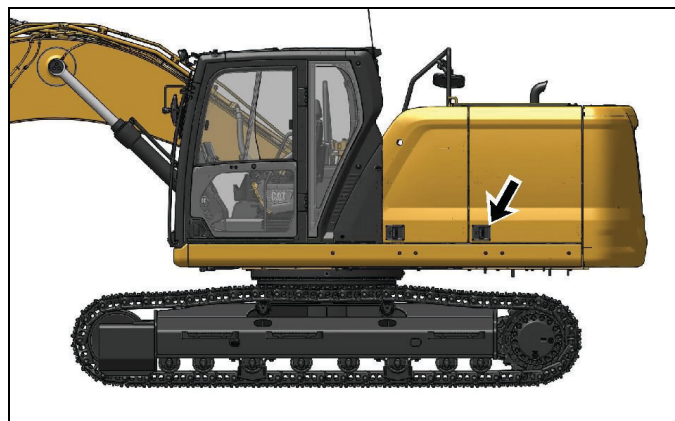

Figure 10-168

g06179792

The secondary power fuse module is located behind the rear access door on the left side of the machine. Remove the cover to access the fuses.

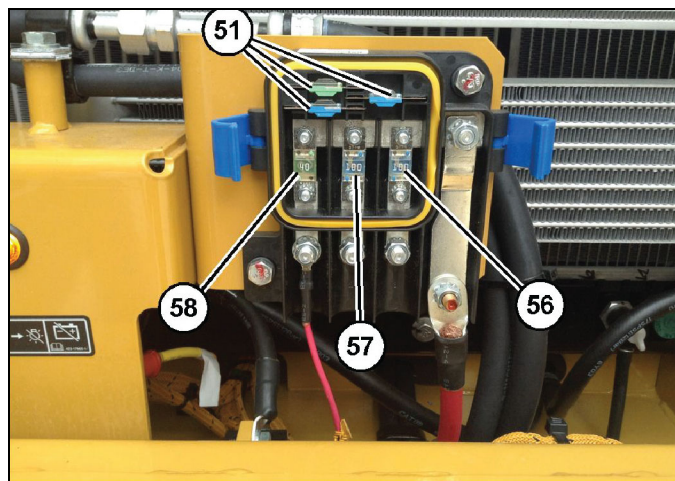

Figure 10-169: Typical Example

g06308723



Spare (51) – The fuse module includes spare fuses which can be used if one of the installed fuses opens. One spare fuse is provided for each fuse in use.

SERVICE RECOMMENDATIONS



Alternator Circuit 150 Amp (56) – This fuse is designed to protect the alternator. If the batteries are installed with reversed polarity, the fuse would prevent the alternator from damaging the rectifier.



Glow Plug Circuit 70 Amp (57) – This fuse is designed to protect the glow plugs.



Diesel Exhaust Fluid (DEF) Pump Circuit 40 Amp (58) – This fuse is designed to protect the DEF pump circuit.

High Intensity Discharge Lamp (HID) – Replace (If Equipped)*

SMCS Code: 1434-510

⚠ WARNING

HID lamps operate at very high voltages. To avoid electrical shock and personal injury, disconnect power before servicing HID lamps.

⚠ WARNING

HID bulb become very hot during operation. Before servicing, remove power from lamp for at least five minutes to ensure lamp is cool.

NOTICE

🌿 Although HID bulb materials may change over time, HID bulb produced at the time of the printing of this manual contain mercury. When disposing of this component, or any waste that contains mercury, please use caution and comply with any applicable laws.

1. Remove the electrical power from the high intensity discharge lamp (HID). The electrical power must be removed from the HID lamp for at least five minutes, in order to ensure that the bulb is cool.
2. Disassemble the housing for the HID lamp in order to have access to the bulb

NOTE: *On some HID lamps, the bulb is an integral part of the lens assembly. The bulb is not removed separately from the lens assembly. Replace the entire lens assembly on these HID lamps.*

3. Remove the bulb from the HID lamp.

4. Install the replacement bulb in the HID lamp.
If the bulb is an integral part of the lens assembly, install the replacement lens assembly in the HID lamp.

NOTE: *In order to avoid failure to the bulb that is premature, avoid touching the bulb's surface with your bare hands. Clean any fingerprints from the bulb with alcohol prior to operation.*

5. Reassemble the housing for the HID lamp. Ensure that any printing on the lens is oriented correctly with respect to the HID lamp's mounting position on the machine.
6. Reattach the electrical power to the HID lamp.
7. Check the HID lamp for proper operation.

NOTE: *Contact CZM for additional information on HID lamps.*

Cab

Air Conditioner/Cab Heater Filter (Recirculation) – Inspect/Replace*

SMCS Code: 1054-040-A/C; 1054-510-A/C

NOTICE

An air recirculation filter element plugged with dust will result in decreased performance and service life to the air conditioner or cab heater.

To prevent decreased performance, clean the filter element, as required.

The air conditioner filter is on the lower left side of the cab behind the seat.

1. Slide the operator seat forward.

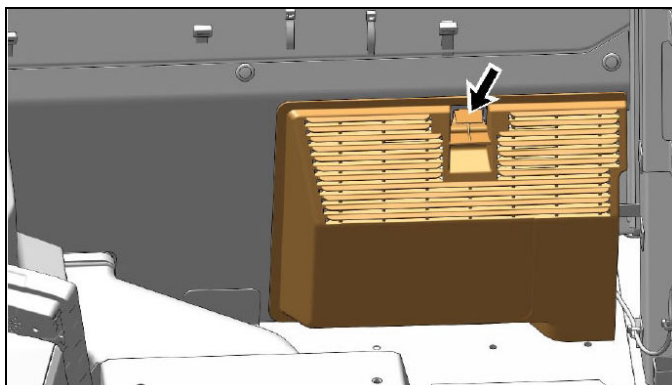

Figure 10-170

g06181599

2. Release the cover latch.

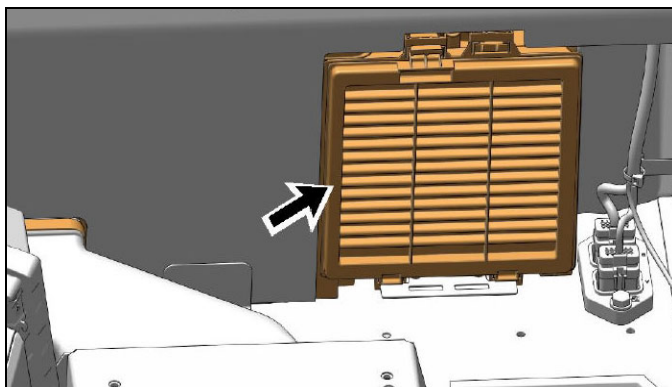

Figure 10-171

g06181603

3. Slide the filter element upward.
4. Tap the air filter to remove the dirt. Do not use compressed air to clean the filter.

5. After you clean the filter element, inspect the filter element. If the filter element is damaged or badly contaminated, use a new filter element. Make sure that the filter element is dry.

6. Install the filter element.

Install the cover.

Condenser (Refrigerant) – Clean*

SMCS Code: 1805-070

NOTICE

If excessively dirty, clean condenser with a brush. To prevent damage or bending of the fins, do not use a stiff brush.

Repair the fins if found defective.



Figure 10-172

g06179792

1. Open the access door on the left side of the machine. The condenser is located in front of the radiator.

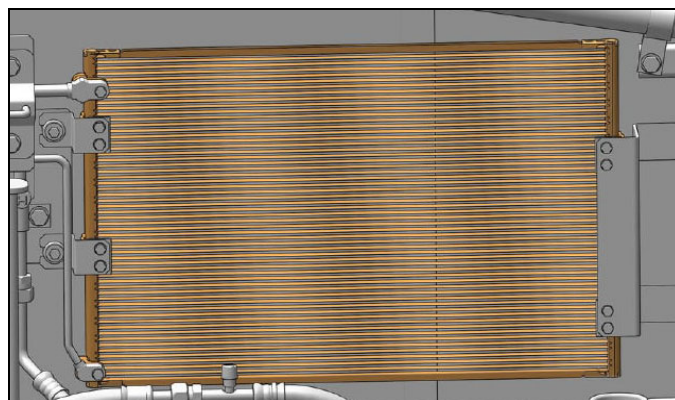

Figure 10-173

g06183025

2. Inspect the condenser for debris. Clean the condenser, if necessary.
3. Use clean water to wash off all dust and dirt from the condenser.

Close the access door.

SERVICE RECOMMENDATIONS

Receiver Dryer (Refrigerant) – Replace*

SMCS Code: 7322-510; 7322-710

⚠ WARNING

Personal injury can result from contact with refrigerant.

Contact with refrigerant can cause frost bite. Keep face and hands away to help prevent injury.

Protective goggles must always be worn when refrigerant lines are opened, even if the gauges indicate the system is empty of refrigerant.

Always use precaution when a fitting is removed. Slowly loosen the fitting. If the system is still under pressure, release it slowly in a well ventilated area.

Personal injury or death can result from inhaling refrigerant through a lit cigarette.

Inhaling air conditioner refrigerant gas through a lit cigarette or other smoking method or inhaling fumes released from a flame contacting air conditioner refrigerant gas, can cause bodily harm or death.

Do not smoke when servicing air conditioners or wherever refrigerant gas may be present.

Use a certified recovery and recycling cart to properly remove the refrigerant from the air conditioning system.

NOTICE

If the refrigerant system has been open to the outside air (without being plugged) for more than 30 minutes, the receiver-dryer must be replaced. Moisture will enter an open refrigerant system and cause corrosion which will lead to component failure.

Contact the CZM After Sales Department for the proper procedure to change the receiver-dryer assembly and for the procedure to reclaim the refrigerant gas.

Cab Air Filter (Fresh Air) – Clean/Replace*

SMCS Code: 7342-070; 7342-510

1. Use the ignition key to open the access panel.

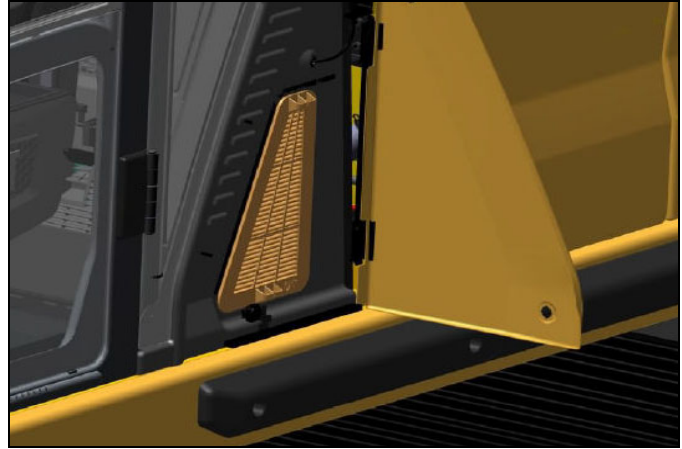

Figure 10-174

g06182115

2. Remove air filter (1).
3. Tap the air filter to remove the dirt. Do not use compressed air to clean the filter.
4. After you clean the air filter, inspect the air filter. If the air filter is damaged or badly contaminated, use a new air filter.
5. Install the air filter.

Close and lock the access panel

Rollover Protective Structure (ROPS) – Inspect*

SMCS Code: 7323-040; 7325-040

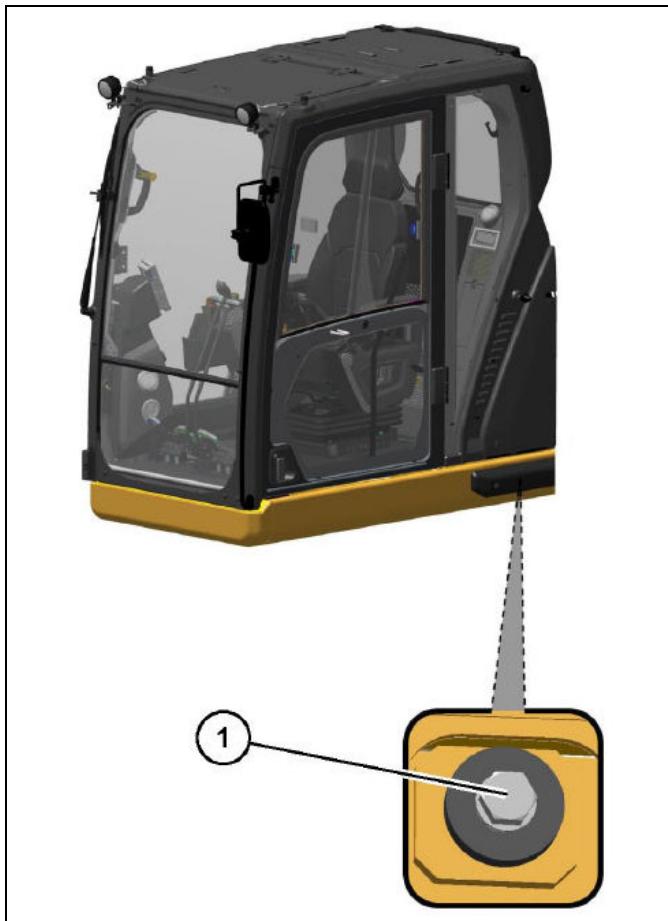

g06184357

Figure 10-175: ROPS Bolts

Contact CZM for repair of any cracks in the ROPS.

Inspect the ROPS for loose bolts or for damaged bolts. Replace any damaged bolts or missing bolts with original equipment parts only. Tighten the M24 bolt (1) to 425 ± 50 N·m (315 ± 40 lb ft).

NOTE: Apply oil to all ROPS bolt threads before you install the bolts. Failure to apply oil to the bolt threads can result in improper bolt torque.

Do not straighten the ROPS. Do not repair the ROPS by welding reinforcement plates to the ROPS.

Consult your CZM after-sales support for inspection of any potential damage or repair of any damage to any operator protective structure. (Including ROPS, FOPS, TOPS, OPS, and OPG).

Seat Belt – Inspect*

SMCS Code: 7327-040

Always inspect the condition of the seat belt and the condition of the seat belt mounting hardware before you operate the machine. Replace any parts that are damaged or worn before you operate the machine.



g06224278

Figure 10-176: Typical Example

Inspect buckle (2) for wear or for damage. If the buckle is worn or damaged, replace the seat belt.

Inspect seat belt (1) for webbing that is worn or frayed. Replace the seat belt if the webbing is worn or frayed.

Inspect all seat belt mounting hardware for wear or for damage. Replace any mounting hardware that is worn or damaged. Make sure that the mounting bolts are tight.

If your machine is equipped with a seat belt extension, also perform this inspection procedure for the seat belt extension.

Contact CZM for the replacement of the seat belt and the mounting hardware.

NOTE: The seat belt should be replaced within 3 years of the date of installation. A date of installation label is attached to the seat belt retractor and buckle. If the date of installation label is missing, replace belt within 3 years from the year of manufacture as indicated on belt webbing label, buckle housing, or installation tags (non-retractable belts)

SERVICE RECOMMENDATIONS

Seat Belt – Replace*

SMCS Code: 7327-510

The seat belt should be replaced within 3 years of the date of installation. A date of installation label is attached to the seat belt retractor and buckle. If the date of installation label is missing, replace the belt within 3 years from the year of manufacture as indicated on the belt webbing label, buckle housing, or installation tags (non-retractable belts).

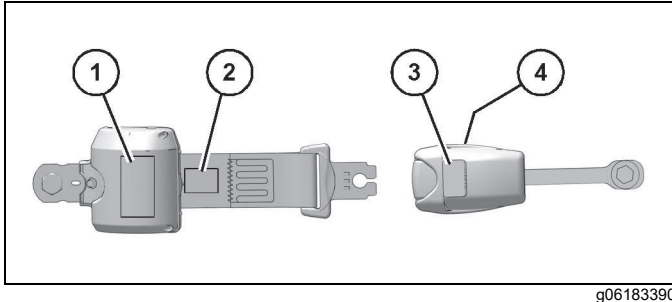

Figure 10-177: Seat Belt Components

- (1) Date of installation (retractor)
- (2) Year of manufacture (tag) (fully extended web)
- (3) Date of installation (buckle)
- (4) Year of manufacture (underside) (buckle)

Contact the CZM After Sales Department for the replacement of the seat belt and the mounting hardware.

Determine the age of a new seat belt before installing on seat. A manufacture label is on the belt webbing and imprinted on the belt buckle. Do not exceed the install by date on the label.

A complete seat belt system should be installed with new mounting hardware.

Date of installation labels should be marked and affixed to the seat belt retractor and buckle.

NOTE: *Date of installation labels should be permanently marked by punch (retractable belt) or stamp (non-retractable belt).*

If your machine is equipped with a seat belt extension, also perform this replacement procedure for the seat belt extension.

Windows – Clean*

SMCS Code: 7310-070; 7340-070

Clean the outside of the windows from the ground using a pole extension, unless handholds are available.

Cleaning Methods*

Aircraft Window Cleaner*

Apply the cleaner with a soft cloth. Rub the window with moderate pressure until all the dirt is removed. Allow the cleaner to dry. Wipe off the cleaner with a clean soft cloth.

Soap and Water*

Use a clean sponge or a soft cloth. Wash the windows with a mild soap or with a mild detergent. Also use plenty of lukewarm water. Rinse the windows thoroughly. Dry the windows with a moist chamois or with a moist cellulose sponge.

Stubborn Dirt and Grease*

Wash the windows with a good grade of naphtha, of isopropyl alcohol, or of Butyl Cellosolve. Then, wash the windows with soap and with water.

Polycarbonate Windows (If equipped)

Special care is needed to clean polycarbonate windows. Wash polycarbonate windows with mild soap and warm water that does not exceed 50° C (122° F). Use a soft sponge, or damp cloth. Never use a dry cloth or paper towels on polycarbonate windows. Rinse the windows with a sufficient amount of clean cold water.

NOTICE

Naphtha or kerosene can be used to remove labels, paint, or marking pen from polycarbonate windows.

NOTE: *Do not use abrasive, or highly alkaline cleaners. Do not use sharp instruments, such as squeegees or razor blades on polycarbonate windows. Do not clean polycarbonate windows in the hot sun or at elevated temperatures.*

Window Washer Reservoir – Fill*

SMCS Code: 7306-544-KE

NOTICE

When operating in freezing temperatures, use any commercially available nonfreezing window washer solvent.



Figure 10-178

g06181546

1. Open the access door on the left side of the machine.

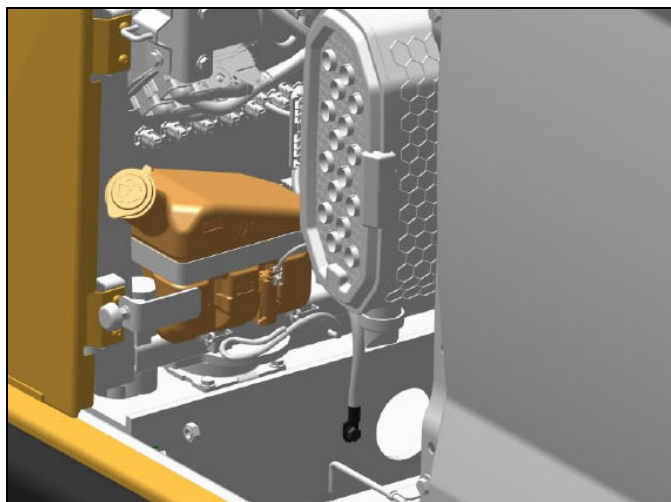

Figure 10-179

g06181644

2. Remove the filler cap.
3. Fill the window washer reservoir with washer fluid through the filler opening.
4. Install the filler cap.
5. Close the access door.

Window Wiper – Inspect/ Replace*

SMCS Code: 7305-040; 7305-510

Inspect the condition of the wiper blades. Replace the wiper blades if the wiper blades are worn or damaged or if streaking occurs.

Decal (Product Identification) – Clean



Figure 10-180

0000331



Figure 10-181

0000332

Cleaning of the Decals

Make sure that all the product identification decals are legible. Make sure that the recommended procedures are used to clean the product identification decals. Ensure that all the product identification decals are not damaged or missing. Clean the product identification decals or replace the decals.

Hand Washing

Use a wet solution with no abrasive material that contains no solvents and no alcohol. Use a wet solution with a pH value between 3 and 11. Use a soft brush, a rag, or a sponge to clean the product identification decals. Avoid wearing down the surface of the product identification decals with unnecessary scrubbing. Ensure that the surface of the product identification decal is flushed with clean water and allow the product identification decals to air dry.

Power Washing

Power washing or washing with pressure may be used to clean product identification decals. However, aggressive washing can damage the product identification decals.

SERVICE RECOMMENDATIONS

Excessive pressure during power washing can damage the product identification decals by forcing water underneath the product identification decals. Water lessens the adhesion of the product identification decal to the product, allowing the product identification decal to lift or curl. These problems are magnified by wind. These problems are critical for the perforated decal on windows.

To avoid lifting of the edge or other damage to the product identification decals, follow these important steps:

- Use a spray nozzle with a wide spray pattern.
- A maximum pressure of 83 bar (1200 psi)
- A maximum water temperature of 50° C (120° F)
- Hold the nozzle perpendicular to the product identification decal at a minimum distance of 305 mm (12 inch).

Do not direct a stream of water at a sharp angle to the edge of the product identification decal.

Swing Maintenance

Swing Bearing – Lubricate*

SMCS Code: 7063-086

NOTE: See “Fluids and Lubricants” on page 10-11. Contact the CZM After Sales Department if more information on grease is required.

NOTE: Do not over-grease the swing bearings. Do not grease more than the recommended maintenance interval. Refer to “Maintenance Plan” on page 10-7 for more information.

Wipe the fittings before you lubricate the swing bearing.

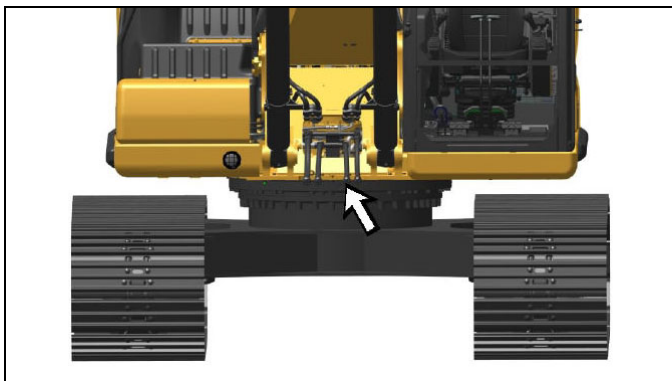

Figure 10-182: Swing-Bearing Grease Zerk Location

The swing bearing grease zerks are located at the front of the swing drive housing.

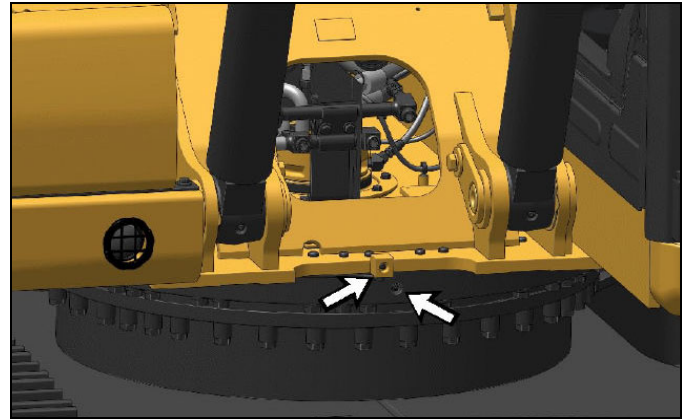

Figure 10-183: Swing-Bearing Fittings Location

Apply lubricant through the fittings until the lubricant overflows the bearing seals.

Swing Drive Oil – Change*

SMCS Code: 5459-044

WARNING

Hot oil and hot components can cause personal injury. Do not allow hot oil or hot components to contact skin.

NOTICE

Care must be taken to ensure that fluids are contained during performance of inspection, maintenance, testing, adjusting, and repair of the machine. Be prepared to collect the fluid with suitable containers before opening any compartment or disassembling any component containing fluids.

Contact the CZM After Sales Department for tools and supplies suitable to collect and contain fluids on CZM products.

Dispose of all fluids according to local regulations and mandates.

SERVICE RECOMMENDATIONS

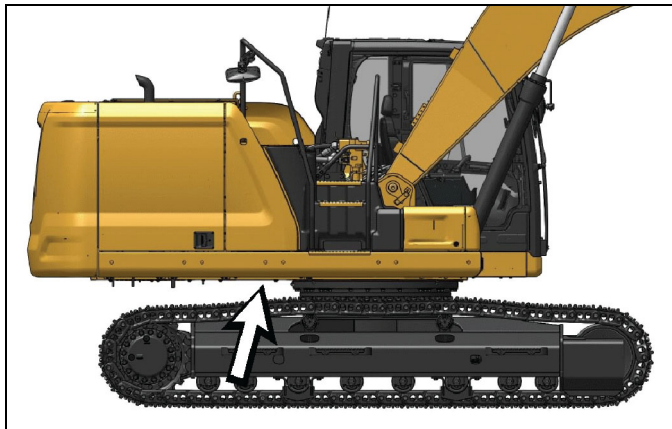

Figure 10-184

g06188541

1. Remove the access cover that is located below the swing drives.

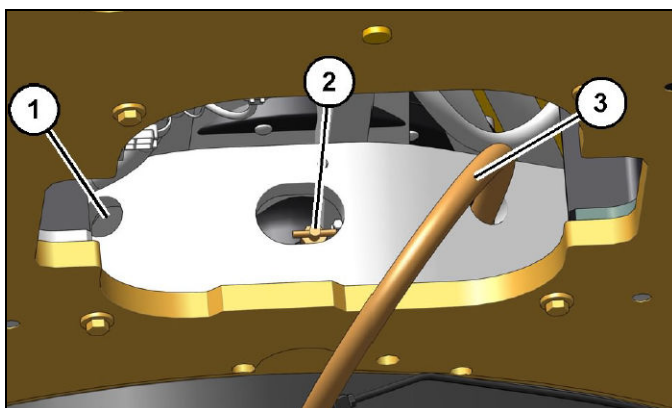

Figure 10-185

g06192018

NOTE: Refer to “General Safety*” on page 2-11 for information on Containing Fluid Spillage.

2. Remove drain hose (3) from holder (1) on the upper frame. Face the end of the hose toward the container.
3. Loosen drain valve (2). Drain the oil into a suitable container.

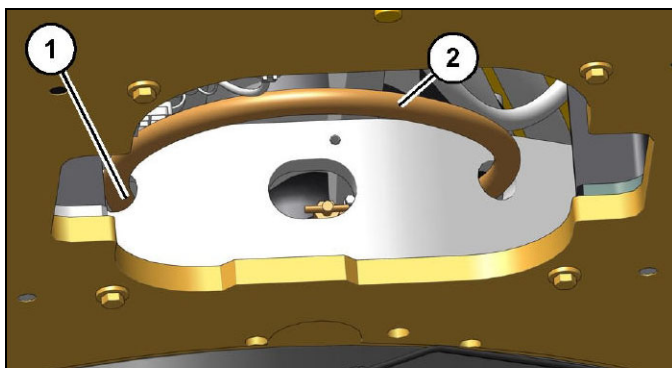

Figure 10-186

g06192024

4. Tighten the drain valve. Return the drain hose to holder (1). Make sure that the end of the hose is facing upward.

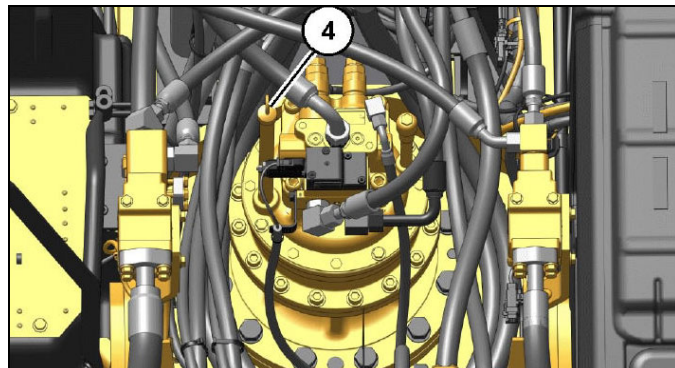

Figure 10-187

g06188581

5. Remove dipstick (4).
6. Add the specified quantity of oil through the dipstick tube. See “Fluids and Lubricants” on page 10-11.



Figure 10-188

g06188660

7. Maintain the oil level between the “ADD” and “FULL” marks on the dipstick.
8. Check the oil that has been drained for metal chips or metal particles. Contact CZM After Sales Department if any metal chips or metal particles are found.
9. Drained materials should always be disposed of according to local regulations.

SERVICE RECOMMENDATIONS

Swing Drive Oil Level – Check*

SMCS Code: 5459-535-FLV

⚠ WARNING

Hot oil and hot components can cause personal injury. Do not allow hot oil or hot components to contact skin.



Figure 10-189

g06188672

The dipstick for the swing drive oil is on the swing drive at the rear base of the boom.

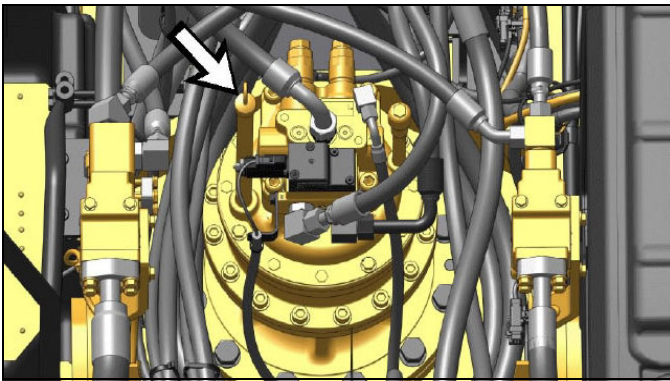

Figure 10-190

g06188677

1. Remove the dipstick.

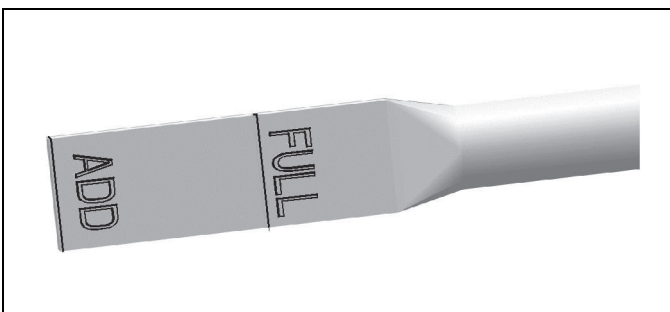

Figure 10-191

g06188660

NOTE: Refer to Operation and Maintenance Manual, General Hazard Information for information that pertains to Containing Fluid Spillage.

2. Check the dipstick. Maintain the oil level between the “ADD” and “FULL” marks on the dipstick. Add oil through the dipstick tube, if necessary. Refer to “Fluids and Lubricants” on page 10-11 when you select an oil. If the oil level is above the “FULL” line, then remove oil from the system. Restore the oil to the correct level position.
3. Insert the dipstick.

Swing Drive Oil Sample – Obtain*

SMCS Code: 5459-554-OC; 5459-008; 5459-008-OC; 5459-OC; 7542-008

⚠ WARNING

Hot oil and hot components can cause personal injury. Do not allow hot oil or hot components to contact skin.

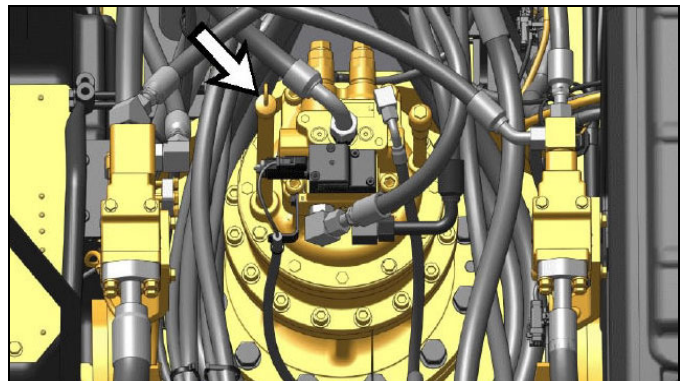

Figure 10-192

g06188677

Obtain an oil sample of the swing drive oil through the opening for the dipstick. Contact CZM After Sales Department for information that pertains to obtaining an oil sample from the swing drive housing.

Swing Gear – Lubricate*

SMCS Code: 7063-086

NOTE: Refer to “Fluids and Lubricants” on page 10-11 for more information on grease.

NOTICE

Improper lubrication can cause damage to machine components.

To avoid damage, make sure that the proper amount of grease is applied to the swing drive.

When the amount of grease in the compartment becomes too large, the agitation loss becomes large, thereby accelerating grease deterioration.

Grease deterioration can cause damage to the pinion gear of the swing drive and swing internal gear.

Not enough grease will result in poor gear lubrication.

Remove the inspection cover that is located near the mast base. Inspect the grease.

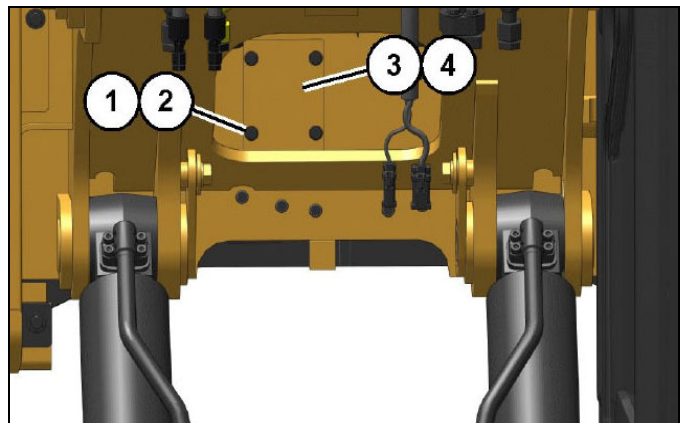

Figure 10-193

- (1) Bolts
- (2) Washers
- (3) Cover
- (4) Gasket

1. Remove bolts (1) and washers (2). Remove cover (3) and gasket (4).
2. Inspect gasket (4). Replace the gasket if damage is evident.

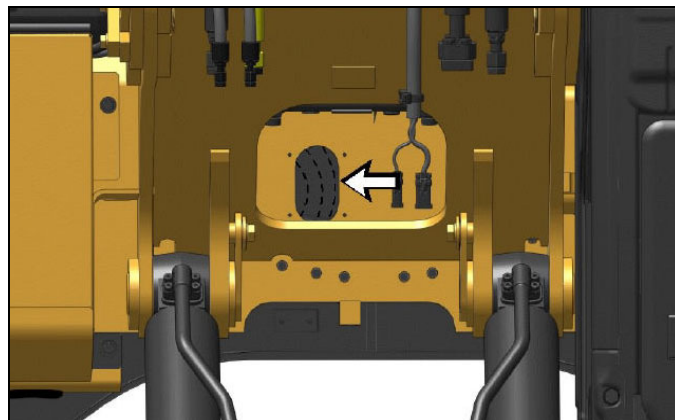

Figure 10-194

3. Check the level of grease. The level of grease is correct when:
 - Waves of grease are present from the rotating swing drive pinion.
 - The grease is evenly distributed on the floor of the pan.

NOTICE

Smearing or waveless areas are evidence for a lack of grease.

NOTE: Add grease, as needed. Remove grease, as needed. Too much grease will result in the deterioration of the grease because of excessive movement of the grease. Too little grease will result in poor lubrication of the swing gear.

Refer to **Chapter 4, “Technical Specifications”** for the size of the pan.

4. Check for contamination and for discolored grease.

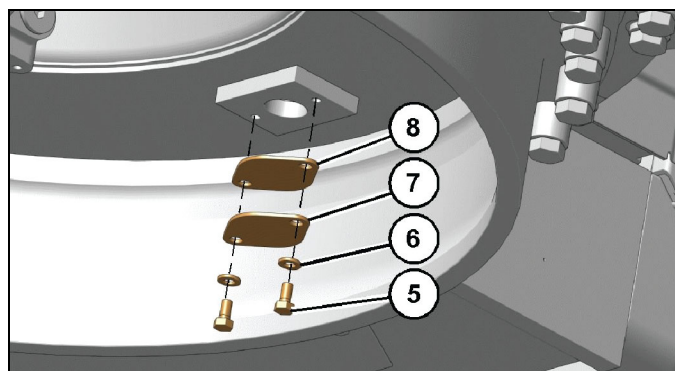

Figure 10-195

- (5) Bolts
- (6) Washers
- (7) Cover
- (8) Gasket

SERVICE RECOMMENDATIONS

5. If the grease is contaminated or discolored with water, change the grease. Remove the covers from below the swing drive underneath the undercarriage frame.
6. Remove bolts (5), washers (6), cover (7), and gasket (8) to allow the water to drain. When you reinstall cover (7), inspect gasket (8). Replace the gasket if damage is evident.
7. Raise the boom and mast and turn the upper structure by $\frac{1}{4}$ turn. Lower the boom and mast until the work tool touches the ground
8. Repeat Step 7 at every $\frac{1}{4}$ turn in four places. Add grease, as needed.
9. Install gasket (4), cover (3), washers (2), and bolts (1).

Undercarriage

Undercarriage – Check*

SMCS Code: 4150-535

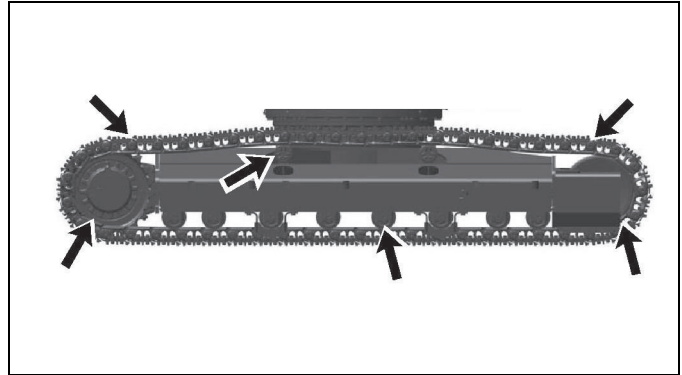

Figure 10-196

1. Check the carrier rollers, the track rollers, and the idler wheels for possible leakage.
2. Check the surface of the track, the carrier rollers, the track rollers, the idler wheels, the track shoes, and the drive sprockets. Look for signs of wear and loose mounting bolts.
3. Listen for any abnormal noises while you are moving slowly in an open area.

If abnormal wear exists or abnormal noises or leaks are found, contact CZM.

Travel Alarm – Test*

SMCS Code: 7429-081

Move the machine to test the travel alarm.

1. Start the engine. Move the hydraulic lockout control to the UNLOCKED position.
2. Raise the work tool to avoid any obstacles. Make sure that there is adequate overhead clearance.



Figure 10-197

g06181402

3. Use the travel levers or the travel pedals to move the machine forward. The travel alarm should sound.
4. Release the travel levers and the travel pedals to stop the machine.
5. Use the travel levers and the travel pedals to move the machine backward. The travel alarm should sound.



Figure 10-198

g06181631

6. Press the alarm mute button. The travel alarm should shut off.
7. Stop the machine. Lower the work tool to the ground. Move the hydraulic lockout control to the LOCKED position. Stop the engine.

Track Adjustment – Adjust*

SMCS Code: 4170-025

⚠ WARNING

Personal injury or death can result from grease under pressure.

Grease coming out of the relief valve under pressure can penetrate the body causing injury or death.

Do not watch the relief valve to see if grease is escaping. Watch the track or track adjustment cylinder to see if the track is being loosened.

Loosen the relief valve one turn only.

If track does not loosen, close the relief valve and contact CZM.

NOTICE

Keeping the track properly adjusted will increase the service life of the track and drive components.

Measuring Track Tension*

1. Operate the machine in the direction of the idlers.

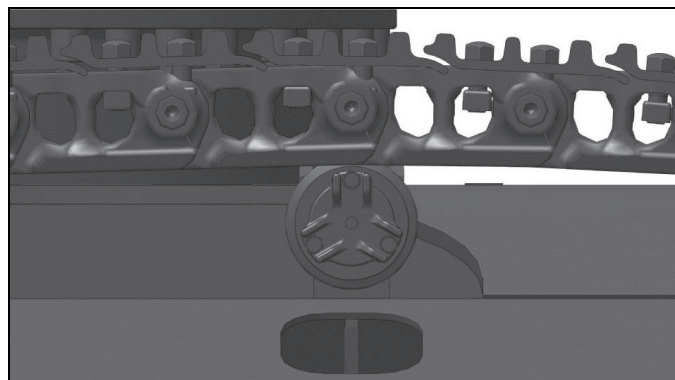

Figure 10-199

g06188816

2. Stop with one track pin directly over the front carrier roller. Park the machine and turn off the engine.

SERVICE RECOMMENDATIONS



Figure 10-200

g06208711

- Place a straight edge on top of the track grousers between the front carrier roller and the idler. The straight edge should be long enough to reach from the front carrier roller to the idler.

NOTE: If your machine is equipped with three carrier rollers, place a straight edge on the tracks between the carrier rollers. The straight edge should be long enough to reach from one carrier roller to another carrier roller.

- Measure the maximum amount of sag in the track. The sag is measured from the highest point of the track grouser to the bottom of the straight edge. A track that is properly adjusted will have a sag of 40.0 to 55.0 mm (1.57 to 2.17 inch).
- If the track is too tight, or if the track is too loose, adjust the track tension according to the appropriate procedure below.

Adjusting Track Tension*

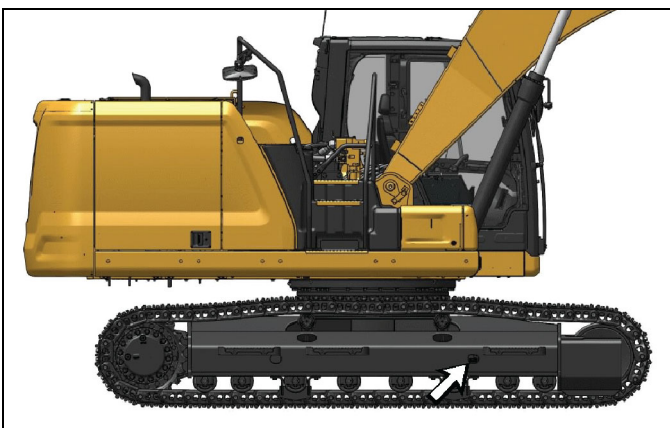
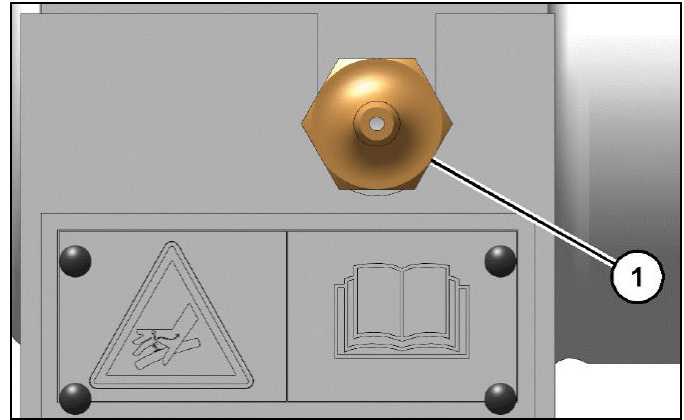

Figure 10-201: Typical Example

g06188820

The track adjuster is located on the track frame.

Tightening the Track*



g06188830

Figure 10-202: Track Grease Valve

- Grease valve

Wipe the fitting before you add grease.

- Add grease through grease valve (1) until the correct track tension is reached.
- Operate the machine back and forth in order to equalize the pressure.
- Check the amount of sag. Adjust the track, as needed.

Loosening the Track*

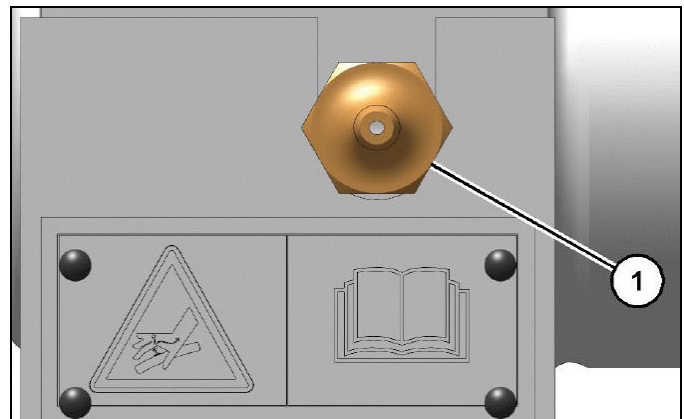

g06188830

Figure 10-203: Track Grease Valve

- Loosen grease valve (1) carefully until the track begins to loosen. One turn should be the maximum.
- Tighten grease valve (1) to $34 \pm 5 \text{ N}\cdot\text{m}$ ($25 \pm 4 \text{ lb ft}$) when the desired track tension is reached.
- Operate the machine back and forth in order to equalize the pressure.
- Check the amount of sag. Adjust the track, as needed.

Track Adjustment – Inspect*

SMCS Code: 4170-040

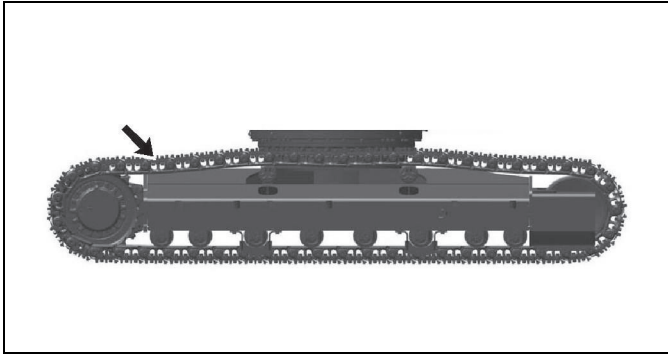

Figure 10-204

g06182929

Check the track adjustment. Check the track for wear and for excessive dirt buildup.

If the track appears to be too tight or too loose, refer to “Track Adjustment – Adjust*” on page 10-95.

Final Drive

Final Drive Oil – Change*

SMCS Code: 4050-044-FLV

⚠WARNING

Hot oil and hot components can cause personal injury. Do not allow hot oil or hot components to contact skin.

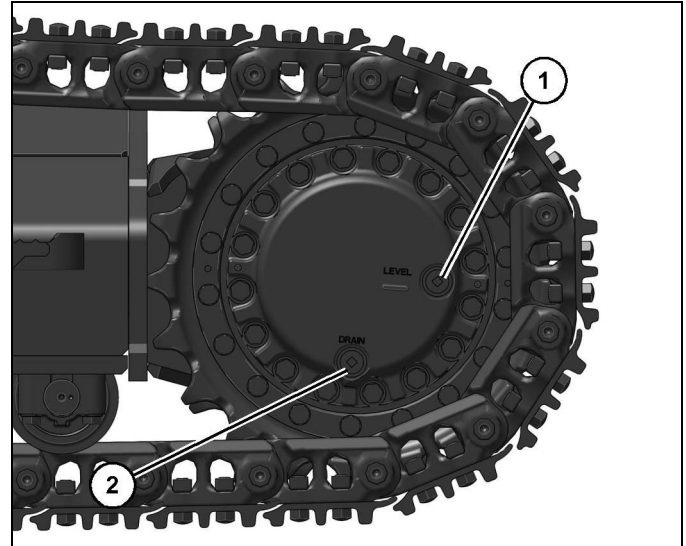

g06182944

Figure 10-205: Final Drive Drain and Level Plugs

- (1) Oil level plug
- (2) Oil drain plug

1. Position one final drive so that oil drain plug (2) is at the bottom.

NOTE: Refer to “General Safety*” on page 2-11 for information on Containing Fluid Spillage.

2. Remove drain plug (2) and level plug (1). Allow the oil to drain into a suitable container.
3. Clean the plugs and inspect the O-ring seals. If wear or damage is evident, replace the drain plug, the level plug, and/or the O-ring seals.
4. Install drain plug (2).
5. Fill the final drive to the bottom of the opening on level plug (1). See “Fluids and Lubricants” on page 10-11.

NOTE: If the oil fills slowly, the fill hole may be blocked by the planetary gear. Rotate the final drive to move the planetary gear away from the fill hole.

NOTE: Overfilling the final drive will cause the seals on the travel motor to allow hydraulic oil or water to

SERVICE RECOMMENDATIONS

enter the final drive. The final drive may become contaminated.

6. Install level plug (1).
7. Perform Step 1 to Step 6 on the other final drive. Use a different container for the oil so that the oil samples from the final drives will be separate.
8. Completely remove the oil that has spilled onto surfaces.
9. Start the machine and allow the final drives to run through several cycles.
10. Stop the machine. Check the oil level.
11. Check the drained oil for metal chips or for particles. If there are any chips or particles, contact CZM After Sales Department
12. Properly dispose of the drained material. Obey local regulations for the disposal of the material.

Final Drive Oil Level – Check*

SMCS Code: 4050-535-FLV

⚠ WARNING

Hot oil and hot components can cause personal injury. Do not allow hot oil or hot components to contact skin.

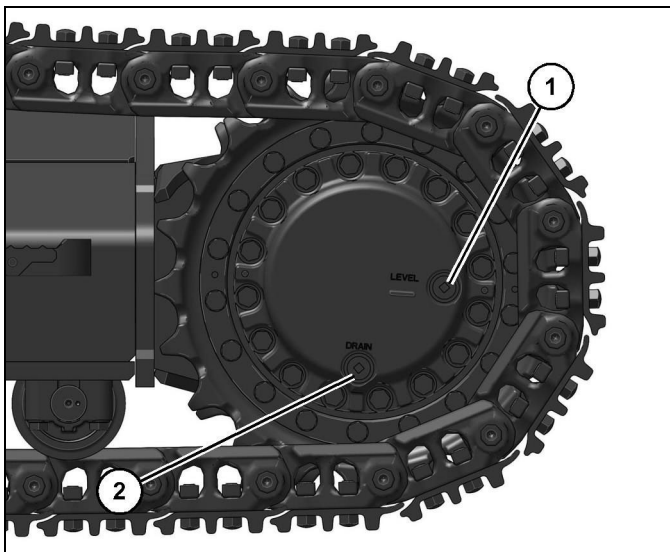

Figure 10-206: Final Drive Drain and Level Plugs

- (1) Oil level plug
- (2) Oil drain plug

1. Position one final drive so that oil drain plug (2) is at the bottom.

NOTE: Refer to “General Safety*” on page 2-11 for information on Containing Fluid Spillage.

2. Remove oil level plug (1).
3. Check the oil level. The oil should be near the bottom of the level plug opening.
4. 4. Add oil through the level plug opening, if necessary. See “Fluids and Lubricants” on page 10-11.

NOTE: If the oil fills slowly, the fill hole may be blocked by the planetary gear. Rotate the final drive to move the planetary gear away from the fill hole.

NOTE: Overfilling the final drive will cause the seals on the travel motor to allow hydraulic oil or water to enter the final drive. The final drive may become contaminated.

5. Clean oil level plug (1). Inspect the O-ring seal. Replace the O-ring seal if the O-ring seal is worn or damaged.
6. Install oil level plug (1).
7. Repeat the procedure for the other final drive.
- 8.

Final Drive Oil Sample – Obtain*

SMCS Code: 4011-008; 4050-SM; 4050-008; 7542-008

⚠ WARNING

Hot oil and hot components can cause personal injury. Do not allow hot oil or hot components to contact skin.

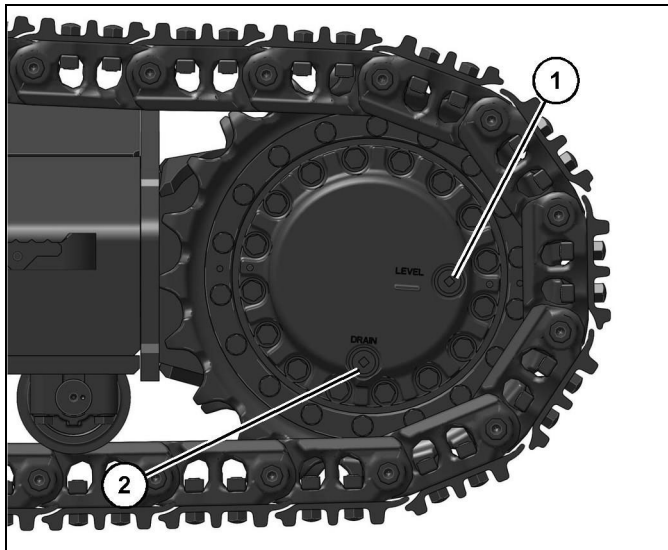

Figure 10-207

g06182944

- (1) Oil level plug
- (2) Oil drain plug

1. Position the final drive so that oil drain plug (2) is at the bottom.

NOTE: Refer to “General Safety*” on page 2-11 for information on Containing Fluid Spillage.

2. Remove oil level plug (1).
3. Obtain a sample of the final drive oil through the hole for the oil level plug.
4. Install oil level plug (1).

Contact CZM for more information on obtaining a sample of the final drive oil.

Torque Specifications

Unless otherwise specified, fasteners should be tightened in a cross pattern. Use the following procedure, unless the tightening sequence is specified:

1. Hand tighten all fasteners. Larger fasteners may require the use of a small hand wrench.
2. Tighten all fasteners to 40% of full torque.
3. Tighten all fasteners to 70% of full torque.
4. Tighten all fasteners to full torque by using a cross pattern. Large flanges may require additional passes.
5. Apply at least one final full torque to all fasteners in a clockwise direction until all torque is uniform. Large flanges may require additional passes.

Note: Final torque may be a turn.

⚠ WARNING

Prior to installation of any hardware:

- Make sure that components are in near new condition.
- Bolts and threads must not be worn or damaged.
- Threads must not have burrs or nicks.
- Hardware must be free of rust and corrosion.
- Clean reused fasteners with a noncorrosive cleaner.

Failure to follow this warning could result in death or serious injury.

⚠ CAUTION

When tightening fasteners:

- Too much tension on the bolt will cause the bolt to be stretched beyond the point of yield. The bolt will be permanently stretched and will loosen the grip on the parts that are being fastened. If the bolt is tightened again, the bolt will break.
- Do not reuse bolts that have been permanently stretched.
- All sealants and lubricating compounds must be removed (and reapplied where applicable) before reusing bolts.

SERVICE RECOMMENDATIONS

NOTICE

- **Be sure to use a torque wrench that has the proper range. Torque wrenches must be used properly in order to ensure that the correct torque is applied. Always use a smooth pull for torque wrenches, do not jerk a torque wrench, and do not use adapters that change the length of the torque wrench. For the correct use of your torque wrench, refer to the instructions that were packaged with your torque wrench.**
- **The torque table below must be used as a generic guideline for approximate bolt torques. Exact values depend on application, fastened materials, and many other variables. Exceptions and specific torques are reported in their respective procedures. Bolt torques in the table below apply to steel fasteners as per ISO (formerly DIN), values are based on the VDI2230 standard. CZM recommends the assembly methods on the following pages, reported torques are based on the resulting friction coefficients from these assembly methods.**
- **CZM recommends Loctite Red 262 threadlocker.**

Torque Table



Only use fasteners of same grade and type to replace original fasteners. Replacing fasteners with a lower grade or different type of fastener can result in serious injury or equipment failure.

Fastener size	Assembly Method
M5-M8	Dry assembly.
M10-M48	Oil lubricated /thread lock and anti-seize.

Fastener Size	Tightening Torque Values for Standard Metric Fasteners					
	Metric Grade 8.8		Metric Grade 10.9		Metric Grade 12.9	
	N•m	lb-ft	N•m	lb-ft	N•m	lb-ft
M 5*	6 ± 2	4 ± 1	8,5 ± 2	6 ± 2	10,2 ± 3	8 ± 2
M 6*	10,5 ± 3	8 ± 2	14,5 ± 4	11 ± 3	17,5 ± 4	13 ± 3
M 8*	25 ± 6	18 ± 5	35 ± 9	26 ± 6	42 ± 11	31 ± 8
M 10	41 ± 7	30 ± 5	57 ± 10	42 ± 8	69 ± 12	51 ± 9
M 12	70 ± 13	52 ± 9	99 ± 18	73 ± 13	119 ± 12	88 ± 16
M 14	112 ± 20	83 ± 15	157 ± 28	116 ± 21	189 ± 34	139 ± 25
M 16	170 ± 26	125 ± 19	240 ± 36	177 ± 27	285 ± 43	210 ± 32
M 18	235 ± 35	173 ± 26	330 ± 50	244 ± 37	395 ± 59	292 ± 44
M 20	330 ± 50	244 ± 37	465 ± 70	343 ± 51	560 ± 84	413 ± 62
M 22	445 ± 56	328 ± 41	625 ± 78	461 ± 78	755 ± 94	557 ± 70
M 24	570 ± 71	421 ± 53	800 ± 100	590 ± 74	965 ± 121	712 ± 89
M 27	840 ± 105	620 ± 77	1180 ± 148	871 ± 109	1420 ± 178	1048 ± 131
M 30	1140 ± 143	841 ± 105	1610 ± 201	1188 ± 149	1930 ± 241	1424 ± 178
M 33	154 ± 143	1137 ± 142	2170 ± 271	1601 ± 200	2600 ± 325	1919 ± 240
M 36	1990 ± 249	1469 ± 184	2790 ± 349	2059 ± 257	3350 ± 419	2472 ± 309
M 39	2570 ± 257	1897 ± 190	3610 ± 361	2664 ± 266	4330 ± 433	3196 ± 320
M 42	3193 ± 319	2356 ± 471	4487 ± 449	3312 ± 331	5382 ± 538	3972 ± 397
M 45	3994 ± 399	2947 ± 589	5610 ± 561	4140 ± 414	6731 ± 673	4968 ± 497
M 48	4817 ± 482	3555 ± 711	6778 ± 678	5002 ± 500	8120 ± 812	5993 ± 599

* Dry Assembly

SERVICE RECOMMENDATIONS

Torque Marking – Basic Process

1. Tighten all bolts in the joint to a low torque or a snug torque.
2. Mark bolt head corner to abutment.

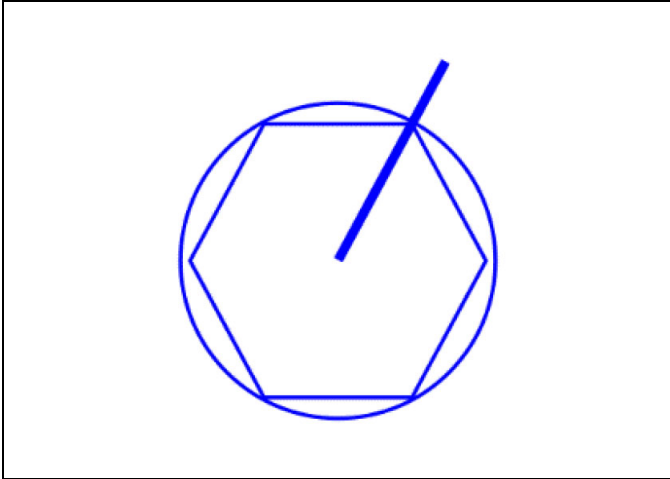

Figure 10-208

g06223465

3. Tighten bolt to specified torque.
4. Verify that the lines are broken.

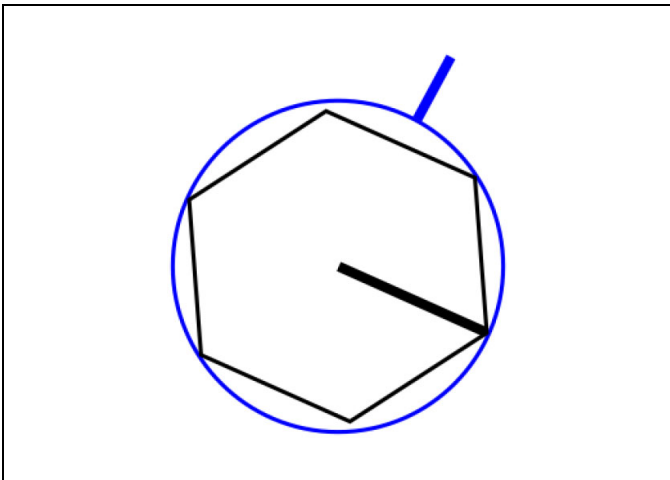

Figure 10-209

g06223468

Torque Marking – Circular Process

1. Tighten all bolts in the joint to a low torque or a snug torque.

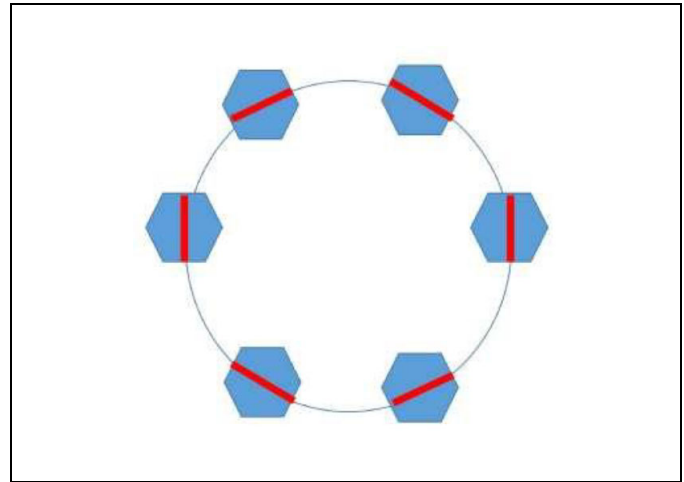

Figure 10-210

g06223470

2. Tighten bolt to specified torque.
3. Verify that the lines are no longer in a circular pattern.

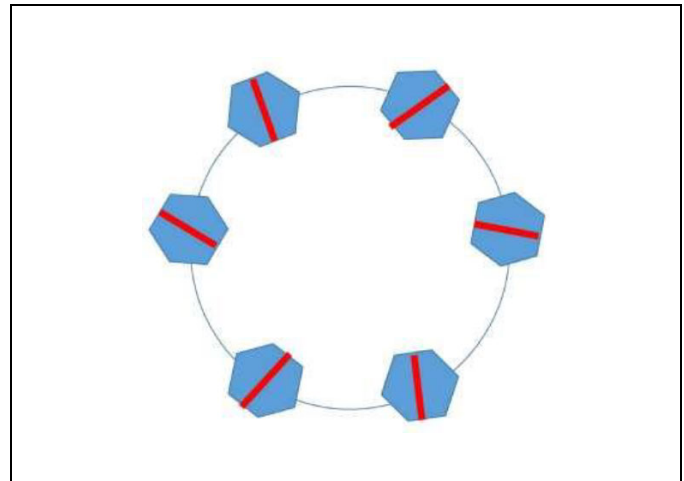

Figure 10-211

g06223472

Torque-Turn

The torque-turn method is used when precise control over clamping force is required. There is an initial torque and an additional turn. The initial torque is required to bring all parts of the joint into contact. The additional turn provides the desired clamping force. Ensure that all fasteners have been torqued before you perform the additional turns. Turn the fastener according to the specified amount. The specified amount will normally be equal to or greater than 90°. The specified amount will normally be in 30° increments. Turns of 120° or 180° are preferred. Turns of 120° or 180° are easily measured by the points of the hex head of the fastener. Lubrication may be specified in order to reduce the effort that is required for the final turn.

1. Tighten the fastener to the initial torque.
2. Mark a line on the fastener and on the abutment.

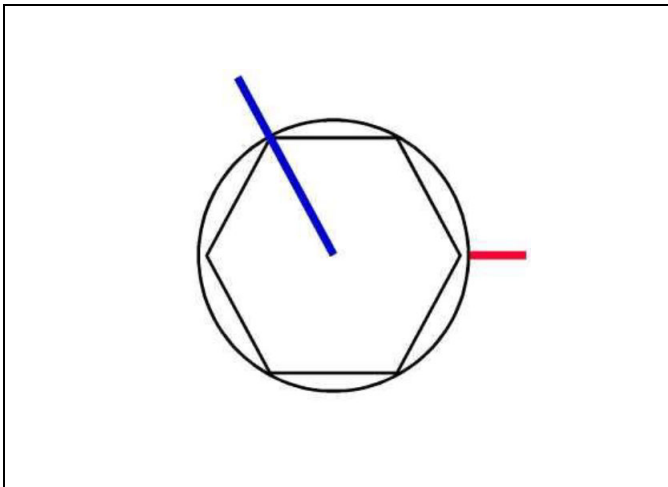

Figure 10-212

g06241021

3. Mark another line in a different color at the required angle on the abutment. (Example of 120° torque angle used for images)
4. Turn the fastener to the appropriate torque angle.

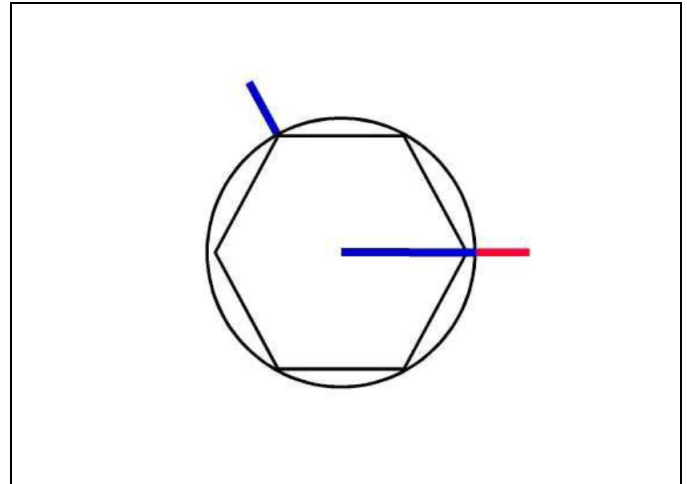

Figure 10-213

g06241028

NOTE: Marking the socket and aligning the mark on the socket with the original starting mark can aid in turning the fastener to the correct angle.

5. Verify the mark on the fastener is in-line with the torque angle mark.

SERVICE RECOMMENDATIONS

O-Ring Specifications

O-Ring Face Seal (ORFS) fittings incorporate an O-ring at the face of the fitting to prevent leaks in high pressure hydraulic systems.

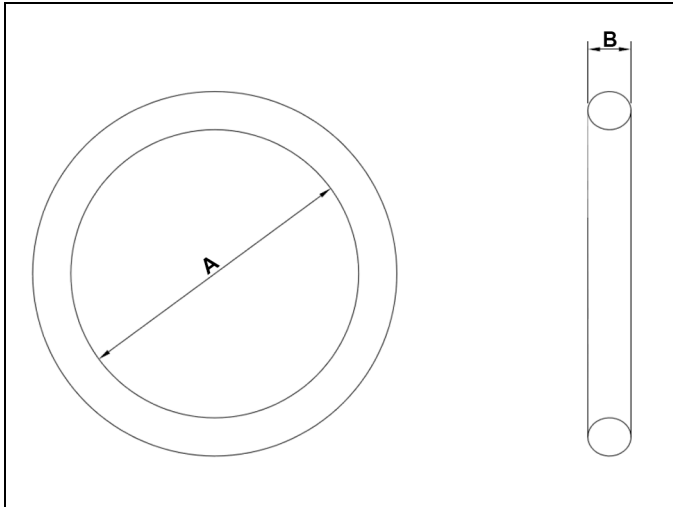

Figure 10-214

0000211

Use the following table for replacing O-ring face seal fittings:

Parker Hydraulics ID #	DASH Size #	Thread Size	A Dimension	B Dimension
2-011	4	9/16 in. - 18	7.65 mm (0.30 in.)	1.78 mm (0.7 in.)
2-012	6	11/16 in. -16	9.25 mm (0.36 in.)	1.78 mm (0.7 in.)
2-014	8	13/16 in. -16	12.42 mm (0.49 in.)	1.78 mm (0.7 in.)
2-016	10	1 in. -14	15.60 mm (0.61 in.)	1.78 mm (0.7 in.)
2-018	12	1 3/16 in. -12	18.77 mm (0.74 in.)	1.78 mm (0.7 in.)
2-021	16	1 7/16 in. -12	23.52 mm (0.93 in.)	1.78 mm (0.7 in.)
2-025	20	1 11/16 in. -12	29.87 mm (1.18 in.)	1.78 mm (0.7 in.)
2-029	24	2 in. -11	37.82 mm (1.49 in.)	1.78 mm (0.7 in.)

Hydraulic Pressure Specifications

⚠️ WARNING

Hydraulic relief valves limit system pressure to protect components. All hydraulic system relief valves work by balancing the hydraulic force with an adjustable spring force.

- The hydraulic valves may only be adjusted by qualified personnel.
- The hydraulic system must be depressurized before work can be performed on the system.
- If valves are not set properly or monitored carefully using proper gauges, the hydraulic system can malfunction and be damaged.

Failure to follow these warnings may result in serious injury or damage to the machine.

Use the following table to check and set hydraulic system pressures:

Component	Pressure (Bar)	Pressure (PSI)
Tilt Cylinders	340 – 360	4900 – 5200
Boom Cylinders	340 – 360	4900 – 5200
Rotary Pressure	340 – 360	4900 – 5200
Main Winch Maximum Pressure	340 – 360	4900 – 5200
Crowd Cylinder Up Pressure	280 – 320	4000 – 4600
Crowd Cylinder Down Pressure	280 – 320	4000 – 4600
Undercarriage	310 – 320	4500 – 4600
Head Mast Cylinder, Detent, and Rotary Cylinder	200 – 220	2900– 3200

Hydraulic and Electrical Schematics

Hydraulic and electrical schematics are separate publications. Contact CZM for these publications.

(*) M0080149-08 ©2022 Caterpillar All Rights Reserved

SERVICE RECOMMENDATIONS

Index

A

Above and Below Ground Hazards	7-14
Access Doors	
Engine Hood	10-3
Engine Service	10-4
Left Front	10-4
Left Rear	10-4
Right Side	10-4
Accumulator Safety	2-20
Aerosol Starting Aid	
Safety Decal	2-12
A-Frame	
Description	1-8
Installation	10-35
Removal	10-34
Air Conditioner	
Safety Decal	2-15
Air Conditioning	
Clean Condenser	10-85
Filter Inspect and Replace	10-85
Replace Receiver/Dryer	10-86
Alternate Exit*	
Safety Decal	2-11
Application Menu*	6-41
Authorized Use	2-38
Auxiliary Winch	
Add Oil	10-22
Check Oil Level	10-22
Description	1-10
Maintenance	10-22
Safety Information	2-46

B

Barge Safety	2-49
Base	
Description	1-5
Battery and Battery Cables	2-26
Battery Safety	2-23

C

Cab	10-88
Air Recirculation Filter Inspect and Replace	10-85
Clean Decals	10-89
Description	1-6
Fill Washer Reservoir	10-89
Fresh Air Filter Replacement	10-86
ROPS Inspection	10-87
Seat Belt	10-87
Cab Door*	7-1
Cab overview	6-3
Cat® myEquipment Mobile Application*	7-25
Clean Windows	10-88
Condenser (Refrigerant)	
Clean	10-87
Cooling System Coolant	
Change	10-87
Extender	10-52
Level Check	10-53
Level 2 Sample	10-55
Sample	10-53
Counterweight	
Installation	10-39
Removal	10-38
Counterweights	
Description	1-5
Critical Failures*	2-52
Crowd Cylinder	
Description	1-8
Crushing Hazard	
Safety Decal	2-13
Crushing Prevention and Cutting Prevention ...	2-22

D

Decal	
Cleaning	10-97
Decals	
Additional Safety	2-14
Safety	2-5
DEF Manifold Filters	
Replace	10-62
DEF Purge Indicator Lamp	
Safety Decal	2-14

Diesel Exhaust Fluid	
Clean Filler Screen	10-61
Drain	10-62
Fill	10-63
Filter Replacement	10-64
Replace Filter	10-63
Replace Fluid Injector	10-65
Replace Manifold Filters	10-62
Diesel Fuel Requirements	
Safety Decal	2-16
Dimensions	
Rotary Head	4-4
Dipstick	
Engine Ground Level	10-42
Engine Oil	10-41
Disconnect the Battery	2-26
Doors	
Engine Service	10-4
Left Front Access	10-4
Left Rear Access	10-4
Right Front Access	10-5
Right Side Access	10-5
Drilling Rig	
Components	1-2
General Description	1-1
Drilling rig Stability and Ground Pressure	
Safety Information	2-42

E

EK125 Standard Mast Version	5-1
Electrical Implements	
Description	1-15
Electrical Power Lines*	
Safety Decal	2-10
Electrical System Cleaning	
Safety	2-26
Electrical System Maintenance	
Safety	2-26
Emergency Exit	
Alternate Exit	2-34

Engine	
Dipstick	10-41
Ground Level Dipstick	10-41
Oil and Filter Change	10-42
Oil Level	10-41
Oil Level Check	10-97
Oil Sample	10-42
Engine Air Pre-Cleaner	
Clean	10-48
Engine Hood	10-3
Engine Oil Requirements	
Safety Decal	2-15
Engine Service Door	10-4
Engine Starting	
Safety	2-36

F

Final Drive	
Oil Change	10-97
Oil Level Check	10-98
Oil Sample	10-99
Fire Prevention and Explosion Prevention	2-23
Fire Safety	2-28
Fluid Penetration	
Safety	2-20
Fluid Systems	2-17
Fluids and Lubricants	10-11
Fuel System	
Primary Filter Replacement	10-58
Prime	10-99
Secondary Filter Replace	10-59
Water Separator Drain	10-60
Fuel Tank	
Clean Strainer	10-60
Drain	10-61
Fuel Transfer Pump (Refueling) (If Equipped)*	6-62
Fumes Disposal Filter Element	
Replace	10-80
Function Levers	6-9
Fuses	
Replace	10-80
Secondary Power Fuse Module	10-83

G			
Gauges			
Main and auxiliary pump	6-14		
H			
Hand Signals	2-37		
Hazard Prevention	2-17		
Head Mast			
Description	1-8		
High Intensity Discharge Lamp (HID)			
Replace	10-84		
High-Pressure Gas			
Safety Decal	2-13		
Hot Surface			
Safety Decal	2-11		
Hydraulic	10-11		
Clean Drain Filter	10-71		
Clean Tank Screen	10-69		
Fluids	10-11		
Oil Fill	10-71		
Oil Sample	10-76		
Pressure Specifications	10-105		
Purge Air	10-71		
Replace Return Filter	10-73		
Hydraulic Implements			
Description	1-13		
Hydraulic Lockout Control*	6-7		
Hydraulic System			
Hydraulic Oil Level Check Safety Decal	2-16		
J			
Job Site Safety	2-40		
Joysticks	6-10		
Left Joystick	6-10, 6-11		
Right Joystick	6-10, 6-12		
Jump-Start Cables			
Safety Decal	2-12		
K			
		Kelly Bar	
		Description	1-12
		Options	4-3
		Kelly Bar and Auger Safety	2-48
L			
		Left Front Access Door	10-4
		Left Rear Access Door	10-4
		Lines, Tubes, and Hoses	
		Safety	2-28
		Lockout/Tagout Procedure	2-51
		Long Mast Traveling Stability	
		Forward Facing	3-2
		Lubricants and Fluids	10-11
		Lubrication	
		Fluids and Lubricants	10-11
		Machine Lubrication Points	10-13
M			
		Machine Safety	
		Authorized Use	2-38
		Unauthorized Modifications	2-38
		Unauthorized Use	2-38
		Machine Security System*	7-18
		Machine Setup	
		Attach the Work Tool	8-3
		Extend the Undercarriage Tracks	8-2
		Place the Mast in the Work Position	8-3
		Machine Setup Steps for Drilling	8-1
		Machine Setup Steps for Transport	9-1
		Machine Warnings*	6-33
		Main Winch	
		Check Oil Level	10-20
		Description	1-9
		Maintenance	10-20
		Maintenance	
		Interval Schedule	10-7
		Plan	10-7
		Preparing For Maintenance	10-5
		Mast	
		Description	1-7

Mast Raising/Lowering Safety Information	2-45
Mast Tilting	5-5
Monitor	6-14
Active Faults Screen	6-28
Change Password Screens	6-25
Complete Maintenance Screens	6-26
First screen	6-16
Home screen	6-16
Initial Screen	6-14
Machine Settings Screen	6-18
Mast Level Calibration Screen	6-25
More settings screen	6-24
Settings Screen	6-27
Third screen	6-23
Monitoring System*	6-29
Mount and Dismount the Machine Safety	2-2

N

Navigation*	6-41
No Step Safety Decal	2-14

O

Oil Level	
Auxiliary Winch	10-22
Engine	10-41
Main Winch	10-20
Rotary Gearbox	10-26
Rotary Head	10-23
Oil Sample	
Engine Oil	10-42
Final Drive	10-99
Hydraulic Oil	10-76
Swing Drive	10-92
Oil Specifications	10-11
Open Hole Safety Information	2-47
Operation Starting the Machine	7-14
Operator Screen*	6-41
O-Ring Specifications	10-104

P

Pressurized Air and Water*	2-20
Product Link*	2-9
Purge Air From Hydraulic System	10-71

Q

Quick Reference Guide Controls	7-14
---	-------------

R

Radio*	6-38
Receiver Dryer	10-77
Relieve Hydraulic Tank Pressure Safety Decal	2-13
Right Side Access Door	10-4
Rotary Description	1-11
Rotary Drive	
Adjust Wear Pads	10-37
Rotary Gearbox Maintenance	10-26
Rotary Head Reducer Maintenance	10-23
Sled Wear Pad Replacement	10-36

S

Safety	
Battery	2-23
Decals	2-5, 2-14
Fire	2-38
General	2-1
Job Site	2-40
Machine	2-37
Maintenance	2-50
Operator	2-1
Transportation and Lifting	2-39

Screens	
Active Faults Screens	6-28
Change Password Screens	6-25
Complete Maintenance Screens	6-26
First Screen	6-16
Home Screen	6-15
Initial Screen	6-14
Machine Settings Screen	6-18
Mast Level Calibration Screen	6-25
Second Screen	6-19
Settings Screen	6-27
Third Screen	6-23
Seat Belt	
Inspect	10-87
Replace	10-88
Seat Belt*	2-9
Secondary Power Fuse Module	10-83
Severe Service	
Environment	10-2
Improper Maintenance	10-3
Operating Conditions	10-2
Signal Person	2-37
Spin-Off Safety Zone	2-47
Stability	
Auxiliary Winch Forward Facing	3-5, 3-11
Auxiliary Winch-Forward Facing	3-6, 3-7, 3-12
Drilling-Off the Side	3-5, 3-11
Traveling-Off the Side	3-3, 3-9
Starting the Machine	7-14
Swing Drive Oil	
Change	10-90
Level Check	10-92
Sample	10-92
Swing Gear	
Lubricate	10-93
Swing Operation	
Safety	2-44
Swivel	
Remove and Install	10-36
Symbols	
Description	1-17

T

Technical Specifications	
Auxiliary Winch	4-1
Crowd System	4-1
Diesel Engine CAT@330	4-2
General Data	4-2
Hydraulic System	4-2
Kelly Bar Short Mast Applications	4-1
Main Winch	4-1
Mast Inclination	4-1
Rotary Head - RT406 - 10 (Standard)	4-1
Torque Diagrams	4-5
Transport	4-2
Undercarriage	4-2
Torque Diagrams	4-5
Torque Tables	10-99
Track Adjustment	
Inspect	10-95
Inspect	10-97
Traffic Operation Safety	
	2-49
Transport	
Diagonal Lashing*	9-7
Disconnect the Work Tool	9-1
Frictional and Direct Lashing*	9-6
Lifting the Machine*	9-7
Place the Mast in Position	9-2
Retract the Undercarriage	9-3
Securing the Machine*	9-4
Tying Down the Machine*	9-5
Trapped Pressure	
Safety	2-20
Travel control levers	6-8
Traveling Down Hill	
Safety Information	2-43
Traveling Up Hill	
Safety Information	2-43
Traversing Slopes	
Safety Information	2-44

U

Unauthorized Modifications	2-38
Unauthorized Use	2-38
Undercarriage	
Description	1-4
Unstable or Uneven Terrain	
Safety Information	2-42
Safety Information	2-42

V

Vapor Explosion	
Safety Decal	2-13

W

Wear Pad	
A-Frame Replacement	10-37
Rotary Sled Replacement	10-36
Winch	
Auxiliary Maintenance	10-22
Main Maintenance	10-20
Wind Speed	2-38
Window Wiper	10-89
Wire Rope	
Lubrication	10-19
Maintenance	10-19
Replace	10-19
Wiring	
Safety	2-27

Page Intentionally Left Blank



FOUNDATION EQUIPMENT

▲ THE COMPANY

CZM is headquartered in Savannah, Georgia, USA. For over 40 years, we have specialized in manufacturing foundation equipment. We design and customize models for many different drilling applications including Drill shafts, CFA/Cased CFA, Micropile and anchoring, piledrive and hydraulic hammers and soil improvements. We are a Caterpillar OEM (Original Equipment Manufacturer).

HEADQUARTERS

962 Interstate Centre Boulevard
Ellabell • Georgia • 31308
United States • Phone: (912) 200-7654

AFTER SALES - CALIFORNIA

1720 North Ventura Avenue
Ventura • California • 93001
United States • Phone: (805) 701-9885

AFTER SALES - GEORGIA

145 East Industrial Boulevard
Pembroke • Georgia • 31321
United States • Phone: (912) 200-7656

AFTER SALES - TEXAS

2501 Blue Mound Rd. W
Haslet • Texas • 76052
United States • Phone: (817) 232-8053

WWW.CZM-US.COM