

A large, stylized red graphic consisting of several overlapping, sharp-edged shapes that resemble a stylized letter 'A' or a similar symbol, positioned in the upper left quadrant of the cover.

EK125

OPERATION AND MAINTENANCE MANUAL

CZM FOUNDATION EQUIPMENT

HEADQUARTERS

962 Interstate Centre Boulevard
Ellabell, Georgia 31308 United States
Phone: (912) 200-7654

AFTER SALES - CALIFORNIA

1720 North Ventura Avenue
Ventura, California 93001 United States
Phone: (805) 701-9885

AFTER SALES - GEORGIA

145 East Industrial Boulevard
Pembroke, Georgia 31321 United States
Phone: (912) 200-7656

AFTER SALES - TEXAS

2501 Blue Mound Rd. W
Haslet, Texas 76052 United States
Phone: (817) 232-8053

Manual code: OM10860.0017.000

Publication date July,2024

@2022 by CZM USA CORP. All rights reserved. No part of this manual may be reproduced, stored in a filing system, or transmitted to third parties in any form or by any means without CZM USA CORP prior written authorization.

CZM USA CORP reserves the right to make changes and improvements to its products at any time and without notice to constantly increase their quality; therefore, this Publication may also be subjected to future changes.

It is forbidden to operate the machine without reading and understanding the contents of this manual.

Special acknowledgment to: M0068104-14 ©2021

Caterpillar All Rights Reserved

CAT, CATERPILLAR, LET'S DO THE WORK, their respective logos, "Caterpillar Corporate Yellow", the "Power Edge" and Cat "Modern Hex" trade dress as well as corporate and product identity used herein, are trademarks of Caterpillar and may not be used without permission.

* M0068104-14 ©2021 Caterpillar All Rights Reserved

Original instructions in the English language.

SCAN THE QR CODE TO ACCESS CZM WEB PORTAL AND DOWNLOAD YOUR MANUALS.



Table of Contents

1. FOREWORD	19
1.1. IDENTIFICATIONS	20
1.1.1. MACHINE ID	20
1.1.2. MANUAL ID	20
1.2. ABOUT THE MANUFACTURER	21
1.2.1. CONTACT INFORMATION	21
1.3. ABOUT THIS MANUAL	22
1.3.1. USE AND PURPOSE	22
1.3.2. REPRODUCTION	22
1.3.3. CHANGES AND UPDATES	22
1.3.4. STORAGE	22
1.3.5. UNIT OF MEASURE	23
1.3.6. LANGUAGE	23
1.3.7. HAZARD ALERTS	23
1.4. WARRANTY TERMS	24
1.4.1. GENERAL CONDITIONS	24
1.4.2. THE MACHINES	24
1.4.3. THE PARTS	24
1.4.4. EXCLUSION CLAUSE	25
1.5. CALIFORNIA PROPOSITION 65 WARNING	26
2. INTRODUCTION	27
2.1. DESCRIPTION OF A DRILLING RIG	28
2.1.1. INTENDED USE	28
2.1.2. OPTIONAL USES	29
2.1.3. IMPROPER USE	29
2.1.3.1. DURING DRILLING	30
3. TECHNICAL INFORMATION	31
3.1. DESCRIPTION OF THE EK125	32
3.1.1. SERIAL NUMBER	32
3.1.2. IDENTIFICATION PLATE	32
3.1.3. ORIENTATION OF THE MACHINE	33
3.1.4. DESCRIPTION OF MAIN COMPONENTS	34
3.1.4.1. UNDERCARRIAGE	36
3.1.4.2. COUNTERWEIGHTS	38
3.1.4.3. BASE	39
3.1.4.4. CAB	41
3.1.4.5. PARALLELOGRAM	43
3.1.4.5.1. UPPER ARM	44
3.1.4.5.2. LOWER ARM	44
3.1.4.5.3. TRIANGULAR ELEMENT	44
3.1.4.5.4. BOOM CYLINDERS	44
3.1.4.5.5. TILTING CYLINDERS	44
3.1.4.6. MAST	45
3.1.4.6.1. MAIN MAST	45
3.1.4.6.2. UPPER MAST	46
3.1.4.6.3. MAST DETENT	46
3.1.4.7. MAST HEAD	47

3.1.4.8. A-FRAME	47
3.1.4.9. CROWD CYLINDER	48
3.1.4.10. MAIN WINCH	49
3.1.4.11. AUXILIARY WINCH	50
3.1.4.12. ROTARY	51
3.1.4.13. KELLY BAR	53
3.1.5. DESCRIPTION OF HYDRAULIC IMPLEMENTS	55
3.1.5.1. MAIN CAT PUMPS	56
3.1.5.2. AUXILIARY PISTON PUMP	56
3.1.5.3. COOLING PUMP	56
3.1.5.4. MAIN CAT CONTROL VALVE	56
3.1.5.5. AUXILIARY PROPORTIONAL CONTROL VALVE	57
3.1.5.6. REGENERATIVE SYSTEM MANIFOLD	57
3.1.5.7. SOLENOID MANIFOLD	57
3.1.5.8. 3-SPOOL VALVE	57
3.1.5.9. MAIN WINCH MANIFOLD	57
3.1.5.10. AUXILIARY WINCH MANIFOLD	57
3.1.5.11. ROTARY MANIFOLD	57
3.1.5.12. DRAIN RETURN FILTERS	58
3.1.5.13. PUMP GAUGES	58
3.1.5.14. HYDRAULIC TANK	58
3.1.5.15. HEAT EXCHANGER	58
3.1.6. DESCRIPTION OF ELECTRICAL IMPLEMENTS	59
3.1.6.1. POWER SUPPLY BOX	60
3.1.6.2. BASE CONTROLLER	60
3.1.6.3. BASE OUTPUT EXPANSION MODULE	60
3.1.6.4. COOLING CONTROLLER	60
3.1.6.5. SIGNAL CONDITIONING MODULE	60
3.1.6.6. CABIN CONTROLLER	60
3.1.6.7. AUXILIARY JOYSTICKS	61
3.1.6.8. CZM MONITOR	61
3.1.6.9. PUMP P1 PRESSURE SENSOR	61
3.1.6.10. RETURN TO CENTER SENSOR	61
3.1.6.11. RETURN FILTER SENSOR	61
3.1.6.12. MAST CONTROLLER	61
3.1.6.13. MAST OUTPUT EXPANSION MODULE	61
3.1.6.14. PRESSURE SENSORS	62
3.1.6.15. MAIN WINCH DEPTH SENSOR	62
3.1.6.16. MAST SLOPE SENSOR	62
3.1.6.17. MAST LIGHTS	62
3.1.6.18. MAIN WINCH LIMIT SWITCH	62
3.1.6.19. AUXILIARY WINCH LIMIT SWITCH	62
3.1.6.20. RPM SENSOR	63
3.1.7. DESCRIPTION OF SYMBOLS	64
4. SAFETY	65
4.1. GENERAL CONSIDERATIONS	66
4.2. PERSONNEL	67
4.2.1. PERSONNEL WITH DUTY OF CONSULTATION	67
4.2.1.1. MACHINE OPERATOR	67
4.2.1.1.1. OPERATOR'S DUTIES	67
4.2.1.1.2. OPERATOR'S TASKS	67

4.2.1.1.3. OPERATOR'S REQUIREMENTS	67
4.2.1.2. OPERATOR ASSISTANT	68
4.2.1.3. CZM TECHNICIAN	68
4.2.1.4. SPECIALIZED TECHNICIAN	68
4.2.2. OPERATIVE PERSONNEL	68
4.2.3. SIGNAL PERSON AND HAND SIGNALS	69
4.2.4. PERSONAL PROTECTIVE EQUIPMENT (PPE)	69
4.3. SAFETY MESSAGES*	70
4.3.1. SEAT BELT*	70
4.3.2. STANDARD SAFETY MESSAGES	71
4.3.2.1. HOT SURFACE (9)*	71
4.3.2.2. AEROSOL STARTING AID (10)*	72
4.3.2.3. JUMP-START CABLES (11)*	72
4.3.2.4. HIGH-PRESSURE GAS (12)*	73
4.3.2.5. VAPOR EXPLOSION (14)*	73
4.3.2.6. CRUSHING HAZARD (15)*	74
4.3.2.7. RELIEVE HYDRAULIC TANK PRESSURE (16)*	74
4.3.2.8. FALLING OBJECT GUARD STRUCTURE (17)*	75
4.3.3. ADDITIONAL SAFETY MESSAGES	75
4.3.3.1. NO STEP (8)*	76
4.3.3.2. DEF PURGE INDICATOR LAMP (9)*	76
4.3.3.3. AIR CONDITIONER (10)*	77
4.3.3.4. ENGINE OIL REQUIREMENTS (11)*	78
4.3.3.5. DIESEL FUEL REQUIREMENTS (12)*	78
4.3.3.6. HYDRAULIC OIL LEVEL CHECK (13)	78
4.4. HAZARD PREVENTION	79
4.4.1. HEALTH AND FIRST AID	79
4.4.1.1. CONTACT WITH FLUIDS	79
4.4.1.2. ELECTROCUTION	80
4.4.2. PRESSURIZED LINES*	80
4.4.2.1. FUEL LINES*	80
4.4.2.2. ACCUMULATORS	81
4.4.2.3. TRACK*	82
4.4.2.4. AIR AND WATER*	82
4.4.2.5. TRAPPED PRESSURE*	83
4.4.2.6. FLUID PENETRATION*	83
4.4.2.7. CONTAINING FLUID SPILLAGE*	84
4.4.3. INHALATION*	84
4.4.3.1. EXHAUST	84
4.4.3.2. ASBESTOS	84
4.4.3.3. HEXAVALENT CHROMIUM INFORMATION*	85
4.4.4. CRUSHING AND CUTTING*	85
4.4.5. BURN*	86
4.4.5.1. COOLANT	86
4.4.5.2. OILS	86
4.4.5.3. BATTERIES	87
4.4.6. FIRE AND EXPLOSION*	87
4.4.6.1. REGENERATION*	88
4.4.6.2. FUELING*	88
4.4.6.3. BATTERY AND BATTERY CABLES*	89
4.4.6.4. WIRING*	89

4.4.6.5. ETHER*	90
4.4.6.6. FIRE EXTINGUISHER	90
4.4.6.7. IN CASE OF FIRE	92
4.4.7. ELECTRICAL STORM INJURY*	92
4.4.8. SNOW AND ICE	93
4.4.9. DUST	93
4.4.10. CHEMICALS	93
4.4.11. SUSPENDED LOADS AND FALLING OBJECTS	94
4.5. WORK AREA	95
4.5.1. GENERAL RULES	95
4.5.2. OVERHEAD AND UNDERGROUND OBSTACLES	95
4.5.2.1. DISTANCE FROM POWER LINES	95
4.5.2.1.1. UNITED STATES SAFETY DISTANCE	96
4.5.3. SOIL CONDITIONS	97
4.5.3.1. SOIL CLASSIFICATION	97
4.5.3.2. SOIL SUBSIDENCE	98
4.5.3.3. SLOPES AND DITCHES	98
4.6. OPERATION AND USE OF THE DRILLING RIG	100
4.6.1. ACCESS TO THE DRILLING RIG	100
4.6.2. WORKPLACE	101
4.6.2.1. EMERGENCY EXIT	102
4.6.2.1.1. REAR WINDOW WITH RING SEAL (IF EQUIPPED)*	102
4.6.2.1.2. REAR WINDOW WITH LEVER (IF EQUIPPED)*	102
4.6.2.2. GUARDS	103
4.6.3. BEFORE STARTING THE ENGINE	103
4.6.3.1. MACHINE FAILURE	104
4.6.4. BEFORE OPERATION (ENGINE STARTED)	104
4.6.5. OPERATION	105
4.6.5.1. AUXILIARY WINCH	105
4.6.5.2. KELLY BAR	106
4.6.5.3. TRAVELING	107
4.6.5.4. CRITICAL FAILURES*	107
4.6.6. ENGINE STOPPING*	110
4.7. ASSEMBLING AND DISASSEMBLING	111
4.8. TRANSPORTATION	112
4.8.1. LOADING AND UNLOADING	112
4.8.2. LIFTING	113
4.9. MAINTENANCE	114
4.9.1. BEFORE PERFORMING MAINTENANCE	114
4.9.2. DURING MAINTENANCE	114
4.9.3. MOVING PARTS PRECAUTIONS	115
4.9.4. WELDING PRECAUTIONS	115
4.9.5. ENGINE AND REFUELING SYSTEM PRECAUTIONS	115
4.9.6. UNDERCARRIAGE PRECAUTIONS	116
4.9.7. ELECTRICAL SYSTEM PRECAUTIONS	116
4.9.7.1. BATTERIES	117
4.9.7.2. ELECTRICAL SYSTEM CLEANING	117
4.9.8. HYDRAULIC SYSTEM PRECAUTIONS	117
4.9.9. AIR CONDITIONING SYSTEM PRECAUTIONS	117
4.9.10. CLEANING THE DRILLING RIG	118
4.10. ENVIRONMENTAL PROTECTION	119

5. TECHNICAL SPECIFICATIONS	121
5.1. TECHNICAL DATA	122
5.1.1. KELLY BAR STANDARD MAST APPLICATION	122
5.1.2. KELLY BAR SHORT MAST APPLICATION	122
5.1.3. CROWD SYSTEM	122
5.1.4. ROTARY HEAD-STANDARD	123
5.1.4.1. DETAILED INFO	123
5.1.4.2. TORQUE DIAGRAM	123
5.1.4.3. SPIN-OFF DIAGRAM	124
5.1.5. ROTARY HEAD-OPTIONAL	125
5.1.5.1. DETAILED INFO	125
5.1.5.2. TORQUE DIAGRAM	125
5.1.5.3. SPIN-OFF DIAGRAM	126
5.1.6. MAST INCLINATION	126
5.1.7. MAIN WINCH	126
5.1.7.1. DETAILED INFO	127
5.1.8. AUXILIARY WINCH	127
5.1.8.1. DETAILED INFO	127
5.1.9. DIESEL ENGINE	128
5.1.10. COUNTERWEIGHT	128
5.1.11. HYDRAULIC SYSTEM	128
5.1.12. UNDERCARRIAGE	128
5.1.13. TRANSPORTATION	129
5.2. DIMENSIONS	130
5.2.1. STANDARD MAST VERSION	130
5.2.1.1. OVERALL DIMENSIONS	130
5.2.1.2. DIMENSIONS WITH SMALL AUGER	131
5.2.1.3. DIMENSIONS WITH LARGE AUGER	132
5.2.1.4. TRANSPORT DIMENSIONS	133
5.2.2. SHORT MAST VERSION	134
5.2.2.1. OVERALL DIMENSIONS	134
5.2.2.2. DIMENSIONS WITH SMALL AUGER	135
5.2.2.3. DIMENSIONS WITH LARGE AUGER	136
5.2.2.4. TRANSPORT DIMENSIONS	137
5.2.3. COMPONENTS	138
5.2.3.1. ROTARY	138
5.3. STABILITY AND GROUND PRESSURE	139
5.3.1. STANDARD MAST VERSION	140
5.3.1.1. TRAVELING - FORWARD FACING	140
5.3.1.2. TRAVELING - OFF THE SIDE	142
5.3.1.3. DRILLING - FORWARD FACING	144
5.3.1.4. DRILLING - OFF THE SIDE	146
5.3.1.5. AUXILIARY WINCH - FORWARD FACING TILTED	148
5.3.1.6. AUXILIARY WINCH - OFF THE SIDE TILTED	150
5.3.2. SHORT MAST VERSION	152
5.3.2.1. TRAVELING - FORWARD FACING	152
5.3.2.2. TRAVELING - OFF THE SIDE	154
5.3.2.3. DRILLING - FORWARD FACING	156
5.3.2.4. DRILLING - OFF THE SIDE	158
5.3.2.5. AUXILIARY WINCH - FORWARD FACING TILTED	160
5.3.2.6. AUXILIARY WINCH - OFF THE SIDE TILTED	162

5.4. DANGER ZONES	164
5.4.1. TRAVELING-VERTICAL MAST	164
5.4.2. TRAVELING-HORIZONTAL MAST	166
5.4.3. OPERATION-DRILLING	168
5.4.4. OPERATION-SPIN-OFF	169
5.4.5. OPERATION-MACHINE STOPPED	170
5.4.6. TRANSPORTATION	171
5.5. LIMITS OF USE	172
5.5.1. SOUND AND VIBRATION	173
5.5.1.1. SOUND LEVEL	173
5.5.1.2. VIBRATION	173
5.5.2. AUXILIARY WINCH	174
5.5.3. TRAVELING UP HILL	176
5.5.4. TRAVELING DOWN HILL	177
5.5.5. TRAVERSING SLOPES	178
5.5.6. SWING	179
5.5.7. MAST RAISING/LOWERING	180
5.5.8. MAST INCLINATION	181
5.5.9. ENVIRONMENTAL LIMITS	182
5.5.9.1. WIND	182
6. CONTROLS	183
6.1. ABOUT CONTROLS	184
6.2. CONTROLS OVERVIEW	185
6.3. BATTERY DISCONNECT SWITCH*	186
6.4. PUMP GAUGES	188
6.5. CAB OVERVIEW	189
6.5.1. OPERATOR SEAT*	191
6.5.1.1. ADJUSTMENT AND OPERATION*	192
6.5.1.2. SEAT BELT*	193
6.5.1.2.1. FASTENING THE SEAT BELT	193
6.5.1.2.2. RELEASING THE SEAT BELT	194
6.5.1.2.3. EXTENSION OF THE SEAT BELT	194
6.5.2. HYDRAULIC LOCKOUT CONTROL*	195
6.5.3. ENGINE START SWITCH*	196
6.5.4. TRAVEL CONTROLS	197
6.5.5. FUNCTION LEVERS	199
6.5.6. LEFT JOYSTICK	201
6.5.7. RIGHT JOYSTICK	203
6.5.8. RIGHT SIDE SWITCH PANEL*	205
6.5.8.1. ENGINE SPEED/POWER MODE CONTROL (10)*	205
6.5.8.1.1. ENGINE SPEED CONTROL	205
6.5.8.1.2. POWER MODE CONTROL	206
6.5.8.2. LIGHT SWITCH (11)*	206
6.5.8.3. WINDOW WASHER (12)	206
6.5.8.4. OPERATOR INFORMATION (13)*	206
6.5.8.5. JOG DIAL (14)*	206
6.5.8.6. AIR CONDITIONING AND HEATING (15)*	206
6.5.8.7. NEXT MENU (16)*	206
6.5.8.8. TRAVEL ALARM MUTE SWITCH (17) (IF EQUIPPED)*	207
6.5.8.9. HOME (18)*	207
6.5.8.10. RADIO CONTROL (19)*	207

6.5.8.11. RADIO MUTE (20)*	207
6.5.8.12. WINDOW WIPER (21)*	207
6.5.8.13. TRAVEL SPEED CONTROL (IF EQUIPPED) (22)*	207
6.6. CZM MONITOR	209
6.6.1. STARTING	209
6.6.2. HOME SCREEN	210
6.6.3. HOME SCREEN SWITCH FUNCTIONS	212
6.6.4. HOME SCREEN SETTINGS	214
6.6.5. SECOND SCREEN	216
6.6.6. SECOND SCREEN SWITCH FUNCTIONS	216
6.6.6.1. L1–MAIN WINCH LIMIT AND EXCLUSION SWITCH	217
6.6.6.2. L2–AUXILIARY WINCH LIMIT AND EXCLUSION SWITCH	218
6.6.6.3. L3–MAIN WINCH BOTTOM HOLE EXCLUSION SWITCH	219
6.6.6.4. R1–MAST LOCK SWITCH (IF EQUIPPED)	220
6.6.7. SECOND SCREEN SETTINGS	221
6.6.8. THIRD SCREEN	223
6.6.8.1. THIRD SCREEN-PAGE 1 SWITCH FUNCTIONS	224
6.6.8.1.1. L1–MAIN WINCH AUTO-SHIFT	224
6.6.8.1.2. L2–MAIN WINCH DOWNSHIFT	224
6.6.8.1.3. L3–POWER SHIFT	224
6.6.8.1.4. R1–ROTARY AUTO-SHIFT	224
6.6.8.1.5. R2–SWING ALARM	225
6.6.8.1.6. R3–DISPLAY UNITS	225
6.6.8.2. THIRD SCREEN-PAGE 2 SWITCH FUNCTIONS	225
6.6.8.2.1. L1-MAST LEVEL CALIBRATION	225
6.6.8.2.2. L3–CROWD LIMIT OVERRIDE	226
6.6.8.2.3. R1-PASSWORD CHANGE	226
6.6.8.2.4. R2–COMPLETE MAINTENANCE	227
6.6.9. SETTINGS SCREEN	229
6.6.10. ACTIVE FAULTS SCREENS	231
6.7. CAT MONITORING SYSTEM*	232
6.7.1. GENERAL INFORMATION*	233
6.7.1.1. ACTION LAMPS (1)*	234
6.7.1.2. STATUS INFORMATION AREA (2)*	234
6.7.1.2.1. MULTI STATUS INFORMATION (2A)*	235
6.7.1.2.2. SEATBELT SWITCH STATUS (IF EQUIPPED) / POWER MODE (2B)*	235
6.7.1.3. NOTIFICATION CENTER ICON (3)*	236
6.7.1.4. CAMERA VIEW (4)*	236
6.7.1.4.1. 360 VISIBILITY (IF EQUIPPED)*	237
6.7.1.5. GAUGE AREA (5)*	237
6.7.1.6. NAVIGATION BAR (6)*	238
6.7.2. MACHINE WARNINGS*	238
6.7.3. LOGGING IN*	239
6.7.4. NAVIGATION*	239
6.7.4.1. OPERATOR INFORMATION BUTTON (1)*	240
6.7.4.2. JOG DIAL (2)*	240
6.7.4.3. AIR CONDITIONER BUTTON (3)*	240
6.7.4.4. NEXT MENU BUTTON (4)*	240
6.7.4.5. HOME BUTTON (5)*	240
6.7.4.6. AUDIO BUTTON (6)*	240
6.7.4.7. MUTE BUTTON (7)*	240

6.7.5. RADIO*	240
6.7.5.1. RADIO FUNCTION LIST*	243
6.7.5.2. SELECTION METHOD*	243
6.7.5.3. RADIO OPERATION*	244
6.7.5.4. USB/AUX OPERATION*	244
6.7.6. AIR CONDITIONING AND HEATING CONTROL*	244
6.7.6.1. SELECTION METHOD*	247
6.7.6.2. OPERATION*	248
7. OPERATION	249
7.1. BEFORE OPERATION	250
7.1.1. DAILY INSPECTIONS	250
7.1.2. MOUNTING AND DISMOUNTING	250
7.1.3. CAB OPERATION	250
7.1.3.1. CAB DOOR*	250
7.1.3.2. WINDOW (FRONT)*	251
7.1.3.3. ROOF HATCH*	253
7.1.3.4. SUN SCREEN*	253
7.1.3.5. DOME LIGHT*	254
7.1.4. VISIBILITY	255
7.1.4.1. MIRRORS*	255
7.1.4.1.1. MIRROR ADJUSTMENT*	256
7.1.4.1.1.1. RIGHT SIDE VIEW MIRROR ON THE CAB (1)*	257
7.1.4.1.1.2. LEFT SIDE VIEW MIRROR ON THE CAB (4)*	257
7.1.4.1.1.3. TANK MIRROR (3)*	257
7.1.4.2. CAMERAS*	259
7.1.4.2.1. REAR VIEW CAMERA*	259
7.1.4.2.2. RIGHT SIDE VIEW CAMERA (IF EQUIPPED)*	259
7.1.4.2.3. 360 VISIBILITY (IF EQUIPPED)*	260
7.1.5. FUEL TRANSFER PUMP (REFUELING) (IF EQUIPPED)*	261
7.1.5.1. FUEL TANK SHUTOFF AND DRAIN CONTROL*	262
7.1.6. OPERATION INFORMATION*	263
7.1.6.1. UNDERCARRIAGE	263
7.1.6.1.1. TRAVELING	263
7.1.6.2. BASE SWINGING	264
7.1.6.3. PARALLELOGRAM	264
7.1.6.4. WINCHES	264
7.1.6.4.1. MAIN WINCH	265
7.1.6.4.2. AUXILIARY WINCH	265
7.2. STARTING THE MACHINE	266
7.2.1. SELECTIVE CATALYTIC REDUCTION WARNING SYSTEM*	266
7.2.1.1. DEFINITIONS*	266
7.2.1.2. INDUCEMENT STRATEGY FOR DEF LEVEL*	267
7.2.1.3. INDUCEMENT STRATEGY FOR DEF QUALITY, TAMPERING, SCR SYSTEM FAULT, AND IMPEDED EGR*	268
7.2.2. MACHINE SECURITY SYSTEM*	270
7.2.2.1. GENERAL INFORMATION*	270
7.2.2.2. COMPONENTS*	271
7.2.2.3. SYSTEM OVERVIEW*	271
7.2.2.4. ACTIVATING BLUETOOTH FUNCTIONALITY*	271
7.2.2.5. PAIRING YOUR DEVICE TO THE MACHINE*	272
7.2.2.6. READING THE ID OF A KEY*	273

7.2.2.7. ARMED*	273
7.2.2.8. DISARMED*	273
7.2.2.9. GRACE PERIOD*	273
7.2.2.10. NAVIGATING THE USER INTERFACE TOUCHSCREEN DISPLAY*	274
7.2.2.11. OPERATION OF STATUS INDICATOR*	275
7.2.2.12. OPERATOR LOGIN*	275
7.2.2.12.1. PASSCODE ENTRY*	276
7.2.2.12.1.1. INVALID PASSCODE*	277
7.2.2.12.1.2. BYPASS LOGIN*	277
7.2.2.12.2. BLUETOOTH ENTRY*	277
7.2.2.12.3. CAT @FLEET MANAGEMENT MOBILE APPLICATION*	279
7.2.2.12.3.1. MOBILE DEVICE/OPERATING SOFTWARE COMPATIBILITY*	279
7.2.2.12.3.2. MOBILE APPLICATION ENTRY (ANDROID DEVICES)*	279
7.2.2.12.3.3. MOBILE APPLICATION ENTRY (IOS DEVICES)*	283
7.2.3. ENGINE STARTING*	286
7.2.4. ENGINE START SWITCH TROUBLESHOOTING*	288
7.2.5. ENGINE AND MACHINE WARM-UP*	289
7.2.5.1. HYDRAULIC SYSTEM AUTOMATIC WARM-UP*	289
7.2.5.2. HYDRAULIC SYSTEM MANUAL WARM-UP*	290
7.2.5.3. IMPROVE COLD-WEATHER PERFORMANCE*	290
7.2.5.3.1. RECOMMENDATION FOR CRANKCASE BREATHER PROTECTION (MACHINES WITH C4.4 AND C7.1)*	291
7.2.5.3.2. INSTALLATION*	291
7.2.6. ENGINE STARTING (ALTERNATE METHODS)*	292
7.2.6.1. ENGINE STARTING WITH JUMP START CABLES (IF EQUIPPED)*	292
7.2.6.2. ENGINE STARTING WITH AUXILIARY START RECEPTACLE (IF EQUIPPED)*	293
7.3. MACHINE SETUP FOR DRILLING	295
7.3.1. FORWARD AND REVERSE TRAVEL	295
7.3.2. TURNING	296
7.3.3. EXTEND THE UNDERCARRIAGE TRACKS	297
7.3.4. PLACE THE MAST IN THE WORK POSITION	298
7.3.5. CONNECT THE WORK TOOL	301
7.4. DRILLING OPERATIONS	303
7.4.1. STANDARD DRILLING	303
7.4.2. AUTOMATIC DRILLING FUNCTIONS	306
7.4.2.1. AUTO DRILL (DRILL LOCK)	306
7.4.2.2. AUTO CROWD	306
7.4.2.3. AUTO MAST LEVEL	307
7.4.2.4. RETURN TO CENTER	307
7.4.2.5. ROTARY AUTO-SHIFT	308
7.4.2.6. MAIN WINCH AUTO-SHIFT	309
7.4.2.7. AUTO POWER SHIFT (SPIN-OFF)	309
7.4.2.8. OVERCROWD PROTECTION SYSTEM	310
7.4.2.9. BOTTOM HOLE SYSTEM	310
7.4.3. DRILLING ON ROCK (BOULDERS)	311
7.4.4. DRILLING ON SLURRY/POLYMER OR BENTONITE	312
7.4.5. INSTALLING A CASING	312
7.4.5.1. J-LOCK CASING	313
7.4.5.2. SEGMENTED CASING	314
7.5. STOPPING THE MACHINE	315
7.5.1. PARKING*	315

7.5.2. STOPPING THE ENGINE*	315
7.5.3. ENGINE SHUTDOWN SWITCH*	316
7.5.4. STOP THE ENGINE IF AN ELECTRICAL MALFUNCTION OCCURS*	316
7.5.5. LEAVING THE MACHINE*	317
7.6. MACHINE STORAGE	318
7.6.1. FOR A SHORT PERIOD OF TIME	318
7.6.2. FOR A LONG PERIOD OF TIME	318
7.7. DECOMMISSIONING AND DISPOSAL*	319
8. ASSEMBLY	320
8.1. ASSEMBLING THE MACHINE'S COMPONENTS	321
8.1.1. CZM COUNTERWEIGHT (ADDITIONAL)	321
8.1.2. CAT COUNTERWEIGHT (MAIN)	322
8.1.3. ROTARY	324
8.1.4. SWIVEL	326
8.1.5. A-FRAME	327
8.1.6. KELLY BAR	328
8.1.6.1. STANDARD MAST VERSION	328
8.1.6.2. SHORT MAST VERSION	331
9. DISASSEMBLY	334
9.1. DISASSEMBLING THE MACHINE'S COMPONENTS	335
9.1.1. DISASSEMBLING THE KELLY BAR	335
9.1.1.1. STANDARD MAST VERSION	335
9.1.1.2. SHORT MAST VERSION	338
9.1.2. DISASSEMBLING THE A-FRAME	341
9.1.3. DISASSEMBLING THE SWIVEL	342
9.1.4. DISASSEMBLING THE ROTARY	343
9.1.5. DISASSEMBLING THE CZM COUNTERWEIGHT (ADDITIONAL)	344
9.1.6. DISASSEMBLING THE CAT COUNTERWEIGHT (MAIN)	345
10. CONVERSIONS	347
10.1. COMPONENTS' WEIGHTS	348
10.2. FROM STANDARD TO SHORT MAST	349
10.3. FROM SHORT TO STANDARD MAST	353
11. TRANSPORTATION	359
11.1. MACHINE SETUP FOR TRANSPORTATION	360
11.2. DISCONNECT THE WORK TOOL	361
11.3. PLACE THE MAST IN THE TRANSPORT POSITION	363
11.4. LOCK THE KELLY BAR	368
11.5. RETRACT THE UNDERCARRIAGE TRACKS	369
11.6. SHIPPING THE MACHINE*	370
11.7. SECURING THE MACHINE*	372
11.8. TYING DOWN THE MACHINE*	373
11.8.1. FRICTIONAL AND DIRECT LASHING*	373
11.8.2. DIAGONAL LASHING*	373
11.9. LIFTING THE MACHINE*	375
11.10. CENTER OF GRAVITY	376
12. MAINTENANCE	377
12.1. MAINTENANCE RECOMMENDATIONS	378

12.1.1. WELDING ON MACHINES AND ENGINES WITH ELECTRONIC CONTROLS*	379
12.1.2. SEVERE SERVICE APPLICATION*	379
12.1.2.1. SEVERE ENVIRONMENTAL FACTORS*	379
12.1.2.2. SEVERE OPERATING CONDITIONS*	379
12.1.2.3. IMPROPER MAINTENANCE PROCEDURES (MAINTENANCE PROCEDURES WHICH MAY CONTRIBUTE TO A SEVERE SERVICE APPLICATION)*	380
12.2. ACCESS DOOR AND HOOD LOCATIONS*	381
12.2.1. ENGINE HOOD*	381
12.2.2. ENGINE SERVICE DOOR*	382
12.2.3. LEFT REAR ACCESS DOOR*	382
12.2.4. LEFT FRONT ACCESS DOOR*	382
12.2.5. RIGHT SIDE ACCESS DOOR*	382
12.2.6. RIGHT FRONT ACCESS DOOR*	383
12.3. PREPARE THE MACHINE FOR MAINTENANCE*	384
12.4. MAINTENANCE PLAN	386
12.4.1. WHEN REQUIRED	387
12.4.1.1. MACHINE BASE	387
12.4.2. EVERY 10 HOURS OR DAILY	389
12.4.2.1. MACHINE BASE	389
12.4.2.2. ROTARY AND ROTARY GUIDE	389
12.4.2.3. MAIN AND AUXILIARY WINCH	390
12.4.2.4. HYDRAULIC SYSTEM	390
12.4.3. EVERY 50 HOURS OR WEEKLY	391
12.4.3.1. PARALLELOGRAM AND MAST COMPONENTS	391
12.4.3.2. ROTARY AND ROTARY GUIDE	391
12.4.3.3. MAIN AND AUXILIARY WINCH	391
12.4.3.4. KELLY BAR AND A-FRAME	392
12.4.3.5. HYDRAULIC SYSTEM	392
12.4.4. EVERY 250 HOURS OR MONTHLY	393
12.4.4.1. MACHINE BASE	393
12.4.4.2. PARALLELOGRAM AND MAST COMPONENTS	393
12.4.4.3. ROTARY AND ROTARY GUIDE	393
12.4.4.4. MAIN AND AUXILIARY WINCH	394
12.4.5. EVERY 500 HOURS OR QUARTERLY	395
12.4.5.1. MACHINE BASE	395
12.4.5.2. ROTARY AND ROTARY GUIDE	395
12.4.6. EVERY 1000 HOURS OR ANNUALLY	396
12.4.6.1. MACHINE BASE	396
12.4.6.2. ROTARY AND ROTARY GUIDE	396
12.4.6.3. MAIN AND AUXILIARY WINCH	396
12.4.6.4. HYDRAULIC SYSTEM	397
12.4.6.5. KELLY BAR	397
12.4.7. EVERY 2000 HOURS	398
12.4.7.1. MACHINE BASE	398
12.4.8. EVERY YEAR	398
12.4.8.1. MACHINE BASE	398
12.4.9. EVERY 5000 HOURS	398
12.4.9.1. MACHINE BASE	398
12.4.10. EVERY 6000 HOURS OR 3 YEARS	399
12.4.10.1. MACHINE BASE	399
12.4.11. EVERY 12000 HOURS OR 6 YEARS	399

12.4.11.1. MACHINE BASE	399
12.5. FLUIDS AND LUBRICANTS	400
12.5.1. RECOMMENDED FLUIDS AND LUBRICANTS	400
12.5.1.1. DIESEL FUEL RECOMMENDATIONS	400
12.5.1.2. DIESEL EXHAUST FLUID (DEF) RECOMMENDATIONS	400
12.5.1.2.1. MATERIALS COMPATIBILITY	401
12.5.1.2.2. BULK STORAGE	401
12.5.1.2.3. HANDLING	402
12.5.1.2.4. CLEANLINESS	402
12.5.1.2.5. STABILITY	402
12.5.2. REGULAR AMBIENT TEMPERATURE	403
12.5.3. COLD WEATHER	404
12.5.4. HOT WEATHER	404
12.6. LUBRICATING THE MACHINE	406
12.7. BASE MACHINE MAINTENANCE	414
12.7.1. ENGINE*	414
12.7.1.1. ENGINE OIL*	414
12.7.1.1.1. CHECKING THE ENGINE OIL LEVEL*	414
12.7.1.1.1.1. ENGINE DIPSTICK*	414
12.7.1.1.1.2. GROUND LEVEL DIPSTICK*	415
12.7.1.1.2. OBTAINING THE ENGINE OIL SAMPLE*	416
12.7.1.1.3. CHANGING THE ENGINE OIL AND FILTER*	416
12.7.1.1.3.1. SELECTION OF THE OIL CHANGE INTERVAL*	416
12.7.1.1.3.2. PROCEDURE FOR CHANGING ENGINE OIL AND FILTER*	417
12.7.1.1.3.3. FAST FILL (IF EQUIPPED)*	419
12.7.1.2. ENGINE AIR FILTER PRIMARY AND/OR SECONDARY ELEMENT*	420
12.7.1.2.1. REPLACING THE PRIMARY AIR FILTER ELEMENT*	421
12.7.1.2.2. REPLACING THE SECONDARY AIR FILTER ELEMENT*	422
12.7.1.2.3. CLEANING THE ENGINE AIR PRE-CLEANER*	423
12.7.1.3. FUMES DISPOSAL FILTER ELEMENT	425
12.7.1.3.1. REPLACING THE FUMES DISPOSAL FILTER ELEMENT*	425
12.7.1.4. COOLING SYSTEM COOLANT (ELC)*	426
12.7.1.4.1. CHANGING THE COOLING SYSTEM COOLANT (ELC)*	427
12.7.1.4.2. ADDING THE COOLING SYSTEM COOLANT EXTENDER (ELC)*	429
12.7.1.4.3. CHECKING THE COOLING SYSTEM COOLANT LEVEL*	430
12.7.1.4.4. OBTAINING THE COOLING SYSTEM COOLANT SAMPLE (LEVEL 1)*	430
12.7.1.4.5. OBTAINING THE COOLING SYSTEM COOLANT SAMPLE (LEVEL 2)*	431
12.7.1.5. BELT	432
12.7.1.5.1. INSPECTING/ADJUSTING/REPLACING THE BELT	432
12.7.2. FUEL SYSTEM*	433
12.7.2.1. REPLACING THE FUEL TANK CAP FILTER*	433
12.7.2.2. REPLACING THE FUEL LIFT PUMP STRAINER (IN-LINE FILTER)*	433
12.7.2.3. PRIMING THE FUEL SYSTEM*	434
12.7.2.4. REPLACING THE FUEL SYSTEM PRIMARY FILTER (WATER SEPARATOR) ELEMENT*	435
12.7.2.4.1. CAT 323	435
12.7.2.5. REPLACING THE FUEL SYSTEM SECONDARY FILTER*	438
12.7.2.5.1. CAT 323	438
12.7.2.6. DRAINING THE FUEL SYSTEM WATER SEPARATOR*	440
12.7.2.6.1. CAT 323, CAT 330	440
12.7.2.7. CLEANING THE FUEL TANK STRAINER*	441

12.7.2.8. DRAINING THE FUEL TANK WATER AND SEDIMENT*	442
12.7.2.9. DIESEL EXHAUST FLUID (DEF)*	442
12.7.2.9.1. CLEANING THE DEF FILLER SCREEN*	443
12.7.2.9.2. REPLACING THE DEF MANIFOLD FILTERS*	444
12.7.2.9.2.1. CAT 323 - CAT 330	444
12.7.2.9.3. DRAINING THE DEF*	444
12.7.2.9.4. FILLING THE DEF*	445
12.7.2.9.5. REPLACING THE DEF FILTER	446
12.7.2.9.5.1. CAT 323	446
12.7.2.9.6. REPLACING THE DEF INJECTOR*	449
12.7.3. HYDRAULIC SYSTEM*	450
12.7.3.1. RELEASING OF HYDRAULIC PRESSURE FROM THE MAIN HYDRAULIC SYSTEM*	450
12.7.3.2. CHANGING THE HYDRAULIC SYSTEM OIL*	451
12.7.3.3. CLEANING THE HYDRAULIC TANK SCREEN*	454
12.7.3.4. CLEANING THE CASE DRAIN FILTER*	456
12.7.3.5. PURGING AIR AND FILLING THE HYDRAULIC SYSTEM OIL*	456
12.7.3.6. REPLACING THE HYDRAULIC SYSTEM OIL FILTER (RETURN)*	459
12.7.3.7. CHECKING THE HYDRAULIC SYSTEM OIL LEVEL*	462
12.7.3.8. OBTAINING THE HYDRAULIC SYSTEM OIL SAMPLE*	464
12.7.3.8.1. CAT 323	464
12.7.3.9. TESTING INDICATORS AND GAUGES*	464
12.7.3.10. INSPECTING THE OIL FILTER FOR DEBRIS*	465
12.7.3.11. CLEANING THE RADIATOR, AFTERCOOLER AND OIL COOLER CORES*	465
12.7.3.12. REPLACING THE RECEIVER DRYER (REFRIGERANT)*	466
12.7.3.13. RETURN LINE FILTER	467
12.7.3.13.1. REPLACING THE RETURN FILTER ELEMENTS	467
12.7.4. ELECTRICAL SYSTEM*	467
12.7.4.1. BATTERY*	467
12.7.4.1.1. CLEANING THE BATTERY*	467
12.7.4.1.2. CHECKING THE BATTERY ELECTROLYTE LEVEL*	468
12.7.4.1.3. INSPECTING/REPLACING THE BATTERY OR BATTERY CABLE	468
12.7.4.1.4. TIGHTENING THE BATTERY HOLD-DOWN*	469
12.7.4.1.5. RECYCLING THE BATTERY	469
12.7.4.2. CAMERA*	469
12.7.4.2.1. CLEANING THE CAMERA*	469
12.7.4.3. FUSES AND RELAYS*	471
12.7.4.3.1. REPLACING THE FUSES*	471
12.7.4.3.2. FUSES DESCRIPTION*	472
12.7.4.3.3. RELAYS DESCRIPTION*	474
12.7.4.3.4. POWER FUSE MODULE*	474
12.7.4.3.5. SECONDARY POWER FUSE MODULE (IF EQUIPPED)*	475
12.7.4.4. HIGH INTENSITY DISCHARGE LAMP (HID)*	476
12.7.4.4.1. REPLACING THE HIGH INTENSITY DISCHARGE LAMP (HID) (IF EQUIPPED)*	476
12.7.4.5. LIGHT EMITTING DIODE LAMP (LED)*	477
12.7.4.5.1. REPLACING THE LIGHT EMITTING DIODE LAMP (LED)*	477
12.7.5. CAB	477
12.7.5.1. AIR CONDITIONER/CAB HEATER FILTER (RECIRCULATION)*	477
12.7.5.1.1. INSPECTING/REPLACING THE AIR RECIRCULATION FILTER ELEMENT*	477
12.7.5.2. CONDENSER (REFRIGERANT)*	478
12.7.5.2.1. CLEANING THE CONDENSER*	478
12.7.5.3. CAB AIR FILTER (FRESH AIR)*	479

12.7.5.3.1. CLEANING/REPLACING THE CAB AIR FILTER*	479
12.7.5.4. ROLLOVER PROTECTIVE STRUCTURE (ROPS)*	480
12.7.5.4.1. INSPECTING THE ROLLOVER PROTECTIVE STRUCTURE (ROPS)*	480
12.7.5.5. SEAT BELT*	480
12.7.5.5.1. INSPECTING THE SEAT BELT*	480
12.7.5.5.2. REPLACING THE SEAT BELT*	481
12.7.5.6. WINDOWS*	482
12.7.5.6.1. CLEANING THE WINDOWS*	482
12.7.5.6.1.1. CLEANING METHODS*	482
12.7.5.6.1.1.1. POLYCARBONATE WINDOWS (IF EQUIPPED)*	483
12.7.5.6.2. INSPECTING/REPLACING THE WINDOW WIPER*	483
12.7.5.6.3. FILLING THE WINDOW WASHER RESERVOIR*	483
12.7.6. ETHER STARTING AID CYLINDER (IF EQUIPPED)*	484
12.7.6.1. REPLACING THE ETHER STARTING AID CYLINDER*	484
12.7.7. DECALS	485
12.7.7.1. CLEANING THE DECALS	485
12.7.7.1.1. HAND WASHING	485
12.7.7.1.2. POWER WASHING	486
12.8. FRAME MAINTENANCE	487
12.8.1. LOWER FRAME	488
12.8.2. UPPER FRAME	489
12.9. SWING MAINTENANCE	490
12.9.1. LUBRICATING THE SWING BEARING*	490
12.9.2. CHANGING THE SWING DRIVE OIL*	490
12.9.3. CHECKING THE SWING DRIVE OIL LEVEL*	492
12.9.4. OBTAINING THE SWING DRIVE OIL SAMPLE*	492
12.9.5. LUBRICATING THE SWING GEAR*	493
12.10. UNDERCARRIAGE MAINTENANCE	496
12.10.1. CHECKING THE UNDERCARRIAGE*	496
12.10.2. CLEANING THE UNDERCARRIAGE*	496
12.10.3. TESTING THE TRAVEL ALARM*	496
12.10.4. TRACK*	497
12.10.4.1. MEASURING THE TRACK TENSION*	497
12.10.4.2. ADJUSTING THE TRACK TENSION*	498
12.10.4.2.1. TOOLING	499
12.10.4.2.2. SPECIFICATIONS	500
12.10.4.2.3. ADJUSTMENT PROCEDURE	501
12.10.4.3. INSPECTING THE TRACK ADJUSTMENT*	502
12.10.5. FINAL DRIVE*	502
12.10.5.1. CHANGING THE FINAL DRIVE OIL*	502
12.10.5.2. CHECKING THE FINAL DRIVE OIL LEVEL*	504
12.10.5.3. OBTAINING THE FINAL DRIVE OIL SAMPLE*	505
12.11. WIRE ROPES MAINTENANCE	506
12.11.1. INSPECTING THE WIRE ROPE	506
12.11.2. LUBRICATING THE WIRE ROPE	506
12.11.3. REPLACING THE WINCH WIRE ROPE	506
12.11.3.1. APPLYING WIRE ROPE TENSION	507
12.11.3.2. AFTER THE INSTALLATION OF A NEW ROPE	507
12.12. MAIN WINCH MAINTENANCE	508
12.12.1. CHECKING THE MAIN WINCH REDUCER/BRAKE OIL LEVEL	508
12.12.2. ADDING THE MAIN WINCH REDUCER/BRAKE OIL	509

12.12.3. DRAINING AND REFILLING THE MAIN WINCH REDUCER/BRAKE OIL	510
12.13. AUXILIARY WINCH MAINTENANCE	512
12.13.1. CHECKING THE AUXILIARY WINCH REDUCER/BRAKE OIL LEVEL	512
12.13.2. ADDING THE AUXILIARY WINCH REDUCER/BRAKE OIL	513
12.13.3. DRAINING AND REFILLING THE AUXILIARY WINCH REDUCER/BRAKE OIL	514
12.14. ROTARY MAINTENANCE	516
12.14.1. ROTARY REDUCER	516
12.14.1.1. CHECKING THE ROTARY REDUCER OIL	516
12.14.1.2. ADDING THE ROTARY REDUCER OIL	516
12.14.1.3. DRAINING AND REFILLING THE ROTARY REDUCER OIL	517
12.14.2. ROTARY CASING	518
12.14.2.1. CHECKING THE ROTARY CASING OIL	518
12.14.2.2. ADDING THE ROTARY CASING OIL	519
12.14.2.3. DRAINING AND REFILLING THE ROTARY CASING OIL	520
12.14.3. ROTARY SLED WEAR PADS	521
12.14.3.1. ADJUSTING THE ROTARY SLED WEAR PADS	521
12.14.3.2. REMOVING THE ROTARY SLED WEAR PADS	522
12.14.3.3. INSTALLING THE ROTARY SLED WEAR PADS	522
12.15. A-FRAME MAINTENANCE	524
12.15.1. REPLACING THE A-FRAME WEAR PADS	524
12.16. TORQUE SPECIFICATIONS	525
12.17. O-RING SPECIFICATIONS	527
12.18. HYDRAULIC PRESSURE SPECIFICATIONS	528
13. INDEX	529

This page is intentionally left blank.

1. FOREWORD

1.1. IDENTIFICATIONS

1.1.1. Machine ID

Table 1. Machine ID

Manufacturer:	CZM USA CORP
Designation:	Drilling rig
Type:	EK125
Model:	EK125.0017, EK125.0021
Serial Number:	
Year of Manufacture:	

1.1.2. Manual ID

Table 2. Manual ID

Code:	OM10860.0017.000
Version:	3.1.0
Publication Date:	Jul, 2024

1.2. ABOUT THE MANUFACTURER

CZM is headquartered in Savannah, Georgia, USA. For more than 40 years, we have specialized in manufacturing foundation equipment.

We design and customize models for many different drilling applications, including:

- Drilled Shafts;
- CFA;
- Cased CFA;
- Micro Pile;
- Anchoring;
- Piled Driving;
- Hydraulic Hammers;
- Soil Improvements.

1.2.1. Contact Information

CZM FOUNDATION EQUIPMENT

HEADQUARTERS

962 Interstate Centre Boulevard
Ellabell, Georgia 31308 United States
Phone: (912) 200-7654

AFTER SALES - CALIFORNIA

1720 North Ventura Avenue
Ventura, California 93001 United States
Phone: (805) 701-9885

AFTER SALES - GEORGIA

145 East Industrial Boulevard
Pembroke, Georgia 31321 United States
Phone: (912) 200-7656

AFTER SALES - TEXAS

2501 Blue Mound Rd. W
Haslet, Texas 76052 United States
Phone: (817) 232-8053

1.3. ABOUT THIS MANUAL

This manual comprises information, advice, and important warnings regarding the use of CZM equipment, to help to take full advantage of the technical qualities of the drilling rig.

The manufacturer will guarantee the basic operating features for the particular model.

Supplements to this manual will be made whenever required changes are made to the equipment.

It includes guidance on safety, direction for maintaining the drilling rig, and strategies for protecting the environment.



IMPORTANT

- Carefully read and understand this manual before operating or servicing this machine.
- All personnel involved with this machine should read and understand the information in this manual.

1.3.1. Use and Purpose

This manual includes instructions for the operation and maintenance of the machine in the expected operating conditions.

The manual, divided into logical and sectoral SECTIONS, is designed to inform and instruct the staff in charge of its tasks.

The machine must be used according to the instructions in the manual.



IMPORTANT

CZM USA CORP is not responsible for damage caused by failure to observe the instructions.

1.3.2. Reproduction

All information contained in this manual is protected by copyright law.

The reproduction, distribution and promotional use of the manual, or parts thereof, not expressly authorized by CZM USA CORP is prohibited.

No part of this manual may be reproduced, stored in an archive, or transmitted to third parties in any form and by any means without the prior written authorization of CZM USA CORP.

1.3.3. Changes And Updates

CZM USA CORP reserves the right to make changes and improvements to its products at any time and without notice, to continuously improve their quality.

The information contained in this manual is based on what was available at the time of compilation. Some texts and illustrations may not be faithful to the machine you own, without this giving rise to disputes.

At any time there may be variations relating to a particular version of the machine, even if the basic information remains unchanged and does not lose its validity.

Before starting any activity, you must ensure that you have all the necessary information with specific reference to the updates of the technical publications available.

The inconsistencies between what is written in the manual and the actual operation of the machine are attributable to a previous version of the machine compared to the drafting of the manual, or a manual awaiting adaptation to changes made to the machine.

1.3.4. Storage

This manual must be stored with care, even after reading, in an immediately accessible place inside the cabin, so that it can always be available for consultation or clarification.

In case of doubts or difficulties in understanding this manual, contact CZM USA CORP.

In case of loss or damage, request a copy from CZM USA CORP.

Any technical-informative communication sent by CZM USA CORP after delivery of the machine must be attached to the manual.

The manual must accompany the machine in case of resale.

1.3.5. Unit Of Measure

The British Imperial Measurement System is used in this manual.

The data expressed in the SI International Measurement System are conversions from the British Imperial Measurement System.

1.3.6. Language

The original instructions in this manual are in the English language.

Other languages must be considered a translation of the original instructions.

1.3.7. Hazard Alerts

Hazard alerts in this manual are used to alert operators, job supervisors, maintenance staff, and job site workers to hazardous operating practices and maintenance procedures.

Hazard alerts used throughout this manual contain a hazard-alert symbol and a signal word.

They identify the hazard's degree of consequence if the message is ignored.

ANSI/ISO signal words are used to warn of potentially hazardous situations that may lead to damage, personal injury, or even death.

Hazard alerts in this manual and on the machine and drilling rig decals use signal words or illustrations that are used to indicate the potential level of hazard.

The following hazard alerts are used in this manual:



DANGER

Indicates a hazardous situation that, if not avoided, will result in death or serious injury.



WARNING

Indicates a hazardous situation that, if not avoided, could result in death or serious injury.



CAUTION

Indicates a hazardous situation that, if not avoided, could result in injury.



IMPORTANT

Indicates important information that, if not observed, can cause damage to the machine and reduce its useful life.



NOTICE

Is used to address practices not related to personal injury.



ENVIRONMENTAL NOTICE

Environmental information is recommended to follow so that using the equipment doesn't harm the environment.

1.4. WARRANTY TERMS

The warranty period starts with the delivery of the equipment to the Customer and after a CZM Certified Technician, in charge of commissioning the equipment, certifies that:

- The CZM Certified Technician delivered the equipment to the operator and, upon delivery, it was inspected to ensure that all safety mechanisms and devices, safety and information plates were present, correctly affixed, or installed.
- The CZM Operation and Maintenance Manual was delivered to the Operator with the equipment.
- The Operator, and any other possible operator, have received appropriate training concerning the use of the equipment by a CZM Certified Technician.
- The Operator acknowledges and assumes full responsibility for the application of the instructions in the Operation and Maintenance Manual and the teachings of the CZM Certified Technician.
- The Customer and its employees are aware and acknowledge that it is the Customer's responsibility to provide adequate training to future operators, maintenance technicians, or workers who can operate the equipment, according to what is indicated in the Operation and Maintenance Manual and to the training received by the CZM Certified Technician.
- The Customer guarantees that every possible operator will use the equipment according to the intended use of the Manufacturer described in the Operation and Maintenance Manual.

1.4.1. General Conditions

- CZM USA CORP, the manufacturer of the equipment and tools branded CZM, ensures its products are sold against defects through its After Sales department.
- The transport expenses for the equipment or its components to the manufacturer's locations or authorized dealers are not included in the Warranty terms.
- If the user chooses to set up the machine in other places, the Warranty Terms do not include traveling expenses for service technicians. In this case, the After Sales department will submit a quote for these costs for customer approval.
- The responsibility of CZM or authorized dealer during the Warranty Period, or by civil contract or a result of warranties, declarations, instructions, or effects of any kind, shall be limited to repair or delivery parts, under the conditions mentioned in the Warranty Terms.
- The CZM USA CORP reserves the right at any time to revise, modify, or discontinue any products without the need to update the models that are already on the market.

1.4.2. The Machines

The After-Sales department or authorized dealer will service, repair, or replace any part or product that, according to technical analysis, fails by a defect in material or workmanship.

The workplace could be in a CZM branch, or the machine's current location, if possible.

The After Sales department will provide the labor for service needed at no cost to the user during the following periods after the date of delivery to the user:

- 12 (twelve) months: In the case of hydraulic motors, gearboxes, rotary transmission, axles, hydraulic components, and structural components.
- 6 (six) months: For other items, considered wear parts, including sealing components.

The Warranty Terms are subject to the execution of all the Maintenance Procedures described in the Operator Manual, as well as commissioning, performed by trained technicians designated by the manufacturer.

1.4.3. The Parts

The After-Sales department or authorized dealer will fix or repair any part that, according to technical analysis, fails by a defect in material or workmanship.

The workplace could be in a CZM branch, or the machine's current location, if possible.

The After Sales department will provide the labor for service needed at no cost to the user for the following periods after the date of delivery to the user:

- 3 (three) months: From the date of issue of invoice, if the user takes the responsibility of assembling the part.
- 6 (six) months: From the date of issuance of the Order of Service concerning the intervention, if the assembly is performed by an authorized service professional.

1.4.4. Exclusion Clause

The Warranty Terms do not apply in the case of:

- Improper use or maintenance, negligence, inability, or accident.
- Use of implements and/or parts not approved by CZM.
- Use of lubricants and oils not listed.
- Use of non-original spare parts.
- Products operated over the capacity it was designed for and/or recommended by the manufacturer.
- Products modified or repaired in a way not authorized by the manufacturer.
- Products whose preventive maintenance and inspections are not performed following the specifications contained in Operation and Maintenance Manual.
- Components having warranty cover with their respective manufacturers, such as excavator chassis, fuel injection components, diesel engines, etc.
- Normal-wear parts such as brake discs, wear plates, pins, lubricated joints (pins and bushings), or any parts that wear out due to contact with soil, oil, lubricants, filters, exhausts, and associated parts (injector nozzles, adjusters, straps, lenses, lamps, and fuses).



NOTICE

- Warranty does not cover economic losses due to nonoperational machine or rented equipment costs.
- Kelly bars wear with use and are extremely susceptible to damage due to operator error. This component will not be warranted unless the failure is deemed to be from manufacturing non-conformity.

1.5. CALIFORNIA PROPOSITION 65 WARNING

Diesel engine exhaust and some of its constituents are known to the State of California to cause cancer, birth defects, and other reproductive harm.



WARNING

This product can expose you to chemicals including ethylene glycol, which is known to the State of California to cause birth defects or other reproductive harm.

For more information go to:

www.P65Warnings.ca.gov

Do not ingest this chemical. Wash hands after handling to avoid incidental ingestion.



WARNING

This product can expose you to chemicals including lead and lead compounds, which are known to the State of California to cause cancer, birth defects, or other reproductive harm.

For more information go to:

www.P65Warnings.ca.gov

Wash hands after handling components that may contain lead.

2. INTRODUCTION

2.1. DESCRIPTION OF A DRILLING RIG

The machine described in this manual is a drilling rig. It is designed and built to be used in vertical drilling of the ground, to build foundation piles. For its operation, only one operator in the cabin is required, who must possess all the requirements for the safe operation and use of the machine. The drilling method used is rotary drilling. With rotary drilling, the clay or rock at the bottom of the hole is crushed or cut by a drilling tool that rotates and exerts a crowd force at the same time. Depending on the consistency of the soil, you can choose different tools that crush or cut the clay or rock by pressure, shear stress, or traction effort. The drilling tool is connected to the machine via a telescopic kelly bar. The rotation movement and the crowd force are transmitted to the telescopic kelly bar via a rotary head. To remove the excavated material from the hole, the tool is cyclically brought back to the surface, the turret is rotated and all the debris collected is discharged. The lifting and lowering of the tool are carried out using a winch (Main Winch). The drilling and discharging operations are repeated until the required depth is reached. When the hole is completed, a metal cage is inserted. Afterward, it is filled with concrete. The Auxiliary Winch can be used to lower the metal cage inside the hole.

2.1.1. Intended Use

The drilling rig is used to bore holes to create foundation piles.

The jobs that this drilling rig can carry out are:

- Rotary drilling on clayey soils.
- Rotary drilling on rocky soils.
- Insertion and extraction of casings.

The auxiliary winch must only be used to support work operations to handle the following objects:

- Kelly bars.
- Drilling tools.
- Casings.
- Reinforcements.
- Tremie Pipes.



IMPORTANT

Any other use than that described in this manual must be considered "PROHIBITED".

The instructions for using the machine, the working methods, and the limits provided are exclusively those specified in this manual.

If it is necessary to operate in particular conditions, other than those specified, contact CZM USA CORP before proceeding.



DANGER

It is forbidden to carry out works for which the machine has not been designed, this would lead to improper use of the machine, with serious consequences.

- Respect all the information and instructions written in this manual.
- Respect the national safety regulations in force.
- Make sure all safety devices are installed and functioning.
- Respect the performance limits of the machine.
- The use, maintenance, and repairs of the machine must be carried out by trained personnel with recognized skills.
- All accident prevention regulations and generally recognized standards for occupational safety and medicine must be respected.

**IMPORTANT**

CZM USA CORP is not liable for damage or accidents caused by the use of the drilling rig in conditions other than those written in this manual.

2.1.2. Optional Uses

The machine can be equipped with this optional equipment, supplied exclusively by CZM USA CORP:

- Short Mast Version for drilling with an overhead restriction.

**WARNING**

If the optional parts and accessories described in this manual are purchased at a later time, make sure you have the specific additional technical documentation.

If not, contact CZM USA CORP.

It is forbidden to use optional parts and accessories in the absence of specific documentation.

2.1.3. Improper Use

Improper use means any use of this machine that does not comply with the instructions contained in this manual and which, in any case, is dangerous for the operator and other people involved.

**DANGER**

Improper use of this machine is highly dangerous.

The manufacturer declines all responsibility for any damage to persons and/or property resulting from improper use of the machine.

**WARNING**

The drilling rig is intended to be used only as a drilling rig.

It is not a crane and must not perform crane operations.

Failure to follow this warning could result in death or serious injury.

The list shows some reasonably foreseeable cases of improper use of the machine:

- It is forbidden to use the machine for lifting generic loads.
- It is forbidden to use the machine or its parts to move, lift, or lower people.
- It is forbidden to use the machine by minors or inexperienced people.
- It is forbidden to use the machine for the transport of containers with flammable liquids or in any case considered dangerous.
- It is forbidden to use the machine in dark or low-light conditions.
- It is forbidden to use the machine or its parts to push or pull other objects or structures.
- It is forbidden to use the machine or its parts to tow or push vehicles.
- It is forbidden to use the machine to drill soils that require drilling technologies other than those that the machine is capable of using.
- It is forbidden to use the machine for leveling the soil.
- It is forbidden to use the machine in unstable ground conditions or in the presence of inadmissible slopes.
- It is forbidden to use the machine as a crane.
- It is forbidden to use the machine with drilling equipment not authorized by the manufacturer.
- It is forbidden to use the machine in environmental conditions different from those specified.
- It is forbidden to use the machine in environments with an explosive atmosphere and/or with a risk of fire.
- It is forbidden to use the machine if the scheduled maintenance plan has not been respected.
- It is forbidden to exceed the limited values of the machine.
- It is forbidden to move the machine in the working configuration with the undercarriage closed.

- It is forbidden to work with the undercarriage closed.
- It is forbidden to raise the mast with the undercarriage closed.

2.1.3.1. During Drilling

During drilling and in any case with the drilling equipment engaged in the hole, it is forbidden to:

- Move the machine with the undercarriage.
- Move the parallelogram.
- Move the mast.



WARNING

These operations can cause a deviation of the hole with consequent damage to the machine and the drilling equipment.



WARNING

It is strictly forbidden to use the parallelogram or the mast tilting cylinders to exert a force (crowd or pull up).

They must be used only for positioning.

3. TECHNICAL INFORMATION

3.1. DESCRIPTION OF THE EK125

The EK125 from CZM has been designed for high performance and to have the fastest and easiest setup from transport mode to operation. It is mounted on a Caterpillar (CAT) base to provide a reliable drilling rig in order to keep the operation and maintenance, friendly and efficient. This model is a compact drill rig that can be transported as one unit with an easy setup using self-erecting functions done from the cab. Therefore, the EK125 also has the versatility to be easily converted from standard to short mast by replacing the top mast assembly, crowd cylinder, and kelly bar. Hydraulic extendable crawlers on the base, additional counterweight, and a mast manufactured in Weldox®¹ steel (lightweight and high-yield strength) gives the EK125 excellent stability.

3.1.1. Serial Number

The serial number of the machine is located:

- on the Identification Plate (see “*Identification Plate*” (p. 32)).
- in this manual (see “*Machine ID*” (p. 20)).

3.1.2. Identification Plate

The identification plate of the machine is located on the front or lateral side of the toolbox.

Figure 1.



0000408 ID Plate

¹WELDOX is a trademark owned by the SSAB group of companies.

3.1.3. Orientation of the Machine

In this manual, the terms front, rear, left, and right refer to the direction of travel of the machine as seen from the operator's seat, with the operator facing forward and the drive wheel of the track at the rear.

The image is for illustration purposes and shows a generic machine without a mast.

Figure 2.

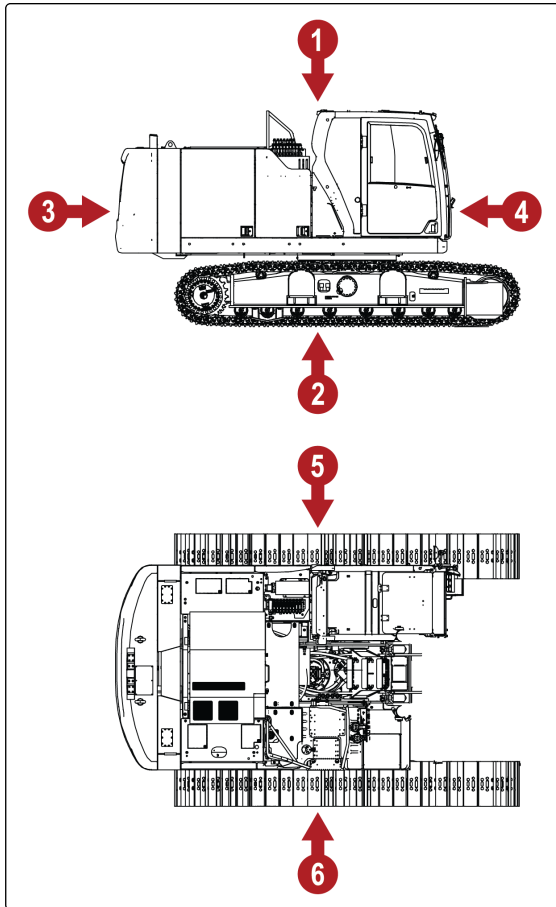

0000459 Machine Orientation

Pos.	Description
1	Upper
2	Lower
3	Rear
4	Front
5	Left
6	Right

3.1.4. Description of Main Components

Figure 3.

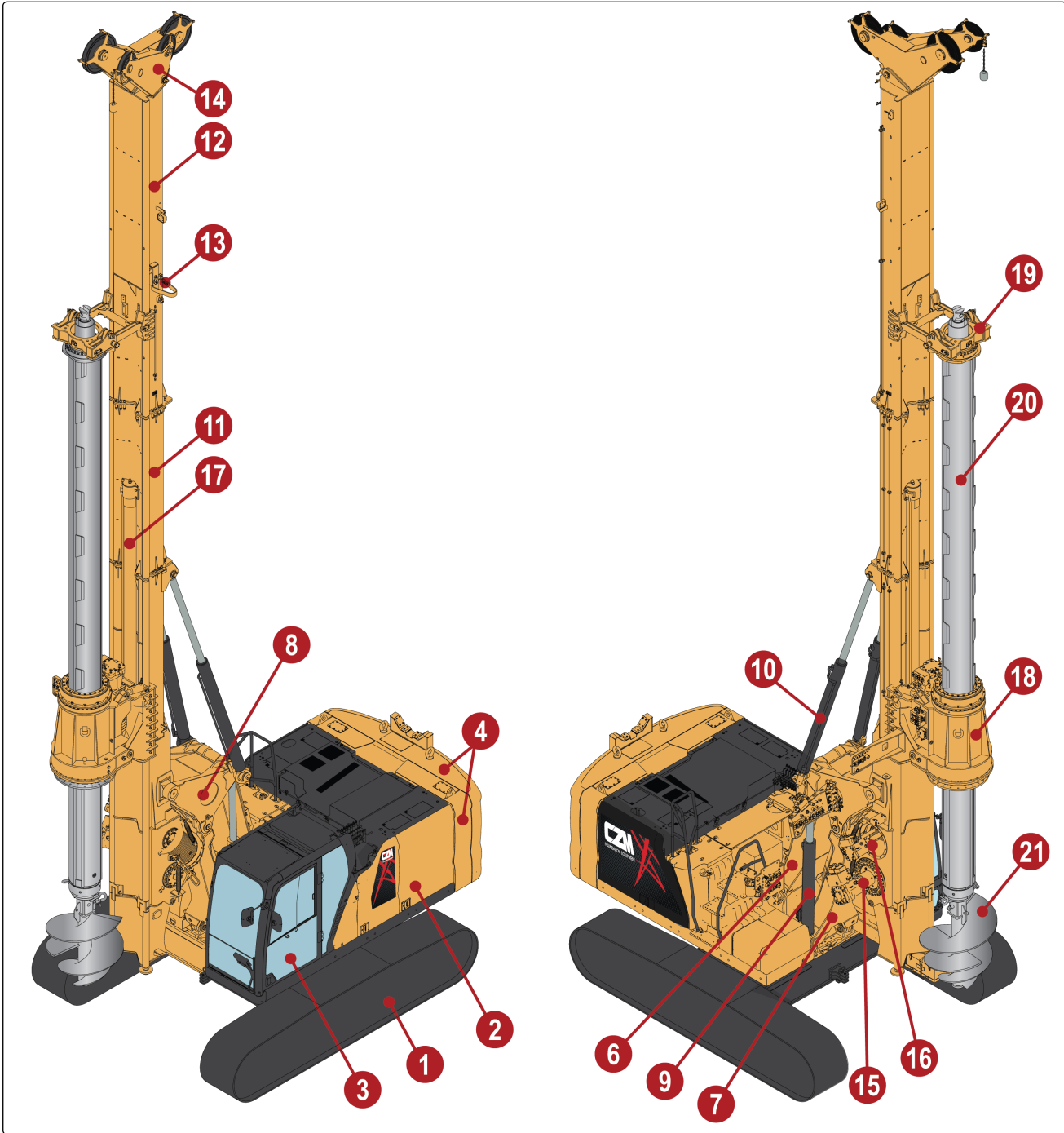

0000113.1 Main Components

Pos.	Description	Pg.
1	Undercarriage	36
2	Base (CAT)	39
3	Cab	41
4	Counterweights	38
6	Upper Arm	44
7	Lower Arm	44
8	Triangular Element	44
9	Boom Cylinders	44
10	Tilting Cylinders	44
11	Mast	45
12	Upper Mast	46
13	Mast Detent	46
14	Mast Head	47
15	Main Winch	49
16	Auxiliary Winch	50
17	Crowd Cylinder	48
18	Rotary	51
19	A-Frame	47
20	Kelly Bar	53
21	Tool	-

3.1.4.1. Undercarriage

Figure 4.

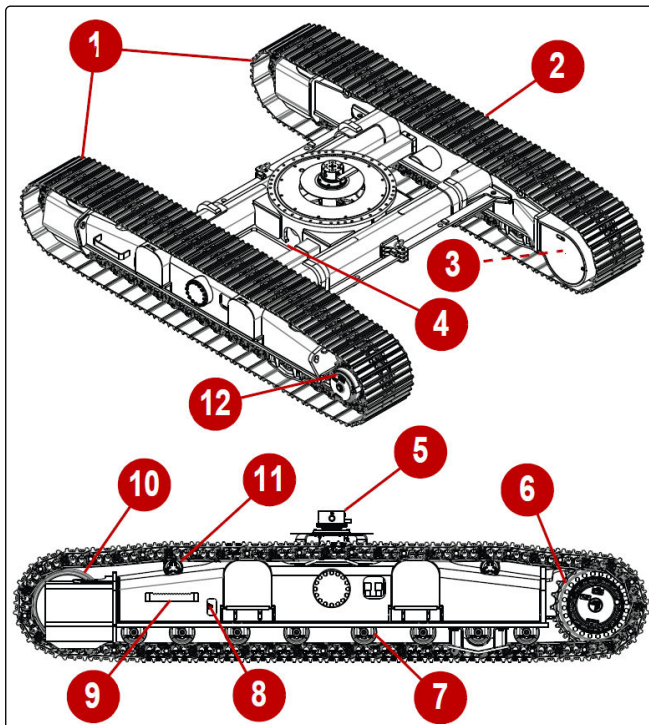

0000232 Undercarriage

Pos.	Description
1	Track Chain
2	Track Shoes
3	Track Motor And Valve
4	Undercarriage Cylinders
5	Undercarriage Swivel
6	Drive Wheel
7	Track Lower Rollers
8	Track Tensioner Greasing Point
9	Track Steps
10	Track Wheel
11	Track Upper Roller
12	Track Planetary Drive

The undercarriage of a drilling rig encompasses the tracks, track frame, and hydraulic motor and gearing. The undercarriage is part of the base of the machine. It is connected to the upperstructure at the swing bearing and the undercarriage swivel (5).

Cylinders inside the frame extend to push the side frames to expand and retract to pull them in.

The undercarriage includes the tracks consisting of:

- track chains (1).
- track links.
- pins.
- rollers.
- track shoes (2).

The track system also includes:

- track motor and valves (3).
- drive wheels (6).
- track lower rollers (7).
- track wheels (10).
- track upper rollers (11).
- track planetary drives (12).

The track motors and planetary drives are responsible for moving the machine on the job site.



IMPORTANT

For long distances, the machine should be trucked to reduce the wear on the track system.



IMPORTANT

Since the undercarriage literally supports the machine for all jobs it's important to maintain and take proper care of it. Failure to do so can lead to breakdowns and other mechanical problems that can take the machine off rotation.



IMPORTANT

Cleaning and removing any debris from the undercarriage after each shift will help keep all the moving parts functioning properly. This is especially important in cooler climates because frozen debris can cause wear to bolts, fasteners, and other connections in the undercarriage. There are many moving parts in this part of an excavator and keeping everything moving clear of debris is important.



IMPORTANT

Undercarriages should also be a standard part of daily inspections. Track shoes, chains, bolts, and tension as well as rock guards and track motors, and drive wheels should be checked every day.



NOTICE

Following best practices for driving and operating will also help to maintain the undercarriage of an excavator. Taking wide turns, minimizing time on slopes, using the proper grouser, avoiding harsh terrain, and minimizing excessive spinning will all help with the upkeep of an undercarriage.

3.1.4.2. Counterweights

Figure 5.

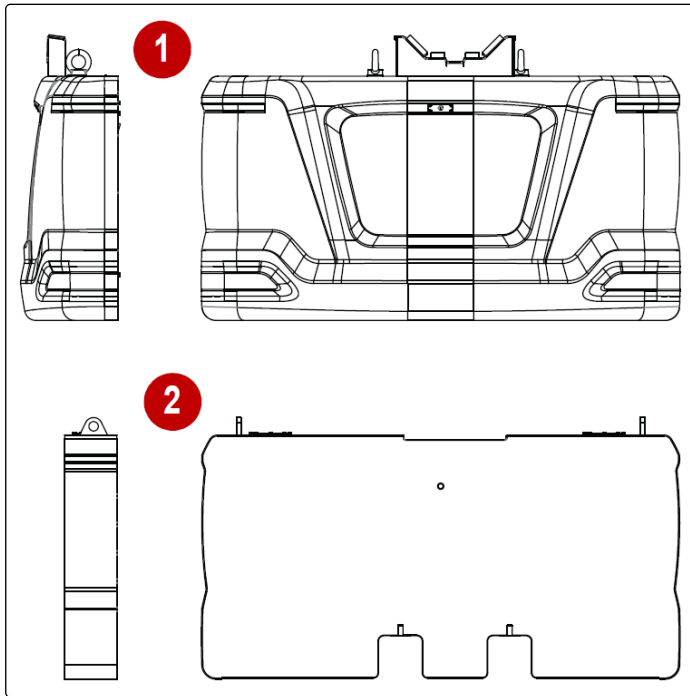

0000262 Counterweights

Pos.	Description
1	CAT Counterweight (Main)
2	CZM Counterweight (Additional)

This machine has 2 counterweights, attached to the back of the machine. They balance the drill rig's weight. The main CAT counterweight (1) and the additional counterweight (2) can both be optionally removed to reduce the transport weight.

Follow the conditions under which the machine can run without any counterweight safely.

⚠ WARNING

If disassembled for transport, counterweights must be assembled immediately after unloading the machine from the truck.

Follow the safe procedure to install and remove the counterweights.

For more information see:

- Section: "Assembling the Machine's Components" (page 321).
- Section: "Disassembling the Machine's Components" (page 335).

3.1.4.3. Base

Figure 6.

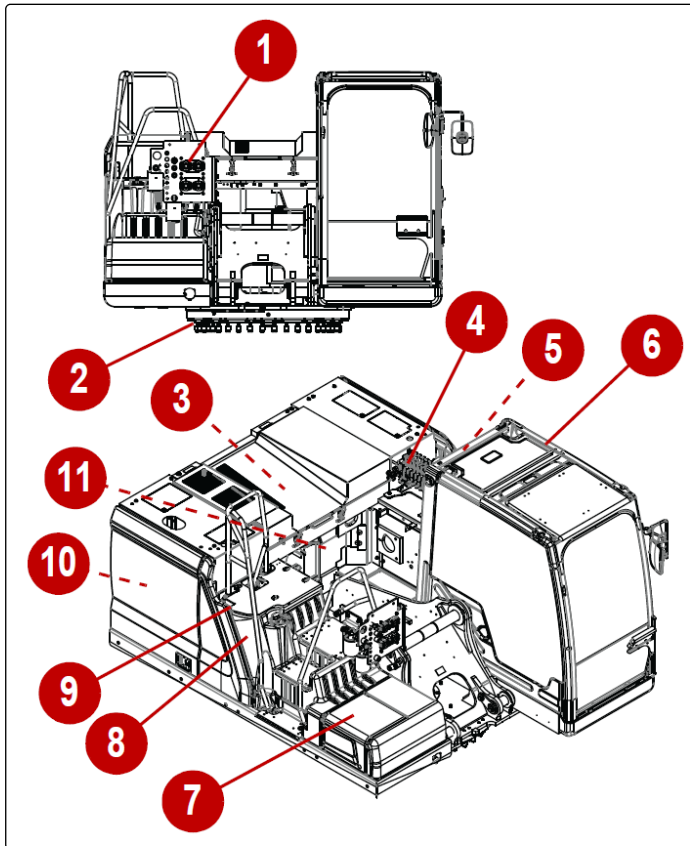

0000263 Base

Pos.	Description
1	Base Manifold
2	Swing Bearing
3	Diesel Engine
4	Auxiliary Proportional Control Valve
5	Battery Compartment
6	Cab
7	Def Tank Compartment
8	Diesel Fuel Tank
9	Hydraulic Tank
10	Hydraulic Pumps Compartment
11	Main Cat Control Valve

The EK125 base is a Caterpillar 323 Next Generation excavator upper, hydraulically driven revolving platform with the drilling rig attached.

It is mounted on the top of the undercarriage through the swing bearing.

The counterweights are mounted to its back and the parallelogram to the front.

The base is where these components are located:

- diesel engine.
- hydraulic pumps.
- controls valves.
- diesel tank.
- hydraulic tank.
- cab.

3.1.4.4. Cab

Figure 7.

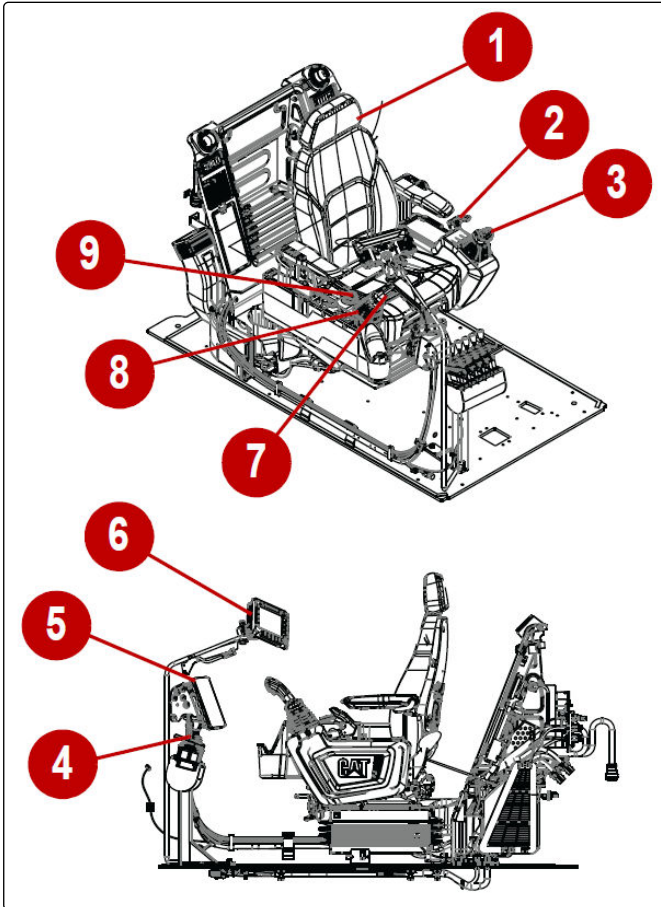

0000264 Cab

Pos.	Description
1	Operator Seat
2	Safety Lever
3	Left Joystick
4	Auxiliary Joysticks
5	CAT Monitor
6	CZM Monitor
7	Right Joystick
8	CAT Monitor Knob
9	On/off Switch

The cab is where the operator sits and operates the drilling rig.

**NOTICE**

The operator seat is designed and manufactured according to ergonomic principles.

**DANGER**

The operator must always wear his seat belt and close the door while the machine is turned on.

The CZM Monitor will give the operator information on the drilling parameters and functions.

The CAT Monitor will provide the operator with the base information.

When the safety lever is pushed down, all the hydraulic functions are deactivated.

The right and left joysticks will control the main functions of drilling.

The auxiliary joysticks are a 5 section lever valve that will control the setup functions.

3.1.4.5. Parallelogram

Figure 8.

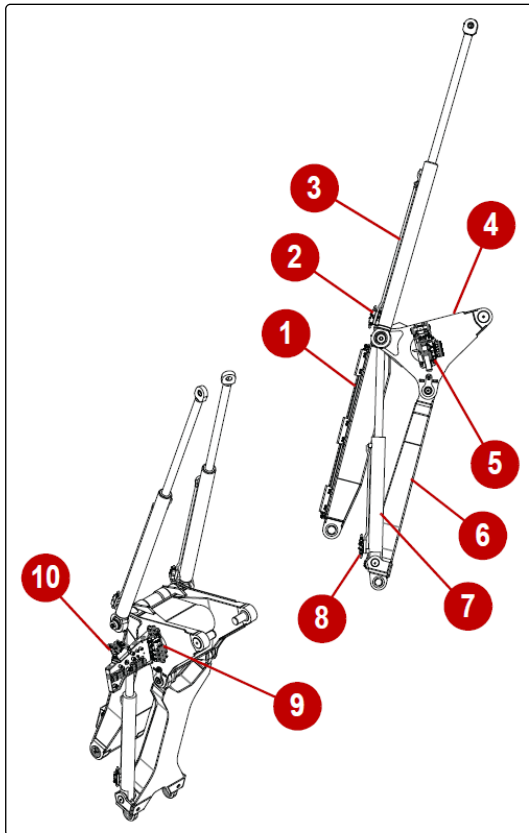

0000267 Parallelogram

Pos.	Description
1	Upper Arm
2	Holding Valves
3	Tilt Cylinders
4	Triangular Element
5	Triangular Element Manifold
6	Lower Arm
7	Boom Cylinders
8	Holding Valves
9	Pilot Manifold
10	3-Spool Valve

The parallelogram connects the mast to the machine base. It consists of the upper and lower arms, triangular element, boom cylinders, and tilt cylinders.

The boom cylinders move the parallelogram and mast forward and back. When this is moved, the mast does not change its angle, so if it is plum it will remain plum.

3.1.4.5.1. Upper Arm

The upper arm connects the triangular element to the chassis.

3.1.4.5.2. Lower Arm

The lower arm connects the triangular element to the chassis.

3.1.4.5.3. Triangular Element

The triangular Element connects the arm to the mast.

3.1.4.5.4. Boom Cylinders

The boom cylinders move the parallelogram.

3.1.4.5.5. Tilting Cylinders

The tilt cylinders are responsible for lifting the mast from the transport position to the operating position and to align it front and back and side to side.

3.1.4.6. Mast

3.1.4.6.1. Main Mast

Figure 9.

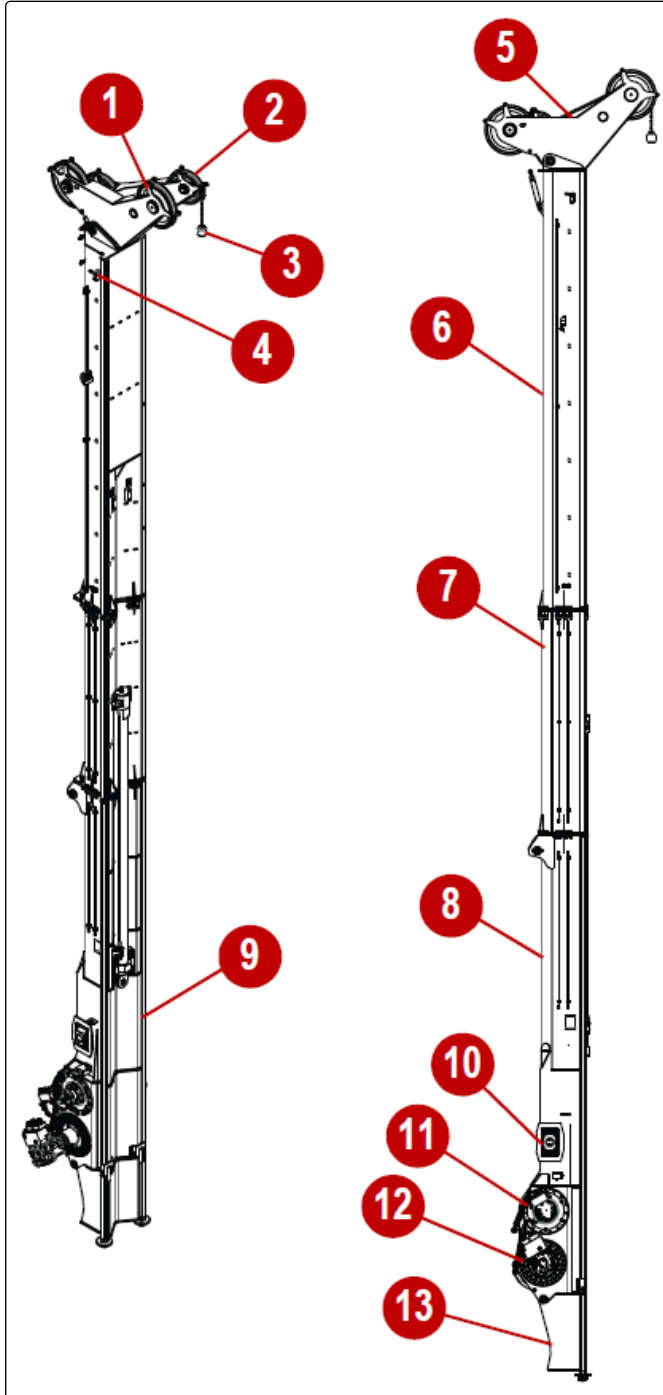

0000234 Mast

Pos.	Description
1	Main Winch Pulley
2	Service Winch Pulleys
3	Auxiliary Winch Limit Switch
4	Main Winch Limit Switch
5	Mast Head
6	Upper Mast
7	Mast Extension
8	Crowd Cylinder
9	Main Mast
10	Mast Yoke
11	Auxiliary Winch
12	Main Winch
13	Foot Mast

The mast is connected to the parallelogram through the mast yoke (10). It needs to resist the torque of the rotary and the crowd force, main winch pull force, and auxiliary winch pull force.

There are several configurations of the mast: the standard mast, the short mast, and other special configurations in between.

The main mast (9) is always present and is where the main winch (12), auxiliary winch (11), and crowd cylinder (8) are mounted.

The mast extension (7) and upper mast (6) are present on the standard mast configuration and are removed for the short mast configuration.

The foot mast (13) can be removed to work with a large diameter tool under the mast.

The mast head (5) is at the very top where the main winch pulley (1) and auxiliary winch pulley are located.

The main winch limit switch (4) and auxiliary winch limit switch (3) are mounted on the upper mast below the mast head.

3.1.4.6.2. Upper Mast

Is bolted to the mast and can be disassembled for transport if necessary.

3.1.4.6.3. Mast Detent

The mast detent is on the side of the mast. They are used to lock the position of the A-frame after changing drilling or between transport positions.

3.1.4.7. Mast Head

Figure 10.

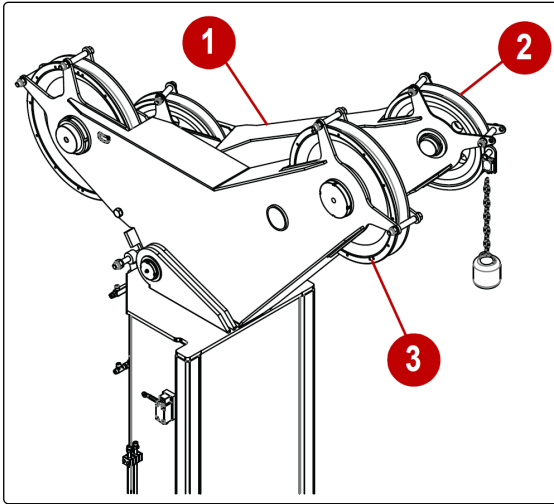

0000268 Mast Head

The mast head (1) is the top of the mast where the main winch pulley (3) and auxiliary winch pulley (2) are located.

3.1.4.8. A-Frame

Figure 11.

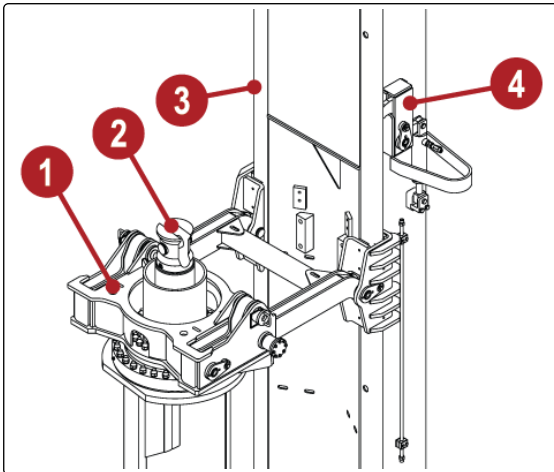

0000269 A-Frame

The A-frame (1) guides the Kelly bar (2) along the mast rail (3).

The A-frame will fold toward the mast to allow the Kelly bar to rest lower for transport.

The mast detent (4) is located on the side of the mast and is used to lock the A-frame guide between transport and drilling positions.

3.1.4.9. Crowd Cylinder

Figure 12.

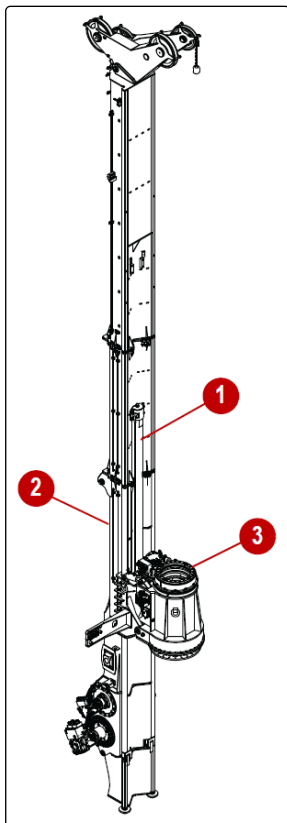

0000265 Crowd Cylinder

Pos.	Description
1	Crowd Cylinder
2	Mast
3	Rotary

The crowd cylinder connects the rotary to the mast. It is responsible for moving the rotary up and down the mast applying crowd force to the drilling tool through the rotary. The crowd force is measured by the pressure applied during this operation and displayed to the operator on the CZM monitor inside the cab.

It has a regenerative hydraulic system for crowd operation, which increases the speed to lower the cylinder.

! IMPORTANT
 The operator should not overcrowd, or lift the machine more than 2.5° of vertical, as it may damage the kelly bar.

CZM's control system can limit the maximum crowd force based on the inclination of the machine and based on the maximum torque, to achieve the best drilling performance.

The operator may also apply auto crowd, which will automatically crowd until a certain depth is achieved.

3.1.4.10. Main Winch

Figure 13.

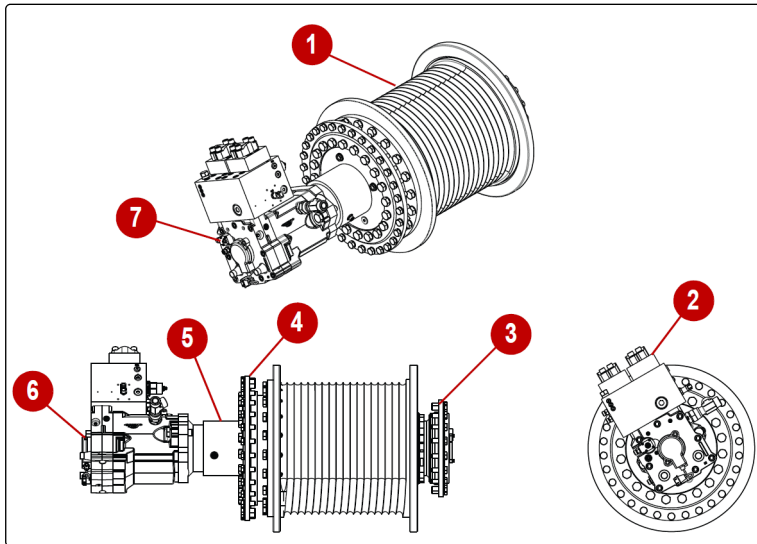

000235 Main Winch

Pos.	Description
1	Main Winch Drum
2	Hydraulic Manifold
3	Winch Bearing
4	Winch Planetary Drive
5	Winch Brake
6	Main Winch Sensor
7	Hydraulic Piston Motor

The main winch is connected to the kelly bar inner element through the kelly bar swivel and is responsible to lower and lift the kelly bar and auger.

The main winch consists of a hydraulic piston motor (7), connected to a winch planetary drive (4) inside the main winch drum (1). The hydraulic manifold (2) is mounted on top of the hydraulic piston motor. The hydraulic piston motor has 2 speeds for increased productivity and the machine control can change the speeds automatically based on the required load. There is also an incorporated main winch sensor (6) to measure the depth and line speed.

The planetary drive has an incorporated mechanical winch brake (5). The main winch drum is supported between sets of winch bearings (3) to provide smooth rotation.

The hydraulic manifold has a dynamic holding valve, which is a down-the-hole function that automatically stops the winch from turning when the kelly bar hits the bottom of the hole, and a free-wheeling function that drops the kelly bar at the same speed as the crowd cylinder during crowd operation.

The main winch drum has special groves for extended cable life.

3.1.4.11. Auxiliary Winch

Figure 14.

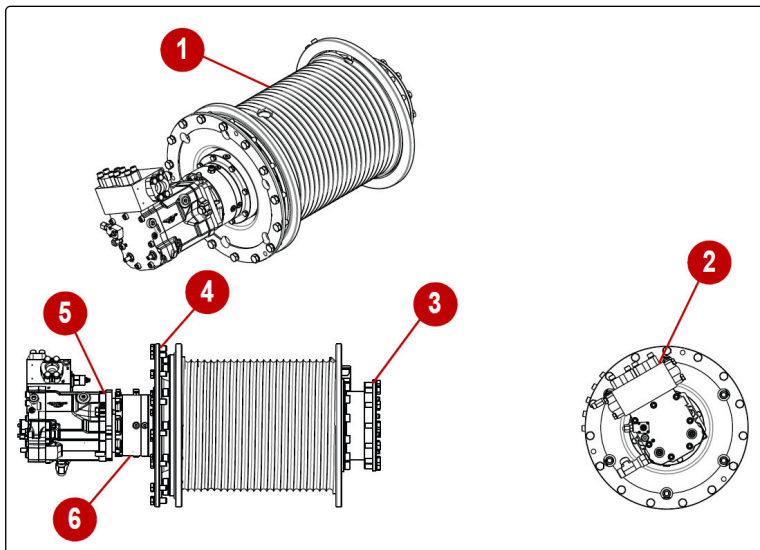

000236 Auxiliary Winch

Pos.	Description
1	Auxiliary Winch Drum
2	Winch Hydraulic Manifold
3	Winch Bearing
4	Winch Planetary Drive
5	Winch Hydraulic Piston Motor
6	Winch Brake

The auxiliary winch can be used to lift loads close to the machine. It consists of a winch hydraulic piston motor (5), connected to the winch planetary drive (4) inside the auxiliary winch drum (1). The auxiliary winch drum is supported between sets of winch bearings (3) to provide smooth rotation.

The winch hydraulic manifold (2) is mounted on top of the hydraulic motor and controls the hydraulic oil flow.

The planetary drive has an incorporated mechanical winch brake (6).

The hydraulic manifold has a dynamic holding valve.

⚠ WARNING

THIS MACHINE IS NOT A CRANE

- The auxiliary winch must be used exclusively for operations relating to the operation of the machine: assembly of some parts of the machine, equipment, and drilling/excavation components.
- Always respect instructions in the [Section: "Limits of Use" \(page 172\)](#).
- Any other use of the auxiliary winch is strictly FORBIDDEN and is considered improper use of the work equipment.

Failure to follow this warning could result in death or serious injury.

3.1.4.12. Rotary

Figure 15.

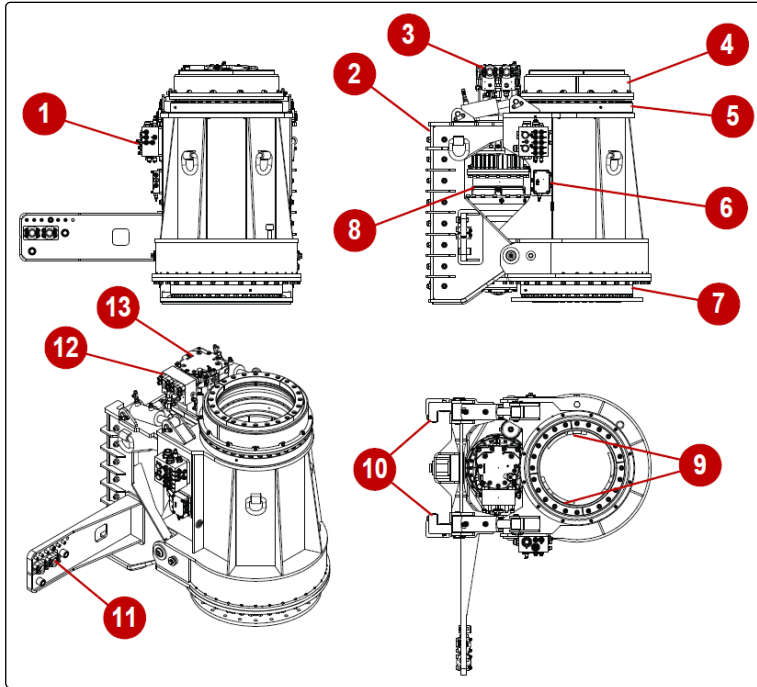

0000237 Rotary Components

Pos.	Description
1	Rotary Drain Manifold
2	Rotary Sled
3	Rotary Speed Sensor
4	Kelly Bar Shock Absorber
5	Rotary Upper Bearing
6	Sequence Valve Manifold
7	Rotary Lower Bearing
8	Rotary Planetary Drive
9	Rotary Keys
10	Rotary Wear Pads
11	Rotary Manifold
12	Rotary Motor Manifold
13	Rotary Hydraulic Piston Motor

The rotary is connected to the mast through the crowd cylinder. It transfers torque and crowd force to the kelly bar that runs through it.

It consists of a rotary hydraulic piston motor (12), that is connected to a 2-speed rotary planetary drive (8) and then to a pinion and main crown gear that are inside the rotary case.

The rotary planetary drive has a clutch that changes the gear ratio, making it 2-speed. The first speed is for drilling and the second for the spin-off.

The rotary hydraulic piston motor has a variable displacement so that the operator can change the drilling speeds.

The rotary hydraulic piston motor has an incorporated rotary speed sensor (3) to measure the output drilling rpm displayed to the operator in the cab.

The torque is also measured by a pressure transducer in the rotary line.

The rotary motor manifold (11) has an anti-shock and anti-cavitation system. This increases the life of the rotary hydraulic piston motor and allows the operator to abruptly change the reverse of the auger during drilling and spin-off and to shake off the tool for faster auger cleaning.

The machine will auto-shift the gears depending on the required load.

The kelly shock absorber (4) protects the rotary from kelly bar impact.

The rotary keys (9) lock to the kelly bar.

**IMPORTANT**

Grease constantly and replace upon wear to avoid damage.

The rotary wear pads (10) are located inside the rotary sled (2) and run on the mast rails.

**IMPORTANT**

Grease constantly and replace upon wear to avoid damage.

3.1.4.13. Kelly Bar

Figure 16.

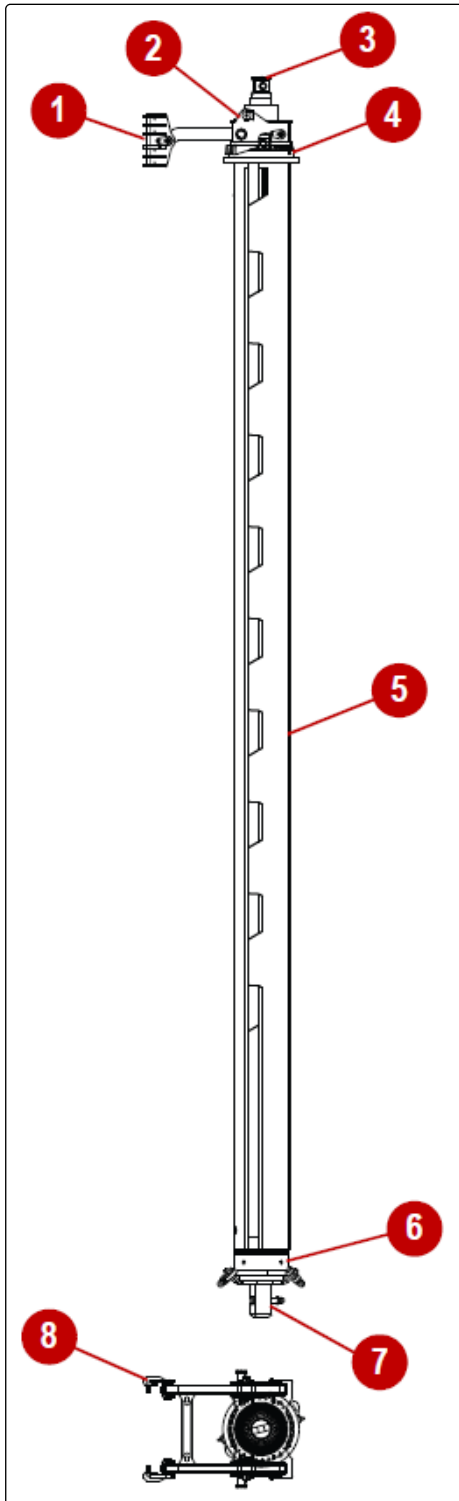

0000238 Kelly Bar

Pos.	Description
1	A-Frame Feet
2	A-Frame
3	Kelly Bar Swivel
4	A-Frame Bearing
5	Kelly Bar
6	Bell Housing
7	Kelly Bar Stub
8	A-Frame Wear Pads

The kelly bar (5) is the main drilling tool that is connected to the auger itself. It consists of telescopic pipes with vertical rails that lock for transmitting torque and crowd force in between the kelly elements.

There are two kelly bar types:

- Friction kelly bars, the crowd is only transmitted to the inside elements by the friction in between the vertical rails;
- Interlocking kelly bars, there are also horizontal keys that lock the elements to each other, transferring the maximum torque for an effective crowd to the auger.

The number of elements and length of the kelly bar will determine the drilling depth. Generally, a kelly bar will consist of 3 to 5 elements.

The length of the kelly bar needs to match the length of the mast. The clearance under the tool will be a factor of the length of the mast and the length of the kelly bar.

The kelly bar is lowered and lifted from the hole by the main winch line. The winch line is connected to the kelly bar swivel (3). This prevents the kelly bar from twisting the main winch cable.

The rotary transmits the torque and crowd for the drilling with the kelly bar running through the inside of it.

The kelly bar stub (7), is at the bottom of the kelly bar that connects to the tool. It is a square with 1 or 2 holes and can have different tool configurations.

The A-frame (2) bolts to the top of the kelly bar outer element mast rails to guide the top of the kelly bar.

The A-frame wear pads (8) allow the A-frame to slide along the mast.

IMPORTANT
Grease constantly and replace upon wear to avoid damage.

NOTICE
For better kelly bar life, don't overcrowd lifting the base machine off the ground.

IMPORTANT
Frequently inspect the kelly bar for cracks and repair them right away. Inspect the worn keys and repair them as needed.

3.1.5. Description Of Hydraulic Implements

Figure 17.

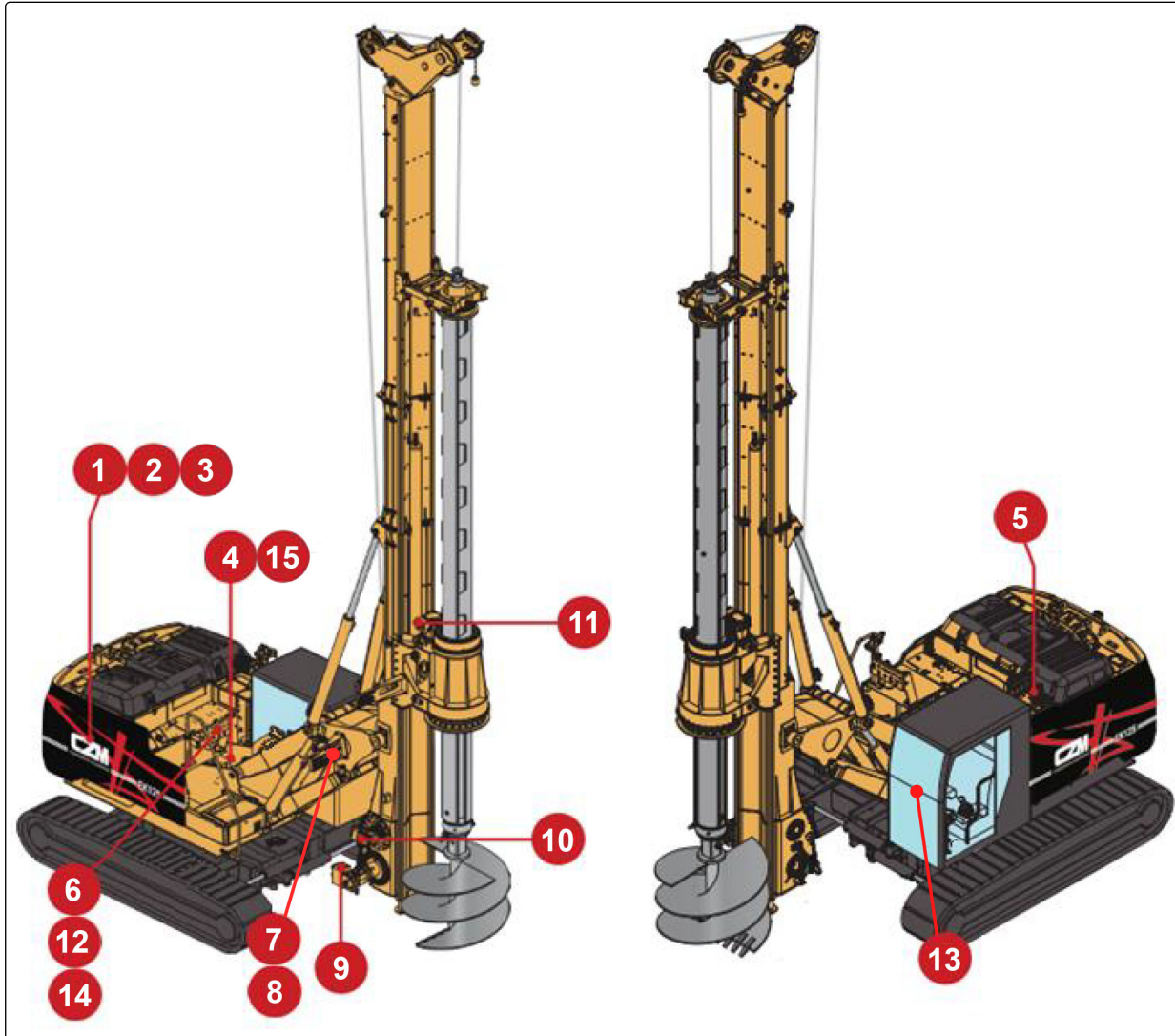

000114 Hydraulic Components

Pos.	Description	Pg.
1	Main CAT Pumps	56
2	Auxiliary Piston Pump	56
3	Cooling Pump	56
4	Main CAT Control Valve	56
5	Auxiliary Proportional Control Valve	57
6	Regenerative System Manifold	57
7	Solenoid Manifold	57

Pos.	Description	Pg.
8	3 Spool Valve	57
9	Main Winch Manifold	57
10	Auxiliary Winch Manifold	57
11	Rotary Manifold	57
12	Drain Return Filters	58
13	Pump Gauges	58
14	Hydraulic Tank	58
15	Heat Exchanger	58

3.1.5.1. Main CAT Pumps

The main CAT pumps provide hydraulic oil flow to power the main functions of the drill rig.

These functions are:

- rotary.
- main winch.
- crawlers.

The pump flow of both pumps is combined to provide maximum performance, utilizing the full horsepower of the engine for the rotary and main winch functions.

3.1.5.2. Auxiliary Piston Pump

The auxiliary piston pump supplies hydraulic oil flow to the auxiliary proportional control valve providing power to the auxiliary functions.

These auxiliary functions are:

- crowd.
- auxiliary winch.
- swing.
- boom cylinder.
- tilting cylinders.
- undercarriage retract/extend.
- mast set up.

3.1.5.3. Cooling Pump

The cooling pump flushes clean and cool hydraulic oil through the rotary planetary gear transmission, rotary piston motor, and main winch piston motor.

The hydraulic oil is routed through the drain line filters, heat exchanger, and main return filter.



NOTICE
The cooling pump increases the life of the components.

3.1.5.4. Main CAT Control Valve

The main CAT control valve is supplied hydraulic oil flow by the main CAT pumps and directs it to:

- rotary.

- main winch.
- left crawler.
- right crawler.

3.1.5.5. Auxiliary Proportional Control Valve

The auxiliary proportional control valve supplied hydraulic oil flow by the auxiliary piston pump and directs it to:

- crowd.
- auxiliary winch.
- swing, boom cylinder.
- tilting cylinders.
- undercarriage retract/extend.
- mast set up.

3.1.5.6. Regenerative System Manifold

The regenerative system manifold is used to increase the speed of cylinder extension of the crowd cylinder, thus increasing the productivity of the machine.

3.1.5.7. Solenoid Manifold

The solenoid manifold is located on the triangular element and pilots functions such as:

- main winch second speed.
- main winch brake.
- main winch down the hole exclusion.
- rotary proportional speed changes.
- power shift on/off.

3.1.5.8. 3-Spool Valve

The 3-spool valve is located on the triangular element and controls:

- mast head cylinder.
- rotary tilt cylinders.
- mast detent cylinder.

3.1.5.9. Main Winch Manifold

The main winch manifold is mounted to the main winch motor.

It has:

- a counterbalance valve, that acts as a dynamic brake for the main winch.
- a down-the-hole function, that stops the winch from turning when the tool hits the bottom of the hole avoiding cable bird nesting.
- a free spool function that allows the winch to drop at the same speed as the rotary travel during crowd, avoiding over tensioning the cable.

3.1.5.10. Auxiliary Winch Manifold

The auxiliary winch manifold is mounted to the auxiliary winch piston motor.

It has a counterbalance valve, that acts as a dynamic brake for the auxiliary winch.

3.1.5.11. Rotary Manifold

The rotary manifold is mounted to the rotary piston motor.

It provides an anti-shock system and anti-cavitation function that is important to prevent damage to the motors while drilling and while abruptly reversing the rotary direction to clean the augers.

3.1.5.12. Drain Return Filters

Two drain return filters are mounted to the base manifold.

3.1.5.13. Pump Gauges

Three pressure gauges are mounted by the cabin to monitor the hydraulic pressure of the main CAT pump 1, main CAT pump 2, and auxiliary piston pump.

3.1.5.14. Hydraulic Tank

The hydraulic tank is pressurized to provide better pump oil suction.
The main return filter is internally mounted.

3.1.5.15. Heat Exchanger

The heat exchanger uses 3 electric fans to cool 100% of the hydraulic oil before returning to the hydraulic tank.

3.1.6. Description of Electrical Implements

Figure 18.

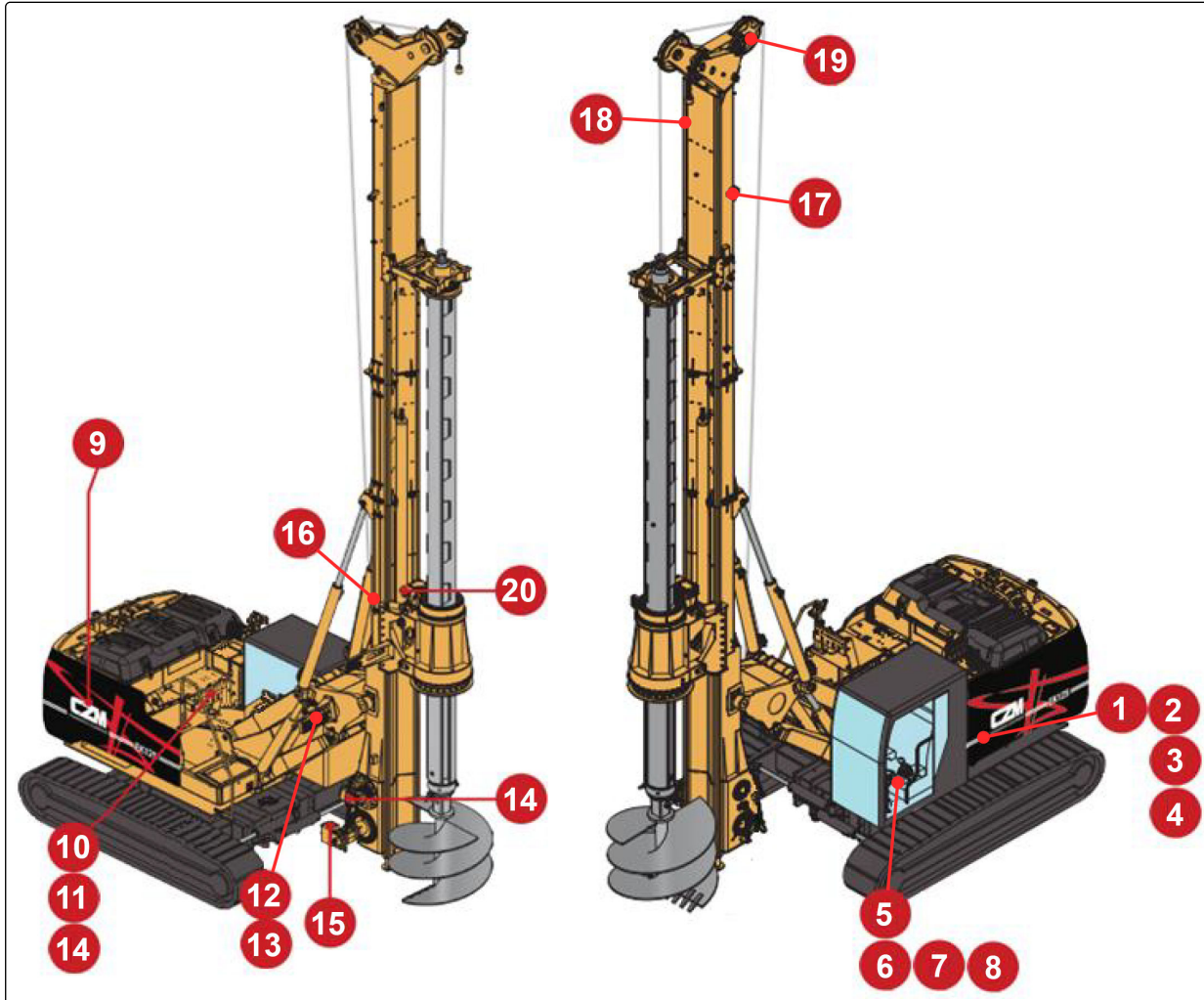

000115 Electrical Implements

Pos.	Description	Pg.
1	Power Supply Box	60
2	Base Controller	60
3	Base Output Expander	60
4	Cooling Controller	60
5	Signal Conditioning Module	60
6	Cab Controller	60
7	Auxiliary Joysticks	61
8	CZM Monitor	61

Pos.	Description	Pg.
9	Pump P1 Pressure Sensor	61
10	Return to Center Sensor	61
11	Return Filter Sensor	61
12	Mast Controller	61
13	Mast Output Expansion Module	61
14	Pressure Sensor	62
15	Main Winch Depth Sensors	62
16	Mast Slope Sensor	62
17	Mast Lights	62
18	Main Winch Limit Switch	62
19	Auxiliary Winch Limit Switch	62
20	RPM Sensor	63

3.1.6.1. Power Supply Box

The power supply box distributes incoming power through relays and switches to the complete CZM electronic system.

3.1.6.2. Base Controller

The base controller is a CAN bus module located in the battery compartment. It controls the solenoids for the auxiliary proportional control valve and pressure sensors.

3.1.6.3. Base Output Expansion Module

The base output expansion module is a CAN bus module that expands the number of outputs for the base controller.

3.1.6.4. Cooling Controller

The cooling controller is a CAN bus module located in the heat exchanger compartment. It controls the output for the electric fans for the hydraulic oil heat exchanger, engine and engine coolant. If equipped, it also controls the inputs and outputs of the self-erecting counterweight.

3.1.6.5. Signal Conditioning Module

The signal conditioning module is located inside the cabin, behind the seat. It converts the signal of the Caterpillar joysticks from 5V to 7V, so it can be read by the CZM electronic system.

3.1.6.6. Cabin Controller

The cabin controller is a CAN bus module, located inside the cabin, behind the seat. It controls the inputs and outputs from the CAT joysticks and the auxiliary Joysticks. It also connects to the CZM monitor.

3.1.6.7. Auxiliary Joysticks

The auxiliary joysticks are located inside the cabin, in front of the operator's seat.

They control:

- auxiliary winch.
- boom.
- left tilting cylinder.
- right tilting cylinder.

3.1.6.8. CZM Monitor

The CZM monitor controls the drilling part of the machine.

It is connected to the base controller module by a CAN bus line.

It gives the operator information that helps him operate the machine such as:

- drilling torque.
- rotary speed.
- main winch pulling force.

It also displays any fault if present and it gives the operator the maintenance schedule.

3.1.6.9. Pump P1 Pressure Sensor

The pump P1 pressure sensor sends pressure reads to the pressure gauges for operator observation during the drilling operation.

3.1.6.10. Return to Center Sensor

The return to center sensor is an encoder mounted on the top of the swivel.

It measures the angle of the upper body, compared to the undercarriage and it is used to automatically return the machine back to the center of the hole.

3.1.6.11. Return Filter Sensor

The return filter sensor will give the indication to the operator if the return filter is clogged and consequently by-passing to the tank.



IMPORTANT

Replace the filter cartridge when clogged.

3.1.6.12. Mast Controller

The mast controller is a CAN bus module located in the triangular element manifold.

It controls:

- inputs and outputs for the solenoid manifold.
- 3-spool valve.
- rotary rpm sensor.
- main winch depth sensor.
- mast lights.
- main winch limit switch.
- auxiliary winch limit switch.

3.1.6.13. Mast Output Expansion Module

The mast output expansion module is a CAN bus module that expands the number of outputs for the mast controller.

3.1.6.14. Pressure Sensors

The pressure sensors are located in the base manifold.

It measures:

- hydraulic pressure for the rotary in both directions.
- main winch in the up direction.
- crowd cylinder.

This data is used to :

- display the rotary torque.
- display the main winch pull-up force.
- display the crowd force.
- automatically change the rotary gears and the main winch gear.

3.1.6.15. Main Winch Depth Sensor

The main winch depth sensor is a speed sensor mounted to the main winch hydraulic motor.

It measures the rotation of the motor to calculate the depth as well as the main winch speed.

3.1.6.16. Mast Slope Sensor

The mast slope sensor is mounted to the mast.

It measures the inclination of the mast, within 10 degrees from the plum.

This information is displayed to the operator in the CZM monitor and it is used to the auto mast level.

3.1.6.17. Mast Lights

The mast lights are auxiliary lights located on the mast.

3.1.6.18. Main Winch Limit Switch

The main winch limit switch is an anti-2 block that stops the main winch from going up and hitting the pulley.

It is normally open, so if it is damaged the winch will not go up.

This operation can be bypassed by the operator in the cab.



WARNING

Bypassing the limit switches is very dangerous and can cause accidents with injuries or even death.

The bypass of the limit switches must be used only in these cases:

- Emergency, to bring the machine back to safety conditions.
- Assembly.
- Disassembly.
- Maintenance.

Maximum caution is required during operations.

Failure to follow this warning could result in death or serious injury.

Failure to follow this warning could result in damage to equipment or cause it to operate improperly.

3.1.6.19. Auxiliary Winch Limit Switch

The auxiliary winch limit switch is an anti-2 block that stops the auxiliary winch from going up and hitting the pulley.

It is normally open, so if it is damaged the winch will not go up.

This operation can be bypassed by the operator in the cab.

**WARNING**

Bypassing the limit switches is very dangerous and can cause accidents with injuries or even death.

The bypass of the limit switches must be used only in these cases:

- Emergency, to bring the machine back to safety conditions.
- Assembly.
- Disassembly.
- Maintenance.

Maximum caution is required during operations.

Failure to follow this warning could result in death or serious injury.

Failure to follow this warning could result in damage to equipment or cause it to operate improperly.

3.1.6.20. RPM Sensor

The rpm sensor is a speed sensor mounted to the rotary hydraulic motor.

It measures the rotation of the motor and is used to calculate the output rpm of the rotary.

This information is displayed to the operator in the CZM monitor.

3.1.7. Description of Symbols

Figure 19.

	UNDERCARRIAGE CYLINDERS		POWER SHIFT		SIDE CAMERA
	CRAWLERS		MAST HEAD ROTATE		FAULTS
	PARALLELOGRAM (BOOM)		MAST SHOE	N/A	FUNCTION NOT IMPLEMENTED
	LEFT TILT CYLINDER		MAST LIGHTS		MAST LOCK
	RIGHT TILT CYLINDER		MAST DETENT		DRILL DEPTH PROGRESS
	RETURN TO CENTER		MAIN WINCH MOVEMENT		MAIN WINCH AUTO SHIFT
	SWING		AUXILIARY WINCH MOVEMENT		MAIN WINCH LOW
	PULLDOWN CYLINDER		LIMIT SWITCH EXCLUSION MAIN WINCH		HIGH SPEED CROWD
	SET CURRENT DEPTH TO ZERO		LIMIT SWITCH EXCLUSION, AUXILIARY WINCH		
	ROTARY CYLINDERS		END HOLE EXCLUSION, MAIN WINCH		
	HORN		MAST AUTO LEVEL		
	ROTARY ROTATION		AUTO DRILL		
	ROTARY SPEED		AUTO CROWD		

FOUNDATION EQUIPMENT

0000225 Symbols

4. SAFETY

4.1. GENERAL CONSIDERATIONS

This section provides information on basic safety precautions, as well as preventive measures that should be followed when operating the drilling rig.

Overall safety is the responsibility of the operator and job site personnel.



NOTICE

To reference British Standards, consult the latest publication for drilling and foundation equipment from The British Standard Institution as BSI Standards Publication.

It is impossible to compile a comprehensive list of safety precautions that covers every possible situation that may be encountered. However, there are basic operating guidelines and principles that must be followed when operating or working on the drilling rig:

- Only authorized and qualified personnel specifically trained on this drilling rig are permitted to operate it;
- Read and understand this manual and any accompanying manuals before operating this drilling rig to make sure all operations can be performed safely;
- Read and understand the base machine operation manual before operating. If there is a difference between the cross-over and the base machine manual, follow the base machine manual information.

It is important to pay constant attention to the effects that could arise from any action performed on the machine itself.

An accident can be avoided by recognizing potentially dangerous situations in advance.

To avoid dangerous situations, proceed as indicated:

1. Read and understand the safety standards before reading the following paragraphs;
2. Always perform the machine function test before using the machine;
3. Check the work area before starting the machine;
4. Use the machine only for the functions it was designed for.



DANGER

Failure to follow the instructions and safety rules included in this manual can result in death or serious personal injury.



DANGER

Read, understand and follow:

- Safety standards;
- CZM operation and maintenance manual;
- Base machine operation and maintenance manual;
- Safety labels on the machine.



DANGER

The use of the machine is reserved for qualified and suitably trained personnel.



DANGER

It is strictly forbidden to modify or alter this machine and its components or any function without first consulting CZM.

4.2. PERSONNEL

4.2.1. Personnel with Duty of Consultation

This manual is aimed at all those who, regardless of the professional position held, come into direct contact with the machine or, in any case, are working in the area surrounding the machine itself.

Figure 20.



0000400 Obligation To Read The Manual

4.2.1.1. Machine Operator

A qualified technician, appropriately trained (in compliance with the legislation in force in the country of use) qualified to use the machine.

He is the person responsible for the correct use and operation of the machine and for coordinating all the activities carried out in collaboration with the assistants and maintenance personnel.

In this manual, it is represented by the following symbol .



WARNING

Do not work with the machine if tired or unwell. Pay particular attention at the end of the work shift.

4.2.1.1.1. Operator's Duties

The operator performs his duties in full compliance with the instructions in this manual.

- The operator must always make sure that assistants and maintenance personnel work in safe conditions, checking their position and working methods.
- The operator must always follow the signals of the assistants and maintenance personnel and must respect any stop signal from anyone working on the site.

4.2.1.1.2. Operator's Tasks

The operator's tasks are:

- The traveling of the machine.
- The stabilization of the machine.
- The positioning of the mast.
- The use of the work equipment.
- The cleaning of the machine (if necessary with the help of an assistant).
- The inspection of the machine to identify:
 - a. Worn or damaged parts: in this case, the operator must immediately request the intervention of the maintenance personnel.
 - b. Parts that are not solidly fixed: in this case, the operator can repair them according to his possibilities and responsibilities.
- Periodic check of the contents of the first aid kit (to be restored if necessary).

4.2.1.1.3. Operator's Requirements

The operator using the machine must meet the following requirements:

- be in adult age.
- be physically and mentally fit for his job.
- be properly trained and have recognized skills.
- know the signs in use on the construction site.
- read this manual carefully before using the machine.
- perfect knowledge of the performance and limits of use of the machine.
- perfect knowledge of the tasks he must perform.
- perfect knowledge of the machine operation, controls, and components.
- perfect knowledge of all the safety devices installed in the machine.
- perfect knowledge of the warnings and safety signs.
- perfect knowledge of the use of PPE.
- perfect knowledge of the residual risks of the machine.
- perfect knowledge of the forbidden uses of the machine.
- perfect knowledge of the fire extinguisher position.

4.2.1.2. Operator Assistant

A selected technician, suitably trained to carry out assistance tasks of the machine's activities.

The assistance staff can be composed of one or more job site operators, who use other operating machines (cranes, shovels, etc.), provide service to the machine and collaborate with the operator.

The assistant must meet the following requirements:

- be physically and mentally fit for his job.
- be properly trained and have recognized skills.
- know the signs in use on the construction site.
- read this manual carefully before using the machine.

In this manual, it is represented by the following symbol .

4.2.1.3. CZM Technician

A qualified technician, made available by CZM, to carry out:

- technical assistance.
- ordinary and extraordinary maintenance.
- operations not listed in this manual that require specific knowledge of the machine.

4.2.1.4. Specialized Technician

Person in charge and/or authorized by the manufacturer and/or his dealer to carry out interventions on the machine or on the equipment installed, in which precise technical competence and particular skills are required.

The fields of specialization can differ according to the sectors of service (mechanical, hydraulic, electrical, etc.).

The technician, in addition to having specific skills in service, must be able to read and interpret the relevant diagrams (electrical, electronic, hydraulic, etc.) to recognize the different characteristics and functions of the devices immediately and correctly.

The specialized technician, who carries out service on the machine, must:

- be properly trained and have recognized skills in the specific sector (electrical, hydraulic, etc.).
- read this manual carefully before using the machine.
- learn about the specific risks of the machine.

4.2.2. Operative Personnel

Only one operator is necessary to use this drilling rig.

However, it is recommended the presence of one or more assistants.



DANGER

Personnel must always respect the Danger Zones. See [Danger Zones \(page 164\)](#) for more information.

4.2.3. Signal Person and Hand Signals



WARNING

Hand signals must be mutually agreed upon by the operator and the signal person before operations begin. Proper communication is essential to job site safety.

Failure to follow this warning could result in death or serious injury.

Responsibilities of the signal person include:

- Using hand signals that are easily identified and understood by the operator to provide effective communication.
- Standing in a safe location while observing potential hazards within the danger zone. See [Danger Zones \(page 164\)](#) for more information.
- Different countries may have different hand signals: follow the local hand signal standards.

4.2.4. Personal Protective Equipment (PPE)

All personnel must be equipped with the Personal Protective Equipment (PPE) prescribed by the law in force.

The choice of equipment depends on the type of operation to be performed.

Figure 21.

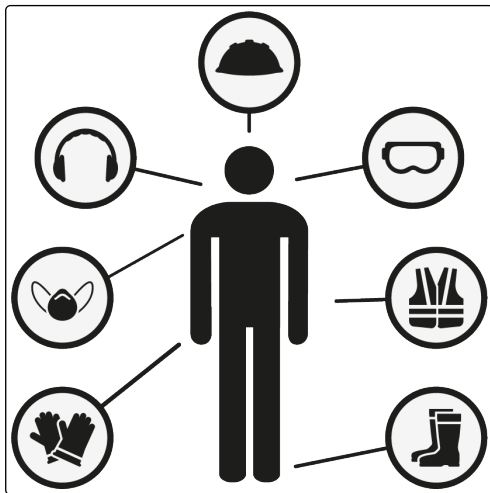

0000404 Personal Protective Equipment (PPE)



WARNING

- Do not wear rings, wristwatches, jewelry, loose or dangling clothing that can get caught in moving parts;
- The hard hat must be clean and in good condition. Each operator must personally carry out the adjustment respecting his characteristics;
- Gloves must be snug, with no protruding parts that could get caught in the machine mechanisms. They must protect against abrasions caused by metal cables and irregular, angular and sharp edges;
- Consult the employer about the safety regulations in force and the accident prevention devices;
- To work in full compliance with safety regulations, it is necessary to wear protective clothing in accordance with the law, checking that these are always in perfect condition;
- Each visitor authorized to enter the work area must wear all the protections required by law for work on site.

4.3. SAFETY MESSAGES*

SMCS Code: 7000; 7405

There are several specific safety messages on this machine.

The exact location of the hazards and the description of the hazards are reviewed in this section.

Other safety messages could be added if the machine is equipped with optional, which this manual does not currently provide.

Please become familiar with all safety messages.



IMPORTANT

- Make sure that all the safety messages are legible.
- Clean the safety messages or replace the safety messages if you cannot read the words.
- Replace the illustrations if the illustrations are not visible.
- If one or more safety messages are damaged and/or illegible, ask CZM to replace them.
- If a safety message is on a component to be replaced, make sure that the new safety message is applied to the new component.
- When you clean the safety messages, use a cloth, water, and soap.
- Do not use solvent, gasoline, or other harsh chemicals to clean the safety messages. Solvents, gasoline, or harsh chemicals could loosen the adhesive that secures the safety message. Loose adhesive will allow the safety message to fall.

4.3.1. Seat Belt*

This safety message is located in the cab on the right side window.

Figure 22.

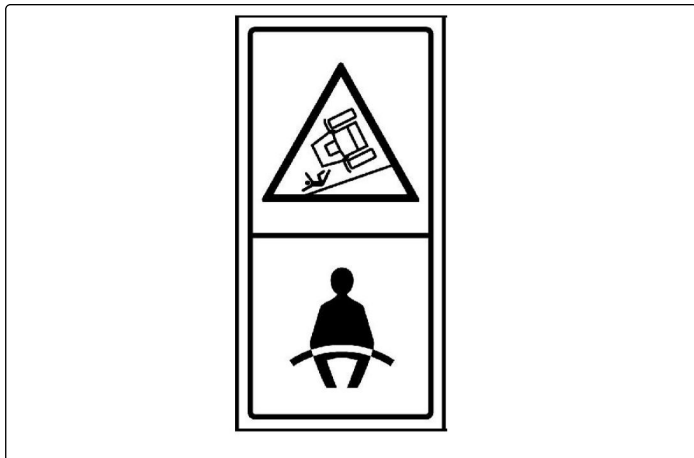

g06188642 Seat Belt



WARNING

A seat belt should be worn at all times during machine operation to prevent serious injury or death in the event of an accident or machine overturn.

Failure to follow this warning could result in death or serious injury.

4.3.2. Standard Safety Messages

Figure 23.

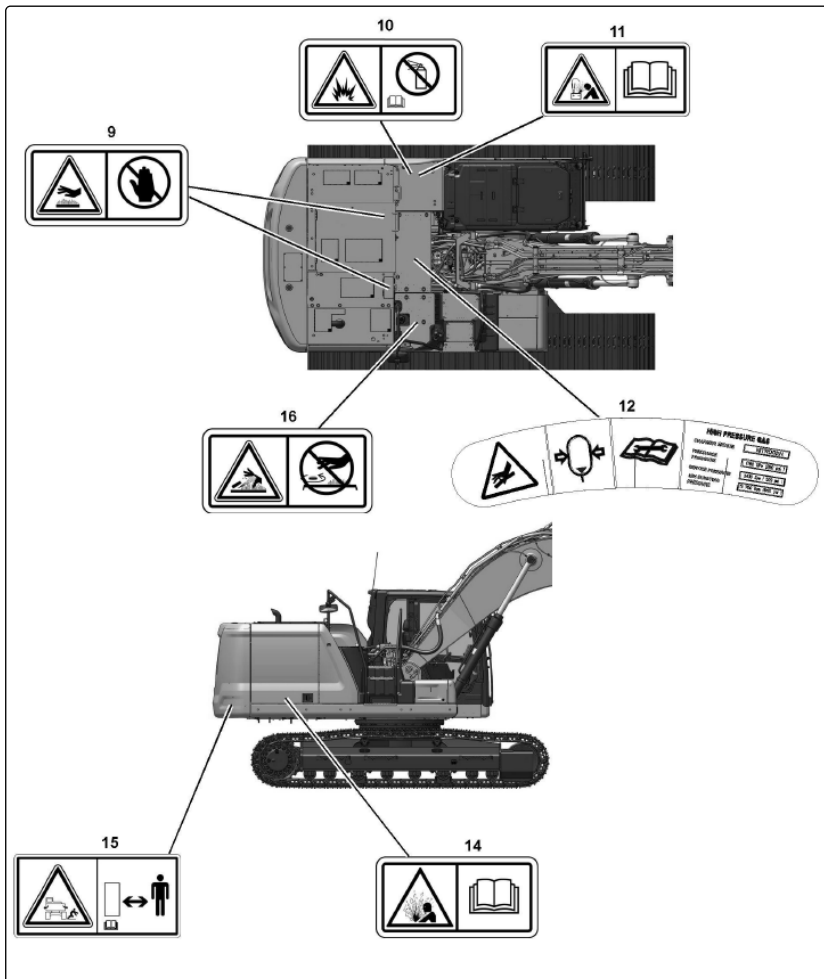

g06180922 Standard Safety Messages Position 1

Figure 24.

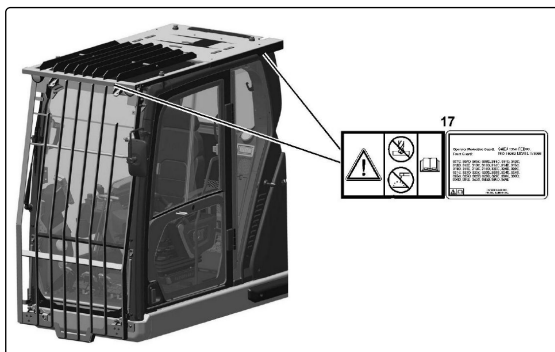

g06184325 Standard Safety Messages Position 2

4.3.2.1. Hot Surface (9)*

This message is on the outside of the engine hood and on the inside of the engine hood.

Figure 25.



g01372256 Hot Surface

**WARNING**

The engine hood and engine hood parts can be hot while the engine is running or immediately after the engine shutdown.

**WARNING**

- Hot parts or hot components can cause burns or personal injury.
- Do not allow these parts to contact your skin when the engine is running or immediately after engine shutdown.
- Use protective clothing or protective equipment to protect your skin.

4.3.2.2. Aerosol Starting Aid (10)*

This safety message is located near the precleaner.

The following information is not applicable to machines that are equipped with an ether starting aid.

Figure 26.



g01372254 Explosion-Ether

**WARNING**

Explosion hazard! Do not use ether!
 This machine is equipped with an air inlet heater.
 Using ether can create explosions or fires that can cause personal injury or death.
 Read and follow the engine starting procedure in this manual.

4.3.2.3. Jump-Start Cables (11)*

This safety message is positioned on the circuit breaker panel.

Figure 27.

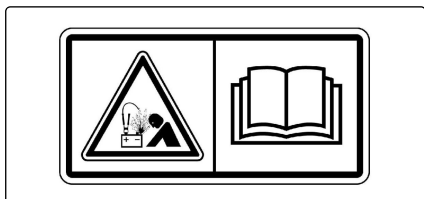

g01370909 Jump-Start Cables



WARNING

Explosion Hazard!
 Improper jumper cable connections can cause an explosion resulting in serious injury or death.
 Batteries may be located in separate compartments.
 Refer to the Operation and Maintenance Manual for the correct jump starting procedure.

4.3.2.4. High-Pressure Gas (12)*

This safety message is positioned on the accumulator.

Figure 28.

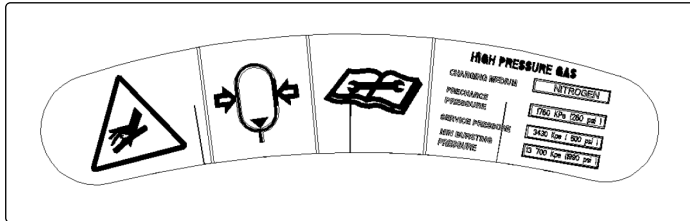

g06188756 High-Pressure Gas



WARNING

Pressurized System!

- Hydraulic accumulators contain gas and oil under high pressure.
- DO NOT disconnect lines or disassemble any component of a pressurized accumulator.
- All gas pre-charge must be removed from the accumulator as instructed by the Operator and Maintenance Manual before servicing or disposing of the accumulator or any accumulator component.
- Only use dry nitrogen gas to recharge accumulators. Contact CZM After Sales Department for special equipment and detailed information for accumulator service and charging.

Failure to follow the instructions and warnings could result in personal injury or death.

4.3.2.5. Vapor Explosion (14)*

If equipped, this safety message is on the storage compartment for the fuel transfer pump.

Figure 29.

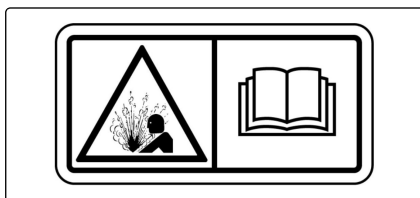

g01407639 Vapor Explosion



WARNING

Explosion hazard!

- Fuel vapors can accumulate in the refueling pump compartment and can be ignited by improper operation of the refueling pump.
- Read and follow the operating instructions for the refueling pump in the Operation and Maintenance Manual.

Failure to follow the operating instructions for the refueling pump could result in personal injury or death.

4.3.2.6. Crushing Hazard (15)*

This safety message is on the rear of each side of the machine.

Figure 30.

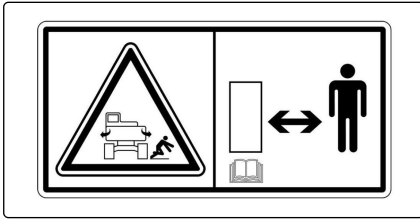

g06219420 Crushing Hazard



WARNING

Base swings, stay back. A crushing hazard could cause serious injury or death.

4.3.2.7. Relieve Hydraulic Tank Pressure (16)*

This safety message is on top of the hydraulic tank.

Figure 31.



g01371640 Relieve Hydraulic Tank Pressure



WARNING

Hot Fluid Under Pressure! Do NOT remove the pressure cap when hot. Hot oil could cause serious injury or death.

4.3.2.8. Falling Object Guard Structure (17)*

If equipped, this safety message is on top of the front falling object guard structure.

This safety message is also on the left side of the falling object guard structure on the top of the cab.

Figure 32.

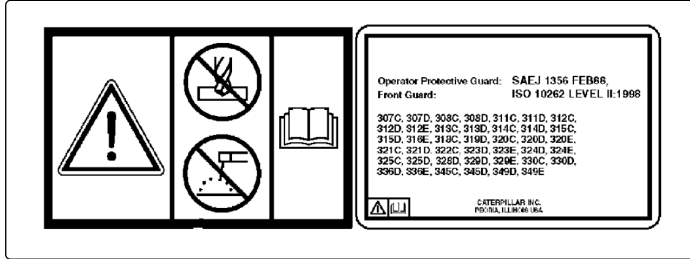

g02428757 Falling Object Guard Structure

WARNING

- Structural damage, an overturn, modification, alteration, or improper repair can impair this structure's protection capability thereby voiding this certification.
- Do not weld on or drill holes in the structure.
- Consult CZM to determine this structure's limitations without voiding its certification.

4.3.3. Additional Safety Messages

Figure 33.

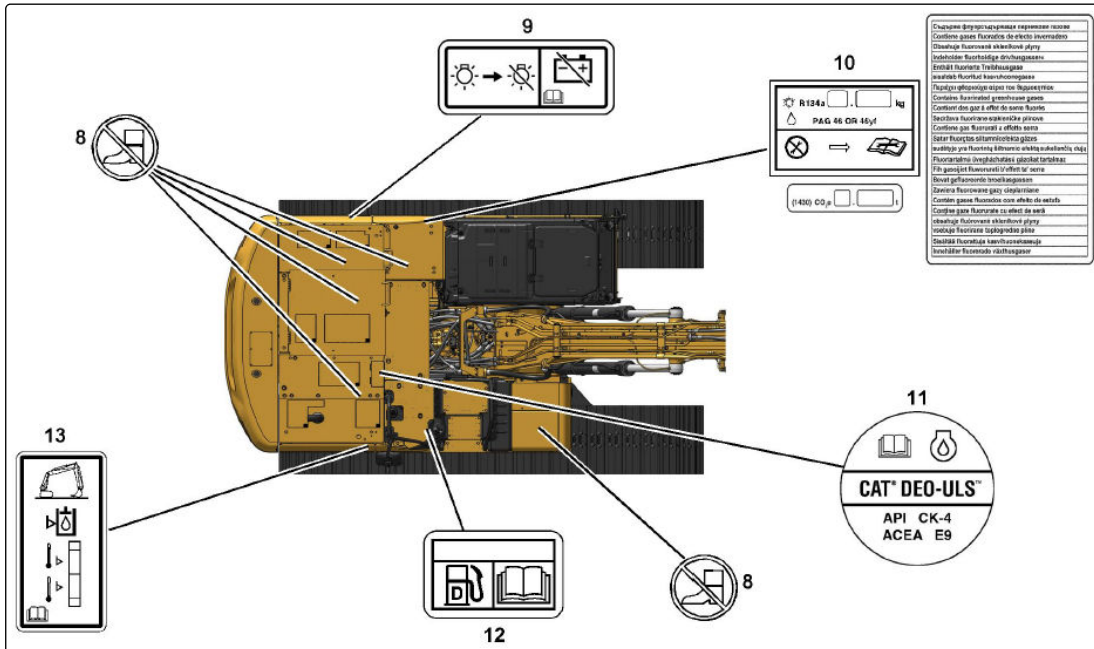

g06491287 Additional Safety Messages Position

4.3.3.1. No Step (8)*

This message is on various places on the upper structure and covers. It is also on the engine valve cover.

Figure 34.

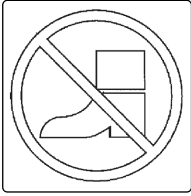

g00911158 No Step

Do not step in this area.

4.3.3.2. DEF Purge Indicator Lamp (9)*

This message is located behind the cab near the disconnect switch and pertains to the Diesel Exhaust Fluid (DEF) system.

For machines equipped with a circuit that stays activated for DEF purge with the disconnect switch off:

Figure 35.

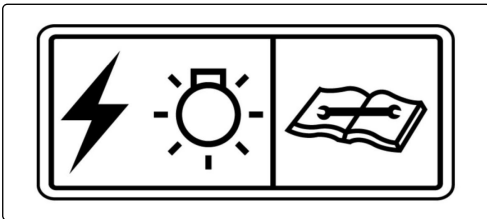

g03796564 DEF Purge Indicator Lamp

For machines not equipped with a circuit that stays activated for DEF purge with the disconnect switch off:

Figure 36.

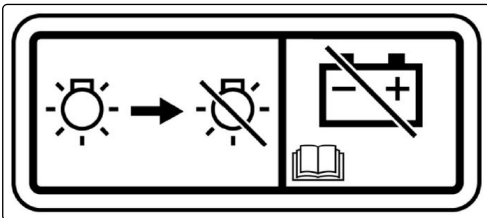

g03408962 DEF Purge Indicator Lamp-Circuit Not Activated for DEF Purge



IMPORTANT

After the engine is shutdown, apply the battery disconnect switch. Applying the battery disconnect too soon will prevent the DEF system from being purged and could cause DEF to freeze in the lines.

4.3.3.3. Air Conditioner (10)*

These messages are positioned on the left door behind the cab.

Figure 37.

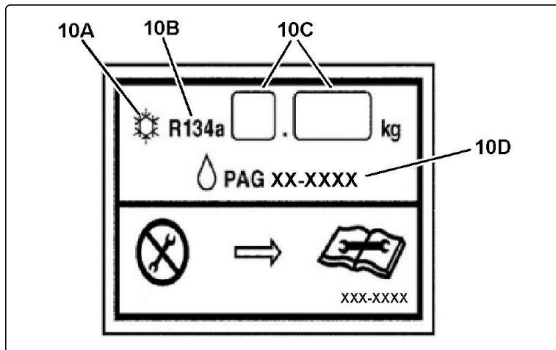

g06214936 Air Conditioning Decal

- (10A) Air conditioning symbol
- (10B) R134a (Refrigerant type common name)
- (10C) Refrigerant quantity
- (10D) PAG (polypropylene glycol) lubricating oil part number

Figure 38.

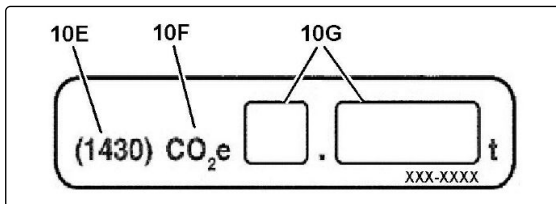

g06214938 Air Conditioning EU Plate 1

If equipped, this plate provides the below additional European Union-required greenhouse gas information.

- (10E) (1430) - This is the Global Warming Potential of R134a
- (10F) CO2 equivalent
- (10G) The system contains 1.430 metric tonnes of CO2 equivalent

Figure 39.



g06214940 Air Conditioning EU Plate 2

(10H) If equipped, this film provides the required language translations of the text "Contains fluorinated greenhouse gases" for the European Union greenhouse gas regulation.

These messages for the air conditioner system have the appropriate information for the following services: the air conditioner lubricant, the refrigerant charge, and the refrigerant capacity.

4.3.3.4. Engine Oil Requirements (11)*

This message is on top of the engine.

Figure 40.

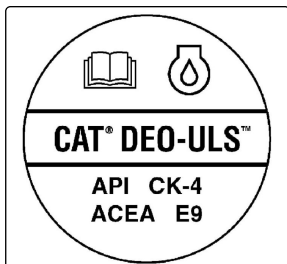

g06208149 Engine Oil Requirements

Tier 4 Engines

4.3.3.5. Diesel Fuel Requirements (12)*

This message is located by the fuel tank.

Figure 41.

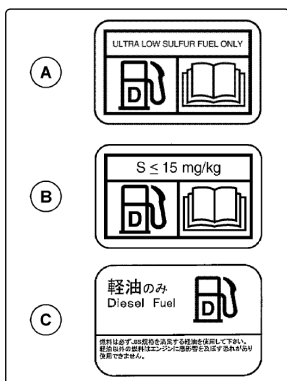

g03218956 Diesel Fuel Requirements

- (A) North America film
- (B) Europe, Africa, Middle East film
- (C) Japan film

4.3.3.6. Hydraulic Oil Level Check (13)

This message is located in the right access compartment next to the sight gauge for the hydraulic oil.

Check the hydraulic oil level daily.

See [Section: "Checking the Hydraulic System Oil Level*" \(page 462\)](#) for more information.

4.4. HAZARD PREVENTION



NOTICE

CZM cannot foresee all the circumstances that may involve a hazard. Therefore, the hazard alerts in this manual and on the drilling rig may not include all possible safety precautions.

4.4.1. Health and First Aid

Figure 42.



0000402 First Aid

- At each construction site, at least one operator for each team must be trained to be able to intervene in case of an accident;
- Training must be entrusted to competent and experienced staff;
- The designated operator must know how to recognize and provide for the first intervention, in case of:
 - eye injuries;
 - cuts;
 - bruises;
 - abrasions to the skin surface;
 - fractures,
 - burns;
 - inhalation of toxic materials;
 - collapses;
 - heart attacks;
 - electric shocks.

4.4.1.1. Contact With Fluids

- If you are injured by a fluid leak, seek immediate medical attention. If proper treatment is not taken immediately, infections or serious reactions could arise.
- Avoid skin contact with any kind of fuel, lubricant, acid, solvent, etc., since most of them contain substances that can be harmful to health.
- Avoid prolonged and repeated contact of the skin with used motor oils, such contact can cause serious skin diseases or other serious physical injuries.
- A jet of fuel or oil at high pressure can cause serious physical injury.
- The anti-corrosion contains an alkaline substance:
 - Avoid contact with the eyes. In case of contact with the eyes, immediately rinse the eyes with plenty of running water for at least 15 minutes and seek medical attention immediately.
 - Avoid prolonged and repeated contact with skin.
 - Do not ingest the product.
- Diesel fuel and methylethylketone ketone (MEK) are flammable substances and must be used with caution.
- Follow the manufacturer's instructions to ensure maximum safety.

- If any coolant gets into your eyes, wash them immediately in cold water for at least 5 minutes and seek medical attention immediately.
- If any coolant gets on your skin, use the same treatment for freezing. Warm the affected area with your hand or with warm water, cover it with a loose bandage to protect the affected area from infections, and seek medical attention immediately.
- Batteries contain sulfuric acid. Protect your eyes when working near batteries to avoid possible splashing of the acid solution. If the acid comes into contact with the skin, eyes, or clothes, rinse immediately with water for a minimum of 15 minutes. Seek immediate medical attention.

4.4.1.2. Electrocution

In case of an emergency and awaiting the arrival of medical personnel, apply the following general instructions for providing first aid:

- Do not touch the injured person with bare hands until you are sure that he can be detached from the tension.
- Cancel the tension if the injured person is still under tension.
- Do not give liquids to the injured person under any circumstances.

4.4.2. Pressurized Lines*

The drilling rig operates with high-pressure hydraulic oil hoses.

- Check lines, tubes, and hoses carefully.
- Wear Personal Protection Equipment (PPE) (see [Personal Protective Equipment \(PPE\) \(page 69\)](#)).
- Never use your hands to check or feel for leaks. Always use a board or cardboard when you check for a leak.

Figure 43.

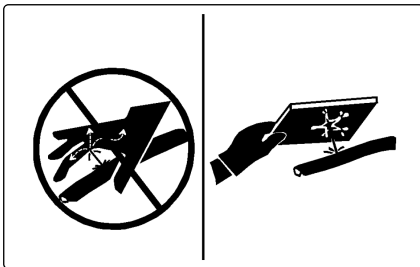

g00687600 Fluid Penetration



WARNING

- Pressurized hydraulic oil may be hot and could cause burns.
- The hydraulic oil tank may be under pressure, and hydraulic oil may be present at the filler cap. Allow the hydraulic system to cool and relieve hydraulic system pressure before maintenance to prevent injury.
- Do not bend high-pressure lines.
- Do not strike high-pressure lines.
- Do not install any lines that are bent or damaged.

4.4.2.1. Fuel Lines*

SMCS Code: 1000; 1274; 7000



WARNING

- Contact with high-pressure fuel may cause fluid penetration and burn hazards.
- High-pressure fuel spray may cause a fire hazard.

Failure to follow this warning could result in death or serious injury.

The high-pressure fuel lines are the fuel lines that are between the high-pressure fuel pump and the high-pressure fuel manifold and the fuel lines that are between the fuel manifold and cylinder head. These fuel lines are different from fuel lines on other fuel systems.

This is because of the following differences:

- The high-pressure fuel lines are constantly charged with high pressure.
- The internal pressures of the high-pressure fuel lines are higher than other types of fuel systems.
- The high-pressure fuel lines are formed to shape and then strengthened by a special process.

Consequently:

- Do not step on the high-pressure fuel lines.
- Do not deflect the high-pressure fuel lines.
- Do not bend or strike the high-pressure fuel lines.

**IMPORTANT**

Deformation or damage of the high-pressure fuel lines may cause a point of weakness and potential failure.

- Do not check the high-pressure fuel lines with the engine or the starting motor in operation.

**IMPORTANT**

After the engine has stopped, allow 10 minutes for the pressure to be purged before any service or repair is performed on the engine fuel lines.

- Do not loosen the high-pressure fuel lines to remove air from the fuel system. This procedure is not required.
- Visually inspect the high-pressure fuel lines before the engine is started. This inspection should be each day.

If you inspect the engine in operation, always use the proper inspection procedure to avoid a fluid penetration hazard:

- Inspect the high-pressure fuel lines for damage, deformation, a nick, a cut, a crease, or a dent.
- Do not operate the engine with a fuel leak. If there is a leak do not tighten the connection to stop the leak. The connection must only be tightened to the recommended torque. Refer to Disassembly and Assembly for your engine.
- If the high-pressure fuel lines are torqued correctly and the high-pressure fuel lines are leaking, the high-pressure fuel lines must be replaced.
- Ensure that all clips on the high-pressure fuel lines are in place. Do not operate the engine with clips that are damaged, missing, or loose.
- Do not attach any other item to the high-pressure fuel lines.
- Loosened high-pressure fuel lines must be replaced. Also removed high-pressure fuel lines must be replaced. Refer to Disassembly and Assembly for your engine.

4.4.2.2. Accumulators

This machine is equipped with an accumulator charged with high-pressure nitrogen gas. Do not disassemble the accumulator.

- Never expose the accumulator to temperatures over 140°F (60°C) or to open flames.
- Never weld on the accumulator.
- Never strike the accumulator.

**WARNING**

Hydraulic accumulators contain nitrogen gas and hydraulic oil under high pressure.

- DO NOT disconnect lines or disassemble any component of a pressurized accumulator.
- All gas pre-charge must be removed from the accumulator as instructed by this manual before servicing or disposing of the accumulator or any accumulator component.
- Only use dry nitrogen gas to recharge accumulators.

Failure to follow this warning could result in death or serious injury.

4.4.2.3. Track*

SMCS Code: 4170; 7000

Track adjusting systems use either grease or oil under high pressure to keep the track under tension.

Watch the track or track adjustment cylinder to see if the track is being loosened.

**WARNING**

Track adjusting systems use either grease or oil under high pressure to keep the track under tension.

Grease or oil under high pressure coming out of the relief valve can penetrate the body causing injury or death.

- Do not watch the relief valve to see if grease or oil is escaping. Watch the track or track adjustment cylinder to see if the track is being loosened.
- During the greasing operation, do not stand in front of the inspection panel.



- Loosen the relief valve for one turn only.
- If the track does not loosen, close the relief valve and contact CZM.
- The pins and bushings in a dry track pin joint can become very hot. It is possible to burn the fingers if there is more than brief contact with these components.

The pins and bushings in a dry track pin joint can become very hot. It is possible to burn the fingers if there is more than brief contact with these components.

4.4.2.4. Air and Water*

- Pressurized air and/or water can cause debris and/or hot water to be blown out. The debris and/or hot water could result in personal injury.
- When pressurized air and/or pressurized water is used for cleaning, wear protective clothing, protective shoes, and eye protection. Eye protection includes goggles or a protective face shield.
- The maximum air pressure for cleaning purposes must be reduced to 205 kPa (30 psi) when the nozzle is deadheaded and the nozzle is used with an effective chip deflector and personal protective equipment.
- The maximum water pressure for cleaning purposes must be below 275 kPa (40 psi).
- Avoid direct spraying of water on electrical connectors, connections, and components. When using air for cleaning, allow the machine to cool to reduce the possibility of fine debris igniting when redeposited on hot surfaces.

4.4.2.5. Trapped Pressure*

Figure 44.



0000412 Pressurized Cylinder

Pressure can be trapped in a hydraulic system:

WARNING
 Fluid penetration can cause serious injury and possible death.
 If you are injured by a fluid leak, seek immediate medical attention. If proper treatment is not taken immediately, infections or serious reactions could arise.

- Never perform repairs to items while any system is under pressure.
- Releasing trapped pressure can cause sudden machine movement or attachment movement.
- Use caution if you disconnect hydraulic lines or fittings.
- High-pressure oil that is released can cause a hose to whip.
- High-pressure oil that is released can cause oil to spray.

4.4.2.6. Fluid Penetration*

Figure 45.

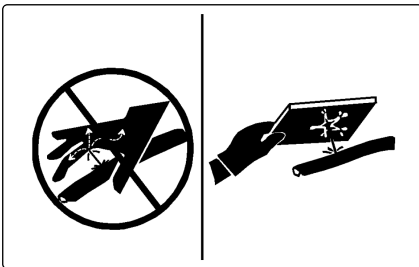

g00687600 Fluid Penetration

Pressure can be trapped in the hydraulic circuit long after the machine has been stopped:

- The pressure can cause hydraulic fluid or items such as pipe plugs to escape rapidly if the pressure is not relieved correctly.
- Do not remove any hydraulic components or parts until the pressure has been relieved or personal injury may occur.
- Do not disassemble any hydraulic components or parts until the pressure has been relieved or personal injury may occur.
- Never use your hands to check or feel for leaks. Always use a board or cardboard when you check for a leak.

WARNING
 Fluid penetration can cause serious injury and possible death.
 If you are injured by a fluid leak, seek immediate medical attention. If proper treatment is not taken immediately, infections or serious reactions could arise.

4.4.2.7. Containing Fluid Spillage*

- Care must be taken to ensure that fluids are contained during the performance of inspection, maintenance, testing, adjusting, and repair of the equipment.
- Prepare to collect the fluid with suitable containers before opening any compartment or disassembling any component that contains fluids;
- Obey all local regulations for the disposal of liquids.

4.4.3. Inhalation*

Figure 46.

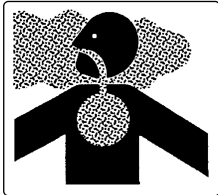

g02159053 Inhalation

4.4.3.1. Exhaust



WARNING

Use caution. Exhaust fumes can be hazardous to your health. If you operate the machine in an enclosed area, adequate ventilation is necessary.

4.4.3.2. Asbestos

Use the following guidelines when you handle any replacement parts that contain asbestos or when you handle asbestos debris.



WARNING

Avoid inhaling dust that might be generated when you handle components that contain asbestos fibers. Inhaling this dust can be hazardous to your health.

The components that may contain asbestos fibers are:

- brake pads.
- brake bands.
- lining material.
- clutch plates.
- some gaskets.



NOTICE

The asbestos that is used in these components is bound in a resin or sealed in some way. Normal handling is not hazardous unless airborne dust that contains asbestos is generated.

If dust that may contain asbestos is present, several guidelines should be followed:

- Never use compressed air for cleaning.
- Avoid brushing materials that contain asbestos.
- Avoid grinding materials that contain asbestos.
- Use a wet method to clean up asbestos materials.
- A vacuum cleaner that is equipped with a high-efficiency particulate air filter (HEPA) can also be used.
- Use exhaust ventilation on permanent machining jobs.

- Wear an approved respirator if there is no other way to control the dust.
- Comply with applicable rules and regulations for the workplace. In the United States, use Occupational Safety and Health Administration (OSHA) requirements. These OSHA requirements can be found in “29 CFR 1910.1001”.
- Obey environmental regulations for the disposal of asbestos.
- Stay away from areas that might have asbestos particles in the air.

4.4.3.3. Hexavalent Chromium Information*

Hexavalent chromium has occasionally been detected on exhaust and heat shield systems on Cat engines. Although lab testing is the only accurate way to know if hexavalent chromium is, in fact, present, the presence of a yellow deposit in areas of high heat (for example, exhaust system components or exhaust insulation) may be an indication of the presence of hexavalent chromium.

Use caution if you suspect the presence of hexavalent chromium. Avoid skin contact when handling items that you suspect may contain hexavalent chromium, and avoid inhalation of any dust in the suspect area. Inhalation of, or skin contact with, hexavalent chromium dust may be hazardous to your health.

If such yellow deposits are found on the engine, engine component parts, or associated equipment or packages, it is recommended to follow local health and safety regulations and guidelines, utilizing good hygiene, and adhering to safe work practices when handling the equipment or parts. Caterpillar also recommends the following:

- Wear appropriate personal protective equipment (PPE).
- Wash your hands and face with soap and water prior to eating, drinking, or smoking, and also during rest room breaks, to prevent ingestion of any yellow powder.
- Never use compressed air for cleaning areas suspected of containing hexavalent chromium.
- Avoid brushing, grinding, or cutting materials suspected of containing hexavalent chromium.
- Obey environmental regulations for the disposal of all materials that may contain or have come into contact with hexavalent chromium.
- Stay away from areas that might have hexavalent chromium particles in the air.

4.4.4. Crushing and Cutting*

SMCS Code: 7000

Figure 47.



0000407 Crushing

- Support the equipment properly before you perform any work or maintenance beneath that equipment. Do not depend on the hydraulic cylinders to hold up the equipment. Equipment can fall if the control is moved, or if a hydraulic line breaks.
- Do not work beneath the cab of the machine unless the cab is properly supported.
- Unless you are instructed otherwise, never attempt adjustments while the machine is moving or while the engine is running.
- Never jump across the starter solenoid terminals to start the engine. Unexpected machine movement could result.
- Whenever there are equipment control linkages, the clearance in the linkage area will change with the movement of the equipment or the machine. Stay clear of areas that may have a sudden change in clearance with machine movement or equipment movement.
- Stay clear of all rotating and moving parts.

- If it is necessary to remove guards to perform maintenance, always install the guards after the maintenance is performed.
- Keep objects away from moving fan blades. The fan blade will throw objects or cut objects.
- Do not use a kinked wire cable or a frayed wire cable. Wear appropriate gloves when you handle wire cables.
- When you strike a retainer pin with force, the retainer pin can fly out. The loose retainer pin can injure personnel. Make sure that the area is clear of people when you strike a retainer pin. To avoid injury to your eyes, wear protective glasses when you strike a retainer pin.
- Chips or other debris can fly off an object when you strike the object. Make sure that no one can be injured by flying debris before striking any object.

4.4.5. Burn*

SMCS Code: 7000

Figure 48.



0000411 Hot Surface

- Do not touch any part of an operating engine.
- Allow the engine to cool before any maintenance is performed on the engine.
- Relieve all pressure in the air system, in the oil system, in the lubrication system, in the fuel system, or in the cooling system before any lines, fittings, or related items are disconnected.

4.4.5.1. Coolant

- When the engine is at operating temperature, the engine coolant is hot. The coolant is also under pressure.
- The radiator and all lines to the heaters or the engine contain hot coolant.
- Check the coolant level only after the engine has been stopped.
- Ensure that the filler cap is cool before removing the filler cap. The filler cap must be cool enough to touch with a bare hand. Remove the filler cap slowly in order to relieve pressure.
- Do not attempt to tighten hose connections when the coolant is hot, the hose can come off causing burns.



WARNING

- Any contact with hot coolant or with steam can cause severe burns. Allow cooling system components to cool before the cooling system is drained.
- The cooling system conditioner contains alkali. Alkali can cause personal injury. Do not allow alkali to contact the skin, the eyes, or the mouth.

4.4.5.2. Oils



WARNING

- Hot oil and hot components can cause personal injury.
- Do not allow hot oil to contact the skin.
- Also, do not allow hot components to contact the skin.

- Remove the hydraulic tank filler cap only after the engine has been stopped. The filler cap must be cool enough to touch with a bare hand.

- Follow the standard procedure in this manual to remove the hydraulic tank filler cap.

4.4.5.3. Batteries

Figure 49.



0000410 Corrosive Substance



WARNING

The liquid in a battery is an electrolyte. The electrolyte is an acid that can cause personal injury.

- Do not allow electrolytes to contact the skin or the eyes.
- Do not smoke while checking the battery electrolyte levels. Batteries give off flammable fumes which can explode.

- Always wear protective glasses and gloves when you work with batteries.
- Wash hands after touching batteries without gloves.

4.4.6. Fire and Explosion*

SMCS Code: 7000

Figure 50.

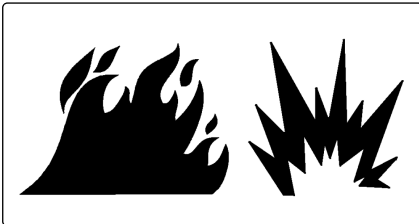

g0074000 Fire and Explosion

All fuels, most lubricants, and some coolant mixtures are flammable. To minimize the risk of fire or explosion, follow these actions:

- Always perform a Walk-Around Inspection, which may help you identify a fire hazard. Do not operate a machine when a fire hazard exists.



WARNING

- Do not operate a machine with a fluid leak.
- Repair leaks and clean up fluids before resuming machine operation.
- Fluids that are leaking or spilled onto hot surfaces or electrical components can cause a fire. A fire may cause personal injury or death.

- Understand the use of the primary exit and emergency exit on the machine. Refer to *“Emergency Exit”* (page 102).
- Remove flammable materials such as leaves, twigs, papers, trash, and so on. These items may accumulate in the engine compartment or around other hot areas and hot parts on the machine.
- Keep the access doors to major machine compartments closed and access doors in working condition to permit the use of fire suppression equipment, in case a fire should occur.

- Clean all accumulations of flammable materials such as fuel, oil, and debris from the machine.
- Do not operate the machine near any flame.
- Keep shields in place. Exhaust shields (if equipped) protect hot exhaust components from oil spray or fuel spray in a break in a line, in a hose, or a seal. Exhaust shields must be installed correctly.
- Do not weld or flame cut on tanks or lines that contain flammable fluids or flammable material:
 1. Empty and purge the lines and tanks.
 2. Clean the lines and tanks with a nonflammable solvent before welding or flame cutting.
 3. Ensure that the components are properly grounded to avoid unwanted arcs.
- Dust that is generated from repairing nonmetallic hoods or fenders may be flammable and/or explosive. Repair such components in a ventilated area away from open flames or sparks. Use suitable Personal Protection Equipment (PPE) (see [Personal Protective Equipment \(PPE\) \(page 69\)](#)).
- Inspect all lines and hoses for wear or deterioration. Replace damaged lines and hoses. The lines and the hoses should have adequate support and secure clamps. Tighten all connections to the recommended torque. Damage to the protective cover or insulation may provide fuel for fires.
- Store fuels and lubricants in properly marked containers away from unauthorized personnel. Store oily rags and flammable materials in protective containers. Do not smoke in areas that are used for storing flammable materials.

4.4.6.1. Regeneration*

The exhaust gas temperatures during regeneration will be elevated.

Follow proper fire prevention instructions and use the disable regeneration function (if equipped) when appropriate.

4.4.6.2. Fueling*

Figure 51.



g03839130 Fueling

Use caution when you are fueling a machine:

- Do not smoke while you are fueling a machine.
- Do not fuel a machine near open flames or sparks.
- Do not use cell phones or other electronic devices while you are refueling.
- Always stop the engine before fueling. Fill the fuel tank outdoors.
- Properly clean areas of spillage.
- Never store flammable fluids in the operator compartment of the machine.

Avoid static electricity risk when fueling. Ultra-low sulfur diesel (ULSD) poses a greater static ignition hazard than earlier diesel formulations with higher sulfur content:

- Avoid death or serious injury from fire or explosion.
- Consult with your fuel or fuel system supplier to ensure that the delivery system complies with fueling standards for proper grounding and bonding practices.

4.4.6.3. Battery and Battery Cables*

Figure 52.



g03839133 Battery and Battery Cables

Follow these instructions to minimize the risk of fire or an explosion related to the battery:

- Do not operate a machine if battery cables or related parts show signs of wear or damage.
- Follow safe procedures for the engine starting with jumpstart cables. Improper jumper cable connections can cause an explosion that may result in injury.
- Do not charge a frozen battery. This may cause an explosion.
- Gases from a battery can explode. Keep any open flames or sparks away from the top of a battery.
- Do not smoke in battery charging areas. Do not use cell phones or other electronic devices in battery charging areas.
- Never check the battery charge by placing a metal object across the terminal posts. Use a voltmeter to check the battery charge.
- Daily inspect battery cables that are in visible areas. Inspect cables, clips, straps, and other restraints for damage. Replace any damaged parts. Check for signs of the following, which can occur over time due to use and environmental factors:
 - a. Fraying.
 - b. Abrasion or wear.
 - c. Cracking.
 - d. Discoloration.
 - e. Cuts on insulation.
 - f. Fouling.
 - g. Corroded terminals, damaged terminals, and loose terminals.
- Replace damaged battery cable(s) and replace any related parts. Eliminate any fouling, which may have caused insulation failure or related component damage or wear. Ensure that all components are reinstalled correctly.
- An exposed wire on the battery cable may cause a short to ground if the exposed area comes into contact with a grounded surface. A battery cable short produces heat from the battery current, which may be a fire hazard.
- An exposed wire on the ground cable between the battery and the disconnect switch may cause the disconnect switch to be bypassed if the exposed area comes into contact with a grounded surface. This may result in an unsafe condition for servicing the machine. Repair components or replace components before servicing the machine.



WARNING

Exposed battery cables that come into contact with a grounded connection can result in fires. Replace cables and related parts that show signs of wear or damage.

4.4.6.4. Wiring*

Check electrical wires daily.

- Keep wiring and electrical connections free of debris.
- Do not attach electrical wiring to hoses and tubes that contain flammable fluids or combustible fluids.
- If any of the following conditions exist, replace parts before you operate the machine:
 - a. Fraying.
 - b. Abrasion or wear.
 - c. Cracking.
 - d. Discoloration.
 - e. Cuts on insulation.
 - f. Other damage.
- Make sure that all clamps, guards, clips, and straps are reinstalled correctly. This will help to prevent vibration, rubbing against other parts, and excessive heat during machine operation.

4.4.6.5. Ether*

Ether (if equipped) is commonly used in cold-weather applications.

- Ether is flammable and poisonous. Use ether with care to avoid fires.
- Only use approved Ether canisters for the Ether dispensing system fitted to your machine, do not spray Ether manually into an engine and follow the correct cold engine starting procedures. For more information refer to [Section: "Starting the Machine" \(page 266\)](#)



WARNING

Manually spraying Ether into an engine with a Diesel Particulate Filter (DPF) may result in the accumulation of Ether in the DPF and an explosion.

Failure to follow this warning could result in death or serious injury.

- Use ether only in well-ventilated areas.
- Do not smoke while replacing an ether cylinder.
- Do not store ether cylinders in living areas or in the operator compartment of a machine.
- Do not store ether cylinders in direct sunlight or temperatures above 49° C (120.2° F).
- Keep ether cylinders away from open flames or sparks.
- Discard cylinders in a safe place. Do not puncture or burn cylinders.
- Keep ether cylinders out of the reach of unauthorized personnel.



ENVIRONMENTAL NOTICE

Dispose of used ether cylinders properly.

4.4.6.6. Fire Extinguisher

SMCS Code: 7000; 7419

Figure 53.



0000403 Fire Extinguisher

- Keep a fire extinguisher on the machine.
- Be familiar with the operation of the fire extinguisher.
- Inspect the fire extinguisher and service the fire extinguisher regularly.
- Obey the recommendations on the instruction plate.

- Consider the installation of an aftermarket Fire Suppression System, if the application and working conditions warrant the installation.

The recommended location for mounting the fire extinguisher is on the upper handrail on the right side of the machine.

Figure 54.

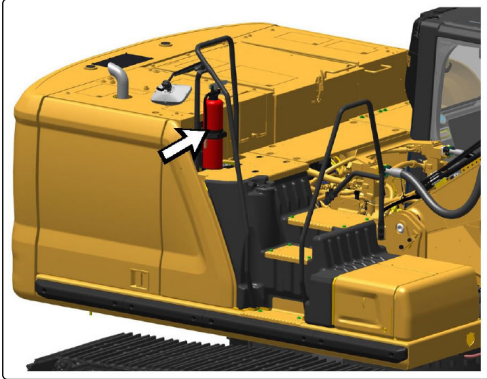

g06188176 Fire Extinguisher Location

4.4.6.7. In Case of Fire

SMCS Code: 7000



IMPORTANT

Locate the emergency exit and how to use it before you operate the machine.



IMPORTANT

Locate the fire extinguisher and how to use it before you operate the machine.

If you find that you are involved in a machine fire, your safety and that of others on site are the top priority.

The following actions should only be performed if the actions do not present a danger or risk to you and any nearby people.

Assess the risk of personal injury and move away to a safe distance as soon as you feel unsafe.

1. Move the machine away from nearby combustible material such as fuel/oil stations, structures, trash, mulch, and timber.
2. Lower any equipment and turn off the engine as soon as possible. If you leave the engine running, the engine will continue to feed a fire. The fire will be fed from any damaged hoses that are attached to the engine or pumps.
3. If possible, turn the battery disconnect switch to the OFF position. Disconnecting the battery will remove the ignition source in the event of an electrical short. Disconnecting the battery will eliminate a second ignition source if electrical wiring is damaged by the fire, resulting in a short circuit.
4. Notify emergency personnel of the fire and your location.
5. If your machine is equipped with a fire suppression system, follow the manufacturer's procedure for activating the system.



IMPORTANT

Fire suppression systems need to be regularly inspected by qualified personnel.
You must be trained to operate the fire suppression system.

6. If you are unable to do anything else, shut off the machine before exiting. By shutting off the machine, fuels will not continue to be pumped into the fire.
7. If the fire grows out of control, be aware of the following risks.
 - Tanks, accumulators, hoses, and fittings can rupture in a fire, spraying fuels and shrapnel over a large area.
 - Remember that nearly all the fluids on the machine are flammable, including coolant and oils.
 - Additionally, plastics, rubbers, fabrics, and resins in fiberglass panels are also flammable.

4.4.7. Electrical Storm Injury*

SMCS Code: 7000

Figure 55.

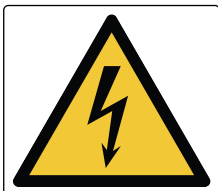

0000409 Electricity

When lightning is striking in the vicinity of the machine, the operator should never attempt the following procedures:

- Mount the machine.
- Dismount the machine.

If you are in the operator's cab during an electrical storm, stay in the operator's cab.
 If you are on the ground during an electrical storm, stay away from the vicinity of the machine.

4.4.8. Snow and Ice

Figure 56.



0000405 Low Temperature-Freezing Conditions

! IMPORTANT
 Remove snow and ice from the machine, in particular from safety devices such as sensors and limit switches.

Snow and ice deposits on the machine can:

- Cause unwanted effects on the machine.
- Increase the danger of the work area: danger of falling ice fragments and blocks of snow.

4.4.9. Dust

- The diffusion of dust must be minimized by periodically spraying the work surfaces and the paths of the mechanical means.
- Wear Personal Protection Equipment (PPE) (see [Personal Protective Equipment \(PPE\) \(page 69\)](#)).
- Close the door and windows of the cab. Activate the air conditioning system for adequate ventilation.
- Read and understand the Safety Data Sheet (SDS) for guidelines on the exposure risks, PPE required, proper handling and cleanup, and the correct reporting agencies if needed.

4.4.10. Chemicals

Figure 57.



0000410 Corrosive Substance

Chemicals at a job site present a serious danger when they are released or mishandled.

- Wear Personal Protection Equipment (PPE) (see [Personal Protective Equipment \(PPE\) \(page 69\)](#)).
- Read and understand the Safety Data Sheet (SDS) for guidelines on the exposure risks, PPE required, proper handling and cleanup, and the correct reporting agencies if needed.

4.4.11. Suspended Loads and Falling Objects

Figure 58.



0000406 Suspended Loads

- The work area must be delimited to avoid people approaching the machine during assembly, maintenance, and use.
- Periodically check the tightening of the joints, bolts, pins, and anything else subject to be loosened during use.
- Do not stand under any suspended load when using the auxiliary winch to lift authorized drilling rig equipment.
- Make sure suspended loads are safely controlled during lifting operations.
- Any guiding of loads with ropes or rods must be at a distance of at least 2 meters from the suspended loads.
- Keep hands away from the kelly bar and other moving drilling rig components.
- The handling of the reinforcements must be carried out with suitable lifting equipment using the attachment points provided by the manufacturer. Use suitable harness straps and/or ropes and check them periodically.
- The hooks must be equipped with devices against accidental release.

4.5. WORK AREA



IMPORTANT

The work area must comply with the safety laws in force in the country where the machine works.

4.5.1. General Rules

Figure 59.



0000413 No Thoroughfare

- The work area must be delimited with barriers, including mobile, rigid, or flexible (tapes), and appropriately marked.
- Access to unauthorized personnel must be prevented.
- Keep the work area tidy, objects left unattended can prevent and make unsafe the movement of personnel and machine.
- Fixed obstacles must be marked and/or protected (the top of finished piles, reinforcements protruding from the ground, etc.).
- An adequate lighting system must be set up in the work area. It must be implemented in compliance with the laws in force in the country in which the machine is working.
- If you are operating near airports, respect the laws in force. Contact the competent authorities and, if necessary, contact CZM to make the necessary changes.

4.5.2. Overhead and Underground Obstacles

- Make sure of the exact path of both overhead and underground obstacles.
- These paths must be appropriately delimited by the competent authorities.
- If necessary, request the interruption of the service or the relocation of the systems before starting work.
- Request the presence of an assistant, who can observe the approach of the equipment to the area from a better point of view than the operator.

4.5.2.1. Distance from Power Lines

- Keep the maximum possible distance from the power line to avoid electrical hazards.
- Always complete a risk assessment to identify any overhead and buried power lines in the work area before beginning work.
- Eliminate any risks arising from working near overhead and buried power lines. If you cannot eliminate a risk then you must put controls in place to minimize it.
- Regularly review your property's risk plan for working near overhead power lines.
- Treat all overhead and buried power lines as being energized and not insulated.

**DANGER**

- The minimum distances to be respected can change according to the Country where the machine is working. it is mandatory to comply with the national laws in force.
- Avoid direct contact with high-voltage power lines while operating.
- Overhead power lines carry high-voltage electricity that can discharge to the ground through the drilling rig, with or without direct contact with the drilling rig structure.

Failure to follow this warning will cause serious injury or death.

Figure 60.



0000226 Power Lines

4.5.2.1.1. United States Safety Distance

The distances indicated in the following table are valid for the UNITED STATES as reported by the American Regulations of the O.S.H.A. (Occupational Safety & Health Administration).

Table 3. USA Power Lines Distance

FPL Power Line Voltages	OSHA Minimum Approach Distance* (OSHA 1926.1408 Table A)
0 to 50kV	10 ft
Over 50kV to 200kV	15 ft
Over 200kV to 350kV	20 ft
Over 350kV to 500kV	30 ft
Over 500kV to 750kV	35 ft

*Minimum distance for travel under power lines must comply with OSHA Rules.

4.5.3. Soil Conditions

- Always examine the area for any hazardous conditions. Some examples are slopes, overhanging areas, trees, ravines, crags, rough terrain, ditches, ridges, ridges, excavations, etc. If similar conditions exist, proceed with extreme caution.
- It is possible to find soft ground conditions near newly built walls.
- The overlay material and the weight of the machine can cause the wall under the machine to collapse.
- It is necessary to know the load limitations of the ground, of the paving, of the ramps on which to operate.
- Check what is the maximum pressure expected under the track in the worst conditions. The ground on which the machine is to be positioned must withstand the maximum load-bearing capacity.
- Make sure that the ground on which the machine will rest is solid enough not to compromise stability. If the ground does not give sufficient guarantees of solidity, prepare adequate support plates.



WARNING

- Performing drilling operations or moving the machine on unstable or uneven ground could result in a tip-over.
- Make sure to continuously monitor the area around the machine.
- Do not exceed the indicated limits.

Failure to follow this warning could result in death or serious injury.

4.5.3.1. Soil Classification

The Occupational Health & Safety Administration (OSHA) classifies soils into four categories (in decreasing order of strength):

- Stable Rock.
- Cohesive Soil Type A.
- Cohesive Soil Type B.
- Cohesive Soil Type C.

Relative strengths of the four soil classifications are measured using the metric Unconfined Compression Strength, expressed in tons per square foot.

Data on these soils are contained in the three tables below.

Table 4. STABLE ROCK (Unconfined Compressive Strength by Rock Type)

Rock Type	Unconfined Compressive Strength (tsf) Minimum	Unconfined Compressive Strength (tsf) Maximum
Schist	84	1,729
Sandstone	104	2,455
Shale	358	2,412
Limestone	369	3,894
Granite	505	3,383
Gneiss	882	2,620

Table 5. COHESIVE SOILS (Unconfined Compressive Strength by Soil Type)

OSHA Cohesive Soil Type	Soil Description	Unconfined Compressive Strength (tsf)
A	Clay, silty clay, sandy clay, clay loam. Some silty clay loam and sandy clay loam.	≥ 15
B	Granular cohesive soils such as angular gravel, silt, silt loam, sandy loam.	0.5-1.5
C	Granular soils such as gravel, sand, loamy sand, submerged soil. Soil from which water is freely seeping.	≤ 0.5

Table 6. CLAYS (Unconfined Compressive Strength by Consistency)

OSHA	Unconfined Compressive Strength (tsf)
Very Soft	0-0.25
Soft	0.25-0.5
Medium	0.5-1
Stiff	1-2
Very Stiff	2-4
Hard	>4

4.5.3.2. Soil Subsidence

In case of subsidence of the soil under the track of the machine, follow this procedure:

1. Immediately stop the activity.
2. Evacuate the surrounding area.
3. Proceed to consolidate the soil to restore the horizontality of the support surface and the verticality of the work surface.

4.5.3.3. Slopes and Ditches

In the presence of slopes or ditches, keep the tracks, the foot mast, or the stabilizers at a safe distance from the edge.

When these components exert pressure on the ground, it is important that they do not sink into the ground, or cause nearby excavations to collapse, as this could lead to the machine tipping over.

The safety distance (D) from the bottom of the embankment must be adequate for the height (H) of the embankment.

If the ground is good (loose ground, well compacted, sand, gravel, or coherent solid ground) the distance (D) must be equal to the height (H) of the slope (D:H=1:1). In case of doubt, the distance (D) must be double the height (H) of the slope (D:H=2:1).

Figure 61.

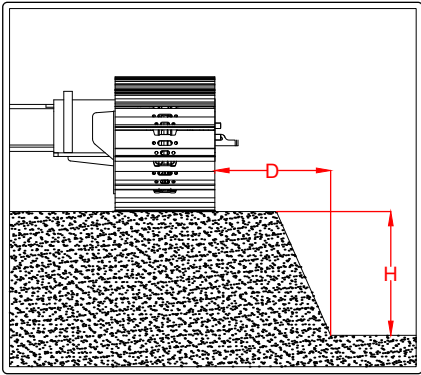

000414 Slopes and Ditches

4.6. OPERATION AND USE OF THE DRILLING RIG

4.6.1. Access to the Drilling Rig

The machine access system has been designed to meet the intent of the technical requirements in “ISO 2867 Earth-moving Machinery – Access Systems”. The access system provides for Operator access to the operator cab and to conduct the maintenance procedures described in the Maintenance section.

Figure 62.

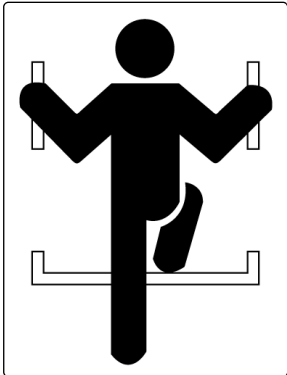

0000105 Mount and Dismount

Mounting or dismounting the base machine presents hazards. Observe the following:

- Mount and dismount only with the provided grab handles and steps by facing the base machine.
- Always maintain three-point contact (such as both feet and one hand, or one foot and both hands) using the grab handle and steps for proper safety and support.
- Wear personal protective (PPE) as required (see [Personal Protective Equipment \(PPE\) \(page 69\)](#)). Wear safety shoes with slip-resistant soles.
- Clean the sole of the shoes by removing mud or grease before getting on the machine.
- Do not walk on any surface of the drilling rig if the slip-resistant material is missing or excessively worn.
- Do not step on surfaces that are not approved for walking or working on.
- Always keep grab handles, steps, and walkway areas free of slipping hazards and debris. Repair or replace any damaged items immediately.
- Do not mount and dismount carrying tools or other things.
- Do not use the controls, hoses, or other parts of the machine as supports: these components are mobile and do not offer stable support. In addition, the involuntary movement of a command can cause accidental movement of the machine or equipment.
- Do not jump to mount or dismount the machine.
- Do not mount or dismount the machine while it is moving.
- Mount or dismount the machine only when it is completely stopped.



WARNING

Personnel may access the walkable areas of the machine only to carry out assembly and maintenance operations on the machine, respecting all the safety requirements indicated.



DANGER

It is forbidden to step, stand, or walk on the upper part of the base machine. Failure to follow this warning will cause serious injury or death.

**DANGER**

In addition to the operator in the cab, no other people must be on the machine during operation.

4.6.2. Workplace

The established workplace is the operator's cab, which is located in the position shown in the figure.

Figure 63.

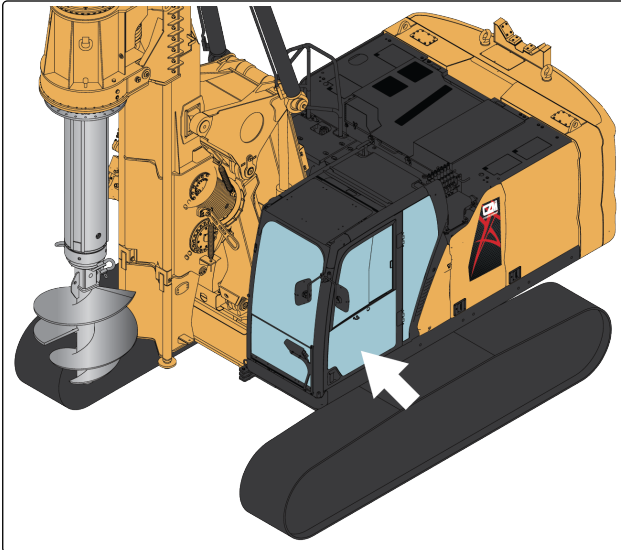

0000422 Workplace-Cab

**WARNING**

- Any modifications to the inside of the operator cab should not project into the operator space.
- Additional accessories such as a radio, fire extinguisher, and other equipment must be installed so that the defined operator space is maintained.
- Any item that is brought into the cab should not project into the defined operator space.
- A lunch box or other loose items must be secured. Objects must not pose an impact hazard in rough terrain or in the event of a rollover.
- With the machine running, the operator must not leave the cab.
- In addition to the operator in the cab, no other people must be on the machine during operation.
- Keep the cabin clean, both inside and outside.
- Keep access to the cabin free of obstacles.
- Keep the cab windows clean, not fogged, and free from ice.
- Do not place newspapers or other objects on the controls.
- Personal items or tools must not affect the use of the controls.

4.6.2.1. Emergency Exit

The cab is equipped with an emergency exit.

Figure 64.



0000401 Emergency Exit

4.6.2.1.1. Rear Window with Ring Seal (If Equipped)*

Figure 65.

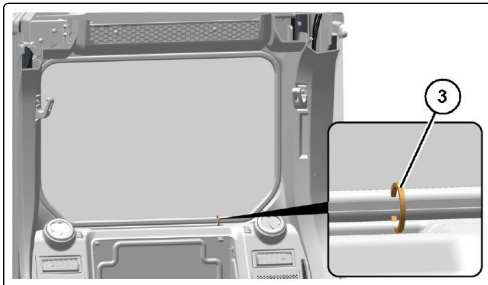

g06187008 Alternate Exit-Rear Window with Ring Seal

To remove the rear window:

1. Pull ring (3) and completely remove the window seal.
2. Push out the glass.
3. Climb through the rear window opening to exit the cab.

4.6.2.1.2. Rear Window with Lever (If Equipped)*

Figure 66.

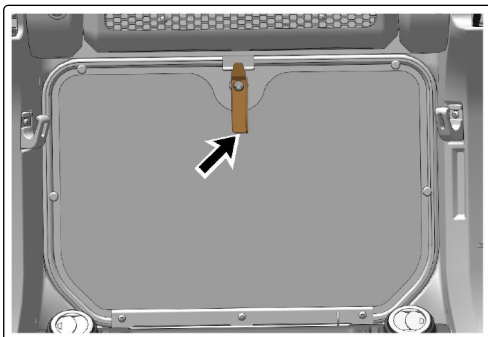

g06213470 Alternate Exit-Rear Window with Lever

To remove the rear window:

1. Rotate the handle from its latched position.
2. Push out the glass.
3. Climb through the rear window opening to exit the cab.

Figure 67.



g06213471 Alternate Exit-Rear Window with Lever 2

The window is also equipped with an outside handle. If the operator is unable to, outside personnel can rotate the outside handle and pull the window out.

4.6.2.2. Guards



WARNING

During drilling, objects could strike the front or top of the cab.

- The front and top guards must be installed on the cab.
- A daily inspection of the guards is required in order to check for structures that are bent, cracked, or loose. Never operate a machine with a damaged structure.

Failure to follow this warning could result in death or serious injury.

Observe the following guidelines:

- Keep all guards and safety devices in place.
- Restrict the area where the machine is being operated or maintenance is being performed.
- Keep all unnecessary personnel out of the work area.

4.6.3. Before Starting the Engine

SMCS Code: 1000; 7000



IMPORTANT

If a warning tag is attached to the engine start switch or the controls, do not start the engine. Also, do not move any controls.



WARNING

Diesel engine exhaust contains products of combustion which can be harmful to your health. Always run the engine in a well-ventilated area. If you are in an enclosed area, vent the exhaust to the outside.

- Carry out the checks provided by the manufacturer.
- Make sure that the maintenance operations have been carried out respecting the established intervals.
- Make sure you have sufficient fuel autonomy, to avoid the risk of a sudden engine stop, perhaps during a critical phase.
- Carry out a thorough cleaning of the instruments, plates, and lighting system.
- Make sure that all machine lights are working properly.
- Adjust and lock the seat in position, to ensure maximum comfort and usability of the controls.

- Inspect the condition of the seat belt and the mounting hardware. Replace any parts that are worn or damaged. Regardless of appearance, replace the seat belt after three years of use. Do not use a seat belt extension on a retractable seat belt.
- Fasten the seat belt securely.
- Be sure that all windows are clean. Secure the doors and the windows in the open position or in the shut position.
- Adjust all rear-view mirrors for visibility of the area.
- Make sure that all protections, fixed and movable guards, and covers are correctly mounted on the machine.
- Make sure that no one is underneath the machine, around the machine, or on the machine. Make sure that the area is free of personnel.
- Clear all obstacles from the machine's path. Beware of hazards (wires, ditches, etc).
- Make sure that you are seated before you start the engine.
- Check that all the controls are in the HOLD/NEUTRAL position.
- Move the hydraulic lockout control to the LOCKED position.
- Start the engine only from the Operator's workplace (refer to [Workplace \(page 101\)](#)). Never short across the starter terminals or across the batteries. Shorting could damage the electrical system by bypassing the engine neutral start system.
- Briefly sound the horn before you start the engine.

4.6.3.1. Machine Failure

- Do not start a faulty machine.
- Take an inspection tour around the machine before start-up.
- Before starting the machine, make sure that any conditions dangerous to safety have been appropriately eliminated.
- To move a faulty machine, use a trailer or another suitable transportation means.

4.6.4. Before Operation (Engine Started)

SMCS Code: 7000

- Warm up the engine and the hydraulic oil before operating the machine.



IMPORTANT

Do not operate the engine without engine coolant.

If the engine coolant expansion tank is empty, there may be an engine coolant leak. Inspect for engine coolant leaks and repair if found.

If a leak is not found, check for an internal leak.

Failure to follow this notice could result in damage to the engine or cause it to operate improperly.

- Do not operate a diesel engine where there are or can BE COMBUSTIBLE vapors. These vapors can be sucked through the air intake system and cause engine acceleration and over speeding that can result in a fire, an explosion, and extensive property damage. Numerous safety devices are available, such as air intake shutoff devices, to minimize the risk of over speeding where an engine, due to its application, is operating in a combustible environment, such as due to a fuel spill or gas leak. Remember, CZM has no way of knowing the use you have for your engine. The equipment owner and operator ARE responsible for safe operation in a hostile environment. Consult CZM After-Sales Department for further information.
- Pay attention in the presence of dust, smoke, or fog: bad visibility can cause dangerous use of the machine with possible serious damage to people.
- In dark conditions, carefully check the area before operating the machine.
- If the hydraulic devices are irregular in their stroke or abnormal in their response, have the machine checked for the presence of air in the system. The presence of air in these systems could cause incorrect movements with the consequent possibility of accidents.

- Make sure that the engine speed is adequate for the work you intend to perform.
- If the engine tends to slow down and stop under load or at idle, stop the machine and make any necessary repairs.
- Do not operate when one or more alarm lights are active: stop the machine and solve the problems.
- If a removable counterweight is equipped, do not use the machine if the counterweight has been disassembled.
- Do not add additional counterweights if they are not expressly provided for.
- Never leave the machine with the engine running.
- Before moving the machine, check the position of the undercarriage. The normal travel position is with the idler wheels to the front under the cab and the drive sprockets to the rear. When the undercarriage is in the reversed position, the directional controls must be operated in opposite directions.

4.6.5. Operation

- Check for proper operation of all controls and all protective devices while you operate the machine slowly in an open area.
- Never misuse, override, eliminate, or bypass any safety device. Failure to comply with this requirement can increase the risk to personal health and safety.
- Report any machine damage that was noted during machine operation. Make any necessary repairs.
- Never use the work tool for a work platform.
- Never lower the tools, accessories, or mast if they are out of the operator's view.
- Inform all job site personnel assisting with operations of the operations being performed to ensure safety.
- Be careful to avoid any ground condition which could cause the machine to tip. Tipping can occur when you work on hills, banks, or slopes. Tipping can also occur when you cross ditches, ridges, or other unexpected obstructions.
- When possible, operate the machine up slopes and down slopes with the final drive sprockets facing down the slope. Avoid operating the machine across the slope. Place the heaviest end of the machine uphill when you are working on an incline.
- Keep the machine under control. Do not overload the machine beyond capacity.
- Avoid changing the direction of travel on a slope. Changing the direction of travel on a slope could result in tipping or side slipping of the machine.
- Know the maximum dimensions of your machine.

4.6.5.1. Auxiliary Winch

The auxiliary winch must only be used to support work operations to handle the following objects:

- Kelly bars.
- Drilling tools.
- Casings.
- Reinforcements.
- Tremie Pipes.

Consequently:

- **THIS MACHINE IS NOT A CRANE**
- The auxiliary winch must be used exclusively for operations relating to the operation of the machine: assembly of some parts of the machine, equipment, and drilling/excavation components.
- It is strictly forbidden to use the auxiliary winch for lifting other equipment.
- It is strictly forbidden to use the auxiliary winch for lifting people.
- The lifting of any load, other than the equipment indicated above and unrelated to the drilling/excavation process, such as pallets, baskets, beams, and any other is strictly prohibited.
- Any other use of the auxiliary winch is strictly FORBIDDEN and is considered improper use of the work equipment.

- The auxiliary winch must not be considered as lifting and handling equipment of generic loads and therefore it is NOT a lifting device for which specific design characteristics or periodic checks expressly provided for by law are required.
- Do not travel with a suspended load.
- Do not drag loads with the auxiliary winch.
- Always respect instructions in the [Section: "Limits of Use" \(page 172\)](#).

4.6.5.2. Kelly Bar



WARNING

- Do not work under a raised rotary/kelly bar;
- Do not place hands between extended kelly bar sections;
- Do not place fingers in auger/kelly bar mounting holes to check alignment.

Failure to follow this warning could result in death or serious injury.

Installation of a kelly bar into the rotary or auger is a dangerous procedure.

Kelly bars have telescoping sections that may not be fully collapsed. Do not place hands close to kelly bar sections as they may collapse suddenly.

Figure 68.

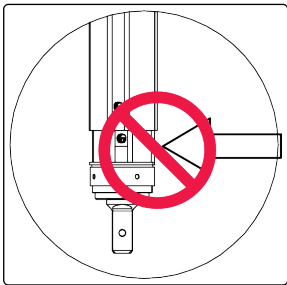

0000309 Kelly Bar Danger 1

If needed, use a pry bar to align the auger mounting hole with the kelly bar. Do not try to align holes with your hands.

Figure 69.

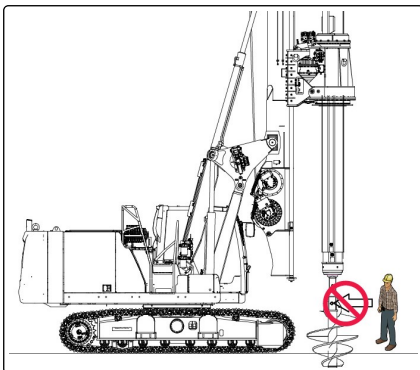

0000308 Kelly Bar Danger 2

Do not get under a suspended rotary and kelly bar.

During the installation of the kelly bar into the rotary, lower the rotary to the ground and check the kelly bar alignment at the top of the rotary.

Figure 70.

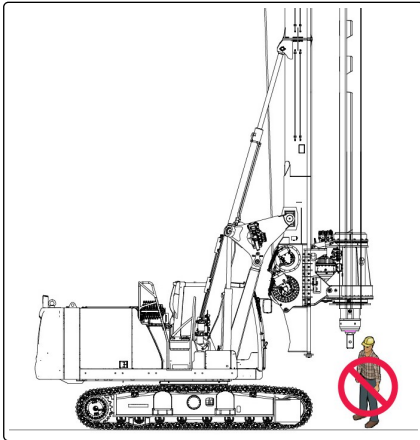

0000310 Kelly Bar Danger 3

4.6.5.3. Traveling

- Before moving the machine, check the position of the undercarriage. The normal travel position is with the idler wheels to the front under the cab and the drive sprockets to the rear. When the undercarriage is in the reversed position, the directional controls must be operated in opposite directions.
- Do not carry people on board the machine.
- For machines equipped with a variable undercarriage, make sure that it is opened in the maximum width position when moving.
- Do not travel the machine on the road.
- For machines not equipped with an acoustic signal, sound the horn before moving the machine.
- Always check the traveling area in search of any risk conditions.
- Do not cross or overcome obstacles such as severe irregularities in the ground, boulders, felled logs, steps, pits, ledges, and train tracks.
- Do not move the machine on slopes greater than those allowed.
- Do not travel on soils that are not sufficiently solid or not adequately prepared.
- Pay attention to possible variations in the grip which can cause loss of control of the machine.
- Ask for the help of a ground assistant when spaces are limited.
- The rough terrain could cause the oscillation of the mast, which could touch electrical lines or other obstacles.
- Travel with the headlights on and use appropriate signals and flags.
- When turning, consider the dimensions of the mast and the undercarriage.
- Travel with extreme caution on frozen ground or ice, on stepped ground, or in the vicinity of landslides.
- Know the dimensions of the machine in all configurations and set-ups to avoid obstacles.
- Study the best approach path to the work area.
- On steep descents, do not run the engine at high revs: choose the most suitable speed before facing the slope.
- If the machine slips sideways on an uphill slope, steer immediately with the front facing downwards.
- When traveling on slopes, always keep the machine base aligned with the undercarriage.
- When traveling on slopes, avoid changing direction.

4.6.5.4. Critical Failures*

The following table provides summary information on several limiting conditions found in this Operation and Maintenance Manual.

The table provides criteria and required action for the limiting conditions listed.

Each System or Component in this table, together with the respective limiting condition, describes a potential critical failure that must be addressed.

Not addressing limiting conditions with required actions may, in conjunction with other factors or circumstances, result in a risk of personal injury or death.

If an accident occurs, notify emergency personnel and provide the location and description of the accident.

Table 7. Critical Failures

System or Component Name	Limiting Condition	Criteria for Action	Required Action
Line, tubes, and hoses	End fittings are damaged or leaking. Outer coverings are chafed or cut. Wires are exposed. Outer coverings are swelling or ballooning. Flexible parts of the hoses are kinked. Outer covers have exposed embedded armoring. End fittings are displaced.	Visible corrosion, loose, or damaged lines, tubes, or hoses. Visible fluid leaks.	Immediately repair any lines, tubes, or hoses that are corroded, loose, or damaged. Immediately repair any leaks as these may provide fuel for fires.
Electrical Wiring	Signs of fraying, abrasion, cracking, discoloration, cuts on the insulation.	Visible damage to electrical wiring.	Immediately replace damaged wiring.
Battery cable(s)	Signs of fraying, abrasion, cracking, discoloration, cuts on the insulation of the cable, fouling, corroded terminals, damaged terminals, and loose terminals	Visible damage to battery cable(s)	Immediately replace damaged battery cables
Operator Protective Structure	Structures that are bent, cracked, or loose. Loose, missing, or damaged bolts.	Visible damage to structure. Loose, missing, or damaged bolts.	Do not operate machine with damaged structure or loose, missing, or damaged bolts. Contact CZM for inspection and repair or replacement options.
Seat Belt	Worn or damaged seat belt or mounting hardware.	Visible wear or damage.	Immediately replace parts that are worn or damaged.
Seat Belt	Age of seat belt.	Three years after date of installation	Replace seat belt three years after date of installation
Safety Messages	Appearance of safety message.	Damage to safety messages making them illegible.	Replace the illustrations if illegible.
Audible Warning Device(s) (if equipped)	Sound level of audible warning.	Reduced or no audible warning present.	Immediately repair or replace audible warning devices not working properly.
Camera(s) (if equipped)	Dirt or debris on camera lens.	Dirt or debris obstructing camera view.	Clean camera before operating machine.

System or Component Name	Limiting Condition	Criteria for Action	Required Action
Cab Windows (if equipped)	Dirt, debris, or damaged windows.	Dirt or debris obstructing operator visibility. Any damaged windows.	Clean windows before operating machine. Repair or replace damaged windows before operating machine.
Mirrors (if equipped)	Dirt, debris, or damaged mirror.	Dirt or debris obstructing operator visibility. Any damaged mirrors.	Clean mirrors before operating the machine. Repair or replace damaged mirrors before operating the machine.
Braking System	Inadequate braking performance.	System does not pass Braking System - Test(s) included in Maintenance Section or in the Testing and Adjusting Manual.	Contact CZM to inspect and, if necessary, repair the brake system.
Cooling System	The coolant temperature is too high.	Monitoring System displays Warning Category 3.	Stop the engine immediately. Check the coolant level and check the radiator for debris. Refer to <i>Checking the Cooling System Coolant Level*</i> (page 430). Check the fan drive belts for the water pump. Refer to <i>Inspecting/Adjusting/Replacing the Belt</i> (page 432). Make any necessary repairs.
Engine Oil System	A problem has been detected with the engine oil pressure.	Monitoring System displays Warning Category 3.	If the warning stays on during low idle, stop the engine and check the engine oil level. Perform any necessary repairs as soon as possible.
Engine System	An engine fault has been detected by the engine ECM.	Monitoring System displays Warning Category 3.	Stop the engine immediately. Contact CZM for service.
Fuel System	A problem has been detected with the fuel system.	Monitoring System displays Warning Category 3.	Stop the engine. Determine the cause of the fault and perform any necessary repairs.
Hydraulic Oil System	The hydraulic oil temperature is too high.	Monitoring System displays Warning Category 3.	Stop the engine immediately. Check the hydraulic oil level and check the hydraulic oil cooler for debris. Perform any necessary repairs as soon as possible.
Steering System	A problem has been detected with the steering system. (If equipped with steering system monitoring).	Monitoring System displays Warning Category 3.	Move the machine to a safe location and stop the engine immediately. Contact CZM to inspect and, if necessary, repair the steering system.
Overall Machine	Machine service is required.	Monitoring System displays Warning Category 3.	Stop the engine immediately. Contact CZM for service.

4.6.6. Engine Stopping*

- Lower the parallelogram and rest the tool on the ground before stopping the engine.
- Check that all the controls are in the HOLD/NEUTRAL position.
- Place the hydraulic lockout control lever in the lock position and turn the key switch to OFF.
- Stop the machine whenever it is left unattended. Bring the keys back to the designated place.
- After stopping the machine, remove the keys from the cabin, and lock the door and all the hoods with the key.
- Do not stop the engine immediately after the machine has been operated under load. Stopping the engine immediately can cause overheating and accelerated wear of engine components.
- After the machine is parked and the parking brake is engaged, allow the engine to run at low idle for 5 minutes before shutdown. Running the engine allows hot areas of the engine to cool gradually.

4.7. ASSEMBLING AND DISASSEMBLING

- Prepare an area of sufficient size and adequately equipped.
- The surface of the area must be flat and solid.
- Check that the area is free from unauthorized personnel.
- The area must be completely fenced.
- Site vehicles must not move in the area.
- Pay great attention to operations with suspended loads.
- Fall protection devices must be worn at heights above 6 ft (1.8 m).
- When disassembling or assembling connecting pins, beware of flying metal particles, which could cause injury.
- During operations, the operator and the other personnel involved must be in constant visual contact and equipped with devices that ensure direct communication in case of need (for example a walkie-talkie).
- Use a suitable lifting device for handling heavy objects (more than 25 kg). If you use a crane, it must be operated by a qualified operator.

4.8. TRANSPORTATION

To safely transport the machine is necessary:

- Know the overall dimensions of the machine and its removable components.
- Know the weight of the machine and its removable components.



NOTICE

The overall dimensions and weights change according to the machine configuration.

The transportation means must be:

- Suitable for dimensions and load capacity.
- Compliant with the laws in force in the countries to be crossed.
- In perfect conditions.

Before transportation:

- Study the path.
- Check roads, highways, bridges and tunnels for any load, width and height restrictions.
- Study the laws in force on road transport in the countries to be crossed.
- Prepare the machine in compliance with the drilling rig and base machine decals and manual procedures.
- Personnel loading, unloading, and handling the drilling rig and base machine must be skilled and experienced.

4.8.1. Loading and Unloading



WARNING

- Select a firm and level location to prevent the drilling rig from tipping over.
- Make sure the trailer is properly chocked to prevent any movement.
- Use an access ramp with enough length, strength, and width to properly support the drilling rig. The ramp grade should not exceed 15°.
- Drive slowly at the junction of the ramp and the trailer. A sudden shift may change its center of gravity and could cause a tip-over.
- Designate and use a signal person to alert the operator to any potential hazards.

Failure to follow this warning could result in death or serious injury.

- Proceed with great caution when loading the machine on the trailer, there is a risk of tip-over.
- Check that the ramps and the trailer are clean, eliminating dirt, oil, grease, and other materials that could be slippery.
- Securely tie the machine to the trailer and lock the undercarriage. An improper anchoring of the machine can cause the displacement of the load with consequent damage to people or things.
- Keep a safe distance from the roadside or ditches.
- Move the machine at a reduced speed.
- On ramps, do not operate any controls other than those for moving the undercarriage forward and backward.
- Never steer on the ramps to correct the direction of the machine. If necessary, move away from the ramps, correct the direction, then go up again.
- The machine's center of gravity will suddenly change at the junction point between the ramps and the trailer: pay attention, there is a risk of balance loss.

4.8.2. Lifting

The personnel must be well-trained and experienced before performing these operations.



WARNING

- Make sure all lifting devices are in safe operating condition and with sufficient capacity rating to safely support the intended load.
- Never lift the drilling rig with a person on it or inside the cab.
- Never allow a person to stand close to, or under, a lifted drilling rig.
- To prevent unexpected movement of the drilling rig, make sure the engine is shut down and the battery disconnect switch is set to the OFF position.
- Keep the drilling rig leveled during lifting.
- Always lift with the longitudinal centerlines of the upper structure and undercarriage parallel to each other to keep the drilling rig balanced.

Failure to follow this warning could result in death or serious injury.

4.9. MAINTENANCE



NOTICE

CZM cannot foresee all the circumstances that may involve a hazard. Therefore, the hazard alerts in this manual and on the drilling rig may not include all possible safety precautions.

4.9.1. Before Performing Maintenance



WARNING

- Before performing maintenance, read and understand the general safety warnings and specific safety messages in each maintenance procedure.
- Always move the hydraulic lockout control lever to the locked (closed) position before leaving the seat, or performing maintenance.

Failure to follow this warning could result in death or serious injury.

Read and understand the following maintenance and safety rules:

- Before performing any service, move the hydraulic lockout control lever to the locked position and turn the engine off. Perform the lockout/tagout procedure before servicing the drilling rig.
- Check that all the controls are in the HOLD/NEUTRAL position.
- Attach the "DO NOT OPERATE" tag to the controls of the machine.
- Proper maintenance is essential to ensure personnel safety and proper equipment operation.
- Wear Personal Protection Equipment (PPE) (see [Personal Protective Equipment \(PPE\) \(page 69\)](#)).
- Follow all maintenance checks and procedures. Non-compliance may result in safety hazards, improper performance or operation, or loss of warranty coverage.
- Do not allow unauthorized or non-qualified personnel to perform maintenance on the drilling rig.
- Do not start maintenance until the machine is cold.
- Perform the lockout/tagout procedure on the drilling rig in accordance with company policy and procedures.

4.9.2. During Maintenance

Read and understand the following maintenance and safety rules:

- When service is performed where it is difficult to access or is dangerous, take the necessary steps to ensure personal and job site safety.
- Do not perform any maintenance that will modify components or change original factory settings without prior authorization from CZM. This may result in safety hazards and loss of warranty for the equipment.
- Replace parts with factory original parts and only use recommended oils and greases, this will ensure proper operation of the drilling rig and the necessary safety level.
- When performing inspections or servicing when the engine must be running, additional personnel, such as a signal person, should be used to communicate between the operator and maintenance technician.
- Before disconnecting or removing components of the hydraulic system, relieve the system pressure to prevent hydraulic oil from spraying out. See [Releasing of Hydraulic Pressure from the Main Hydraulic System* \(page 450\)](#) for more information.
- When maintenance operation requires access to components that cannot be achieved from ground level, use ladders or platforms, and the required safety equipment.
- Fall protection devices must be worn at heights above 6 ft (1.8 m).
- Use approved tools and equipment suitable for the type of intervention.
- Always use tools that are in good condition.
- Always lock the doors after opening them.

- When using compressed air, use a maximum air pressure of 30 psi.
- Never put any body part in a cutting area that does not have shelters without first having firmly secured the parts.
- Do not lubricate, repair or adjust a machine in operation unless specifically required by this manual.
- Never align the holes with your fingers or hands, use a suitable tool.
- Eliminate sharp edges and burrs from repaired parts.
- Move with caution when under, in, or near the machine or its equipment.
- Do not smoke.
- Do not replace filters or components with the oil still hot or under pressure.
- Always block with external support any kinematics or part of the machine that requires interventions when it is in the raised position as required by the laws and regulations in force.

4.9.3. Moving Parts Precautions

- Never try to check or adjust the drive belts with the engine running.
- Never lubricate the machine with the engine running.
- Do not put any body parts near straps or rotating blades. Be particularly careful in the presence of rotating blades and moving fans.
- Be careful not to drop or insert tools or other objects into the fan, fan belt, or other rotating parts. They can come into contact with rotating parts and break.

4.9.4. Welding Precautions



IMPORTANT

Arc welding on machines equipped with electrical and/or electronic command, control and signaling equipment is not recommended in advance.

- Welding operations must always be conducted by a qualified welder and in a place with adequate equipment. Owners are responsible for the structural integrity of any completed repair.
- During welding operations, there is a risk of escaping gas, fire, or electric shock.
- Wear Personal Protection Equipment (PPE) (see [Personal Protective Equipment \(PPE\) \(page 69\)](#)).
- Do not carry out welding or cuts with blowtorches on tanks or pipes without having first disassembled, emptied, and washed them from oil or fuel residues.
- Do not perform arc welding or cutting with an oxyacetylene torch near flammable liquids.
- Welding activities must be appropriately marked and delimited with barriers, including movable ones, supplemented, where possible, by fireproof sheets or panels designed to avoid exposure to radiation by other personnel.
- After turning off the key switch, wait 2 minutes before disconnecting the battery. **Disconnect the negative (-) battery cable from the negative (-) post of the battery prior to welding.**
- The welding ground cable must be connected within 3.3 ft. (1 m) of the welding area. The welding cable must be connected directly to the part being welded. Do not ground through bearings or hydraulic cylinder fasteners.

4.9.5. Engine and Refueling System Precautions

- Periodically check all the components of the engine exhaust system. The exhaust gases are dangerous for the operator.
- If the original fuel tank cap is lost, replace it with an approved and homologated cap.
- Do not smoke or allow open flames or sparks nearby when refueling or handling highly flammable materials.
- Eliminate immediately, at the first sight, any fuel leaks that could cause fires.
- Do not bleed when the engine is hot as any fuel leaking onto the hot exhaust manifold would lead to a fire hazard.
- To avoid burns, pay attention to the hot parts of the engine that have just been switched off and to hot liquids in the pipes and ducts.
- Let the engine cool down before starting any intervention.
- Unscrew the radiator cap slowly to release the pressure before removing the cap.

- Add coolant with the engine stopped or at idle if hot.
- Keep the manifold and the exhaust pipe free from combustible materials.
- Equip the machine with screens and shelters when working in the presence of free combustible material in the air.
- Special starting liquids are flammable. For their use, it is necessary to strictly follow the instructions provided in the product container. Store the containers in a cool and well-ventilated place, inaccessible to unauthorized persons. Do not pierce or burn containers.
- Never use the starting liquids in the vicinity of burning or smoking materials, open flames, or sparks due to their flammability.
- Fuel leaks or spills onto hot surfaces or electrical components can cause a fire. Immediately clean all traces of fuel from leaks or spills.
- Before starting fuel delivery and during refueling, keep the nozzle in contact with the fuel inlet to reduce the likelihood of sparks caused by electrostatic electricity. Maintain contact until the fuel has stopped flowing.
- Never put gasoline or diesel fuel in an open container.
- Never use gasoline, solvents, or other flammable fluids to clean parts. Use approved commercial solvents that are non-flammable and non-toxic.
- Do not mix petrol or alcohol with diesel fuel. This mixture can cause explosions.

4.9.6. Undercarriage Precautions

- Check the tracks for correct tensioning or loosening.



WARNING

Track adjusting systems use either grease or oil under high pressure to keep the track under tension. Grease or oil under high pressure coming out of the relief valve can penetrate the body causing injury or death.

- Do not watch the relief valve to see if grease or oil is escaping. Watch the track or track adjustment cylinder to see if the track is being loosened.
- During the greasing operation, do not stand in front of the inspection panel.



- Loosen the relief valve for one turn only.
- If the track does not loosen, close the relief valve and contact CZM.
- The pins and bushings in a dry track pin joint can become very hot. It is possible to burn the fingers if there is more than brief contact with these components.

- Do not use improper tools to adjust track tension.

4.9.7. Electrical System Precautions

- Before performing any maintenance on the electrical system, turn the battery disconnect switch to the OFF position.
- Check during the day if there are any burnt lights and replace them immediately.
- Check the batteries for electrolyte leaks before starting maintenance or repairs. Eliminate leaks before proceeding.
- Search and solve the cause of the problem before replacing a fuse.
- Do not replace the fuses with others of higher amperage.

4.9.7.1. Batteries

- Always disconnect the negative (-) cable first, then disconnect the positive (+) cable.



NOTICE

Disconnecting the cables between the batteries may not completely interrupt the electrical system.

- Batteries emit flammable vapors which can explode and cause injury.
- Prevent the formation of sparks near the batteries, as they can cause the vapors to explode.
- Prevent the ends of the bridge cables from coming into contact with each other or with the machine.
- Do not smoke or use flames near the batteries.
- Incorrect procedures for connecting auxiliary cables can cause an explosion with the possibility of personal injury.
- Always connect the positive of the exhausted battery (+) with the positive (+) of the new battery, and the negative (-) with the negative (-).
- Perform the bridge only with an energy source having the same voltage as the stationary machine.
- Do not short-circuit the terminals.
- Batteries contain sulfuric acid. Protect your eyes when working near batteries to avoid possible splashing of the acid solution. If the acid comes into contact with the skin, eyes, or clothes, rinse immediately with water for a minimum of 15 minutes. Seek immediate medical attention.
- Leave the battery compartment door open while charging to improve ventilation.
- Never check the battery charge by placing a metal object across the terminal posts. Use a voltmeter to check the battery charge.
- Do not charge the batteries indoors. Provide adequate ventilation to prevent an accidental explosion due to the accumulation of explosive gases emitted during the charging phase.
- Make sure any tools or other metal objects are not in contact with the battery cables. Do not leave tools scattered around the battery.
- Securely tighten the battery cable clamps.

4.9.7.2. Electrical System Cleaning

- Clean the electrical system using approved electrical cleaners. Contact CZM product support for additional information on approved products.
- Never use high-pressure water, steam, or caustic cleaners to clean the electrical system. These could damage system components and/or cause intermittent system failures.

4.9.8. Hydraulic System Precautions

- Before carrying out any work on the hydraulic circuit, stop the engine and make sure that the pressure has been released throughout the system before removing protections and covers or disconnecting components.
- When pressure measurements are to be made, use a pressure gauge suitable for the expected values.
- Following a maintenance operation that could cause air to enter the hydraulic system (replacement of a pipe, a gasket, etc.), it is necessary to carry out at least two complete opening and closing operations of the cylinders involved to bleed any air bubbles from the hydraulic system. These operations must be carried out in safety, respecting the dangerous areas.

4.9.9. Air Conditioning System Precautions

- Never open the air conditioning system by yourself as it contains gases that must not be discharged into the atmosphere. Contact authorized workshops equipped with special equipment for plant maintenance.
- The operator must not perform any intervention on the air conditioning system. There is a risk of severe freezing or other injuries due to refrigerant leaking.
- Do not carry out welding work on or near parts of the system, even after the refrigerant has been drained. There is a risk of explosion and poisoning.

- Do not use jets of steam to clean the system.

4.9.10. Cleaning the Drilling Rig

- Always use hot water and a mild, nonflammable, grease-cutting soap or cleaning solution to clean the drilling rig.
- Never use flammable agents.
- When pressurized air and/or pressurized water is used for cleaning, wear protective clothing, protective shoes, and eye protection. Eye protection includes goggles or a protective face shield.
- The maximum air pressure for cleaning purposes must be reduced to 205 kPa (30 psi) when the nozzle is deadheaded and the nozzle is used with an effective chip deflector and personal protective equipment.
- The maximum water pressure for cleaning purposes must be below 275 kPa (40 psi).

4.10. ENVIRONMENTAL PROTECTION



ENVIRONMENTAL NOTICE

Improper waste disposal can harm the environment.

Obey all local regulations for the decommissioning and disposal of materials.

- Be careful to contain fluid spills during inspection, maintenance, tests, adjustments, and repairs of the machine
- Prepare suitable containers when opening a component or disassembling elements containing fluids.
- Dispose of used fluids in compliance with the laws and regulations in force.
- If there is no specific legislation, inquire with the suppliers of lubricants, fuels, antifreeze, and cleaning solvents regarding the effect of these products on humans and nature and on how to store, use and dispose of them.
- Avoid refueling with unsuitable cans or pressurized delivery systems, which could cause fuel losses.
- Modern lubricating oils contain additives. Do not burn contaminated fuel and/or waste oils in normal heating systems.
- Avoid spilling when coolant, engine, and gearbox lubricating oils, hydraulic oil, etc. are drained from the machine.
- Never mix discharged brake oil or fuel with lubricants. Store them safely until they can be disposed of in a manner that complies with the regulations of the country where the machine is used.
- Modern cooling mixtures (antifreeze to other additives) must be replaced every two years. Do not disperse in the ground. Collect them in suitable containers and disposed of them safely.
- To protect the environment, liquid refrigerant air conditioning systems must be properly emptied and refilled using equipment that prevents refrigerant gases from escaping into the atmosphere. Applicable laws and regulations require the recovery and recycling of refrigerants.

This page is intentionally left blank.

5. TECHNICAL SPECIFICATIONS

5.1. TECHNICAL DATA

5.1.1. Kelly Bar Standard Mast Application

Drilling Depth (standard - 4 elements; interlock kelly bar)	120 ft (37 m)
Drilling Depth (3 elements; interlock kelly bar)	90 ft (27 m)
Drilling Depth (5 elements; interlock kelly bar)	150 ft (46 m)
Drilling Depth (6 elements; friction kelly bar)	180 ft (55 m)
Drilling Diameter with Lower Mast (max)	5 ft (1.500 mm)
Drilling Diameter without Lower Mast (max)	8 ft (2.440 mm)

NOTE: Other kelly bar options are available upon request.

5.1.2. Kelly Bar Short Mast Application

Drilling Depth (standard - 5 elements; interlock kelly bar)	55 ft (16,7 m)
Drilling Depth (6 elements; friction kelly bar)	65 ft (20 m)
Drilling Diameter with Lower Mast (max)	5 ft (1.500 mm)
Drilling Diameter without Lower Mast (max)	8 ft (2.440 mm)

NOTE: Other kelly bar options are available upon request.

5.1.3. Crowd System

Cylinder Stroke - Standard Mast	11 ft (3.350 mm)
Cylinder Stroke - Short Mast	9 ft (2.740 mm)
Cylinder Push Force	43,000 lbf (19.500 kgf)
Cylinder Push Speed	56 ft/min (17 m/min)
Cylinder Pull Force	53,000 lbf (24.000 kgf)
Cylinder Pull Speed	51 ft/min (16 m/min)

5.1.4. Rotary Head–Standard

RT460–12

Maximum Torque (nominal)	88,000 lbf.ft (12.000 kgf.m)
Working Speed of Rotation	9-28 rpm
Spin-Off Rotation	70-100 rpm

5.1.4.1. Detailed Info

		Maximum Nominal Torque	Maximum Speed
Drilling	1st Gear	88,060 lbf.ft (12.175 kgf.m)	16 rpm
	2nd Gear	69,640 lbf.ft (9.630 kgf.m)	23 rpm
	3rd Gear	55,700 lbf.ft (7.700 kgf.m)	28 rpm
Spin-Off	3rd Gear	-	100 rpm

5.1.4.2. Torque Diagram

Figure 71.

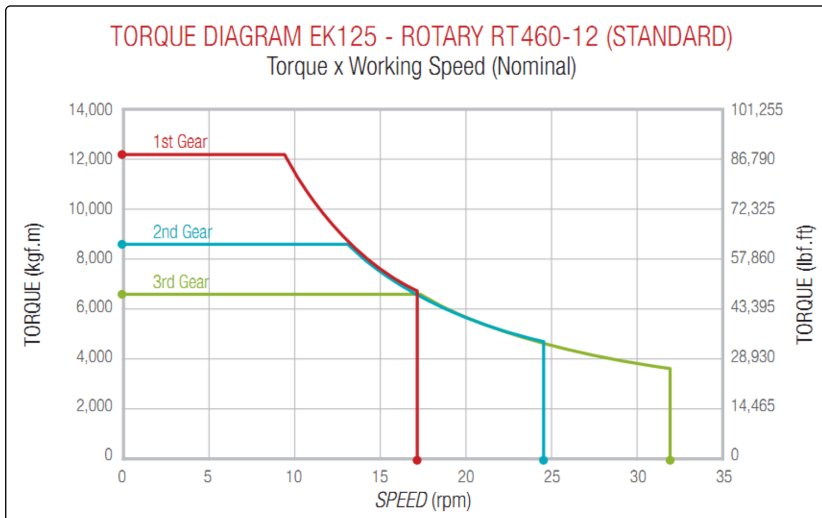

000201 Torque Diagram-Rotary

5.1.4.3. Spin-Off Diagram

Figure 72.

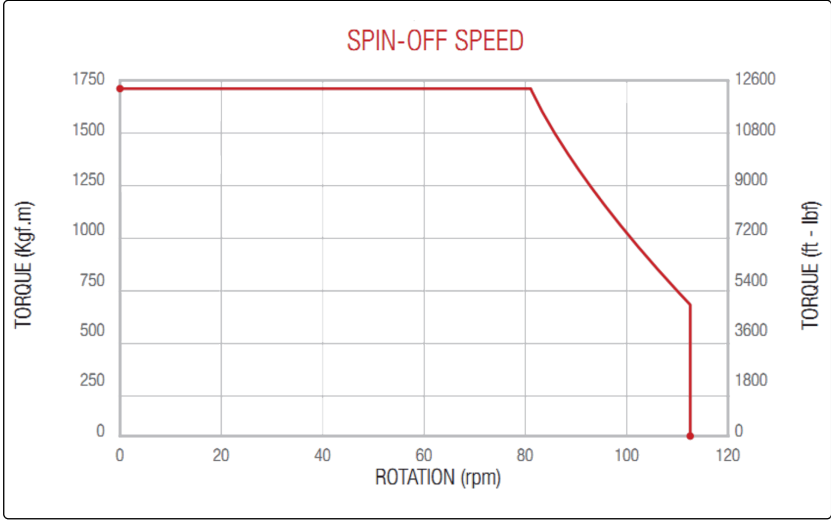

0000203 Spin-Off Diagram-Rotary

5.1.5. Rotary Head–Optional

RT460-14

Maximum Torque (nominal)	101,700 lbf.ft (14.060 kgf.m)
Working Speed of Rotation	8-24 rpm
Spin-Off Rotation	70-100 rpm

5.1.5.1. Detailed Info

		Maximum Nominal Torque	Maximum Speed
Drilling	1st Gear	101,700 lbf.ft (14.060 kgf.m)	14 rpm
	2nd Gear	75,060 lbf.ft (10.380 kgf.m)	20 rpm
	3rd Gear	60,045 lbf.ft (8.300 kgf.m)	24 rpm
Spin-Off	3rd Gear	-	100 rpm

5.1.5.2. Torque Diagram

Figure 73.

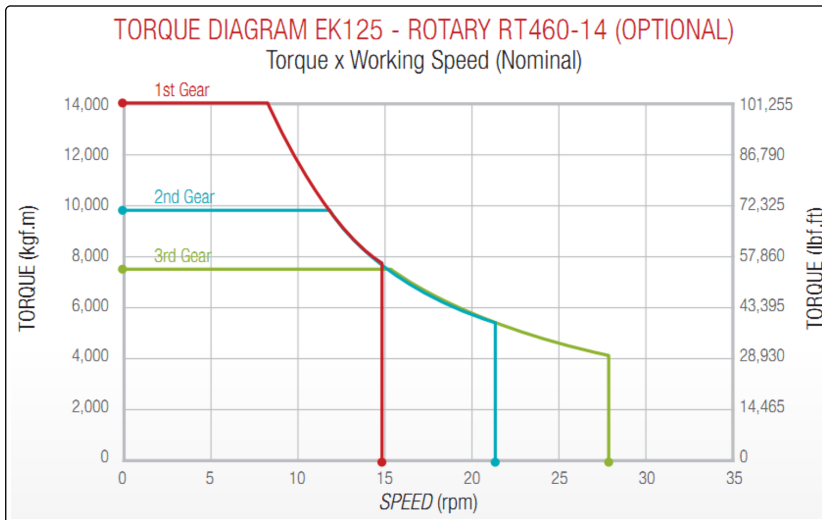

108600017_0000202 Torque Diagram-Rotary RT460-14

5.1.5.3. Spin-Off Diagram

Figure 74.

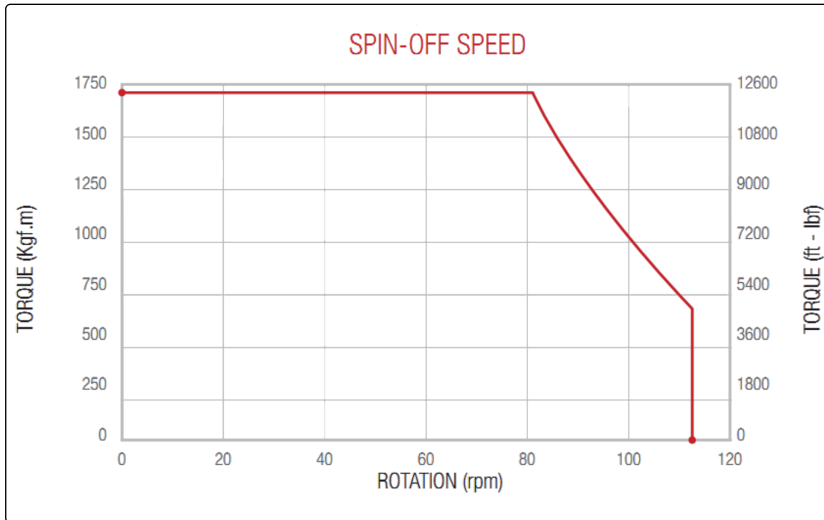

108600017_0000203 Spin-Off Diagram-Rotary RT460-12-14

5.1.6. Mast Inclination

Backward	15°
Forward	9°
Sideways	9° / 9°

5.1.7. Main Winch

Maximum Pull-force - 1st Layer (effective)	41,000 lbf (18.600 kgf)
Maximum Pull-force - 1st Layer - 2nd Speed (effective)	33,600 lbf (15.300 kgf)
Line speed - 1st Layer	200 ft/min (60 m/min)
Maximum Line Speed - 1st Layer - 2nd Speed	245 ft/min (75 m/min)
Rope Diameter	0.94 in (24 mm)
Drum Diameter - 1st Layer	18.5 in (473 mm)

5.1.7.1. Detailed Info

Nominal Line Pull	1 st Layer		
Effective Maximum Line Pull (1st Gear)	1 st Layer		40,500 lbf (18.400 kgf)
	2 nd Layer		37,370 lbf (16.950 kgf)
	3 rd Layer		34,700 lbf (15.730kgf)
Rope Speed	1 st Layer	1st Gear	200 ft/min (60 m/min)
		2nd Gear	240 ft/min (74 m/min)
	2 nd Layer	1st Gear	215 ft/min (65 m/min)
		2nd Gear	264 ft/min (80 m/min)
	3 rd Layer	1st Gear	230 ft/min (70 m/min)
		2nd Gear	284 ft/min (87 m/min)
Rope	Diameter		0.94 in (24 mm)
	Minimum Breaking Force		56.80 Tf (557 kN)
	Specifications		Rotation Resistance, Rope Grade 2160
	Recommended		Bridon Endurance Dyform 34LR - 2160

5.1.8. Auxiliary Winch

Maximum Pull-force - 1st Layer (effective)	22,000 lbf (10.000 kgf)
Line speed - 1st Layer	180 ft/min (55 m/min)
Rope Diameter	3/4 in (19 mm)
Drum Diameter - 1st Layer	16.5 in (420 mm)

5.1.8.1. Detailed Info

Effective Line Pull	1 st Layer	22,000 lbf (10.000 kgf)
	2 nd Layer	22,000 lbf (10.000 kgf)
Rope Speed	1 st Layer	64 ft/min (20 m/min)
	2 nd Layer	70 ft/min (21 m/min)
Rope	Diameter	3/4 in (19 mm)
	Minimum Breaking Force	55,000 lbf (25.000 kgf)
	Specifications	6x36 IWRC EIPS w/BLK-10 Hook on One End, And #10 Weight on Wire. X 230 ft. Length

5.1.9. Diesel Engine

Manufacturer	CATERPILLAR® ^a .
Model	CAT® C7.1 ACERT™
Net Power	172 hp (128 kW)
Displacement	433 in ³ (7.1 L)
Fuel Tank Capacity	86 gal (345 L)
Exhaust Emission Standard	EPA Tier 4 (Final)

^aCAT, CATERPILLAR, their respective logos, ACERT, SoOoS, "Caterpillar Yellow" and the "Power Edge" trade dress, as well as corporate and product identity used herein, are trademarks of Caterpillar and may not be used without permission.

5.1.10. Counterweight

Weight of CAT Counterweight (Main)	11,880 lbs (5.400 kg)
Weight of CZM Counterweight (Additional)	1,300 lbs (600 kg)

5.1.11. Hydraulic System

CAT323

Hydraulic Pressure	5,076 psi (350 bar)
Flow Rate (main circuit)	2x49 gal/min (2x185 L/min)
Pilot Circuit Pressure	569 psi (40 bar)
Pilot Circuit Flow	6.4 gal/min (24,3 L/min)
Hydraulic Oil Tank Capacity	37.8 gal (143 L)

5.1.12. Undercarriage

Track Length	15 ft 4 in (4.650 mm)
Length to Center of Rollers	12 ft 7 in (3.830 mm)
Transport Position Width (retracted)	8 ft 4 in (2.540 mm)
Working Position Width (extended)	12 ft 1 in (3.675 mm)
Shoe Width	23.6 in (600 mm)
Maximum Drawbar Pull	46,085 lbf (20.500 kgf)
Maximum Travel Speed	1.93 mph (3,1 km/h)
Track Weight	22,660 lb (10.300 kg)

5.1.13. Transportation

	Standard Mast Version	Short Mast Version
Transport Height	11 ft 6 in (3.510 mm)	10 ft 9 in (3.270 mm)
Transport Length	50 ft 10 in (15.500 mm)	34 ft (10.370 mm)
Transport Width	9 ft (2.759 mm)	9 ft (2.759 mm)
Transport Weight (standard Kelly 4/120 ft)	82,500 lb (37.500 kg)	-
Transport Weight (Kelly 3/80 ft)	79,500 lb (36.150 kg)	-
Transport Weight (Kelly 5/155 ft)	85,000 lb (38.600 kg)	-
Transport Weight (Kelly 5/55 ft)	-	74,500 lb (33.850 kg)

5.2. DIMENSIONS

5.2.1. Standard Mast Version

5.2.1.1. Overall Dimensions

Figure 75.

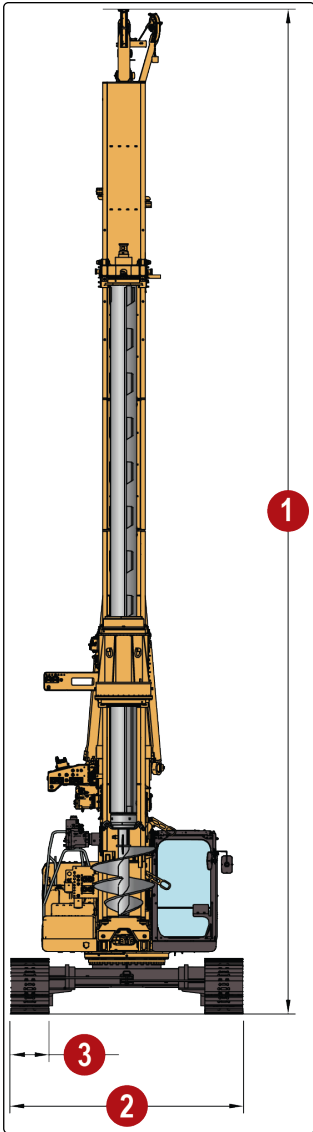

0000214 Standard Mast Overall Dimensions

1	52 ft (15.815 mm)
2	12 ft 1 in (3.675 mm)
3	24 in (600 mm)

5.2.1.2. Dimensions With Small Auger

Figure 76.

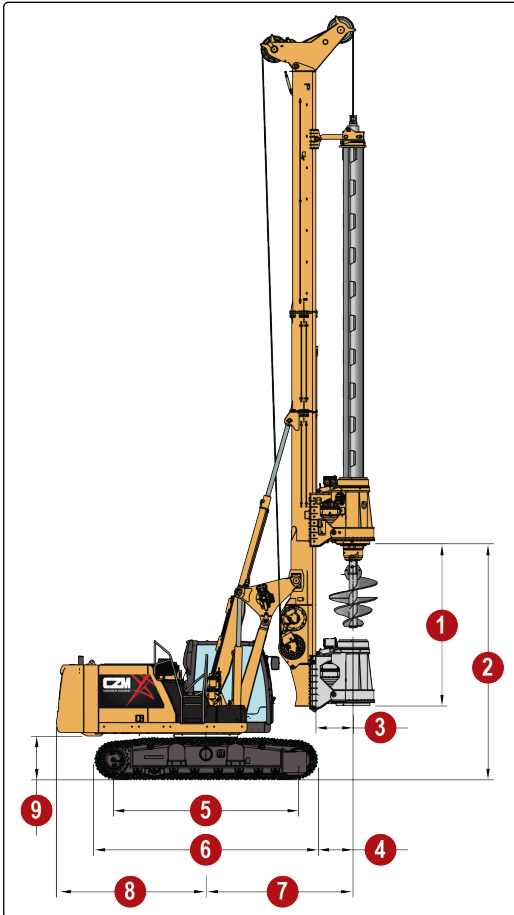

000216 Standard Mast With Small Auger

1	11 ft (3.353 mm)
2	16 ft (4.875 mm)
3	2 ft 6 in (770 mm)
4	2.4 - 5.17 ft (715 mm - 1.575 mm)
5	12 ft 7 in (3.830 mm)
6	15 ft 4 in (4.650 mm)
7	10 - 12 ft 10 in (3.040 - 3.900 mm)
8	10 ft 2 in (3.095 mm)
9	3 ft (900 mm)

5.2.1.3. Dimensions With Large Auger

Figure 77.

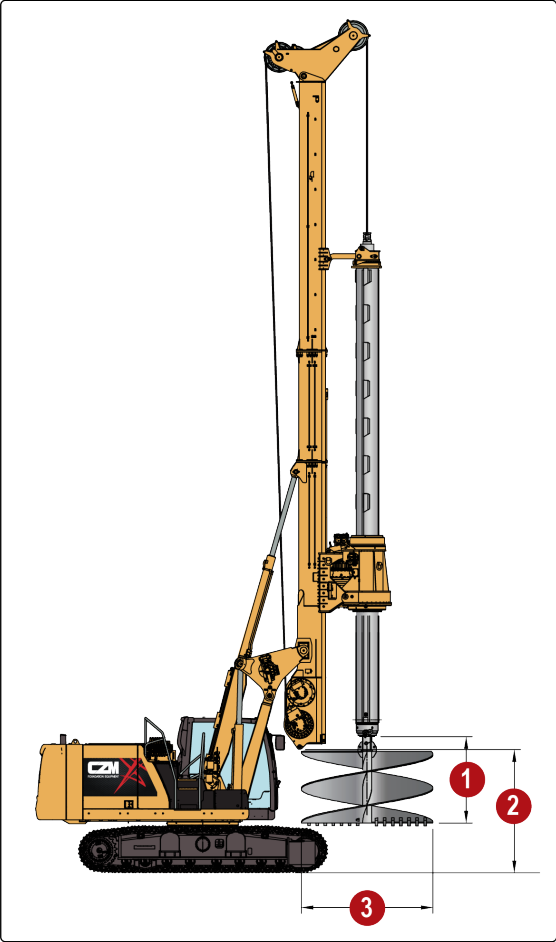

0000215 Standard Mast With Large Auger

1	5 ft 3 in (1.600 mm)
2	7 ft 6 in (2.285 mm)
3	8 ft (2.440 mm)

5.2.1.4. Transport Dimensions

Figure 78.

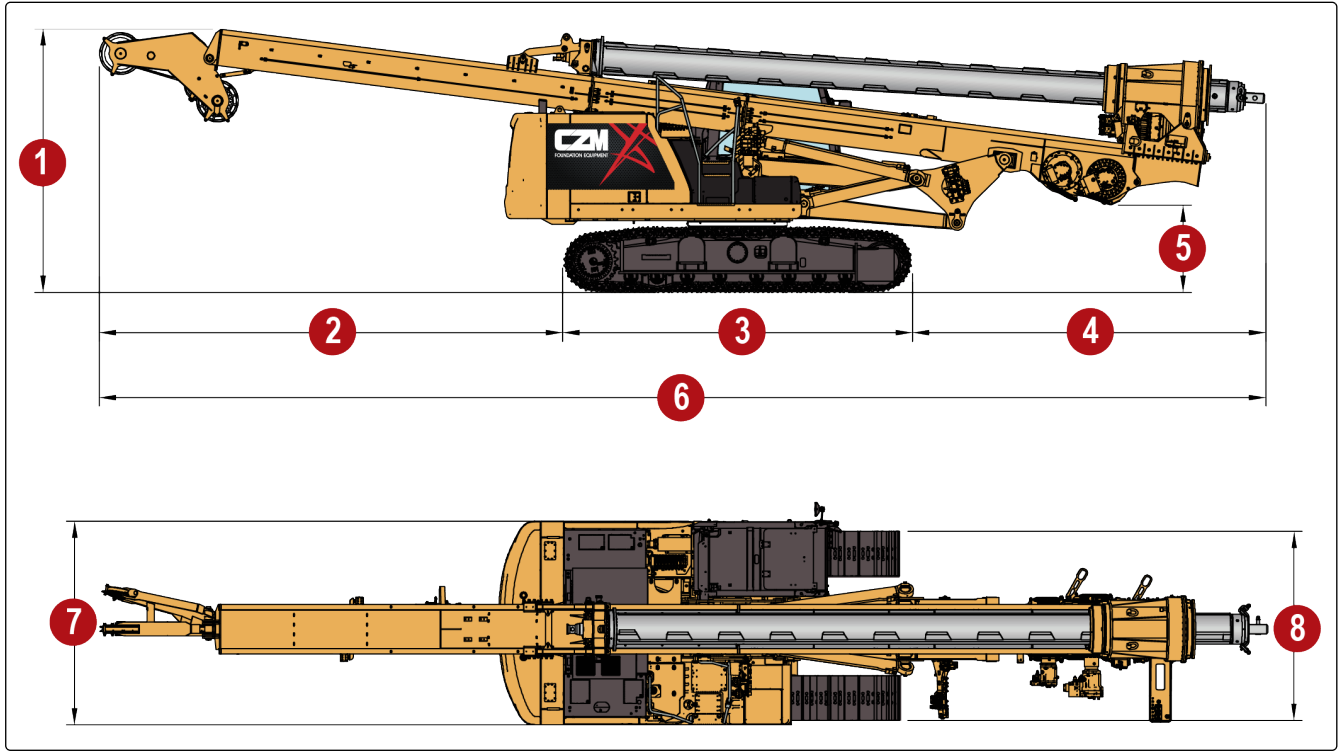

0000217 Standard Mast Transport

1	11 ft 6 in (3.510 mm)
2	20 ft 2 in (6.155 mm)
3	15 ft 4 in (4.650 mm)
4	15 ft 5 in (4.695 mm)
5	3 ft 10 in (1.165 mm)
6	50 ft 10 in (15.500 mm)
7	9 ft (2.759 mm)
8	8 ft 4 in (2.550 mm)



NOTICE

Weight: 82,500 lb (37.500 kg) with standard kelly bar 4 elements/120 ft.

5.2.2. Short Mast Version

5.2.2.1. Overall Dimensions

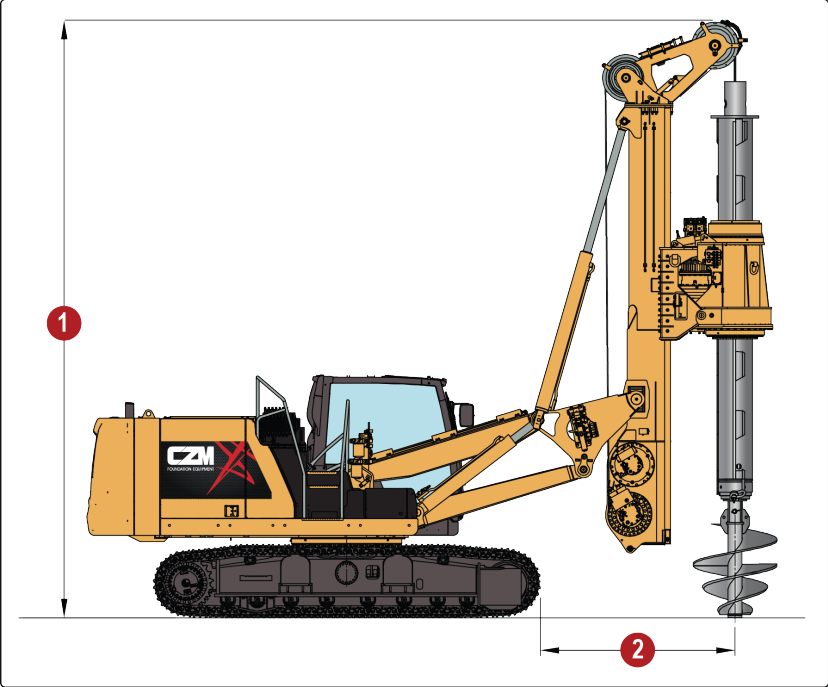
Figure 79.



000221 Short Mast Overall Dimensions

1	23 ft 4 in (7.120 mm)
2	7 ft 7 in (2.320 mm)

5.2.2.2. Dimensions With Small Auger

Figure 80.

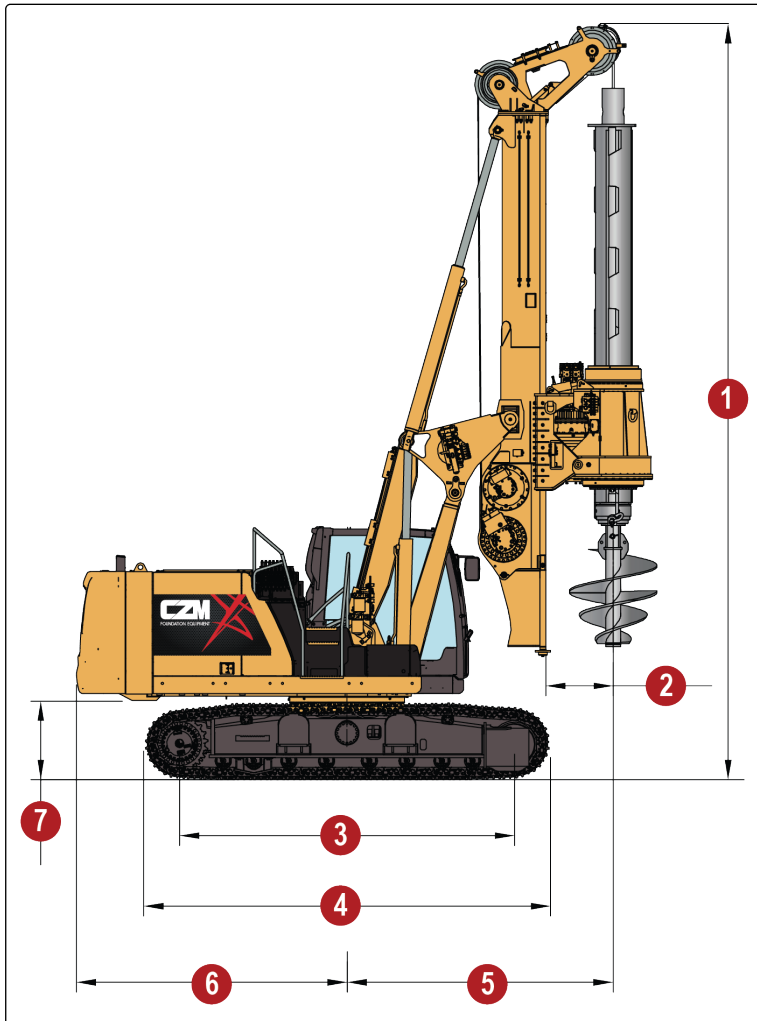

0000219 Short Mast With Small Auger

1	28 ft 5 in (8.650 mm)
2	2 ft 6 in (770 mm)
3	12 ft 7 in (3.830 mm)
4	15 ft 4 in (4.650 mm)
5	10 ft-12 ft 10 in (3.040-3.900 mm)
6	10 ft 15 in (3.095 mm)
7	3 ft (900 mm)

5.2.2.3. Dimensions With Large Auger

Figure 81.

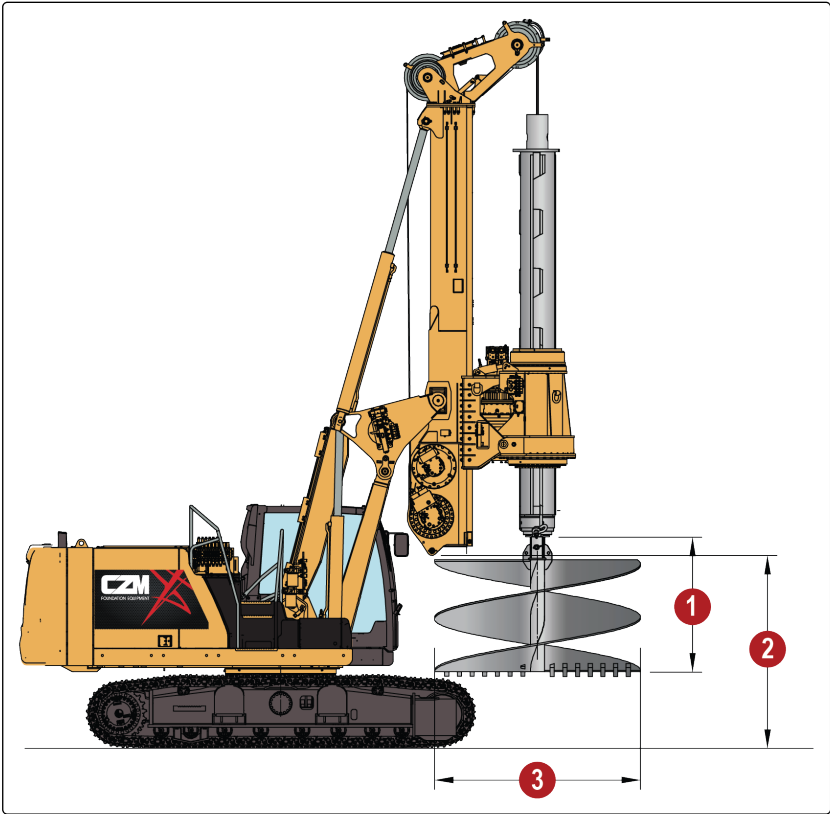

0000220 Short Mast With Large Auger

1	5 ft 3 in (1.600 mm)
2	7 ft 6 in (2.285 mm)
3	8 ft (2.440 mm)

5.2.2.4. Transport Dimensions

Figure 82.

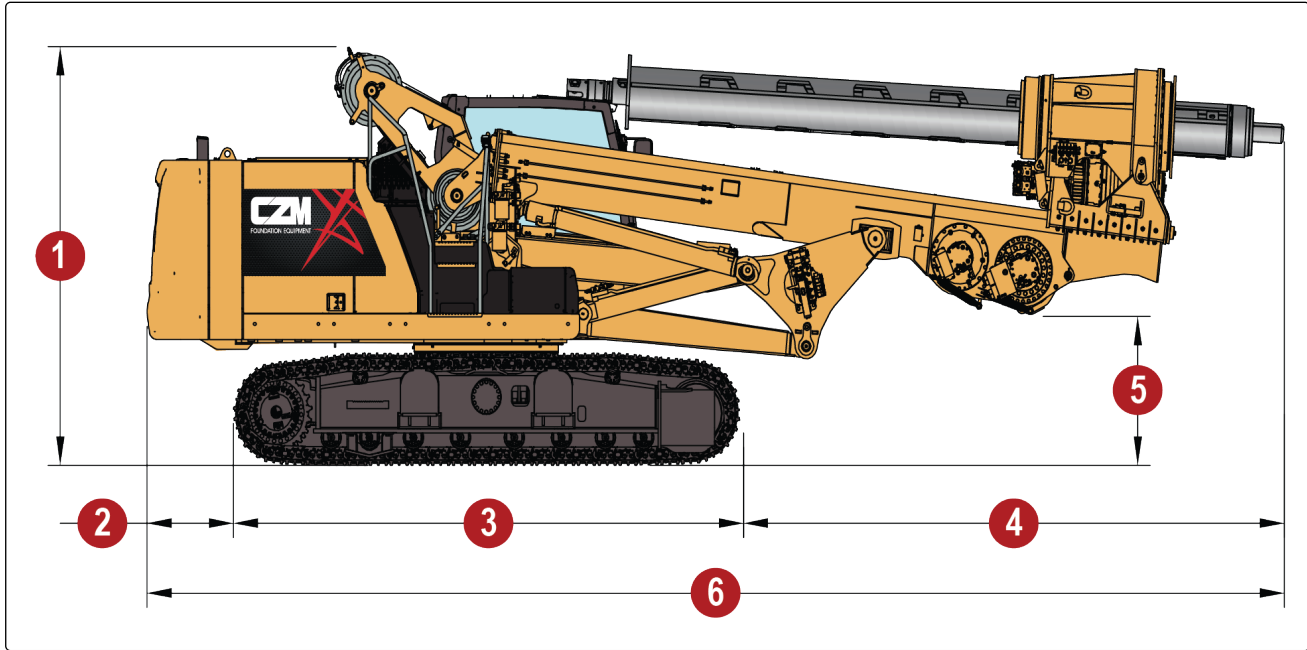

0000222 Short Mast Transport

1	10 ft 9 in (3.270 mm)
2	2 ft 7 in (790 mm)
3	15 ft 4 in (4.650 mm)
4	16 ft 2 in (4.930 mm)
5	3 ft 10 in (1.165 mm)
6	34 ft (10.370 mm)



NOTICE

Weight: 74,500 lb (33.850 kg) with standard kelly bar 5 elements/55 ft.

5.2.3. Components

5.2.3.1. Rotary

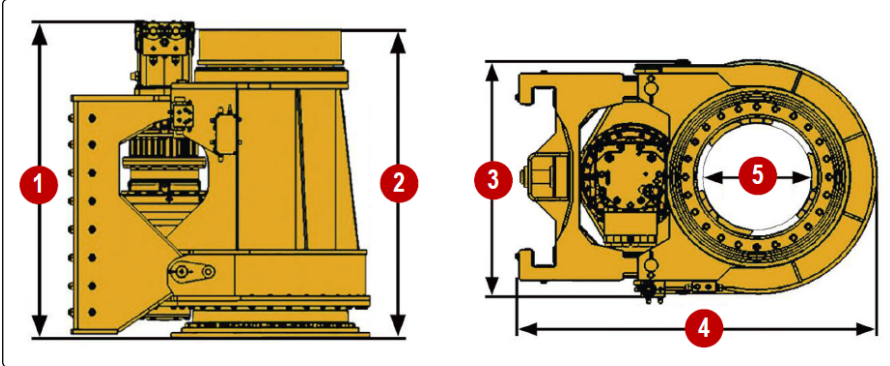
Figure 83.



0000200 Rotary Dimensions

1	Overall Height	57.3 in (1.455 mm)
2	Height	55.7 in (1.415 mm)
3	Width	35.4 in (899 mm)
4	Length	53.6 in (1.361 mm)
5	Inside Diameter (ID)	18 in (457 mm)

5.3. STABILITY AND GROUND PRESSURE

Stability is a concern of a drill rig as it has a mast to drill the required depths.

Tipping over is a hazard that can occur by exceeding the degrees of slope that the machine can safely operate while traveling, swinging, lifting loads, drilling, etc.

Tipping over can occur even by failing to set up the machine correctly, such as expanding the tracks, installing the counterweight, following the limits of weight for the auxiliary winch, tooling, etc.

A major concern is the machine-induced ground pressure (6) exceeding the resistance of the soil.

The ground pressure is a factor of the weight of the machine (4) and how it is balanced, and the induced loads, such as:

- the main winch pulling force (5)
- crowd cylinder pushing/pulling force (3)
- auxiliary winch pulling force
- wind forces (2).

A work platform (1) should be required under the machine to prevent tipping over whenever necessary.

Exceeding the ground resistance can cause the ground to fail and is the primary reason for the machine's tip-over.

Always follow the stability and ground pressure guidelines for the operation being proceed.

Figure 84.

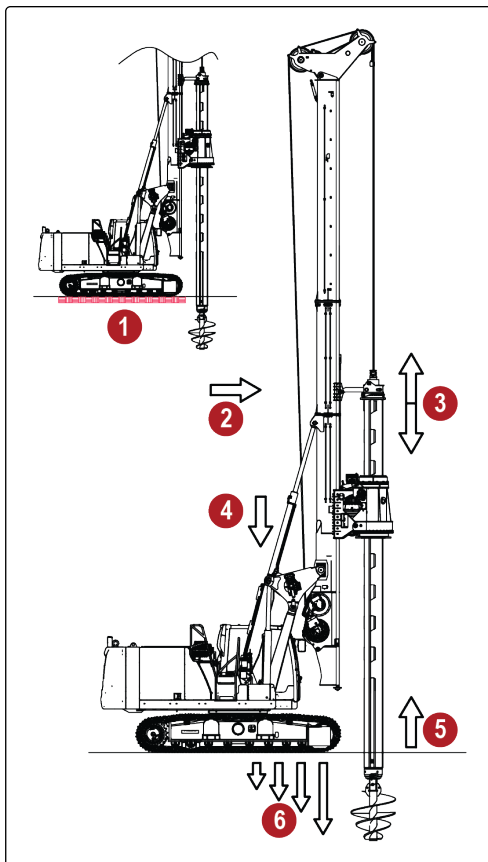

0000241 Stability and Ground Pressure

5.3.1. Standard Mast Version

5.3.1.1. Traveling - Forward Facing

Table 8. Standard Mast Traveling Stability-Forward Facing

Distance (d)	Stability Angle (a)	Ground Pressure (G.P.)	C.G. X	C.G. Y
2 ft 5 in (762 mm)	27.0°	21.9 psi (1,54 kgf/cm ²)	4 ft 5 in (1.339 mm)	8 ft 6 in (2.626 mm)
The stability angle (a) is calculated according to European Standard BS EN 16228-1:2014.				

Figure 85.

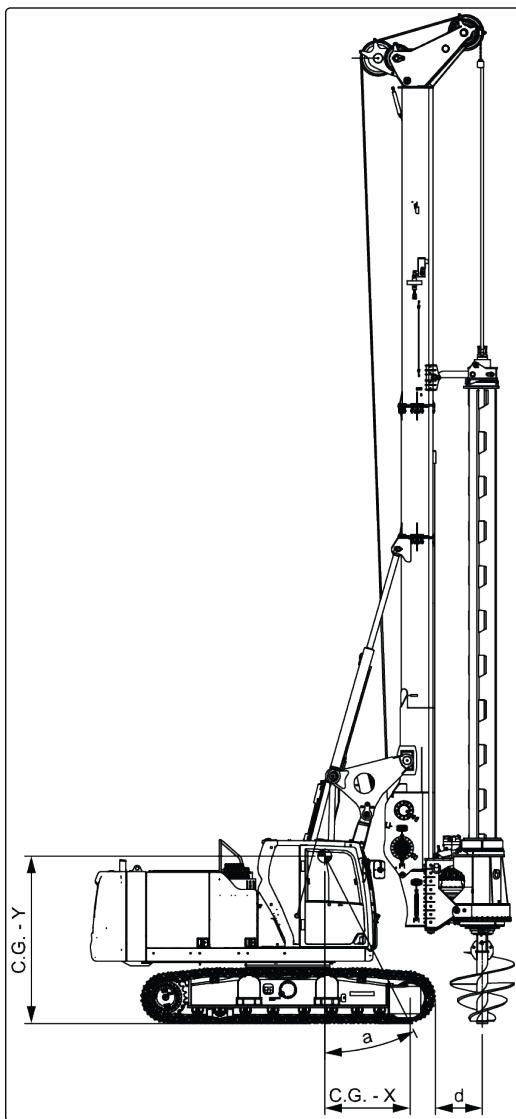

0000251 Standard Mast Traveling Stability-Forward Facing

Table 9. Standard Mast Traveling Stability-Forward Facing-Conditions

Values are valid within the following conditions:	
Mast	Upright position
Boom	All the way back
Undercarriage tracks	Spread
Counterweight	13,227 lb (6.000 kg)
Machine	On firm horizontal and even surface
Accessories (kelly bar, tooling, rotary)	Lowered as close to the ground as possible
Track shoes	23.6 in (600 mm)
Kelly bar	4 elements, 120 ft (36.576 mm) / 10,031 lb (4.550 kg)
Drilling tool	3,307 lb (1.500 kg)
Permissible wind speed	45 mph (72,4 km/h)
Slopes	Do not exceed 10 degrees

WARNING

In the case of different configurations, these values are no longer valid, and they must be recalculated. Contact CZM After Sales Department for details.
Failure to follow this warning could result in death or serious injury.

5.3.1.2. Traveling - Off the Side

Table 10. Standard Mast Traveling Stability-Off the Side

Distance (d)	Stability Angle (a)	Ground Pressure (G.P.)	C.G. X	C.G. Y
4 ft (1.225 mm)	20.6°	16.6 psi (1,17 kgf/cm ²)	3 ft 2.9 in (987 mm)	8 ft 6 in (2.626 mm)
The stability angle (a) is calculated according to European Standard BS EN 16228-1:2014.				

Figure 86.

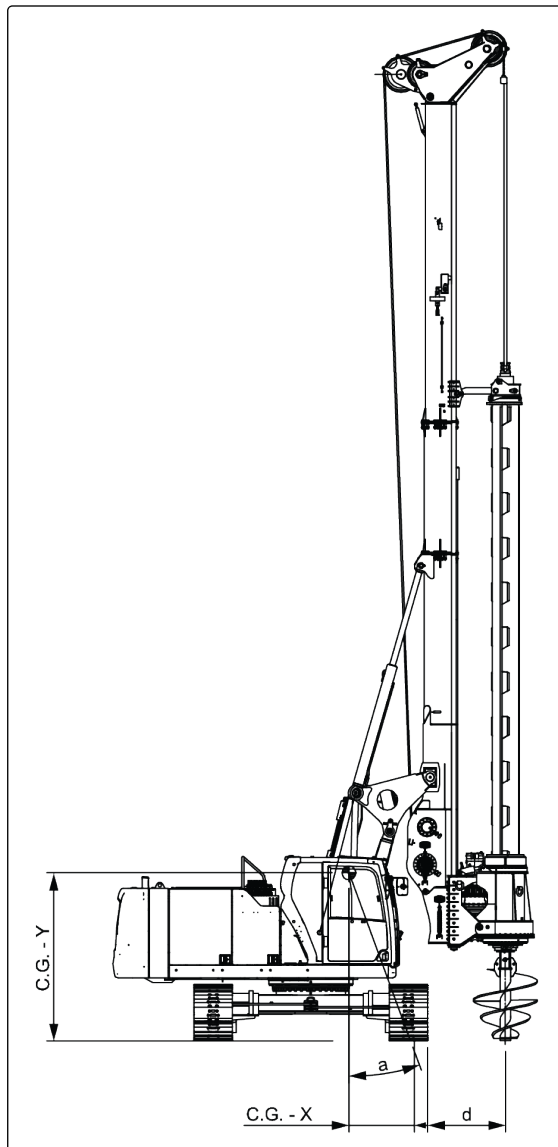

000252 Standard Mast Traveling Stability-Off the Side

Table 11. Standard Mast Traveling Stability-Off the Side-Conditions

Values are valid within the following conditions:	
Mast	Upright position
Boom	All the way back
Undercarriage tracks	Spread
Counterweight	13,227 lb (6.000 kg)
Machine	On firm horizontal and even surface
Accessories (kelly bar, tooling, rotary)	Lowered as close to the ground as possible
Track shoes	23.6 in (600 mm)
Kelly bar	4 elements, 120 ft (36.576 mm) / 10,031 lb (4.550 kg)
Drilling tool	3,307 lb (1.500 kg)
Permissible wind speed	45 mph (72,4 km/h)
Slopes	Do not exceed 5 degrees

WARNING

In the case of different configurations, these values are no longer valid, and they must be recalculated. Contact CZM After Sales Department for details.
Failure to follow this warning could result in death or serious injury.

5.3.1.3. Drilling - Forward Facing

Table 12. Standard Mast Drilling Stability-Forward Facing-Lateral View

Distance (d)	Stability Angle (a)	Ground Pressure (G.P.)	C.G. X	C.G. Y
2 ft 5 in (762 mm)	19.9°	50.8 psi (3,58 kgf/cm ²)	3 ft 3 in (989 mm)	9 ft (2.733 mm)
3 ft 11 in (1.185 mm)	13.8°	73.3 psi (5,16 kgf/cm ²)	2 ft 2 in (661 mm)	8 ft 10 in (2.687 mm)
5 ft 4 in (1.635 mm)	7.3°	131.3 psi (9,25 kgf/cm ²)	1 ft 1 in (334 mm)	8 ft 7 in (2.607 mm)

The stability angle (a) is calculated according to European Standard BS EN 16228-1:2014.

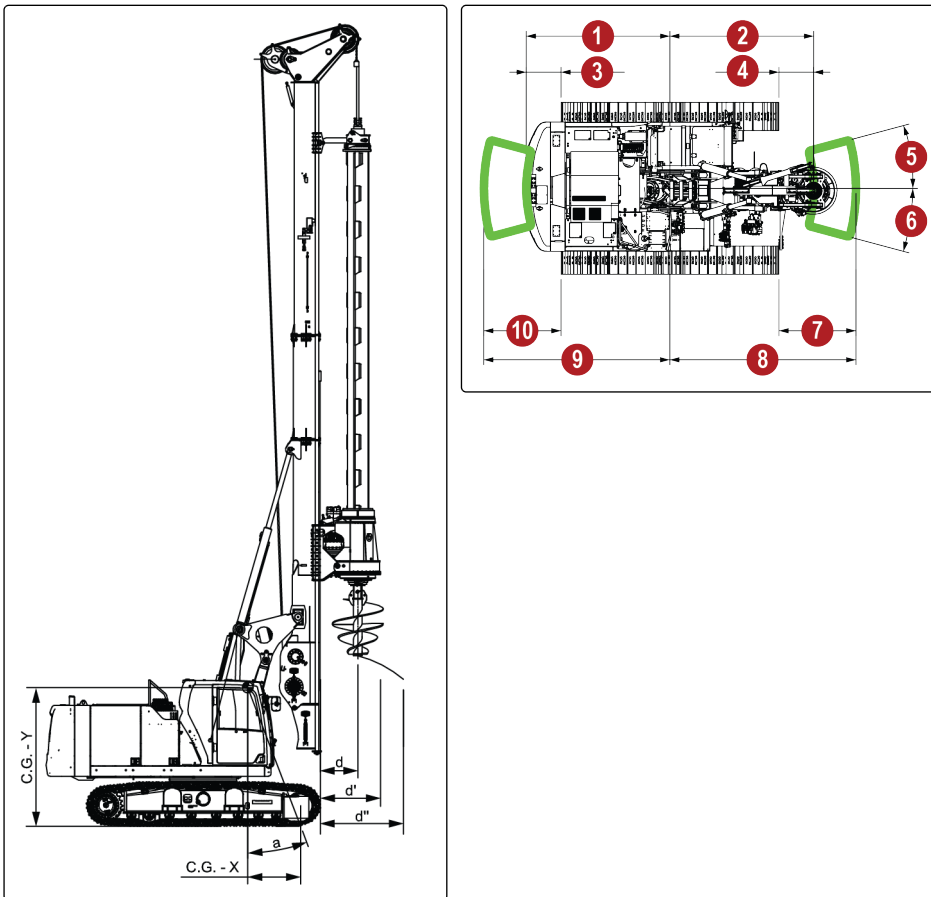

i NOTICE

- The maximum allowed main winch pull force is 41,000 lbf (18.600 kgf)
- The maximum force can be applied when the center of the tool is inside the safe zone specified below.

Table 13. Standard Mast Drilling Stability-Forward Facing-Top View

Pos.	Value
1	10 ft (3.051 mm)
2	10 ft (3.051 mm)
3	2 ft 5 in (762 mm)
4	2 ft 5 in (762 mm)
5	15°
6	15°
7	5 ft 4 in (1.635 mm)
8	12 ft 11 in (3.945 mm)
9	12 ft 11 in (3.945 mm)
10	5 ft 4 in (1.635 mm)

Table 14. Standard Mast Drilling Stability-Forward Facing-Conditions

Values are valid within the following conditions:	
Mast	Upright position
Undercarriage tracks	Spread
Counterweight	13,227 lb (6.000 kg)
Machine	On firm horizontal and even surface
Track shoes	23.6 in (600 mm)
Kelly bar	4 elements, 120 ft (36.576 mm) / 10,031 lb (4.550 kg)
Drilling tool	3,307 lb (1.500 kg)
Permissible wind speed	45 mph (72,4 km/h)

WARNING

In the case of different configurations, these values are no longer valid, and they must be recalculated. Contact CZM After Sales Department for details. Failure to follow this warning could result in death or serious injury.

5.3.1.4. Drilling - Off The Side

Table 15. Standard Mast Drilling Stability-Off The Side

Distance (d)	Stability Angle (a)	Ground Pressure (G.P.)	C.G. X	C.G. Y
4 ft (1.225 mm)	10.7°	26.7 psi (1,88 kgf/cm ²)	1 ft 7 in (518 mm)	9 ft (2.733 mm)
4 ft 6 in (1.412,5 mm)	7.9°	28.2 psi (1,99 kgf/cm ²)	1 ft 2 in (378 mm)	8 ft 9 in (2.717 mm)
5 ft 3 in (1.605 mm)	5.0°	29.6 psi (2,10 kgf/cm ²)	9.3 in (238 mm)	8 ft 8 in (2.696 mm)

The stability angle (a) is calculated according to European Standard BS EN 16228-1:2014.

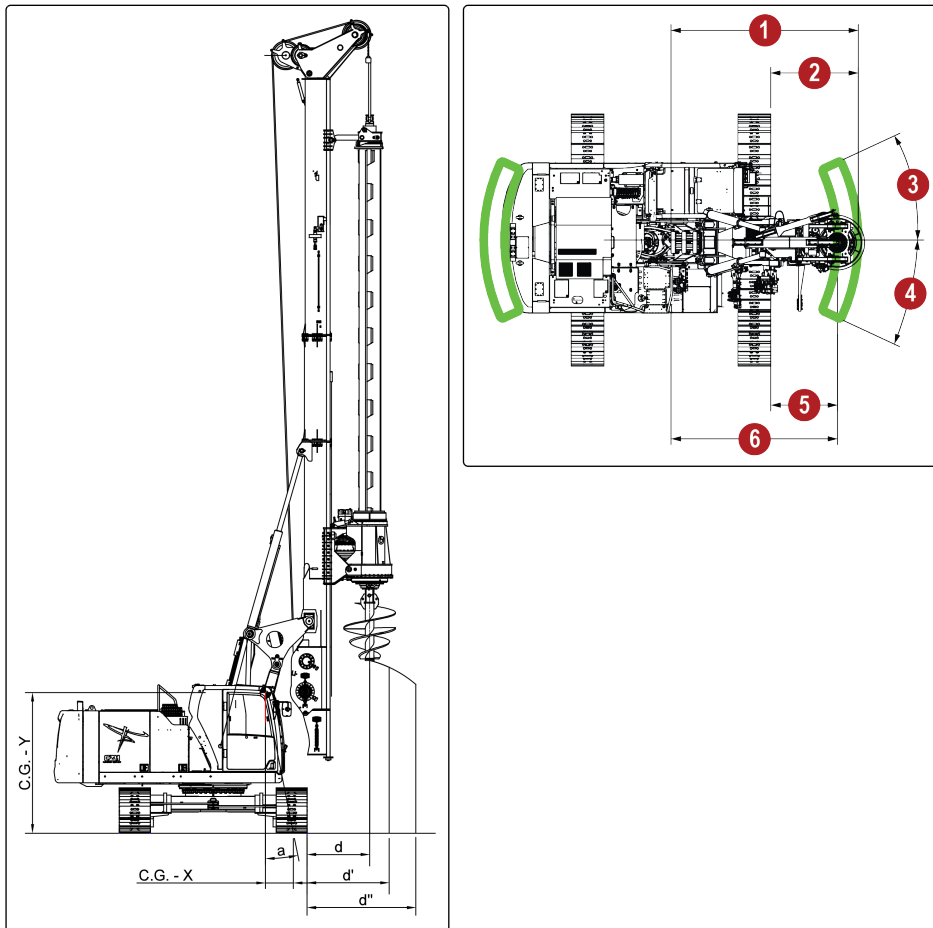

i NOTICE

- The maximum allowed main winch pull force is 41,000 lbf (18.600 kgf)
- The maximum force can be applied when the center of the tool is inside the safe zone specified above.

Table 16. Standard Mast Drilling Stability-Off The Side-Top View

Pos.	Value
1	11 ft 3 in (3.425 mm)
2	5 ft 3 in (1.600 mm)
3	25°
4	25°
5	4 ft (1.225 mm)
6	10 ft (3.046 mm)

Table 17. Standard Mast Drilling Stability-Off The Side-Conditions

Values are valid within the following conditions:	
Mast	Upright position
Undercarriage tracks	Spread
Counterweight	13,227 lb (6.000 kg)
Machine	On firm horizontal and even surface
Track shoes	23.6 in (600 mm)
Kelly bar	4 elements, 120 ft (36.576 mm) / 10,031 lb (4.550 kg)
Drilling tool	3,307 lb (1.500 kg)
Permissible wind speed	45 mph (72,4 km/h)

WARNING

In the case of different configurations, these values are no longer valid, and they must be recalculated. Contact CZM After Sales Department for details.
Failure to follow this warning could result in death or serious injury.

5.3.1.5. Auxiliary Winch - Forward Facing Tilted

Table 18. Standard Mast Auxiliary Winch Stability-Forward Facing

Distance (d)	Stability Angle (a)	Ground Pressure (G.P.)	C.G. X	C.G. Y
8 ft 1 in (2.470 mm)	12.6°	75 psi (5,28 kgf/cm ²)	1 ft 9 in (576 mm)	8 ft 5 in (2.582 mm)

The stability angle (a) is calculated according to European Standard BS EN 16228-1:2014.

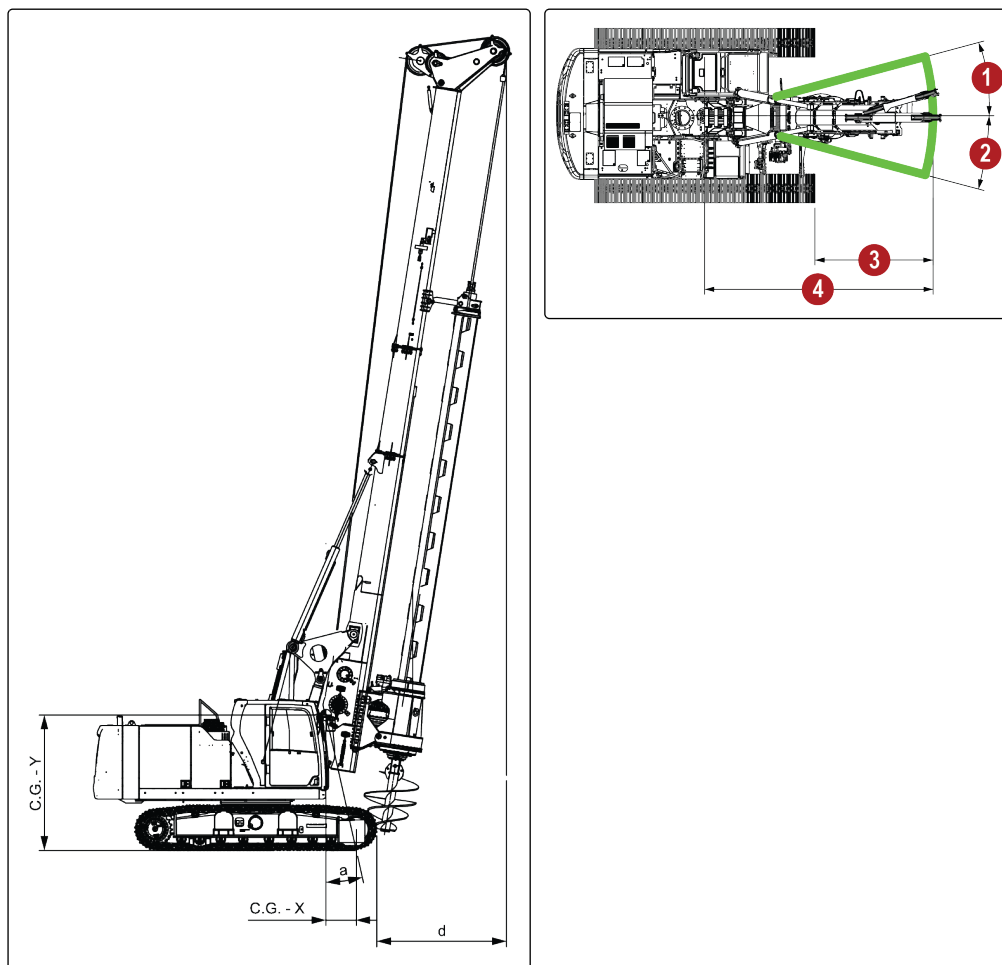

i NOTICE

- The maximum allowed pick-up weight is 22,046 lb (10.000 kg).
- The maximum force can be applied when the parallelogram is all the way back.
- The machine can only swing 15° to each side on this configuration.

Table 19. Standard Mast Auxiliary Winch Stability-Forward Facing-Top View

Pos.	Value
1	15°

Pos.	Value
2	15°
3	8 ft 1 in (2.470 mm)
4	15 ft 8 in (4.780 mm)

Table 20. Standard Mast Auxiliary Winch Stability-Forward Facing-Conditions

Values are valid within the following conditions:	
Mast	Tilted forward up to 9°
Boom	All the way back
Undercarriage tracks	Spread
Counterweight	13,227 lb (6.000 kg)
Machine	On firm horizontal and even surface
Track shoes	23.6 in (600 mm)
Accessories (kelly bar, tooling, rotary)	Lowered as close to the ground as possible
Kelly bar	4 elements, 120 ft (36.576 mm) / 10,031 lb (4.550 kg)
Drilling tool	3,307 lb (1.500 kg)
Permissible wind speed	45 mph (72,4 km/h)

WARNING

In the case of different configurations, these values are no longer valid, and they must be recalculated. Contact CZM After Sales Department for details.

Failure to follow this warning could result in death or serious injury.

5.3.1.6. Auxiliary Winch - Off The Side Tilted

Table 21. Standard Mast Auxiliary Winch Stability-Off The Side Tilted

Distance (d)	Stability Angle (a)	Ground Pressure (G.P.)	C.G. X	C.G. Y
9 ft 8 in (2.950 mm)	10°	24 psi (1,69 kgf/cm ²)	1 ft 5 in (455 mm)	8 ft 47 in (2.583 mm)
The stability angle (a) is calculated according to European Standard BS EN 16228-1:2014.				

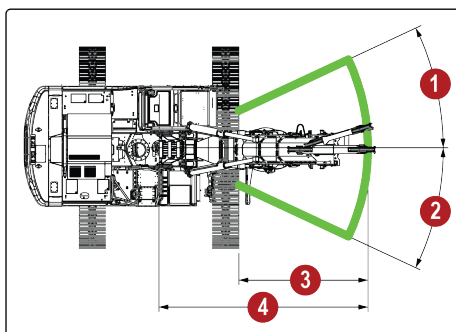
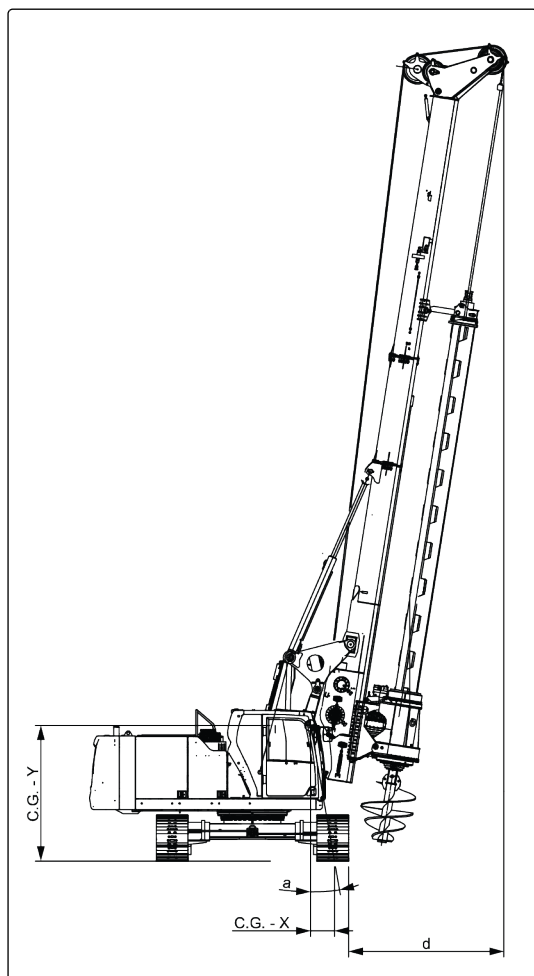

NOTICE

- The maximum allowed pick-up weight is 13,227 lb (6.000 kg).
- The maximum force can be applied when the parallelogram is all the way back.
- The machine can only swing 25° to each side on this configuration.

Table 22. Standard Mast Auxiliary Winch Stability-Off The Side Tilted-Top View

Pos.	Value
1	25°

Pos.	Value
2	25°
3	9 ft 8 in (2.950 mm)
4	15 ft 8 in (4.780 mm)

Table 23. Standard Mast Auxiliary Winch Stability-Off The Side Tilted-Conditions

Values are valid within the following conditions:	
Mast	Tilted forward up to 9°
Boom	All the way back
Undercarriage tracks	Spread
Counterweight	13,227 lb (6.000 kg)
Machine	On firm horizontal and even surface
Track shoes	23.6 in (600 mm)
Accessories (kelly bar, tooling, rotary)	Lowered as close to the ground as possible
Kelly bar	4 elements, 120 ft (36.576 mm) / 10,031 lb (4.550 kg)
Drilling tool	3,307 lb (1.500 kg)
Permissible wind speed	45 mph (72,4 km/h)

WARNING

In the case of different configurations, these values are no longer valid, and they must be recalculated. Contact CZM After Sales Department for details.
Failure to follow this warning could result in death or serious injury.

5.3.2. Short Mast Version

5.3.2.1. Traveling - Forward Facing

Table 24. Short Mast Traveling Stability-Forward Facing

Distance (d)	Stability Angle (a)	Ground Pressure (G.P.)	C.G. X	C.G. Y
2 ft 5 in (735 mm)	39.0°	13.74 psi (0,97 kgf/cm ²)	6 ft 9 in (2.059 mm)	8 ft 3.9 in (2.539 mm)
The stability angle (a) is calculated according to European Standard BS EN 16228-1:2014.				

Figure 87.

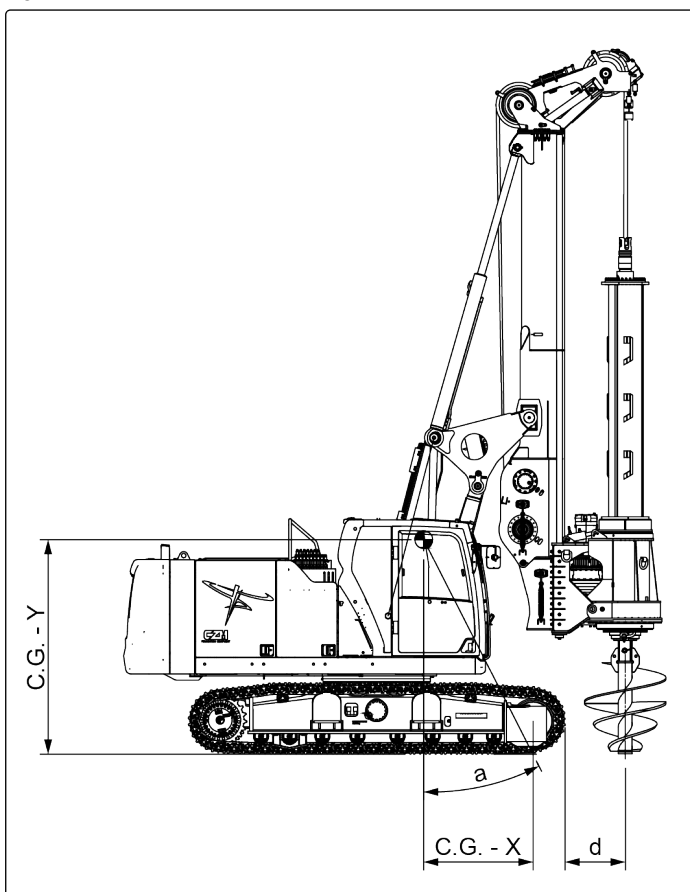

0000316 Short Mast Traveling Stability-Forward Facing

Table 25. Short Mast Traveling Stability-Forward Facing-Conditions

Values are valid within the following conditions:	
Mast	Upright position
Boom	All the way back
Undercarriage tracks	Spread
Counterweight	13,227 lb (6.000 kg)

Values are valid within the following conditions:	
Machine	On firm horizontal and even surface
Accessories (kelly bar, tooling, rotary)	Lowered as close to the ground as possible
Track shoes	23.6 in (600 mm)
Kelly bar	5 elements, 55 ft (16.764 mm) / 5,511 lb (2.500 kg)
Drilling tool	3,307 lb (1.500 kg)
Permissible wind speed	45 mph (72,4 km/h)
Slopes	Do not exceed 10 degrees

WARNING

In the case of different configurations, these values are no longer valid, and they must be recalculated. Contact CZM After Sales Department for details.
Failure to follow this warning could result in death or serious injury.

5.3.2.2. Traveling - Off the Side

Table 26. Short Mast Traveling Stability-Off the Side

Distance (d)	Stability Angle (a)	Ground Pressure (G.P.)	C.G. X	C.G. Y
4 ft (1.220 mm)	33.1°	10.45 psi (0,74 kgf/cm ²)	5 ft 5.15 in (1.655 mm)	8 ft 3.9 in (2.539 mm)
The stability angle (a) is calculated according to European Standard BS EN 16228-1:2014.				

Figure 88.

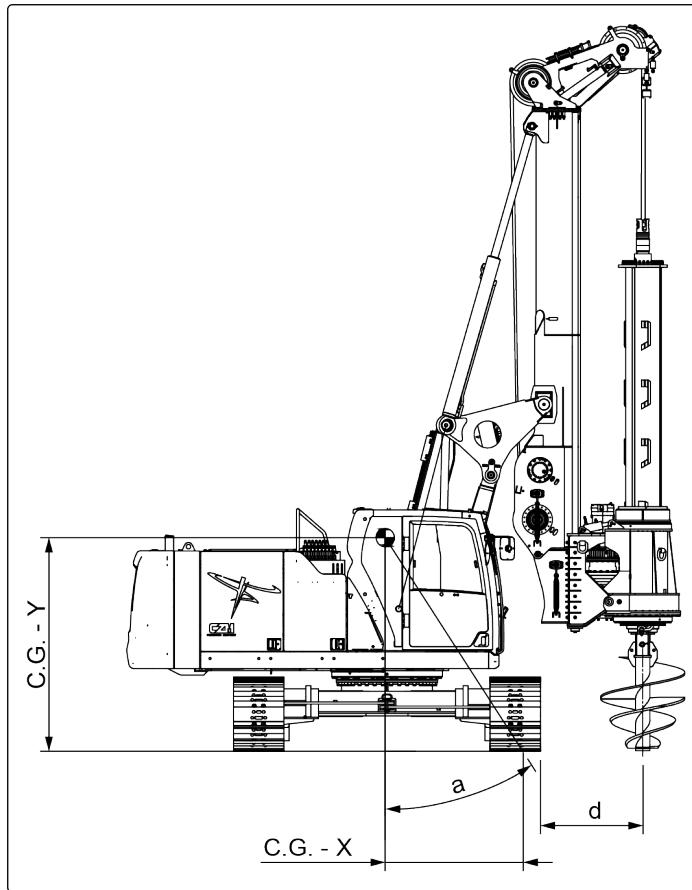

000317 Short Mast Traveling Stability-Off the Side

Table 27. Short Mast Traveling Stability-Off the Side-Conditions

Values are valid within the following conditions:	
Mast	Upright position
Boom	All the way back
Undercarriage tracks	Spread
Counterweight	13,227 lb (6.000 kg)
Machine	On firm horizontal and even surface

Values are valid within the following conditions:	
Accessories (kelly bar, tooling, rotary)	Lowered as close to the ground as possible
Track shoes	23.6 in (600 mm)
Kelly bar	5 elements, 55 ft (16.764 mm) / 5,511 lb (2.500 kg)
Drilling tool	3,307 lb (1.500 kg)
Permissible wind speed	45 mph (72,4 km/h)
Slopes	Do not exceed 5 degrees

WARNING

In the case of different configurations, these values are no longer valid, and they must be recalculated. Contact CZM After Sales Department for details.
Failure to follow this warning could result in death or serious injury.

5.3.2.3. Drilling - Forward Facing

Table 28. Short Mast Drilling Stability-Forward Facing-Lateral View

Distance (d)	Stability Angle (a)	Ground Pressure (G.P.)	C.G. X	C.G. Y
2 ft 5 in (735 mm)	32.9°	35.8 psi (2,52 kgf/cm ²)	5 ft 1.4 in (1.560 mm)	7 ft 11 in (2.414 mm)
3 ft 11 in (1.185 mm)	27.6°	45.7 psi (3,22 kgf/cm ²)	3 ft 11.9 in (1.218 mm)	7 ft 7.8 in (2.332 mm)
5 ft 4 in (1.635 mm)	21.8°	63.1 psi (4,45 kgf/cm ²)	2 ft 10.5 in (877 mm)	7 ft 2.18 in (2.189 mm)

The stability angle (a) is calculated according to European Standard BS EN 16228-1:2014.

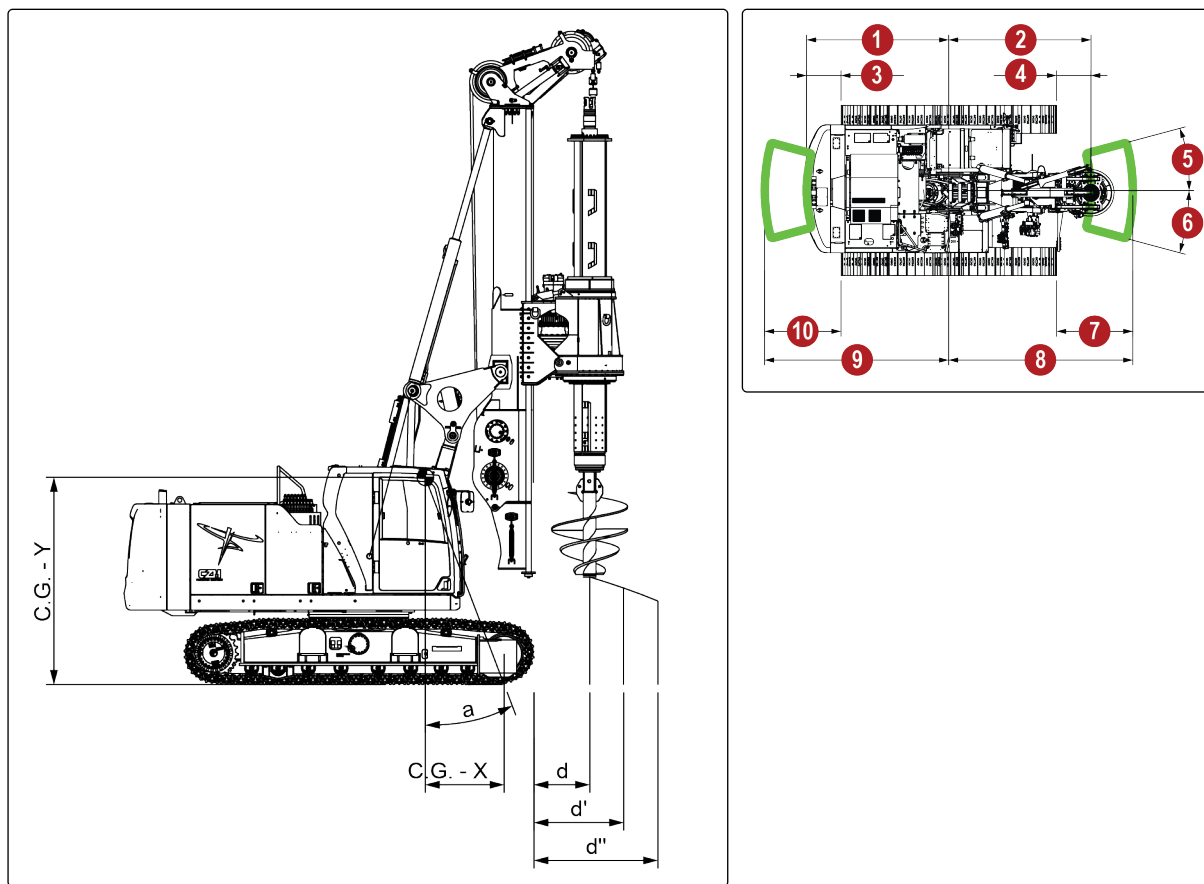

i NOTICE

- The maximum allowed main winch pull force is 41,000 lbf (18.600 kgf)
- The maximum force can be applied when the center of the tool is inside the safe zone specified above.

Table 29. Short Mast Drilling Stability-Forward Facing-Top View

Pos.	Value
1	10 ft (3.045 mm)
2	10 ft (3.045 mm)
3	2 ft 5 in (735 mm)
4	2 ft 5 in (735 mm)
5	15°
6	15°
7	5 ft 4 in (1.635 mm)
8	12 ft 11 in (3.945 mm)
9	12 ft 11 in (3.945 mm)
10	5 ft 4 in (1.635 mm)

Table 30. Short Mast Drilling Stability-Forward Facing-Conditions

Values are valid within the following conditions:	
Mast	Upright position
Undercarriage tracks	Spread
Counterweight	13,227 lb (6.000 kg)
Machine	On firm horizontal and even surface
Track shoes	23.6 in (600 mm)
Kelly bar	5 elements, 55 ft (16.764 mm) / 5,511 lb (2.500 kg)
Drilling tool	3,307 lb (1.500 kg)
Permissible wind speed	45 mph (72,4 km/h)

WARNING

In the case of different configurations, these values are no longer valid, and they must be recalculated. Contact CZM After Sales Department for details.
Failure to follow this warning could result in death or serious injury.

5.3.2.4. Drilling - Off The Side

Table 31. Short Mast Drilling Stability-Off The Side

Distance (d)	Stability Angle (a)	Ground Pressure (G.P.)	C.G. X	C.G. Y
4 ft (1.220 mm)	23.7°	20.6 psi (1,45 kgf/cm ²)	1 ft 8.3 in (1.060 mm)	8 ft 11.5 in (2.414 mm)
5 ft 6 in (1.670 mm)	17.1°	24.1 psi (1,7 kgf/cm ²)	2 ft 4.2 in (718 mm)	7 ft 7.8 in (2.332 mm)
7 ft (2.120 mm)	9.7°	27.5 psi (1,94 kgf/cm ²)	1 ft 2.8 in (376 mm)	7 ft 2.1 in (2.189 mm)

The stability angle (a) is calculated according to European Standard BS EN 16228-1:2014.

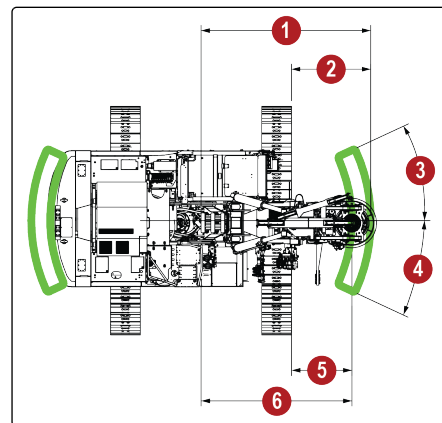
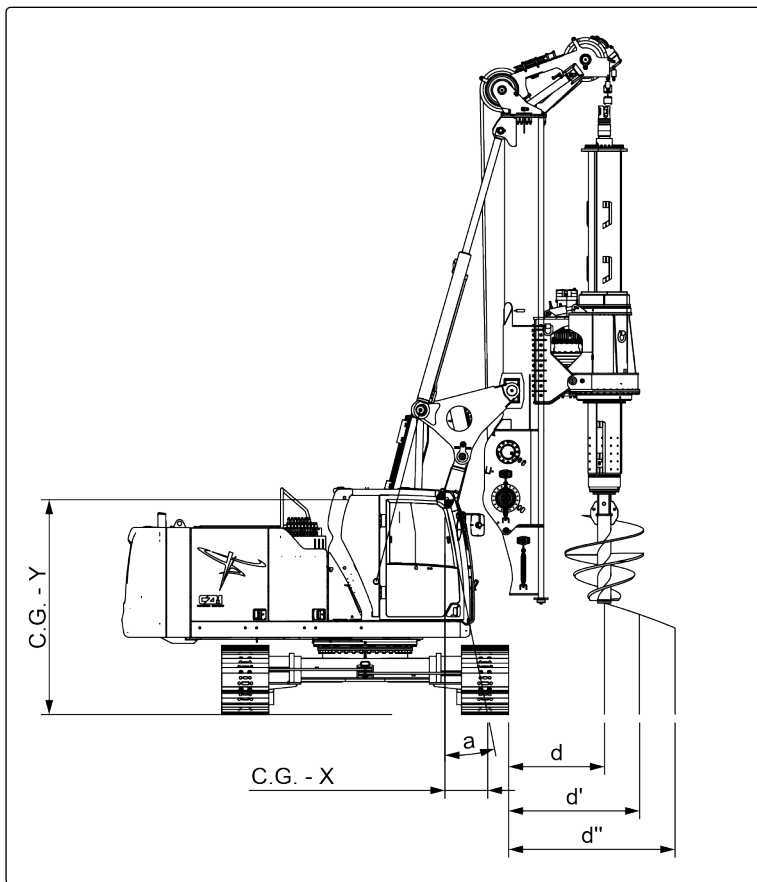

i NOTICE

- The maximum allowed main winch pull force is 41,000 lbf (18.600 kgf)
- The maximum force can be applied when the center of the tool is inside the safe zone specified below.

Table 32. Short Mast Drilling Stability-Forward Facing-Conditions

Pos.	Value
1	12 ft 11 in (3.945 mm)
2	6 ft 11 in (2.120 mm)
3	25°
4	25°
5	4 ft (1.220 mm)
6	10 ft (3.046 mm)

Table 33. Short Mast Drilling Stability-Off The Side-Conditions

Values are valid within the following conditions:	
Mast	Upright position
Undercarriage tracks	Spread
Counterweight	13,227 lb (6.000 kg)
Machine	On firm horizontal and even surface
Track shoes	23.6 in (600 mm)
Kelly bar	5 elements, 55 ft (16.764 mm) / 5,511 lb (2.500 kg)
Drilling tool	3,307 lb (1.500 kg)
Permissible wind speed	45 mph (72,4 km/h)

WARNING

In the case of different configurations, these values are no longer valid, and they must be recalculated. Contact CZM After Sales Department for details.
Failure to follow this warning could result in death or serious injury.

5.3.2.5. Auxiliary Winch - Forward Facing Tilted

Table 34. Short Mast Auxiliary Winch Stability-Forward Facing

Distance (d)	Stability Angle (a)	Ground Pressure (G.P.)	C.G. X	C.G. Y
5 ft (1.550 mm)	24.4°	39.7 psi (2,79 kgf/cm ²)	3 ft 9.7 in (1.161 mm)	8 ft 4.7 in (2.558 mm)

The stability angle (a) is calculated according to European Standard BS EN 16228-1:2014.

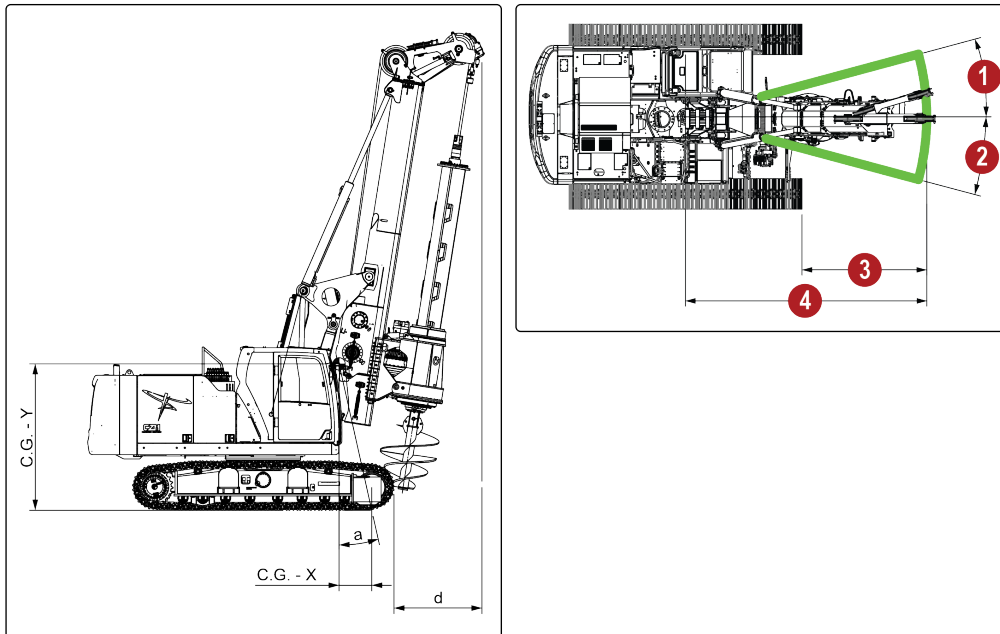

i NOTICE

- The maximum allowed pick-up weight is 22,046 lb (10.000 kg).
- The maximum force can be applied when the parallelogram is all the way back.
- The mast can be tilted forward.
- The machine can only swing 15° to each side on this configuration.

Table 35. Short Mast Auxiliary Winch Stability-Forward Facing-Top View

Pos.	Value
1	15°
2	15°
3	5 ft 1 in (1.550 mm)
4	12 ft 8 in (3.860 mm)

Table 36. Short Mast Auxiliary Winch Stability-Forward Facing-Conditions

Values are valid within the following conditions:	
Mast	Tilted forward up to 9°

Values are valid within the following conditions:	
Boom	All the way back
Undercarriage tracks	Spread
Counterweight	13,227 lb (6.000 kg)
Machine	On firm horizontal and even surface
Track shoes	23.6 in (600 mm)
Accessories (kelly bar, tooling, rotary)	Lowered as close to the ground as possible
Kelly bar	5 elements, 55 ft (16.764 m) / 5,511 lb (2.500 kg)
Drilling tool	3,307 lb (1.500 kg)
Permissible wind speed	45 mph (72,4 km/h)

WARNING

In the case of different configurations, these values are no longer valid, and they must be recalculated. Contact CZM After Sales Department for details.
Failure to follow this warning could result in death or serious injury.

5.3.2.6. Auxiliary Winch - Off The Side Tilted

Table 37. Short Mast Auxiliary Winch Stability-Off The Side Tilted

Distance (d)	Stability Angle (a)	Ground Pressure (G.P.)	C.G. X	C.G. Y
6 ft 8 in (2.030 mm)	15.5°	22.0 psi (1,55 kgf/cm ²)	2 ft 3.8 in (707 mm)	8 ft 5.6 in (2.583 mm)

The stability angle (a) is calculated according to European Standard BS EN 16228-1:2014.

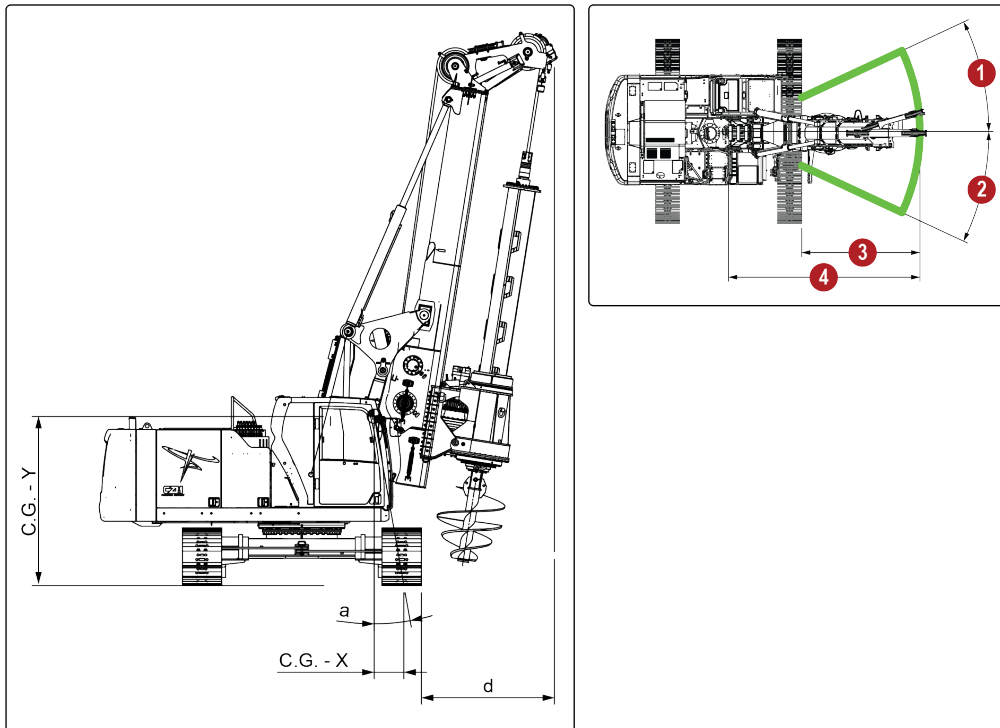

i NOTICE

- The maximum allowed pick-up weight is 22,046 lb (10.000 kg).
- The maximum force can be applied when the parallelogram is all the way back.
- The machine can only swing 25° to each side on this configuration.

Table 38. Short Mast Auxiliary Winch Stability-Off The Side Tilted-Top View

Pos.	Value
1	25°
2	25°
3	6 ft 8 in (2.030 mm)
4	12 ft 8 in (3.860 mm)

Table 39. Short Mast Auxiliary Winch Stability-Off The Side Tilted-Conditions

Values are valid within the following conditions:	
Mast	Tilted forward up to 9°
Boom	All the way back
Undercarriage tracks	Spread
Counterweight	13,227 lb (6.000 kg)
Machine	On firm horizontal and even surface
Track shoes	23.6 in (600 mm)
Accessories (kelly bar, tooling, rotary)	Lowered as close to the ground as possible
Kelly bar	5 elements, 55 ft (16.764 m) / 5,511 lb (2.500 kg)
Drilling tool	3,307 lb (1.500 kg)
Permissible wind speed	45 mph (72,4 km/h)

WARNING

In the case of different configurations, these values are no longer valid, and they must be recalculated. Contact CZM After Sales Department for details.

Failure to follow this warning could result in death or serious injury.

5.4. DANGER ZONES



IMPORTANT

Carefully read and understand what is written in *Personnel* (page 67).



DANGER

- Always respect the safety distances shown in the figures.
- Always respect the stability conditions. Refer to *Stability and Ground Pressure* (page 139).
- Access to danger zones is only allowed to authorized personnel which must be coordinated by the Operator.
- Before traveling or operating the machine, always check that nobody is inside the danger zone.
- Perform an inspection of the area where the machine will have to travel to check for any obstacles in advance.
- When traveling, choose the best travel path considering the characteristics of the machine (ground pressure, overall dimensions, and slopes that can be overcome).
- The following conditions are valid for the standard kelly bar version. Values must be recalculated for different versions.
Contact CZM After Sales Department for details.
- The following conditions must be re-evaluated in the case of soft soils.
Contact CZM After Sales Department for details.

5.4.1. Traveling-Vertical Mast

Figure 89.

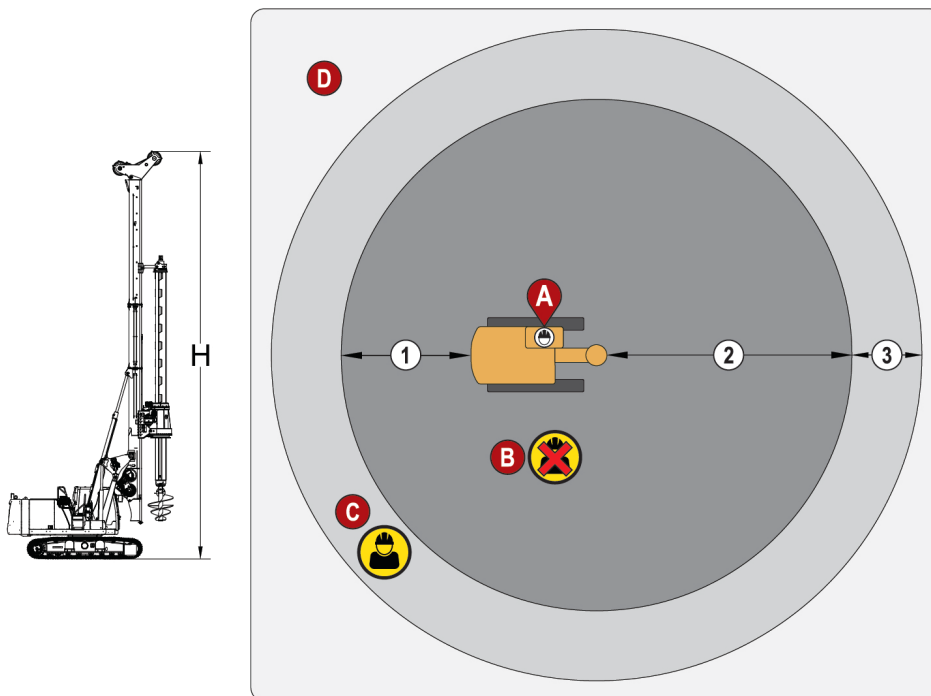

0000472-Danger Zones-Traveling-Vertical Mast

Table 40. Danger Zones-Traveling-Vertical Mast

Pos.	Description
1	32.8 ft (10.000 mm)
2	H+6.5 ft (H+2.000 mm)
3	16.4 ft (5.000 mm)

Zone	Description
A	<p>Operator's Workplace The Operator must be inside the cab while using the machine.</p> <div style="border: 2px solid red; border-radius: 15px; padding: 10px; background-color: #f08080; display: inline-block;">  <p>DANGER In addition to the operator in the cab, no other people must be on the machine during operation.</p> </div>
B	<p>Danger Zone Access to this zone is forbidden to all personnel.</p>
C	<p>Operator Assistant Zone The Operator Assistant can stay safe in this zone to communicate with the Operator.</p>
D	<p>Transit Zone Personnel and vehicles can stay safely in this zone.</p>

5.4.2. Traveling-Horizontal Mast

To travel within the job site, it may be necessary to lower the mast in a horizontal position with the Kelly mounted (for example to pass under a bridge). In this case, do not completely lower the mast, but keep it about 1 meter from the base.

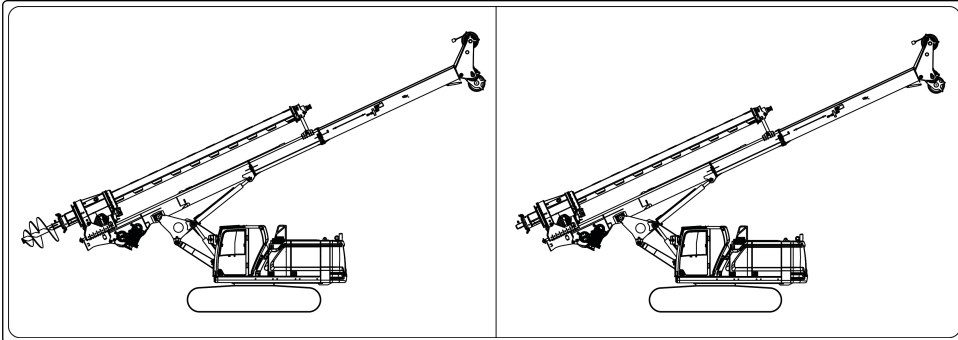

⚠ DANGER

Before moving the machine:

- Place the rotary in the lowest position.
- Place the Kelly bar in the lowest position.
- Lower the mast and keep it about 1 meter from the base.
- Undercarriage tracks must be fully extended.

Do not swing the base with the mast in the horizontal position.
Avoid any sudden movements or actions that may cause the machine to tip over.

Figure 90.

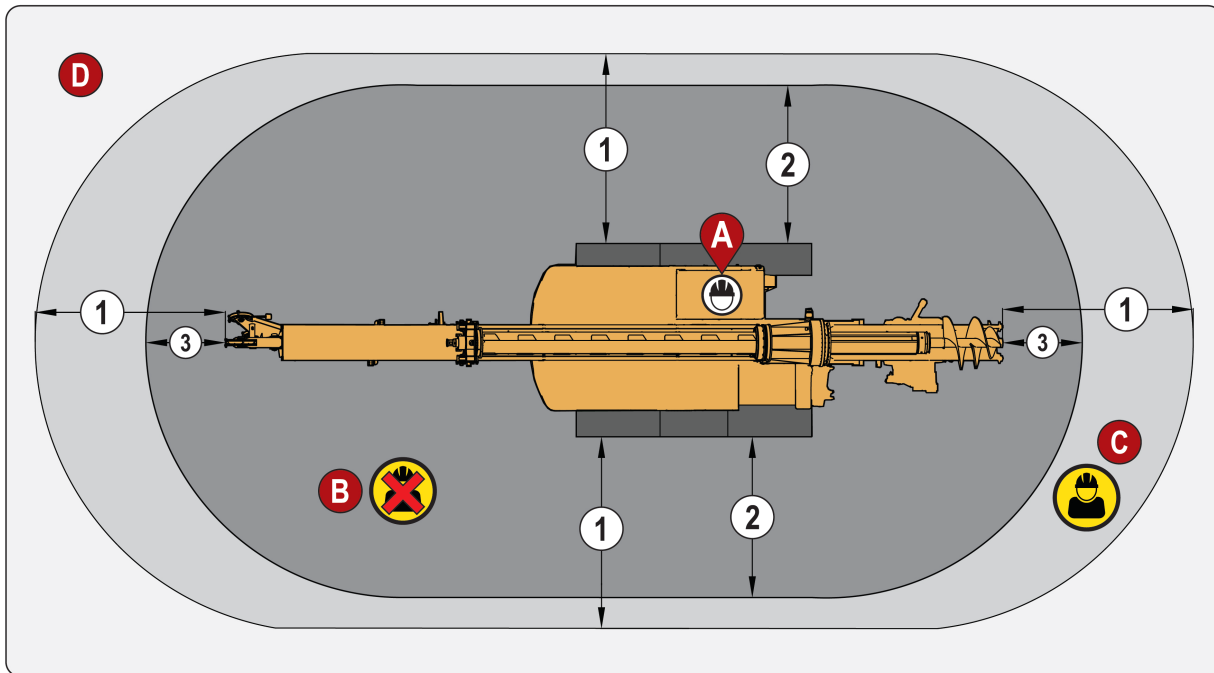

0000471-Danger Zones-Traveling-Horizontal Mast

Table 41. Danger Zones-Traveling-Horizontal Mast

Pos.	Description
1	39.4 ft (12.000 mm)
2	32.8 ft (10.000 mm)
3	16.4 ft (5.000 mm)

Table 42.

Zone	Description
A	<p>Operator's Workplace The Operator must be inside the cab while using the machine.</p> <div style="border: 2px solid red; background-color: #f08080; padding: 10px; border-radius: 15px;">  <p>DANGER In addition to the operator in the cab, no other people must be on the machine during operation.</p> </div>
B	<p>Danger Zone Access to this zone is forbidden to all personnel.</p>
C	<p>Operator Assistant Zone The Operator Assistant can stay safe in this zone to communicate with the Operator.</p>
D	<p>Transit Zone Personnel and vehicles can stay safely in this zone.</p>

5.4.3. Operation-Drilling

Figure 91.

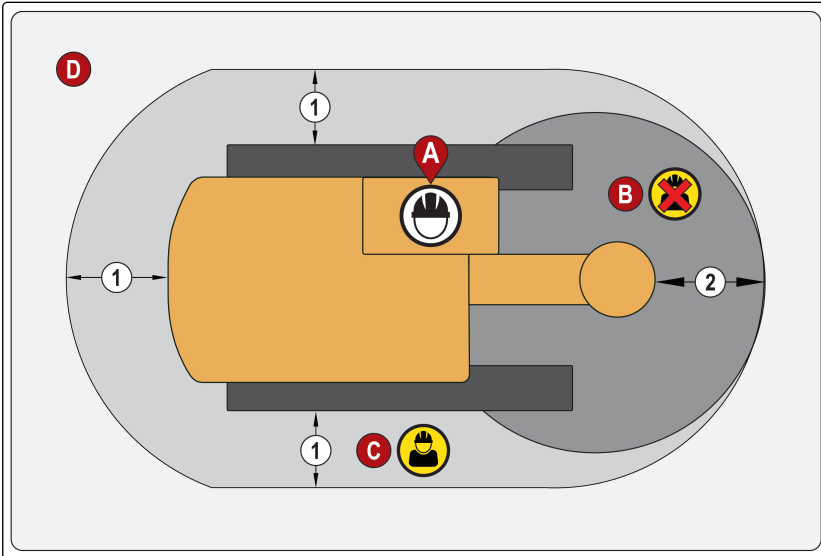

0000473-Danger Zones-Operation-Drilling

Table 43. Danger Zones-Operation-Drilling

Pos.	Description
1	9.84 ft (3.000 mm)
2	13.1 ft (4.000 mm)

Zone	Description
A	<p>Operator's Workplace The Operator must be inside the cab while using the machine.</p> <div style="background-color: #f00; padding: 10px; border: 1px solid #f00;"> <p> DANGER In addition to the operator in the cab, no other people must be on the machine during operation.</p> </div>
B	<p>Danger Zone Access to this zone is forbidden to all personnel.</p>
C	<p>Operator Assistant Zone The Operator Assistant can stay safe in this zone to communicate with the Operator.</p>
D	<p>Transit Zone Personnel and vehicles can stay safely in this zone.</p>

5.4.4. Operation-Spin-Off

Figure 92.

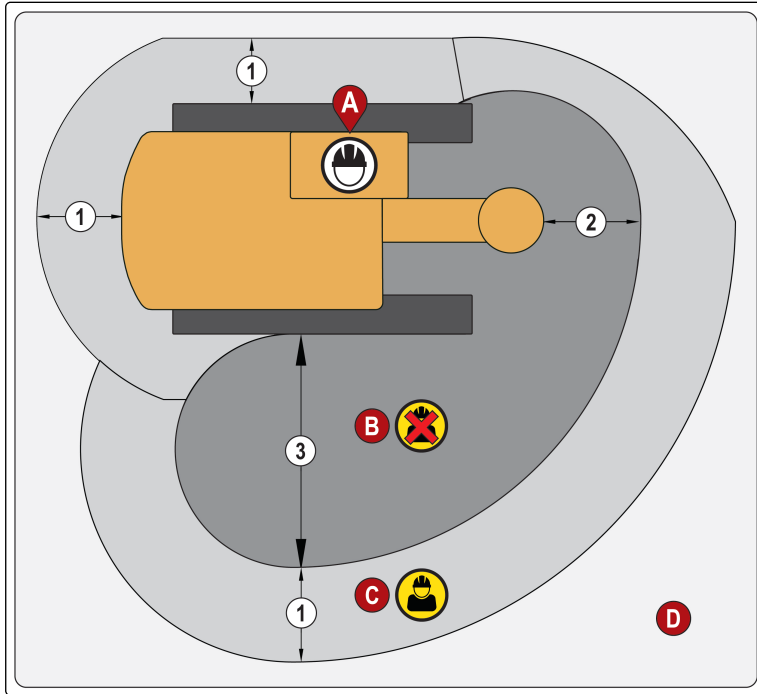

0000475-Danger Zones-Operation-Spin Off

Table 44. Danger Zones-Operation-Spin Off

Pos.	Description
1	9.84 ft (3.000 mm)
2	13.1 ft (4.000 mm)
3	32.8 ft (10.000 mm)

Zone	Description
A	<p>Operator's Workplace The Operator must be inside the cab while using the machine.</p> <div style="background-color: #f00; padding: 10px; border: 1px solid #000;"> <p> DANGER In addition to the operator in the cab, no other people must be on the machine during operation.</p> </div>
B	<p>Danger Zone Access to this zone is forbidden to all personnel.</p>
C	<p>Operator Assistant Zone The Operator Assistant can stay safe in this zone to communicate with the Operator.</p>
D	<p>Transit Zone Personnel and vehicles can stay safely in this zone.</p>

5.4.5. Operation-Machine Stopped

Figure 93.

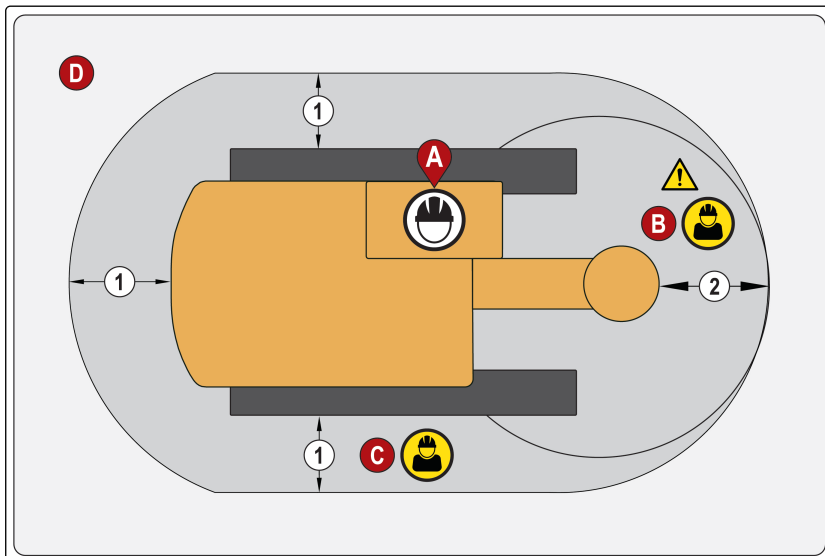

0000474-Danger Zones-Operation-Machine Stopped

Table 45. Danger Zones-Operation-Operation-Machine Stopped

Pos.	Description
1	9.84 ft (3.000 mm)
2	13.1 ft (4.000 mm)

Zone	Description
A	<p>Operator's Workplace The Operator must be inside the cab while using the machine.</p> <div style="background-color: #f08080; padding: 10px; border: 1px solid black;"> <p> DANGER In addition to the operator in the cab, no other people must be on the machine during operation.</p> </div>
B	<p>Danger Zone</p> <div style="background-color: #f08080; padding: 10px; border: 1px solid black;"> <p> DANGER</p> <ul style="list-style-type: none"> • Access is allowed only to authorized personnel. • The authorized personnel can approach the machine only if the machine is stopped and with no possibility of being activated. • The authorized personnel can only approach the machine for operations concerning the job execution and only for the time needed. </div>
C	<p>Operator Assistant Zone The Operator Assistant can stay safe in this zone to communicate with the Operator.</p>
D	<p>Transit Zone Personnel and vehicles can stay safely in this zone.</p>

5.4.6. Transportation

Figure 94.

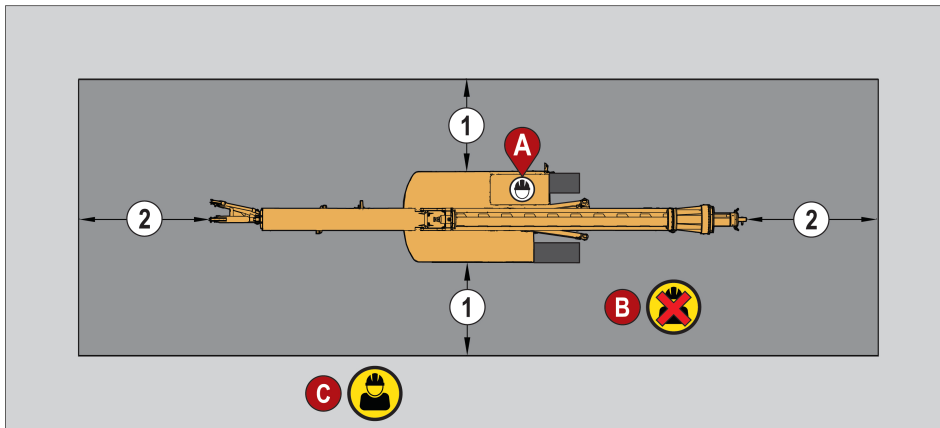

0000476-Danger Zones-Transportation

Table 46. Danger Zones-Transportation

Pos.	Description
1	16.4 ft (5.000 mm)
2	26.2 ft (8.000 mm)

Zone	Description
A	<p>Operator's Workplace The Operator must be inside the cab while using the machine.</p> <div style="border: 1px solid black; background-color: #f08080; padding: 10px; margin-top: 10px;"> <p> DANGER In addition to the operator in the cab, no other people must be on the machine during operation.</p> </div>
B	<p>Danger Zone Access to this zone is forbidden to all personnel.</p>
C	<p>Operator Assistant Zone The Operator Assistant can stay safe in this zone to communicate with the Operator.</p>

5.5. LIMITS OF USE

The limits of use reported in this section are defined considering a specific version of the machine.



DANGER

If the machine is set up with a configuration other than that described, it is the user's responsibility to contact CZM USA CORP for an update of the information contained in this section.



WARNING

In the case of different configurations, these values are no longer valid, and they must be recalculated. Contact CZM After Sales Department for details.
Failure to follow this warning could result in death or serious injury.

Mast	Upright position
Boom	All the way back
Undercarriage tracks	Spread
Counterweight	13,227 lb (6.000 kg)
Accessories (kelly bar, tooling, rotary)	Lowered as close to the ground as possible
Track shoes	23.6 in (600 mm)
Kelly bar	4 elements, 120 ft (36.576 mm) / 10,031 lb (4.550 kg)
Drilling tool	3,307 lb (1.500 kg)

5.5.1. Sound and Vibration

5.5.1.1. Sound Level



WARNING

- Hearing protection may be needed when the machine is operated with an open operator station for extended periods or in a noisy environment.
- Hearing protection may be needed when the machine is operated with a cab that is not properly maintained, or when the doors and windows are open for extended periods or in a noisy environment.
- The machine is designed and constructed so that, in normal conditions of use, the risks due to the emission of noise are reduced to the minimum level. In any case, the use of PPE is recommended.

Obey all local and regional governmental regulations.

Table 47. Sound Level

Description	Sound Level	Test Method
Operator Sound Pressure Level	71 dB(A)	"ISO 6396:2008" ^a .
Exterior Sound Power Level	100 dB(A)	"ISO 6395:2008" ^b .

^aThe measurement was conducted at 70% of the maximum engine cooling fan speed. The sound level may vary at different engine cooling fan speeds. The measurement was conducted with the cab doors and the cab windows closed. The cab was properly installed and maintained.

^bThe measurement was conducted at 70% of the maximum engine cooling fan speed. The sound level may vary at different engine cooling fan speeds.

The sound levels listed above include both measurement uncertainty and uncertainty due to production variation.

5.5.1.2. Vibration

When the machine is operated according to the intended use, the hand/arm vibration of this machine is below 2.5 m/s².

The whole body vibration of this machine does not exceed 0.5 meters per second squared.

The measurement has been performed according to ISO 2631-1.



IMPORTANT

The value of the vibration emissions to which the whole body is subjected has been determined under particular operating and ground conditions, so it is not representative of the various conditions of use intended for the machine.

5.5.2. Auxiliary Winch

The purpose of the Auxiliary Winch is to mount accessories for drilling only within the maximum load area.

! WARNING

- Do not lift loads heavier than shown on the stability chart. Refer to *Section: "Stability and Ground Pressure "* (p. 139).
- Do not exceed the load limits or operating parameters of the auxiliary winch and hoist line.
- When lifting a load with the auxiliary winch rope, operators must never make use of the mast positioning cylinders to increase lifting ability. The pressure relief valve may not be able to protect the winch from very dangerous overloads.
- Tampering with the pressure relief valve for loads more than those allowed is prohibited.
- Do not swing the machine more than specified on the stability chart. Refer to *Section: "Stability and Ground Pressure "* (p. 139).
- Do not travel with a suspended load.
- Do not drag loads with the auxiliary winch.
- Carefully read and understand what is written in *Section: "Auxiliary Winch "* (p. 105).

Failure to follow this warning could result in death or serious injury.

Figure 95.

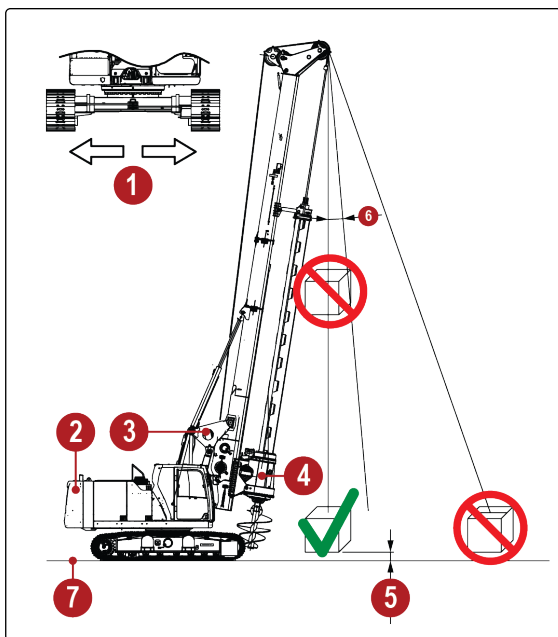

0000304 Auxiliary Winch-Limits of Use

Respect the following conditions to maintain the stability of the machine.

Table 48.

Pos.	Description
1	The undercarriage must be fully extended.
2	Counterweights must be installed.
3	The parallelogram must be positioned back.

Pos.	Description
4	The rotary, kelly bar, and auger must be positioned close to the ground.
5	Do not lift loads off the ground more than 1 ft. (300 mm).
6	The maximum angle for the auxiliary winch line is 5°.
7	The maximum slope on which the auxiliary winch can be used is 3°.

5.5.3. Traveling Up Hill

Figure 96.

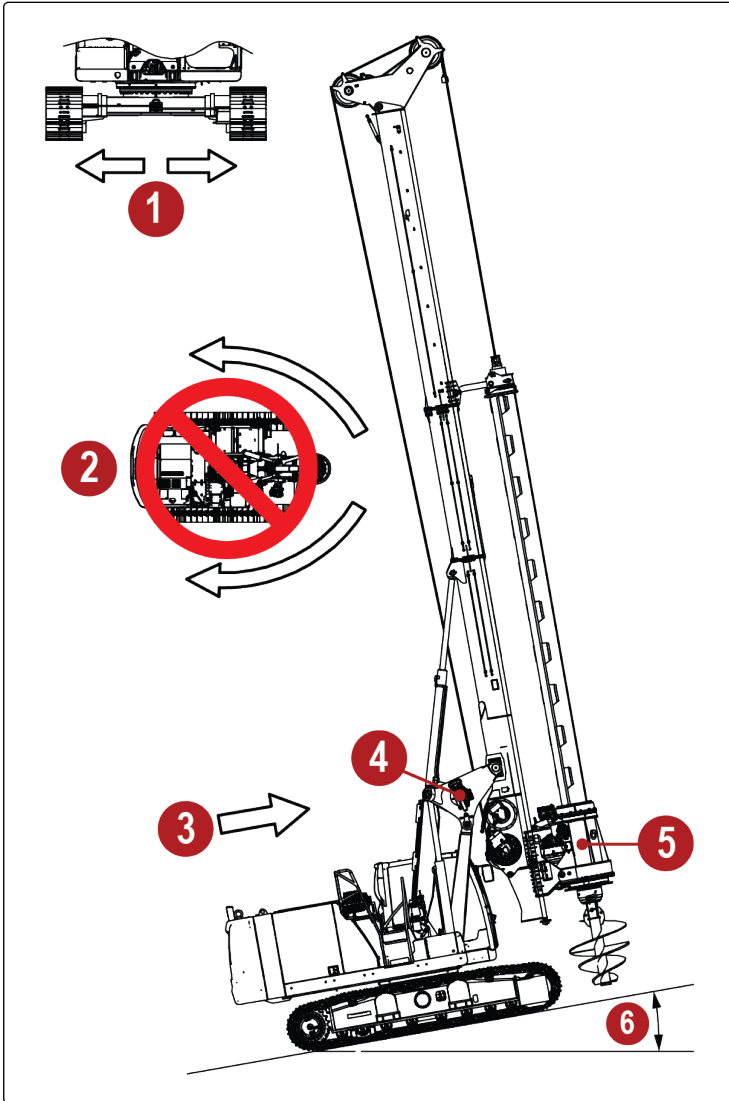

0000239 Traveling Up Hill

Respect the following conditions to maintain the stability of the machine.

1	The undercarriage must be fully extended.
2	Do not swing the machine.
3	Undercarriage facing forward.
4	Tilt the parallelogram all the way back.
5	The rotary, kelly bar, and auger must be positioned close to the ground.
6	Do not exceed 10°.

5.5.4. Traveling Down Hill

Figure 97.

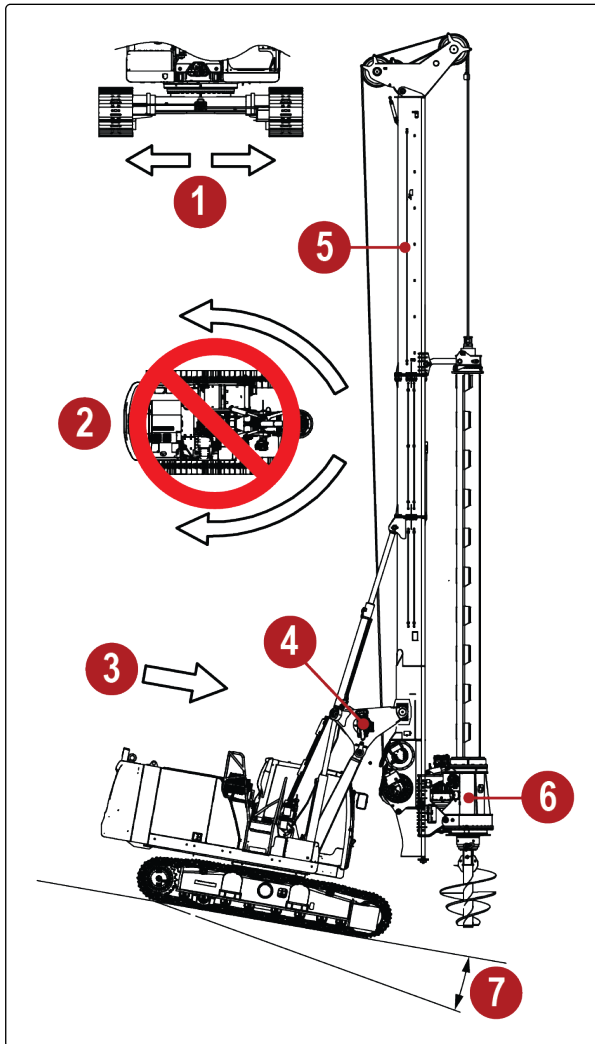

0000240 Traveling Down Hill

Respect the following conditions to maintain the stability of the machine.

1	The undercarriage must be fully extended.
2	Do not swing the machine.
3	Undercarriage facing forward.
4	Tilt the parallelogram all the way back.
5	Adjust the mast back so it is vertical or up to 3° back.
6	The rotary, kelly bar, and auger must be positioned close to the ground.
7	Do not exceed 10°.

5.5.5. Traversing Slopes

Figure 98.

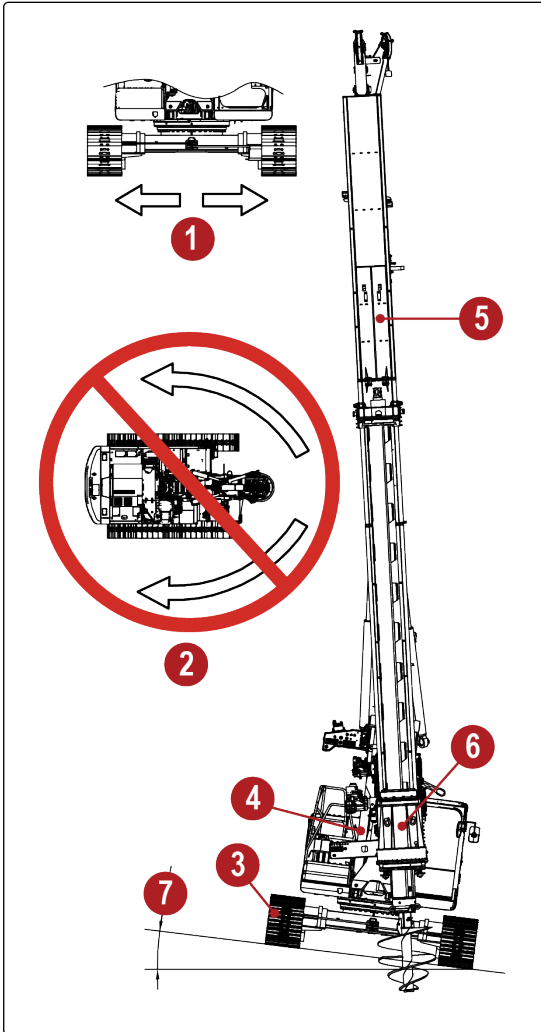

0000307 Traversing Slopes

Respect the following conditions to maintain the stability of the machine.

1	The undercarriage must be fully extended.
2	Do not swing the machine.
3	Undercarriage facing forward.
4	Tilt the parallelogram all the way back.
5	Align the mast to maintain the vertical position.
6	The rotary, Kelly bar, and auger must be positioned close to the ground.
7	Do not travel across gradients exceeding 7°.

5.5.6. Swing



WARNING

- Swing operation must be performed with extreme caution and care.
- Verify the area around the drilling rig is clear when performing swing operations.
- Fast, or sudden movements could result in loss of control and a tip over.
- Make sure the tracks are fully open to maintain base machine stability before performing swing operations.
- The operator does not have 360° visibility. Use extra caution when swinging the machine.
- Make sure there are no personnel or obstacles inside the machine area.
- Do not swing the machine more than specified on the stability chart. Refer to *Section: "Stability and Ground Pressure "* (p. 139).

Failure to follow this warning could result in death or serious injury.

Figure 99.

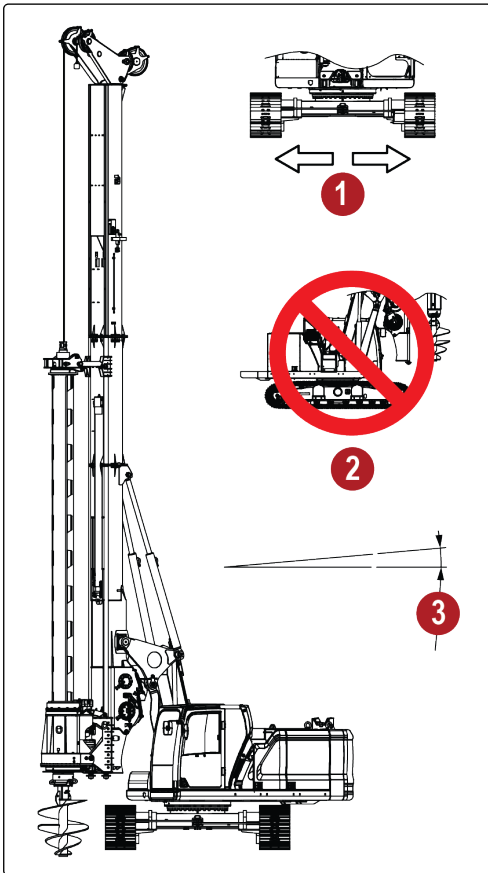

0000246 Swing Limits

Respect the following conditions to maintain the stability of the machine.

1	The undercarriage must be fully extended.
2	Counterweights must be installed.
3	Do not swing on a slope greater than 5°.

5.5.7. Mast Raising/Lowering

⚠ WARNING

- Do not raise or lower the mast with the undercarriage in the closed (unextended) position.
- Do not raise the mast without counterweights installed.
- Do not remove the counterweights with the mast raised above 30°.
- Make sure there are no personnel or obstacles inside the machine area.

Failure to follow this warning could result in death or serious injury.

Figure 100.

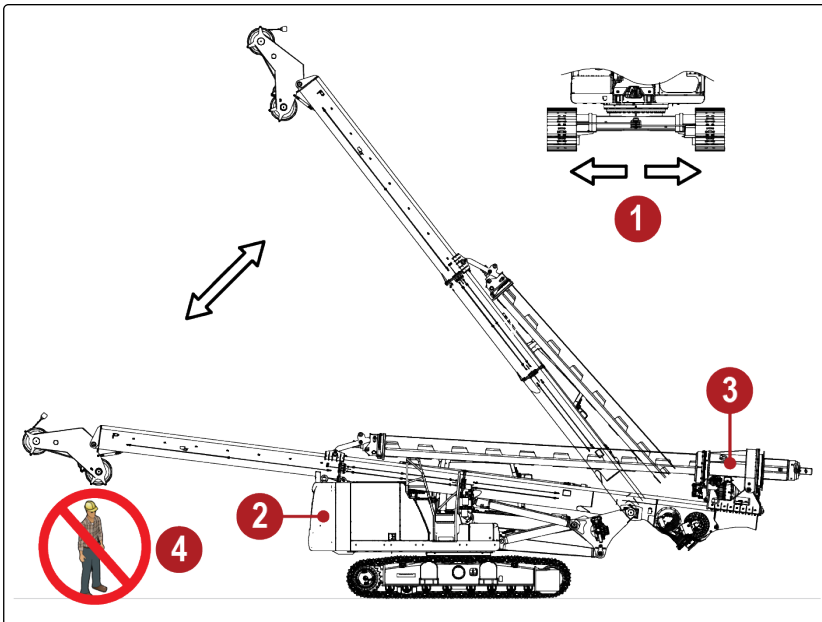

0000305 Mast Raising-Lowering Limits

Before raising or lowering the mast, respect the following conditions.

1	The undercarriage must be fully extended.
2	Counterweights must be installed.
3	The rotary, kelly bar, and auger must be positioned close to the ground.
4	All personnel must be outside the safety perimeter.

5.5.8. Mast Inclination

Figure 101.

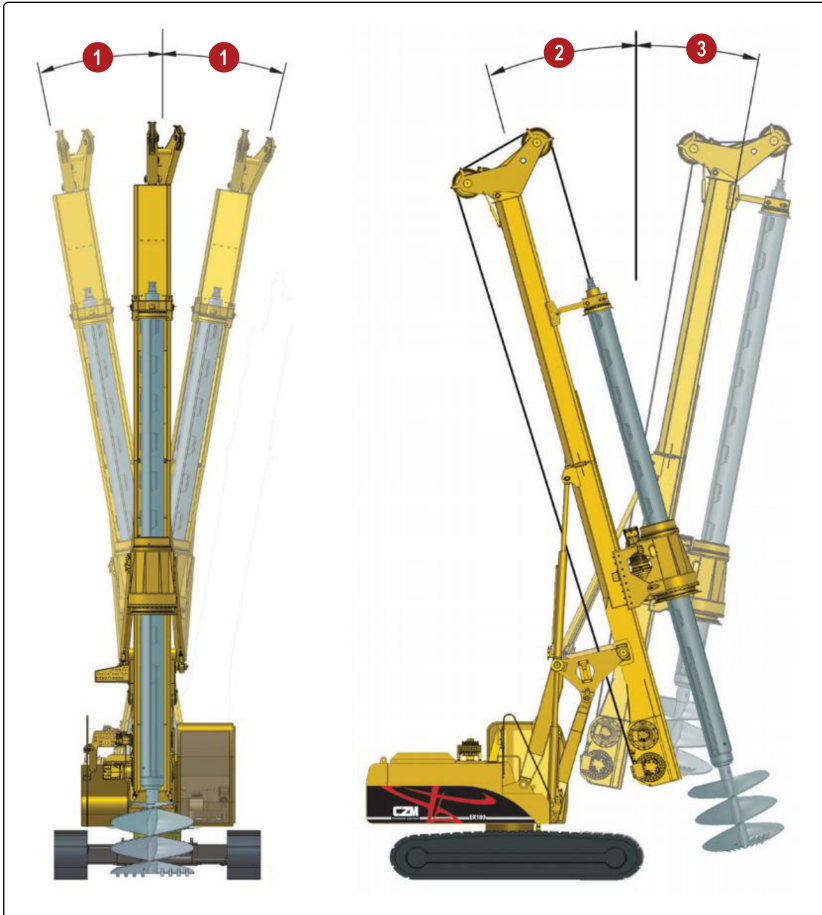

000223 Mast Tilting

1	9° / 9°
2	15°
3	9°

5.5.9. Environmental Limits

The machine operating and parking conditions are as follows.

Temperature range	0 ÷ +113 °F (-18 ÷ +45 °C)
Relative humidity range	0 ÷ 100%
Minimum atmospheric pressure	11.60 (0÷4921 ft) psi 0,8 (0÷1500m) bar
Corrosive atmospheric agents	Absent

i NOTICE
 Special configurations or special kits must be equipped on the machine in case of these temperatures:

- Lower than 32°F (0°C).
- Higher than 113°F (45°C).

Consult CZM after-sales support for additional information on special configurations of your machine.

! CAUTION

- It is forbidden to use the machine if the environmental limits do not correspond to those foreseen during the operation.
- If the machine has been exposed to environmental conditions that exceed the manufacturer limits, even with the engine off, it is necessary to carry out a preventive check before starting the machine;
- If prolonged exposure of the machine to the sun is expected, provide a cover to prevent the cab or engine compartment temperature from exceeding the maximum value indicated in the table.
- Depending on the expected temperatures, both during operation and at parking, the machine must be adapted by using different types of hydraulic oil, lubricating oil, as well as different concentrations of antifreeze in the engine cooling mixture.

5.5.9.1. Wind

! IMPORTANT
 Request a weather report in advance from the site manager to predict any abnormal weather conditions.

Greater than 31 mph (13.9 m/s)

It is not possible to use the auxiliary winch. Other drilling operations are allowed.

Greater than 45 mph (20 m/s)

The machine cannot work. When the wind speed exceeds this level, it is recommended to bring the machine in the parking configuration, with the support base of the mast (if equipped) in contact with the ground, rotary in the lowest position, and drilling equipment resting on the ground.

Greater than 56 mph (25 m/s)

The machine cannot work or be parked. When the wind speed exceeds this level, it is recommended to bring the machine into the transport configurations.

6. CONTROLS

6.1. ABOUT CONTROLS

This section provides all the information regarding the function and location of every control of the machine. The operator must acquire the necessary familiarity with all the elements, to maneuver it with maximum safety. Hydraulic controls are protected by an enabling device.



DANGER

- It is forbidden to start, test or operate the machine without first having carefully consulted this manual and being completely familiar with the relative controls. The correct methods of use and unauthorized maneuvers must be analyzed and understood, to avoid possible serious damage to people or things.
- The safety of the operator and people in the vicinity of the machine depends on the judgment and prudence of the operator himself. It is, therefore, necessary that whoever is about to operate the machine knows perfectly the position and the specific function of each control (standard and optional).

6.2. CONTROLS OVERVIEW

Figure 102.

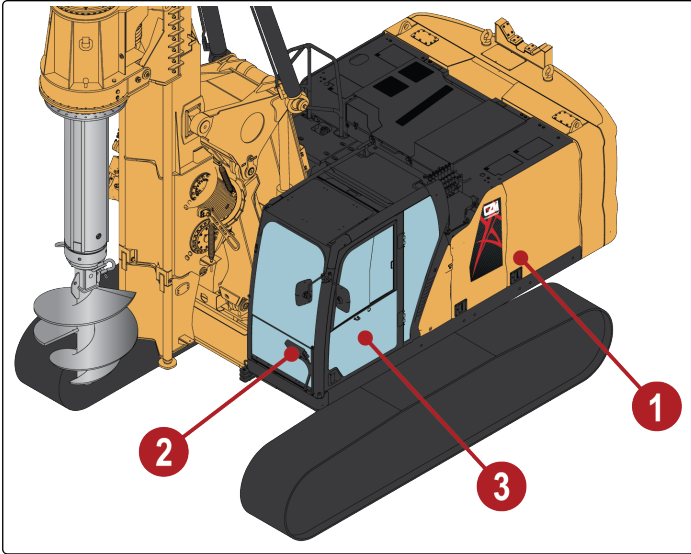

0000418 Controls Overview

Pos.	Description	Pg.
1	Battery Disconnect Switch	186
2	Pump Gauges	188
3	Cab Overview	189

6.3. BATTERY DISCONNECT SWITCH*

The battery disconnect switch is on the left side of the machine behind the rear access door.

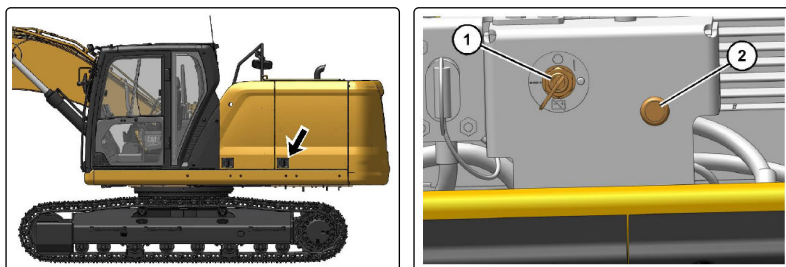

Pos.	Description
1	Battery disconnect switch
2	DEF purge light

For machines equipped with a circuit that stays activated for DEF purge with the disconnect switch off:

Figure 103.

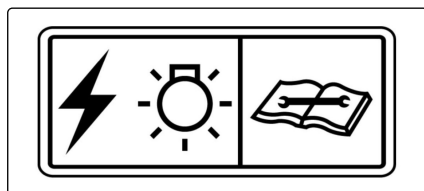

g03796564 DEF Purge Indicator Lamp

For machines not equipped with a circuit that stays activated for DEF purge with the disconnect switch off:

Figure 104.

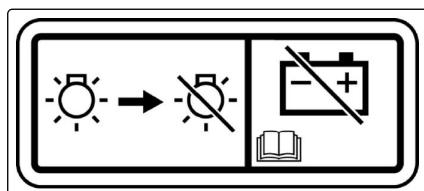

g03408962 DEF Purge Indicator Lamp-Circuit Not Activated for DEF Purge

! **IMPORTANT**

Do not conduct any service procedures on the DEF system until the DEF purge indicator lamp is not illuminated.

The indicator lamp may remain illuminated for several minutes, even though the battery disconnect switch is OFF and the engine start switch is OFF.

When the indicator lamp is on, the DEF system is still powered.

Battery Disconnect Switch – The battery disconnect switch can be used to disconnect the battery from the machine’s electrical system. The key must be inserted into the battery disconnect switch before the battery disconnect switch can be turned.



ON – To activate the electrical system, insert the disconnect switch key and turn the battery disconnect switch clockwise. The battery disconnect switch must be turned to the ON to enable battery power to start the engine.



OFF – To deactivate the electrical system, turn the battery disconnect switch counterclockwise to the OFF position.

The battery disconnect switch and the engine start switch perform different functions. The entire electrical system is disabled when you turn the battery disconnect switch to the OFF position. The battery remains connected to the electrical system when you turn the engine start switch to the OFF position.

Turn the battery disconnect switch to the OFF position and remove the key when you service the electrical system or any other machine components. If installed with a cover lock, close the cover and install a padlock.

Turn the battery disconnect switch to the OFF position and remove the key if you do not operate the machine for extended periods of a month or more. Turning off the disconnect switch will prevent the battery from being discharged.

A good practice is to use the disconnect switch after you operate the machine. Turning off the disconnect switch will prevent the battery from being discharged. The following problems can cause battery discharge:

- short circuits
- current draw via some components
- vandalism

Machines equipped with circuit for DEF purge: A special circuit stays energized with the disconnect switch in the OFF position. The Diesel Exhaust Fluid (DEF) purge circuit is supplied power from this circuit with the disconnect switch off. The special circuit ensures that the system will purge and no damage will be done to engine components.

Figure 105.

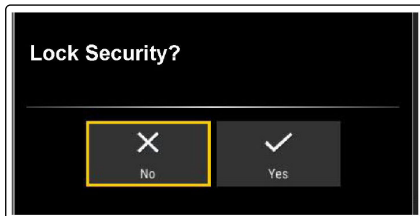

g06217247 Battery Disconnect Switch-Lock Security

Note: Do not turn off the battery disconnect switch until 5 seconds have elapsed after turning the engine start switch to the OFF position. Do not turn off the battery disconnect switch while the “Lock Security?” screen is displayed on the monitor. Both conditions would prevent the Diesel Exhaust Fluid (DEF) system from being purged and could cause DEF fluid to freeze in the lines.



IMPORTANT

Do not conduct any service procedures on the DEF system until the DEF purge indicator lamp is not illuminated.

The indicator lamp may remain illuminated for several minutes, even though the battery disconnect switch is OFF and the engine start switch is OFF.

When the indicator lamp is on, the DEF system is still powered.

Machines not equipped with circuit for DEF purge: If DEF purge light (2) is illuminated, wait for the light to turn off before turning the disconnect switch to the OFF position. Waiting for the light to turn off allows the DEF system to fully purge the exhaust fluid and prevents damage to engine components.

6.4. PUMP GAUGES

The main and auxiliary pump gauges are located outside the front windshield of the cab, to the left of the operator.

Figure 106.

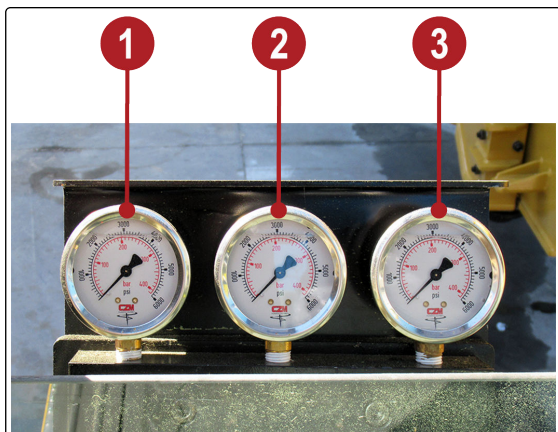

0000358 Pump Gauges

Pos.	Description
1	Pump P1 pressure
2	Pump P2 pressure
3	Pump P3 pressure

6.5. CAB OVERVIEW

Figure 107.

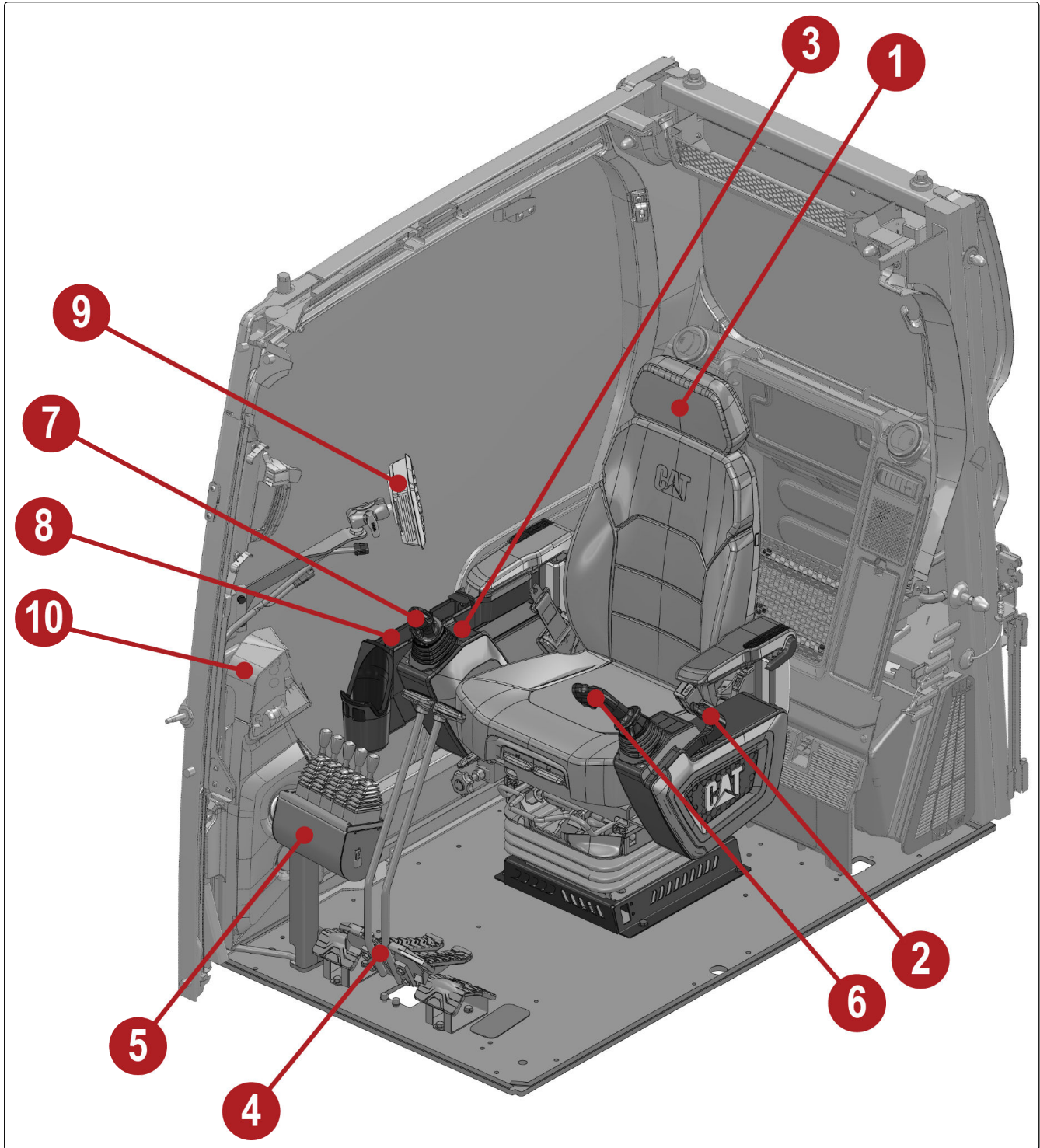

0000419 Cab Overview

Pos.	Description	Pg.
1	Operator Seat	191
2	Hydraulic Lockout Control	195
3	Engine Start Switch	196
4	Travel Controls	197
5	Function Levers	199
6	Left Joystick	201
7	Right Joystick	203
8	Right Side Switch Panel	205
9	CZM Monitor	209
10	CAT Monitoring System	232

6.5.1. Operator Seat*

Figure 108.

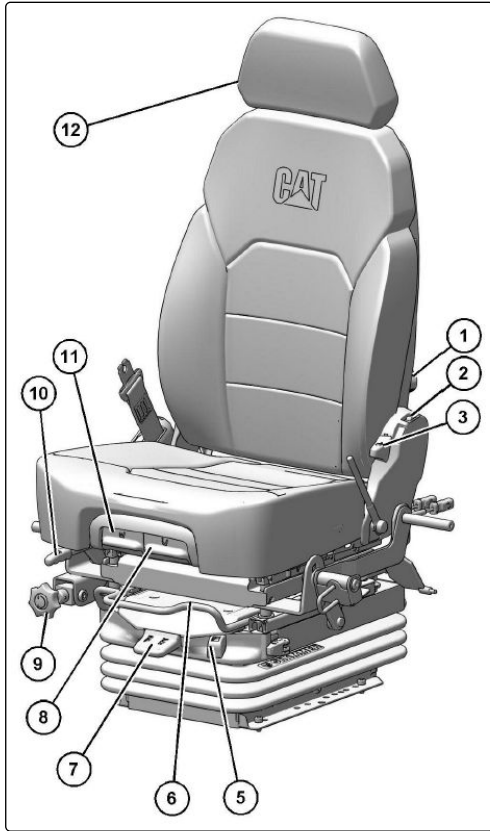

g06303504 Operator Deluxe Seat

Pos.	Description
1	Adjustment lever for the lumbar support
2	Seat heater switch
3	Adjustment lever for reclining the seat
5	Indicator
6	Seat and console fore and aft lever
7	Seat height adjustment
8	Seat cushion angle adjuster
9	Console height adjustment
10	Seat fore and aft adjuster
11	Seat cushion fore and aft adjuster
12	Headrest

6.5.1.1. Adjustment and Operation*

The lumbar support is located in the back of the seat:

- Turn knob (1) (if equipped) counterclockwise to increase the force of the lumbar support.
- To decrease the lumbar support, continue to turn the knob counterclockwise.

Seat heater switch (2) is a three-position switch:

- The middle position of the switch is off.
- Press the top position of the switch for low heat.
- Press the bottom of the switch for high heat.

Figure 109.

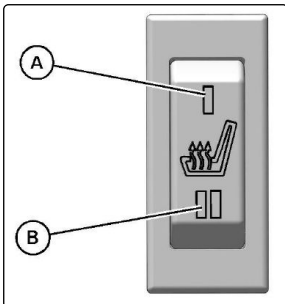

g06251600 Seat Heater Switch

POS.	DESCRIPTION
A	Low heat
B	High heat

WARNING
 Heat-induced burns can occur when some people use a seat heater.
 Do not use the seat heater if you have a reduced ability to sense temperature changes, a reduced ability to feel pain, or have sensitive skin.

Pull up lever (3) to change the angle of the backrest. With the backrest in the desired position, release the lever.

Push in adjuster (11) to adjust the fore/aft position of the seat cushion.

Pull lever (6) to adjust the seat and the console forward and backward.

Operate seat height adjustment (7) to adjust the seat and the console to the desired height:

- Pull up the lever to raise the height of the seat.
- Push down on the lever to lower the seat.
- Indicator (5) will turn green when the seat is at the optimum height for the operator's height and weight. If the indicator is yellow, further adjustment is required.

NOTICE
 Do not operate the seat compressor for over a minute or damage can result.

Use handle (9) to adjust the height of the console. When the lever is pulled forward, a gear is released. The operator can rotate the lever freely. Release the lever to return to the original position.

To adjust the seat forward or backward, pull up lever (10) and hold the lever. Move the seat to the desired position. To lock the seat in the selected position, release the lever.

Push adjuster (8) to adjust the tilt angle of the seat cushion.

The operator can adjust the height of headrest (12). To adjust the headrest:

1. Hold the headrest with both hands.
2. Move the headrest up and down.
3. Release the headrest when the desired position is attained.
4. The headrest will remain in the desired position.

6.5.1.2. Seat Belt*



NOTICE

The seat belt and the instructions for installation of the seat belt meet the SAE J386 and ISO 6683 standards.

Always check the condition of the seat belt and the condition of the mounting hardware before you operate the machine.

6.5.1.2.1. Fastening The Seat Belt

Figure 110.

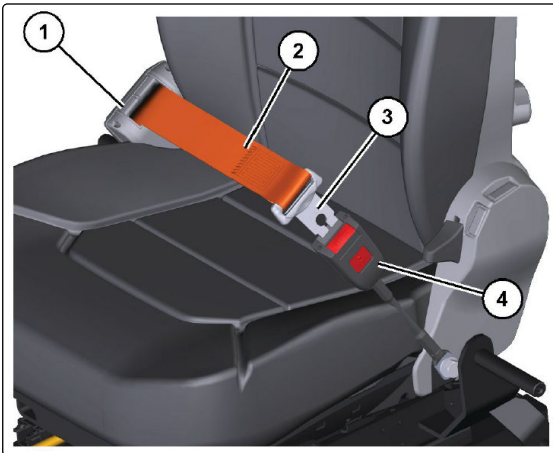

g06223891 Fastening The Seat Belt

1. Pull seat belt (2) out of retractor (1) in a continuous motion.
2. Fasten seat belt catch (3) into the buckle (4). Make sure that the seat belt is placed low across the lap of the operator.
3. The retractor will adjust the belt length and the retractor will lock in place. The comfort ride sleeve will allow the operator to have limited movement.

6.5.1.2.2. Releasing The Seat Belt

Figure 111.



g06223894 Releasing The Seat Belt

1. Push the release button on the buckle to release the seat belt.
2. The seat belt will automatically retract into the retractor.

6.5.1.2.3. Extension of the Seat Belt



WARNING

When using retractable seat belts, do not use seat belt extensions, or personal injury or death can result. The retractor system may or may not lock up depending on the length of the extension and the size of the person.
If the retractor does not lock up, the seat belt will not retain the person.

Longer, non-retractable seat belts and extensions for the non-retractable seat belts are available. Caterpillar requires only non-retractable seat belts to be used with a seat belt extension. Consult your Cat dealer for longer seat belts and for information on extending the seat belts.

6.5.2. Hydraulic Lockout Control*

The lever for the hydraulic lockout control is on the left side of the left console.



Locked – Move the travel levers/pedals and move the joysticks to the HOLD (center) position. Move the lever for the hydraulic lockout control backward to the LOCKED position. All the factory-installed hydraulic controls will become inoperable.



NOTICE

Make sure that the lever for the hydraulic lockout control is in the LOCKED position before attempting to start the engine. If the lever is in the UNLOCKED position, the engine start switch will not function.



Unlocked – Move the lever for the hydraulic lockout control forward to the UNLOCKED position. All the factory-installed hydraulic controls will become operable.

6.5.3. Engine Start Switch*

IMPORTANT
 For the correct procedure to start the engine, refer to the [Section: “Starting the Machine” \(page 266\)](#).

IMPORTANT
 The engine start switch must be in the ON position and the engine must be running in order to maintain electrical functions and hydraulic functions.
 This procedure must be followed in order to prevent serious machine damage.

Figure 112.

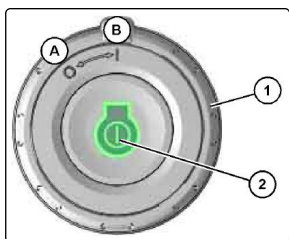

g06180554 Engine Start Switch

Pos.	Description
A	Off
B	On
1	Engine start ring
2	Start button

- OFF – Turn the engine start ring (1) to the OFF position (A) to stop the engine.
- ON – To activate the electrical circuits in the cab and enable engine starting, turn the engine start ring (1) clockwise to the ON position (B).
- START – To start the engine, enter the code on the monitor. Press start button (2). After the engine starts, release the button.

6.5.4. Travel Controls



IMPORTANT

Before moving the machine, check the position of the undercarriage. The normal travel position is with the idler wheels to the front under the cab and the drive sprockets to the rear. When the undercarriage is in the reversed position, the directional controls must be operated in opposite directions.

Control	Movement	Description
		Stop – Release the travel levers/pedals to stop the machine. When you release the travel levers/pedals from any position, the travel levers/pedals will return to the CENTER position. The travel brakes will be applied.
		Forward travel.
		Reverse travel.
		Pivot left turn (FORWARD).
		Pivot Left Turn (REVERSE).
		Counterrotate turn (LEFT).
		Pivot right turn (FORWARD).
		Pivot right turn (REVERSE).

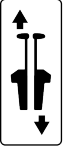
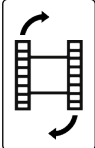
Control	Movement	Description
		<p>Counterrotate turn (RIGHT).</p>





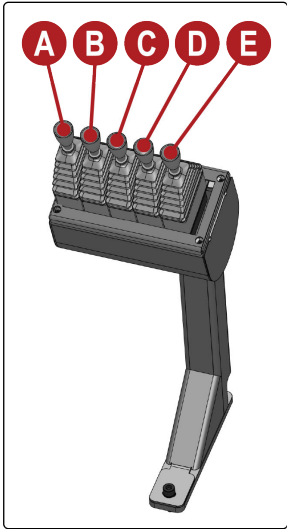

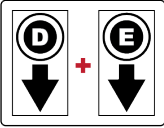

6.5.5. Function Levers

Figure 113.

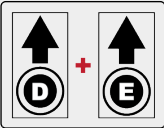

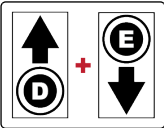
0000415 Function Levers

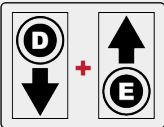
Control	Movement	Description
		Not used.
		Not used.
		Auxiliary winch lowering.
		Auxiliary winch raising.
		Parallelogram lowering.
		Parallelogram raising.





Control	Movement	Description
		Mast lowering.
		Mast raising.
		Mast tilting to the right.
		Mast tilting to the left.

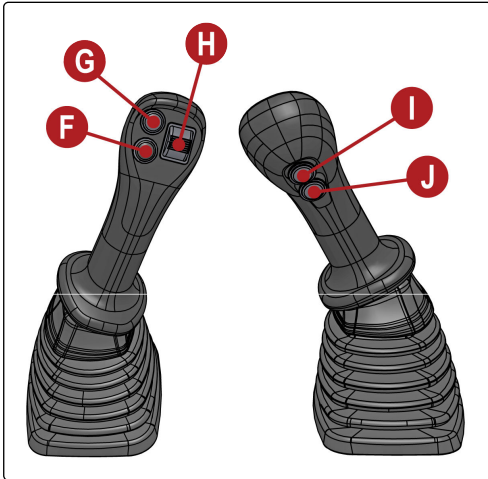

6.5.6. Left Joystick

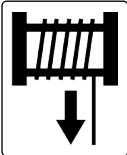
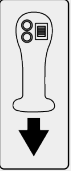
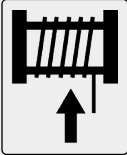
Figure 114.

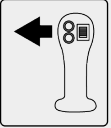

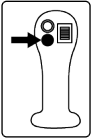
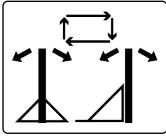
0000416 Left Joystick

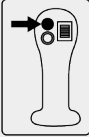
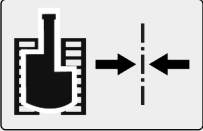
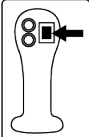
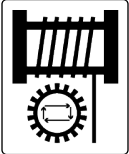
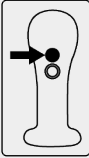
CONTROL	MOVEMENT	DESCRIPTION
		Main winch lowering.
		Main winch raising.
		Base swing clockwise.
		Base swing counterclockwise.
		Mast automatic leveling (F).

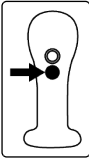
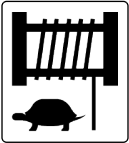





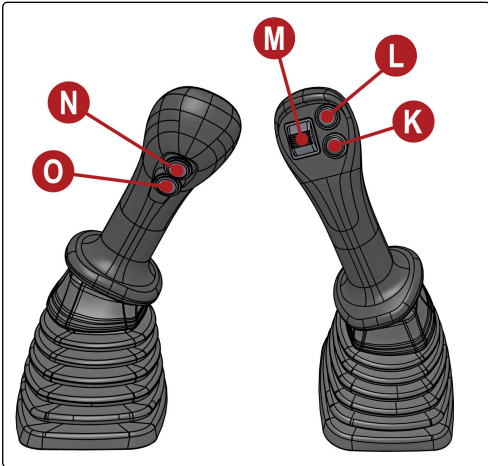

CONTROL	MOVEMENT	DESCRIPTION
		<p>Base swing - Return to center (G).</p>
		<p>Main winch - Auto shift (H).</p>
		<p>Horn (I).</p>
		<p>Main winch low speed (J).</p>



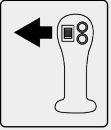

6.5.7. Right Joystick

Figure 115.

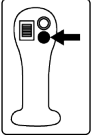
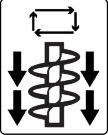

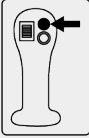
0000417 Right Joystick

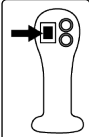
Control	Movement	Description
		Crowd.
		Pull up.
		Rotary counterclockwise.
		Rotary clockwise.
		Automatic drilling (K).

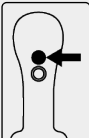
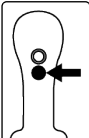
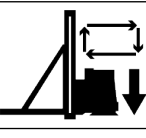
Control	Movement	Description
		Rotary spin-off (power shift) (L).
		Rotary speed (M).
		Not used (N).
		Automatic crowd (O).

6.5.8. Right Side Switch Panel*

Figure 116.

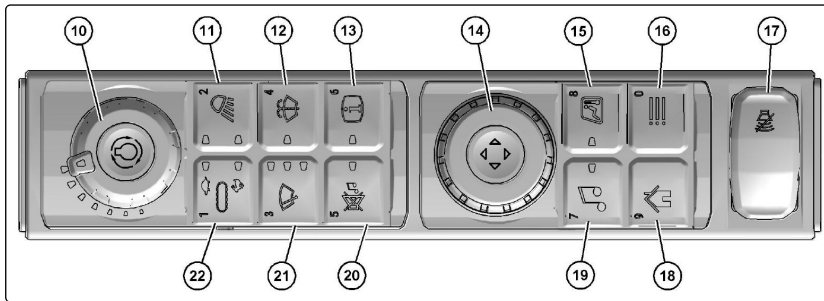

g06178333 Right Side Switch Panel



NOTICE

In addition to the intended functions, the buttons on the switch panel are numbered from 0-9. The numbered buttons can be used to enter numbers into the monitor for screens such as the passcode screen.

POS.	DESCRIPTION	P.
10	Engine speed/power mode control	205
11	Light switch	206
12	Window washer	206
13	Operator Information	206
14	Jog dial	206
15	Heating and air conditioning	206
16	Next menu	206
17	Travel alarm mute (If Equipped)	207
18	Home	207
19	Radio control	207
20	Radio mute switch	207
21	Window wiper	207
22	Travel speed control	207

6.5.8.1. Engine Speed/Power Mode Control (10)*

6.5.8.1.1. Engine Speed Control

Turn the dial to control the engine speed (engine rpm).

Select the desired position from the seven available positions:

- Turn the dial counterclockwise to decrease the engine speed (engine rpm).
- Turn the dial clockwise to increase the engine speed (engine rpm).

6.5.8.1.2. Power Mode Control

Push in the dial to change the power mode settings.

The Power Mode Control allows the operator to choose what power mode to operate the engine.

The modes that can be selected are: "ECONOMY", "SMART", and "POWER".



NOTICE

The default power mode setting can be set within the monitor. For more information, refer to *Power Mode Setting**.

6.5.8.2. Light Switch (11)*

Push the switch to turn on the work lights of the cab and base.

6.5.8.3. Window Washer (12)

Push the switch to activate the window washer.

While the switch is depressed, the indicator light will come on and washer fluid will spray from the nozzle.

The window wiper will also operate while the switch is depressed.

After the switch is released for approximately 3 seconds, the window wiper will stop.



NOTICE

- If the wiper does not operate with the switch in the ON position, turn the switch off immediately. Check the cause. If the switch remains on, motor failure can result.
- If the washer is used continuously for more than 20 seconds or used when no washer solution comes out, motor failure can result.

6.5.8.4. Operator Information (13)*

Press and hold this button to view the operator information screen.

The indicator light will illuminate when the button is pressed.

6.5.8.5. Jog Dial (14)*

The jog dial can be used to select items displayed on the monitor screen.

The dial can be rotated 360 degrees.

The dial can also be moved left, right, up, and down.

The dial can be pushed in to make a selection.

6.5.8.6. Air Conditioning and Heating (15)*

Press this button to bring up the air conditioning and heating menu.

The indicator light will illuminate when the heating and cooling system is active.

The jog dial (13) can be used to make selections. If equipped with a touch screen, the selections can be made by touching the monitor.

For more information refer to *Section: "Air Conditioning and Heating Control*" (page 244)*.

6.5.8.7. Next Menu (16)*

Press the next menu button to access the next higher menu.

If there is not a menu above the current screen being viewed, the button will not do anything.

For more information refer to *Section: "CAT Monitoring System*" (page 232)*.

6.5.8.8. Travel Alarm Mute Switch (17) (If Equipped)*

Press the travel alarm mute switch to mute the travel alarm.



NOTICE

The travel alarm will not sound when the travel levers or the travel pedals are activated.

6.5.8.9. Home (18)*

Press the home key to return to the default display at any time.

For more information refer to [Section: "CAT Monitoring System*" \(page 232\)](#).

6.5.8.10. Radio Control (19)*

Press this button to display the radio controls on the monitor.

The indicator light on the button will illuminate when the radio is turned on.

Use jog dial (14) to make selections.

If equipped with a touch screen display, touch the icons on the screens to make a selection.

For more information refer to [Section: "Radio*" \(page 240\)](#).

6.5.8.11. Radio Mute (20)*

Press the radio mute switch (20) to mute the radio.

The indicator light will illuminate when the mute is activated.

Press the button again to unmute the radio.

6.5.8.12. Window Wiper (21)*

Push the switch to activate the window wiper.

Whenever the switch is depressed, the mode of the window wiper will change according to the indicator light that is illuminated.

6 Second Delay – When the window wiper switch is depressed one time, the first indicator light will turn on. The window wiper will operate intermittently at six-second intervals.

3 Second Delay – When the window wiper switch is depressed two times, the second indicator light will turn on. The window wiper will operate intermittently at three-second intervals.

Continuous Operation – When the window wiper switch is depressed three times, the first indicator light and the second indicator light will turn on. The window wiper will operate continuously.

OFF – When the window wiper switch is depressed four times, the indicator lights will turn off. The window wiper stops.

6.5.8.13. Travel Speed Control (If Equipped) (22)*



WARNING

Do not change the setting of the travel speed control switch while you travel.

Machine stability may be adversely affected.

Failure to follow this warning could result in death or serious injury.

Press the travel speed control switch to select automatic travel speed or low travel speed.

When the engine start switch is on, the travel speed control switch is always set at the LOW-SPEED position.

Whenever the travel speed control switch is pressed, the travel speed changes.

The indicator lights illuminate to show which speed selection is active.

LOW SPEED – Select the LOW-SPEED position if you travel on rough surfaces or on soft surfaces or if you require a great drawbar pull. Also, select the LOW-SPEED position if you are loading a machine onto a trailer or you are unloading a machine from a trailer.

AUTOMATIC – If you travel on a hard, level surface at a fast speed, select the AUTO position.

**NOTICE**

Continuous driving at high speed should be limited to 2 hours.

If you need to continue driving at high speed for more than 2 hours, stop the machine for 10 minutes.

This process will cool down the travel drives before you resume driving.

6.6. CZM MONITOR

The EK125 drilling rig monitors the parameters of the equipment operation.
 The monitor displays active drilling rig sensor status.
 It gives the operator control over aspects of the drilling rig from the cab.

6.6.1. Starting

The monitor turns on automatically when the Engine Start Switch is in the ON position.
 The initial screen is shown in the figure below.

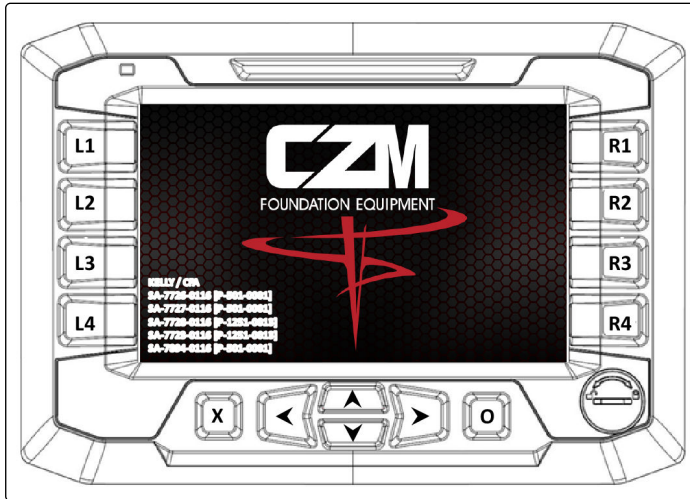

0000341 Monitor-Initial Screen

6.6.2. Home Screen

The Home Screen is displayed during the base machine start-up, and after the system performs its initial system scan.

On this screen, the operator can access basic information about equipment, and diagnose or bypass any safety system identified by their sensors.

Figure 117.

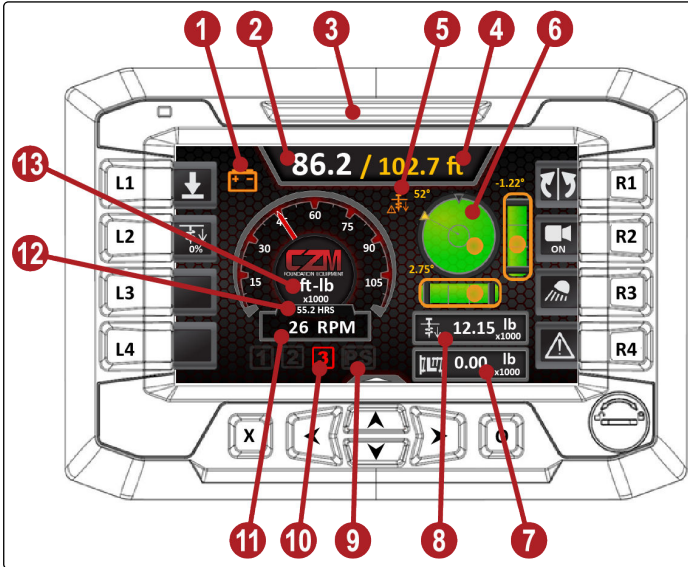

0000342 Monitor-Home Screen

Table 49.

Pos.	Name	Description
1	Battery Icon	The battery icon lights on when the alternator is not at charging voltage.
2	Current Drill Operation Depth Indicator	Displays the current depth of the kelly bar.
3	Fault Status – Light Emitting Diode (LED) Bar	The LED bar indicates if any faults are active: <ul style="list-style-type: none"> • Gray: There is no fault active. The system is ready for operation. • Red: The system scan failed. Operation is disabled. • Orange (blinking): A fault is active.
4	Maximum Drill Operation Depth Indicator	Displays the maximum depth of the kelly bar.
5	Over Crowd Warning	Displays when an over crowd condition occurs.
6	Mast Level Indicator	Displays the current angle of the mast on the X and Y axis direction.
7	Main Winch Force Indicator	Displays the main winch force during operation. The Crowd Winch Speed is also displayed: <ul style="list-style-type: none"> • (H) for high speed. • (L) for low speed.

Pos.	Name	Description
8	Crowd Force Indicator	Displays the crowd force during operation.
9	Power Shift Indicator	Displays when the power shift is activated.
10	Rotary Gear Indicator	Displays the operating rotary gear position.
11	Rotary RPM Indicator	Displays the rotary RPM during operation.
12	Hour Meter Indicator	The hour meter records system hours.
13	Rotary Torque Indicator	Displays the rotary torque during operation.

6.6.3. Home Screen Switch Functions

Switches from L1 to L4 are located on the left side of the monitor.
Switches from R1 to R4 are located on the right side of the monitor.



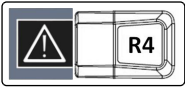

Figure 118.



0000420 Monitor-Home Screen Switch Functions

Table 50.

Name	Switch	Description
L1		Press and hold the switch to reset to zero the depth.
L2		Press and hold the switch to activate Auto Crowd and display the drilling progress.
L3	-	Not used.
L4	-	Not used.
R1		Press and hold the switch to set the current swing location as the hole center.
R2		ON —The swing camera view is on.
		OFF —The swing camera view is off.
		AUTO —The swing camera screen is automatically displayed during swinging operations.

Name	Switch	Description
R3		OFF —The mast lights are off and the mast light switch icon is off.
		ON —The mast lights are on and the mast light switch icon is illuminated.
R4		State 1 —No active faults present.
		State 2 (Flashing icon) —An active fault is present. Press the switch to access the Active Fault Message Screen. See Section: “Active Faults Screens ” (page 231) for more information.

6.6.4. Home Screen Settings

1. From the Home Screen, press the up arrow button (shown in the figure) to display the Home Screen Settings. Alternatively, push the small up arrow on the screen (above the up arrow button, not shown in the figure).

Figure 119.



0000424 Monitor-Home Screen-Settings Access

2. The following pop-up will appear.

Figure 120.



0000428 Monitor-Home Screen Settings

3. Press the left arrow button or right arrow button to highlight a function.



NOTICE

The selected function has a white outline.
It has also an up, down, left, and right arrow to select functions.

4. Once a function is selected (highlighted), press the up arrow button or down arrow button to select the function to change.
A function may also be selected by touching the screen on the up arrow icon or down arrow icon next to the white outline.

Figure 121.

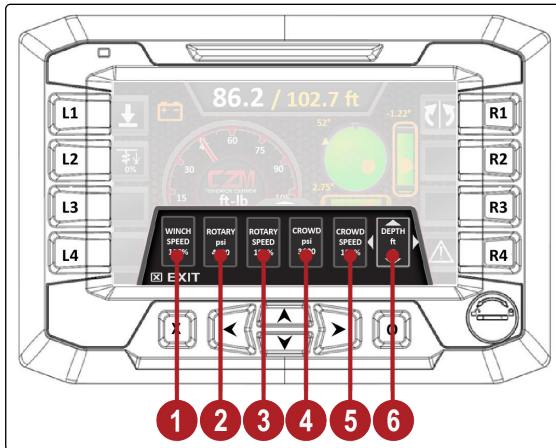

0000426 Monitor-Home Screen Settings Elements

Table 51.

Pos.	Name	Description
1	Main winch speed	This parameter adjusts the maximum output signal for the main winch function. As the winch speed output signal is increased, the winch speed increases up to maximum winch speed.
2	Rotary PSI	This parameter is used to adjust the rotary pressure for overcrowding prevention. Rotary pressure will reduce the crowd signal if the rotary pressure increases to avoid stalling the rotary. As the rotary pressure goes down, the crowd will resume.
3	Rotary speed	This parameter adjusts the maximum output signal for the rotary function. As the rotary speed output signal is increased, the rotary speed increases up to the maximum rotary speed.
4	Crowd PSI	This parameter is used to adjust the crowd pressure for overcrowding prevention. It will reduce the crowd signal if the crowd pressure increases to avoid overcrowding and damage to the kelly bar. As the crowd pressure decreases, the crowd operation will resume.
5	Crowd speed	This parameter adjusts the maximum output signal for crowd speed. As the crowd speed output signal increases, the crowd speed increases to maximum crowd speed.
6	Depth	This parameter is used during auto crowd operation. This is the total depth that will be drilled once the auto crowd is engaged. The depth should be set to match the length of the auger.

6.6.5. Second Screen

1. On the Home Screen, press the right arrow.

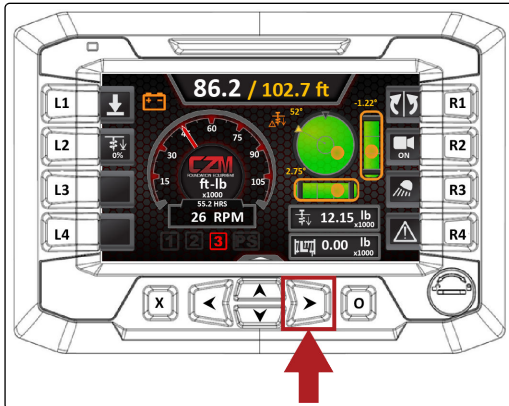

2. The Second Screen will appear (only lateral functions will change, as shown in the figure below).

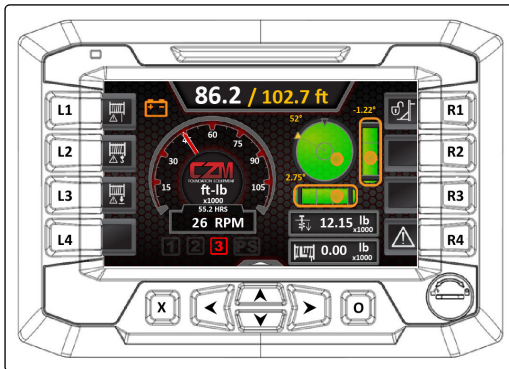

6.6.6. Second Screen Switch Functions

On the Second screen, the operator is able to access basic information on the equipment, and diagnose or bypass any system sensor.



WARNING

Bypassing the limit switches is very dangerous and can cause accidents with injuries or even death.

The bypass of the limit switches must be used only in these cases:

- Emergency, to bring the machine back to safety conditions.
- Assembly.
- Disassembly.
- Maintenance.

Maximum caution is required during operations.

Failure to follow this warning could result in death or serious injury.

Failure to follow this warning could result in damage to equipment or cause it to operate improperly.

Switches from L1 to L4 are located on the left side of the monitor.

Switches from R1 to R4 are located on the right side of the monitor.

Figure 122.

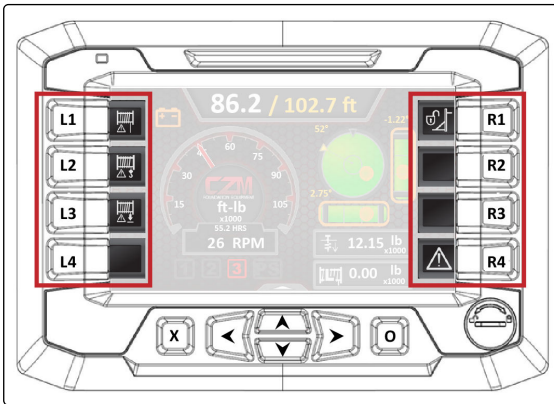

0000425 Monitor-Second Screen Switch Functions

6.6.6.1. L1–Main Winch Limit and Exclusion Switch



IMPORTANT

Functions Switches can operate in two ways (MOM and LATCH), which can be chosen in the Settings Screen.

The default setting is MOM (momentary).



WARNING

Bypassing the limit switches is very dangerous and can cause accidents with injuries or even death. The bypass of the limit switches must be used only in these cases:



- Emergency, to bring the machine back to safety conditions.
- Assembly.
- Disassembly.
- Maintenance.

Maximum caution is required during operations.

Failure to follow this warning could result in death or serious injury.

Failure to follow this warning could result in damage to equipment or cause it to operate improperly.

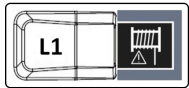
The **outer ring color** shows if the limit switch has reached or not its limit position (engagement).

Outer Ring Color	Description
	GRAY -The limit switch is not engaged.
	YELLOW -The limit switch is engaged.

The **icon color** shows the operation of the limit switch, which can be changed by pushing the Function Switch.

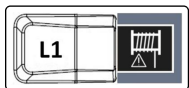
Icon Color	Description
	BLACK -The limit switch operates normally and it disables the winch raising.

Icon Color	Description
	RED -The limit switch has been bypassed and it always allows the winch raising.

The combination of these colors generates **4 different statuses** of the switch:

Status	Description
	The limit switch operates normally and it is not engaged.
	The limit switch has been bypassed and it is not engaged.
	The limit switch operates normally and it is engaged. The winch can't be raised over the limit position.
	The limit switch has been bypassed and it is engaged. The winch can be raised over the limit position.

6.6.6.2. L2–Auxiliary Winch Limit and Exclusion Switch

! IMPORTANT
 Functions Switches can operate in two ways (MOM and LATCH), which can be chosen in the Settings Screen.
 The default setting is MOM (momentary).

! WARNING
 Bypassing the limit switches is very dangerous and can cause accidents with injuries or even death. The bypass of the limit switches must be used only in these cases:

- Emergency, to bring the machine back to safety conditions.
- Assembly.
- Disassembly.
- Maintenance.



Maximum caution is required during operations.
 Failure to follow this warning could result in death or serious injury.
 Failure to follow this warning could result in damage to equipment or cause it to operate improperly.

The **outer ring color** shows if the limit switch has reached or not its limit position (engagement).

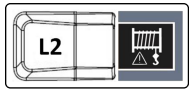

Outer Ring Color	Description
	GRAY -The limit switch is not engaged.

Outer Ring Color	Description
	YELLOW -The limit switch is engaged.

The **icon color** shows the operation of the limit switch, which can be changed by pushing the Function Switch.

Icon Color	Description
	BLACK -The limit switch operates normally and it disables the winch raising.
	RED -The limit switch has been bypassed and it always allows the winch raising.

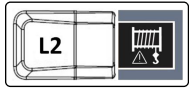
The combination of these colors generates **4 different statuses** of the switch:

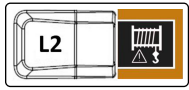
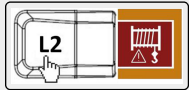
Status	Description
	The limit switch operates normally and it is not engaged.
	The limit switch has been bypassed and it is not engaged.
	The limit switch operates normally and it is engaged. The winch can't be raised over the limit position.
	The limit switch has been bypassed and it is engaged. The winch can be raised over the limit position.

6.6.6.3. L3–Main Winch Bottom Hole Exclusion Switch

! **IMPORTANT**
 Functions Switches can operate in two ways (MOM and LATCH), which can be chosen in the Settings Screen.
 The default setting is MOM (momentary).

Press the switch to change the function.

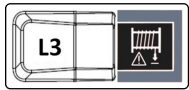
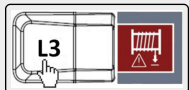
Function	Description
	BLACK -The limit switch operates normally and it disables the winch lowering when it reaches the hole bottom.
	RED -The limit switch has been bypassed and it always allows the winch's lowering when it reaches the hole bottom.

6.6.6.4. R1–Mast Lock Switch (If Equipped)

Press the switch to change the function.

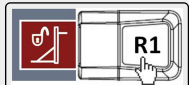
Function	Description
	<p>BLACK -Unlocked.</p>
	<p>RED -Locked.</p>

6.6.7. Second Screen Settings

- From the Second Screen, press the up arrow button (shown in the figure) to display the Second Screen Settings. Alternatively, push the small up arrow on the screen (above the up arrow button, not shown in the figure).

Figure 123.

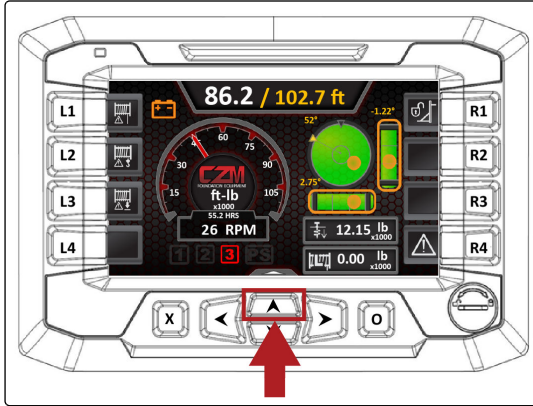

0000429 Monitor-Second Screen-Settings Access

- The following pop-up will appear.

Figure 124.

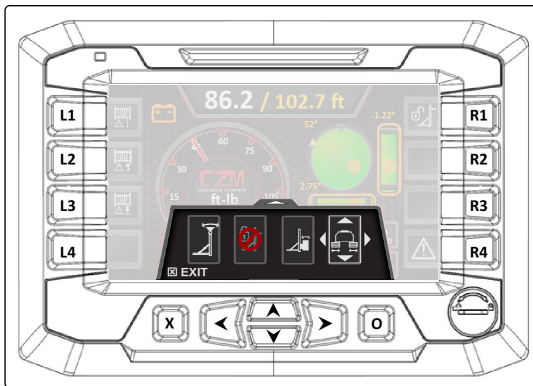

0000427 Monitor-Second Screen-Settings

- Press the left arrow button or right arrow button to highlight a function.



NOTICE

The selected function has a white outline.
It has also an up, down, left, and right arrow to select functions.

- Once a function is selected (highlighted), press the up arrow button or down arrow button to select the function to change.
A function may also be selected by touching the screen on the up arrow icon or down arrow icon next to the white outline.

Figure 125.

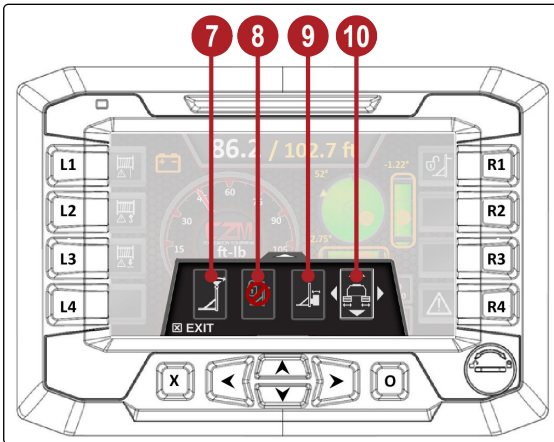

0000345 Monitor-Second Screen-Settings Elements

Table 52.

Pos.	Name	Description
7	Mast Head Fold	<p>Working Position - Press the up arrow button or touch the screen on the up arrow icon to rotate the mast head to the working position. For more information refer to Section: “Place the Mast in the Work Position” (page 298).</p> <p>Transport Position - Press the down arrow button or touch the screen on the down arrow icon. This will rotate the mast head to the transport position. For more information refer to Section: “Place the Mast in the Transport Position” (page 363).</p>
8	A-Frame Detent	<p>The A-Frame Detent is used to lock and unlock the kelly bar A-frame legs to transition between Drill and Transport modes. For more information refer to Section: “Place the Mast in the Transport Position” (page 363).</p> <p>Locked - Press the up arrow button or touch the screen on the up arrow icon.</p> <p>Unlocked - Press the down arrow button or touch the screen on the down arrow icon.</p>
9	Rotary Tilt Cylinders	<p>Working Position - Press the up arrow button or touch the screen on the up arrow icon. This will extend the rotary tilt cylinders to the working position. For more information refer to Place the Mast in the Work Position (page 298).</p> <p>Transport Position - Press the down arrow button or touch the screen on the down arrow icon. This will retract the rotary tilt cylinders to the transport position. For more information refer to Section: “Place the Mast in the Transport Position” (page 363).</p>
10	Undercarriage Position	<p>Working Position - Press the up arrow button or touch the screen on the up arrow icon to extend the undercarriage to the working position. For more information refer to Section: “Extend the Undercarriage Tracks ” (page 297).</p> <p>Transport Position - Press the down arrow button or touch the screen on the down arrow icon to retract the undercarriage to the transport position. For more information refer to Section: “Retract the Undercarriage Tracks ” (page 369).</p> <p>Press the exit button (9) to exit the setting function.</p>

6.6.8. Third Screen

The operator can adjust parameters such as:

- Main winch auto-shift.
- Main winch downshift.
- Power shift.
- Rotary auto-shift.
- Swing alarm.
- Display units.

To access the Third Screen:

1. On the Second Screen, press the right arrow.

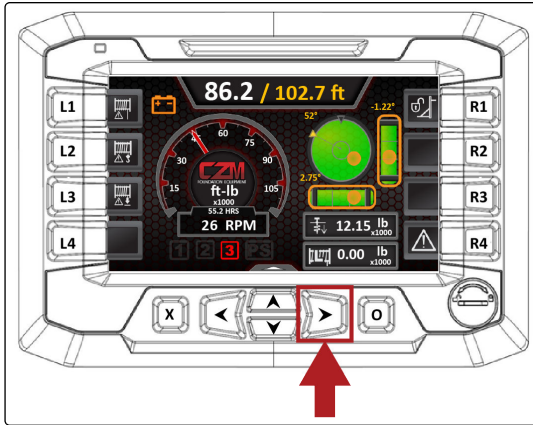

2. Page 1 of the Third Screen will appear.

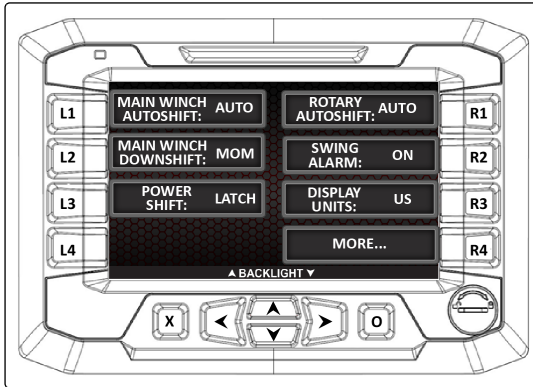

6.6.8.1. Third Screen-Page 1 Switch Functions

Switches from L1 to L4 are located on the left side of the monitor.
Switches from R1 to R4 are located on the right side of the monitor.

Figure 126.

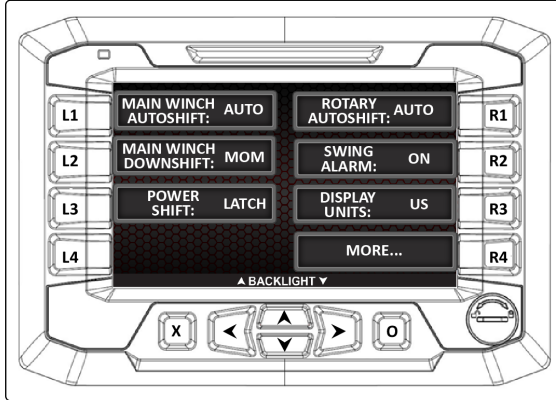

0000431 Monitor-Third Screen-Page 1

6.6.8.1.1. L1–Main Winch Auto-Shift

Press the switch to select AUTO or OFF.

AUTO: the machine will monitor the main winch pressure and automatically change the gear to High if a set point is reached, to increase the pull-up force. If the pressure decreases below the low-pressure setpoint, the machine will automatically change the gear to low to increase the speed.

6.6.8.1.2. L2–Main Winch Downshift

Press the switch to select MOM (Momentary) or LATCH.

- **MOM** : requires the operator to press and hold the switch to change the main winch gear from Low to High.
- **LATCH**: the operation will alternate between High and Low. When the main winch AUTO mode is selected, the machine will auto-shift while operating if needed.

6.6.8.1.3. L3–Power Shift

Press the switch to toggle between and select the MOM (Momentary), LATCH, or AUTO mode.

- **MOM** : the operator will press and hold the switch to keep the power shift engaged for the high-speed spin-off.
- **LATCH** : the operator press and release the switch to alternate between on or off for power shift engagement.
- **AUTO** : automatically engages power shift when the auger is above ground level and the machine swings off to the side at a setpoint degree. The power shift will automatically disengage when the auger returns to the center and underground.



NOTICE

The operator can continue to switch between on and off as needed.

6.6.8.1.4. R1–Rotary Auto-Shift

Press the switch to select ON or OFF.

ON: the machine will monitor the pressure for the rotary and will automatically downshift the rotary gear if the pressure reaches a set point to increase operating torque and prevent the rotary from stalling. The rotary gear will automatically upshift when the pressure setpoint is reached to increase the rpm as needed.

i NOTICE
The machine will only upshift to the gear selected by the operator.

6.6.8.1.5. R2–Swing Alarm

Press the switch to select ON or OFF.

ON: The machine will sound an alarm when a swing function is performed.

OFF: The alarm is muted.

6.6.8.1.6. R3–Display Units

Press the switch to select US or SI.

US: will display imperial units.

SI: will display metric units.

i NOTICE
The measurement units selected will be displayed on all monitor screens.

6.6.8.2. Third Screen-Page 2 Switch Functions

On Page 1, press the More Settings switch to access Page 2.

This screen is password protected and is accessed by entering the correct password.

The operator can access:

- Mast level calibration.
- Crowd limit override.
- Password change.
- Maintenance screen.
- Limit SW (swing) overrides mode.
- Settings.

Switches from L1 to L4 are located on the left side of the monitor.

Switches from R1 to R4 are located on the right side of the monitor.

Figure 127.

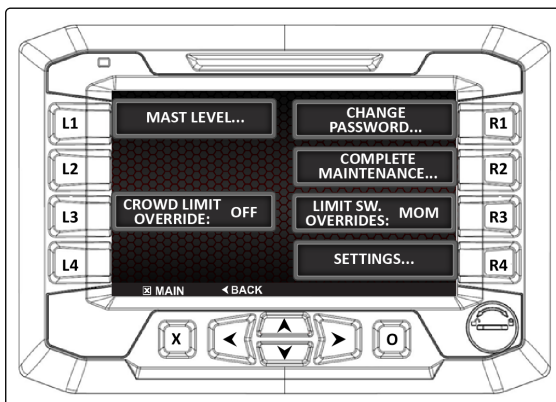

0000432 Monitor-Third Screen-Page 2

6.6.8.2.1. L1-Mast Level Calibration

Leveling the mast on the X and Y axis is adjusted on this screen.

L2-Mast Level X: Press the switch to zero the Mast Level X axis.

L3-Mast Level Y: Press the switch to zero the Mast Level Y axis.

Figure 128.

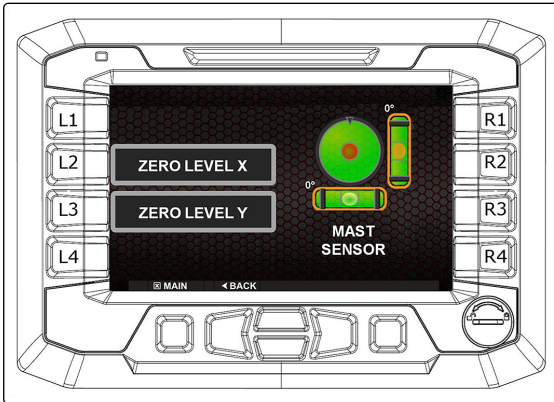

0000135-Monitor-Mast Level Calibration

6.6.8.2.2. L3–Crowd Limit Override

Press the switch to select ON or OFF.

ON: the machine will control the crowd function based on the angle the base machine is lifted and the maximum torque during operation. This will prevent the operator from overcrowding and stalling the rotary.

6.6.8.2.3. R1-Password Change

The current correct password must be entered to enter a new password.

The current password is 0000.

Figure 129.

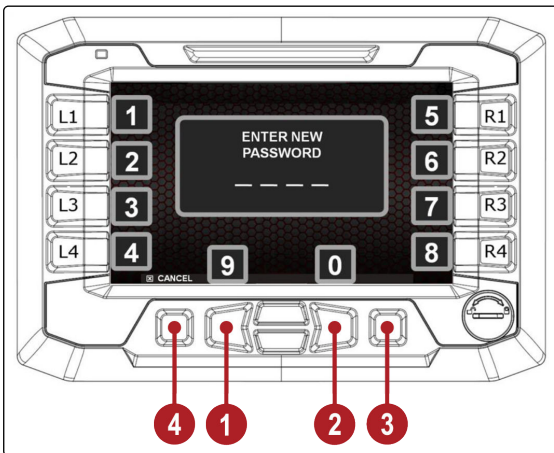

0000137 CZM Monitor-Third Screen-Password Change

To change the password, perform the following steps:

1. To select numbers 1-8, press the L1–L4 or R1–R5 switches.
 To select the number 9, press the left arrow button (1).
 To select the number 0, press the right arrow button (2).
2. Press button (3) to accept the selection.
3. Press button (4) to cancel the password change.

6.6.8.2.4. R2–Complete Maintenance

The operator will be able to access the machine maintenance schedule tasks and monitor when maintenance is required on this screen.

Maintenance reset information is also displayed.

Figure 130.

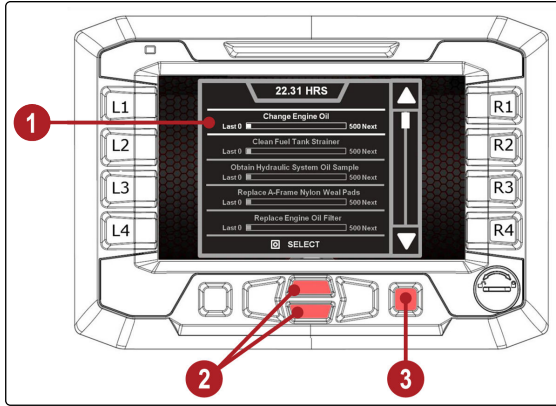

0000138 CZM Monitor-Third Screen-Maintenance List

Pos.	Function	Description
1	Status Bar	Displays the time remaining until the next maintenance task is due. When a maintenance task has been performed and confirmed by the operator, the status bar is reset to the preset interval.
2	Scroll Buttons	Press the up arrow or down arrow buttons to scroll to the desired maintenance task.
3	Selection Button	Press the button to select the desired maintenance task.

When a maintenance task is selected, the following screen is displayed.

Figure 131.

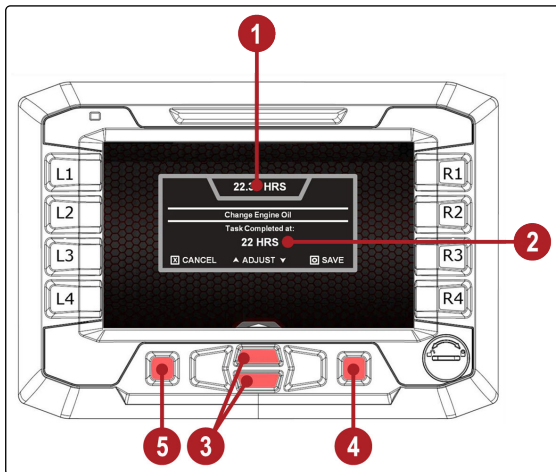

0000139 CZM Monitor-Third Screen-Maintenance Complete

Pos.	Function	Description
1	Current Hour Meter	Current hour meter reading.
2	Completion Hour meter	Hour meter reading when the selected maintenance task was completed.

Perform the following steps to confirm and update completed maintenance task times:

1. Press the up arrow or down arrow buttons (3) to adjust the time when the maintenance task was completed.
2. Press the Select button (4) to accept the setting.
3. Press the Cancel button (5) to cancel the setting change.

6.6.9. Settings Screen

Press Settings on Page 2 of the Third Screen to access the Settings Screen.

Figure 132.

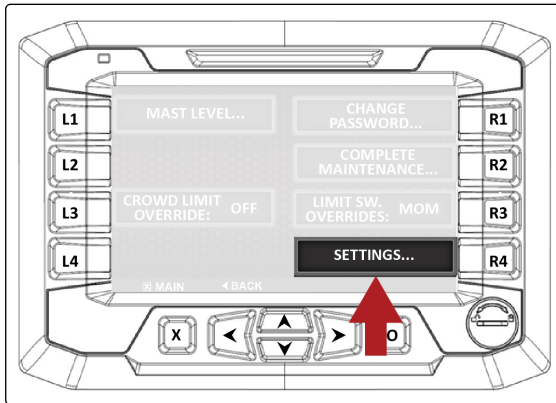

0000433 Monitor-Third Screen-Page 2-Settings Access

The following screen will appear.

Figure 133.

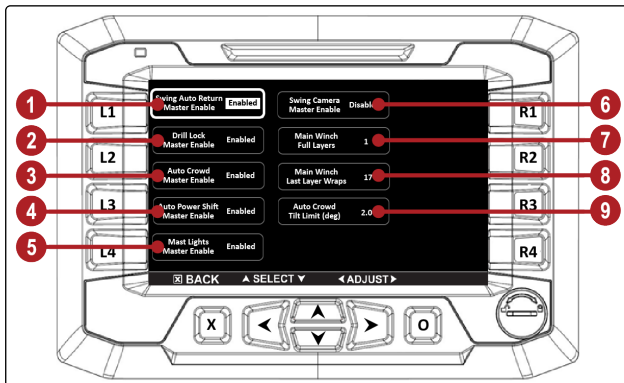

0000434 Monitor-Settings Screen Elements

Table 53.

Pos.	Name	Description
1	Swing Auto Return Master Enable	This function controls the automatic return of the machine to the hole center. Enabled or Disabled can be selected.
2	Drill Lock Master Enable	This function controls the locking function for the drilling rotation, which makes the drill lock operational. Enabled or Disabled can be selected.
3	Auto Crowd Master Enable	This function controls the automatic crowd force system to maintain a constant crowd force pressure during drilling operations. Enabled or Disabled can be selected. The auto crowd is operational when Enabled is selected.

Pos.	Name	Description
4	Auto Power Shift Master Enable	This function, if enabled, engages power shift operation automatically when the depth reading is negative (the auger is above ground level). Enabled or Disabled can be selected.
5	Mast Lights Master Enable	This function controls mast lights operation. Enabled or Disabled can be selected.
6	Swing Camera Master Enable	Enables or disables the side camera when the swing function is actuated. Enabled or Disabled can be selected.
7	Main Winch Full Layers	Displays the number of cable layers being used on the main winch drum when the kelly bar is at the limit switch stop. <div style="border: 1px solid black; border-radius: 10px; background-color: #e1f5fe; padding: 10px; margin-top: 10px;"> <p>i NOTICE This setting is important for correct depth measurement. Make sure the full layers on the drum are with the kelly bar in the full-up position.</p> </div>
8	Main Winch Last Layer Wraps	Displays the number of wraps on the last layer of the main winch drum. <div style="border: 1px solid black; border-radius: 10px; background-color: #e1f5fe; padding: 10px; margin-top: 10px;"> <p>i NOTICE This setting is important for correct depth measurement. The number of wraps on the last layer should be made with the kelly bar in the full-up position.</p> </div>
9	Auto Crowd Tilt Limit (deg)	Sets the maximum allowable angle for drilling affected by the crowd force during operation. This setting is used to prevent overcrowding. OFF or ON can be selected: <ul style="list-style-type: none"> • OFF: the machine will use the set parameter to alert the operator of overcrowding. • ON: the machine will use the set parameter to slow the crowd function and prevent overcrowding.

6.6.10. Active Faults Screens

Figure 134.

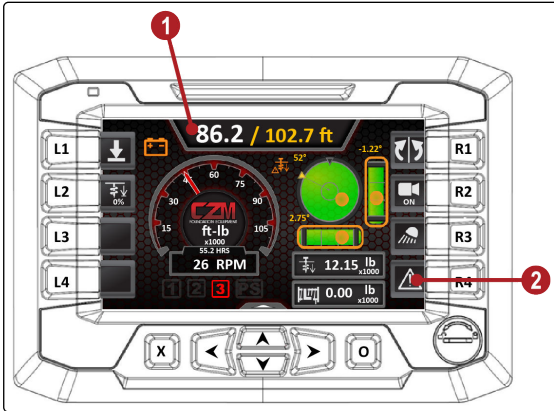

0000435 Monitor-Active Faults Screen

When there are active faults, an alert message (!FAULT!) (1) displays at the top of the main screen in place of the current/maximum drill operation depth indicators.

When this occurs, the alert icon switch (2) will flash.

Press the switch (2) to access the Active Fault Message Screen.

The faults are displayed with their fault ID number and description.

Figure 135.

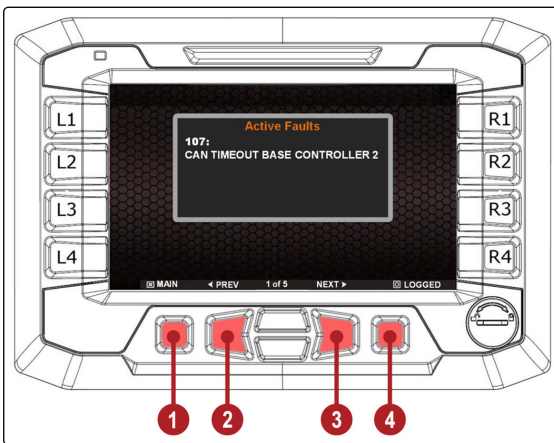

0000142 Monitor-Active Faults Message

Pos.	Function	Description
1	Main Button	Press the button to return to the main screen.
2	Prev Button	Press the button to scroll between faults displayed, if any are present.
3	Next Button	Press the button to scroll between faults displayed, if any are present.
4	Logged Button	Press the button to access the logged Active Faults Message Screen.

6.7. CAT MONITORING SYSTEM*

SMCS Code: 7451; 7490



WARNING

Do not operate the machine if the monitor is not functioning (for example, the monitor has a black screen or is not responding) when the key switch is in the ON position.

The monitor provides images from the camera system and other information for safe machine operation. Operating the machine without a properly functioning monitor may result in injury or death. If the monitor is not functioning, place the machine in a safe state by following the procedures for stopping and parking the machine. Determine the cause of the monitor malfunction and correct it before returning the machine to service.



IMPORTANT

When the monitor provides a warning, immediately check the monitor and perform the required action or maintenance as indicated by the monitor.

The monitor indicator does not guarantee that the machine is in a good condition.

Do not use the monitor panel as the only method of inspection.

Maintenance and inspection of the machine must be performed on a regular basis. See the Maintenance Section of CZM and CAT Manuals.

6.7.1. General Information*

i NOTICE
Your machine may not be equipped with all the functions described in this topic.

The monitoring system is an input and an output of the Machine Control System. The monitor has a multi-touch 8-inch or 10-inch display.

The Machine Control System communicates back and forth on the data link.

The monitoring system consists of the following components:

- Display (with numerous screens and menus)
- Indicators
- Gauges
- Soft Switch Panel
- Jog Dial

Figure 136.

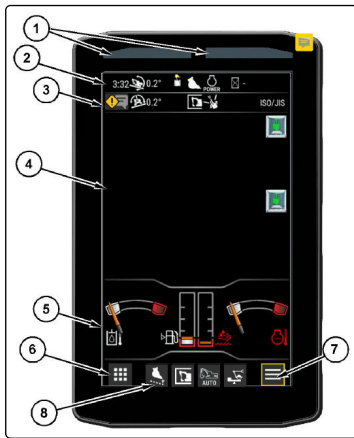

g06720205 CAT Monitor-Main Elements Description

Pos.	Description	Pg.
1	Action Lamps	234
2	Status Information Area	234
3	Notification Center Icon	236
4	Camera View Area	236
5	Gauge Area	237
6	Navigation Area	238
7	Function List	-
8	Shortcuts	-

The monitoring system displays various warnings and information about the condition of the machine, and the machines surrounding, with various camera views.

There are gauges and several alert indicators included on the monitoring system display.

Each gauge is dedicated to a parameter within a machine system.

The monitoring system will allow the user to do the following:

- View Surroundings
- Interpret status information
- Interpret parameters
- View Operation and Maintenance Manual (OMM)
- View service intervals
- Perform calibrations
- Troubleshoot machine systems

6.7.1.1. Action Lamps (1)*

The action lamps illuminate to show that a problem has occurred with the machine.

6.7.1.2. Status Information Area (2)*

Figure 137.

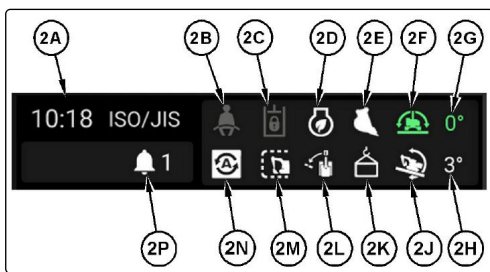

g06720245 CAT Monitor-Status Information Area

Table 54.

Pos.	Description	Pg.
2A	Multi Status Information	235
2B	Seatbelt Switch Status (if equipped)	235
2C	Hydraulic Lockout Control	-
2D	Eco Mode	-
2E	Work Tool	-
2F	XX	-
2G	XX	-
2H	XX	-
2I	XX	-
2J	XX	-
2K	Heavy Lift / Cat ® Dig Boost (if equipped)	-
2L	XX	-
2M	XX	-
2N	XX	-
2P	XX	-

Reference: For complete status information, refer to Operation and Maintenance Manual, M0109053, “Next Generation Hydraulic Excavator Monitoring System Supplement”.

6.7.1.2.1. Multi Status Information (2A)*



Service Hour Meter (2A) – Shows the total operating hours of the engine. Use the display to determine the service-hour maintenance intervals.



Soot Load (2A) – The amount of soot built up in the Diesel Particulate Filter (DPF) at the time of regeneration.



Time To Regen (2A) – Shows the estimated time left for regeneration.



Fuel Consumption Rate (2A) – Displays fuel consumption per hour. Fuel consumption can be measured in liters or gallons.



Fuel Remain Time (2A) – Shows the estimated time until fuel is empty.



Machine Rotation Angle (2A) – Indicates the rotation angle the of machine.

Tool #1 Tool name (2A) – Shows the tool name selected.



NOTICE

When the cursor is on this area, the information can be changed by touching the area or by rotating the jog dial.

6.7.1.2.2. Seatbelt Switch Status (If equipped) / Power Mode (2B)*



Not Fastened (2B) – Displays when the seatbelt is not fastened.



Smart Mode (2B) – This indicator shows that the machine is set to operate in the SMART mode.



Economy Mode (2B) – This indicator shows that the machine is set to operate in the Economy mode.



NOTICE

“ECONOMY” mode is not available on GC models.



Power Mode (2B) – This indicator shows that the machine is set to operate in the Power mode.



Disabled (2B)

6.7.1.3. Notification Center Icon (3)*

Figure 138.

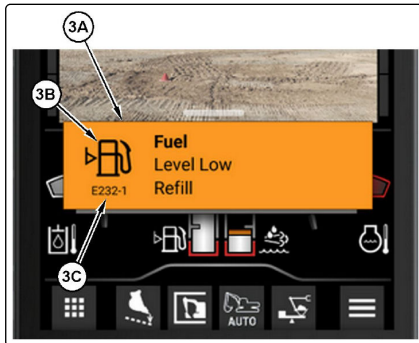

g06720210 Event Indicator Area

Pos.	Description
3A	Event Description
3B	Event Symbol
3C	Event ID

Event Description (3A) – This area will display the description of the pop-up message of the impending problem.

- Line 1: System
- Line 2: Condition
- Line 3: Action to be taken

Event Symbol (3B) – This area will display the symbol of the problem

Event ID (3C) – The identification number for the event will be shown here.

6.7.1.4. Camera View (4)*

This area on the monitor displays the view of the cameras.

A rear view camera mounted on top of the counterweight and an optional side view camera mounted in the side panel next to the hydraulic tank.

If both rear view camera and side view camera are equipped, the monitor screen can be toggled to show:

- Rear only
- Side only
- Split vertically
- Split horizontally

The camera view can be toggled when the cursor is on the camera view area and the area is touched or the jog dial is turned.

6.7.1.4.1. 360 Visibility (If Equipped)*



If equipped with the optional side and front cameras, the 360 visibility feature can be toggled on and off to enable or disable the 360-degree degree visibility view in the monitor.

Figure 139.

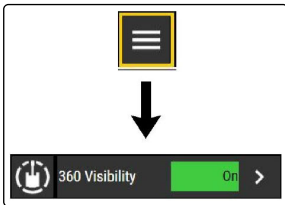

g06263096 360 Visibility

From the main screen, press the Function List icon. In the Function List menu, select “360 Visibility”.

Note: The 360 visibility system has been set up by the factory to provide views that comply with specified machine-side views. Consult CZM before any adjustments are made to the system.

6.7.1.5. Gauge Area (5)*



Fuel Level – This gauge indicates the amount of fuel that is remaining in the fuel tank. When the fuel gauge is in the red range, add fuel immediately.



Hydraulic Oil Temperature – This gauge indicates the temperature of the hydraulic oil. The normal operating range is the green range. If the gauge is in the white range, the engine and machine warm-up is required. Refer to [Engine and Machine Warm-Up* \(page 289\)](#). If the gauge reaches the red range, reduce the load on the system. If the gauge stays in the red range, stop the machine and investigate the cause of the problem.



Engine Coolant Temperature – This gauge indicates the temperature of the engine coolant. The normal operating range is the green range. If the gauge is in the white range, the engine and machine warm-up is required. Refer to Operation and Maintenance Manual, “Engine and Machine Warm-up”. If the gauge reaches the red range, stop the machine and investigate the cause of the problem.



Diesel Exhaust Fluid (DEF) Gauge (If Equipped) – This gauge indicates the level of DEF fluid in the DEF tank. When the DEF gauge is in the red range, add DEF immediately.

6.7.1.6. Navigation Bar (6)*

Apps Key – Allows you to display different information in the gauge area related to operation. Also contains air conditioner and radio controls. This key includes the settings screen allowing change of a multitude of parameters, some password protected.

Function List Key – Allows you to turn on and off various functions related to the active screen. This icon only appears in certain screens where additional settings are necessary.

Shortcuts – Allows you to set certain shortcuts on the navigation bar.

6.7.2. Machine Warnings*

Figure 140.



g06720213 Machine Warnings

Event Indicator Area

Pos.	Description	Pg.
1	Notification Center Icon	236
2	Notification Center Dashboard	-

The Monitor will display warnings, and log events for machine conditions that are not within normal operating parameters.

The event warnings are classified into three warning levels. Warning Level 1 represents the least severe problem and Warning Level 3 represents the most severe problem.

The warning levels, monitor response, and the required operator actions are given below.

Warning Level 1 (Gray) – Requires operator awareness. The icon and pop-up message will both appear gray.

Warning Level 2 (Amber) – Requires a change in the operation of the machine or a change in the maintenance of the machine to correct the condition. The icon and pop-up message will both appear amber and the action lamp will blink.

Warning Level 3 (Red) – Requires immediate shutdown of the machine to prevent damage to the machine or personnel. The icon and pop-up message will both appear red, the action lamp will blink, and the buzzer will sound. When multiple warnings are present in the system, the highest warning is shown first.

Swipe the message up or down to view all the logged warnings.

6.7.3. Logging In*

Figure 141.



g06242074 Log In

There are different ways to access the monitor which include:

- Guest access
- Passcode access
- Bluetooth access
- Cat ® Fleet Management app

For more information on logging in, refer to [Operator Login* \(page 275\)](#).

6.7.4. Navigation*

The monitor can be navigated by the touch screen or the switch panel.

Switch panel components can be used to interface with the monitor in the following ways.

Each of the buttons is also assigned a number which is imprinted in the top corner of the button.

These buttons can be used to enter the numerical passcodes used to log in to the monitor.

Figure 142.

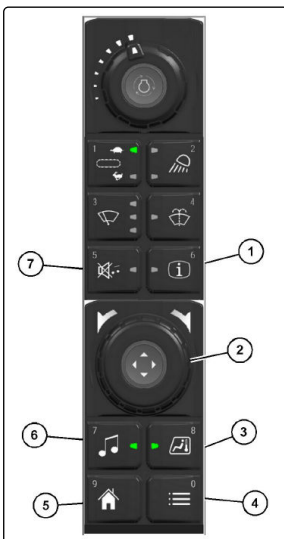

g06464384 Navigation

Pos.	Description	Pg.
1	Operator information button	240
2	Jog dial	240
3	Air conditioner button	240
4	Next menu button	240
5	Home button	240
6	Audio button	240
7	Mute button	240

6.7.4.1. Operator Information Button (1)*

Press and hold this button to access the operator information screen.
This screen shows information such as operator settings.

6.7.4.2. Jog Dial (2)*

Rotate the jog dial to highlight menu items on the monitor.
Push the jog dial down to select the highlighted item.

6.7.4.3. Air Conditioner Button (3)*

Press the button to access the air conditioner controls.

6.7.4.4. Next Menu Button (4)*

This button is equivalent to the function list key on the monitor.
This button can only be used on screens where the function list key is shown.

6.7.4.5. Home Button (5)*

Press this button to return to the main screen.

6.7.4.6. Audio Button (6)*

Press this button to access the audio controls.

6.7.4.7. Mute Button (7)*

Press this button to mute the audio.
Press the button again to unmute the audio.

6.7.5. Radio*

SMCS Code: 7338

The radio is integrated into the monitoring system.
All the radio controls are adjusted using the monitor.
The actual radio is mounted in the right rear console behind the operator seat.

Figure 143.

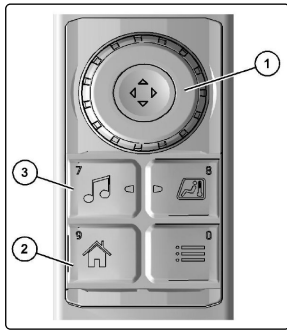

g06213193 Radio-Controls

Pos.	Description
1	Jog dial
2	Home button
3	Radio button

The audio menu can be directly accessed by pressing the radio button (3) on the right side switch panel. Input selections can be made using jog dial (1) or using the monitor touch screen. Home button (2) can be used to return to the main screen.

Figure 144.

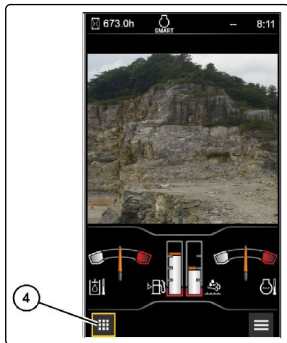

g06213076 Menu-Access Button

Press radio button (3) to go directly to the radio screen. To navigate to the radio screen from the main screen, press the application menu button (4).

Figure 145.

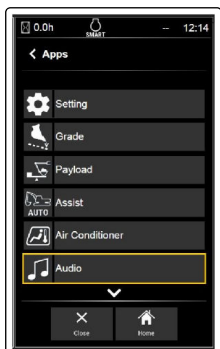

g06213198 Radio-Audio Selection

Use jog dial (1) to highlight “Audio” and then press the jog dial downward to select the entry. You may also access the screen by simply touching the “Audio” box on the touch screen.

Figure 146.

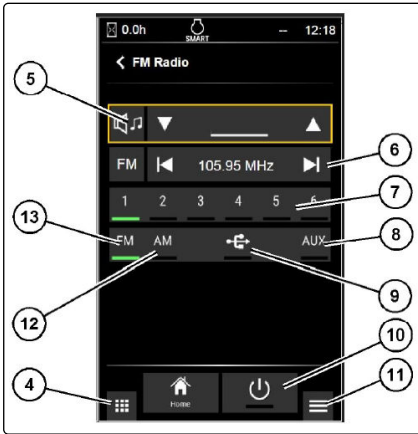

g06213200 Radio Screen

Pos.	Name	Description
4	Application menu button	Use this button to return to the application menu.
5	Volume control	The volume control is used to raise or lower the audio volume.
6	Tuner	The tuner is used to tune the radio to the desired station.
7	Preset stations	The preset stations store favorite radio stations for the operator. To set a station, tune to the desired station. Press and hold the preset number you want to assign to that station. Once a beep is heard, release the button. The indicator light for the active Preset station will illuminate.
8	Auxiliary button	When a device is plugged into the auxiliary port, press the auxiliary button to connect the device to the radio. The indicator light will illuminate when this mode is active.
9	USB button	When a device is plugged into the USB port, press the USB button to connect the device to the radio. The indicator light will illuminate when this mode is active.
10	Power button	Pressing this button turns the radio on and off. The indicator light on the monitor and on button (3) will illuminate when the power is on.
11	Radio Function List menu	Pressing this button leads to the radio function list menu.
12	AM button	Press this button to access AM radio. The indicator light will illuminate when this mode is active.
13	FM button	Press this button to access FM radio. The indicator light will illuminate when this mode is active.

6.7.5.1. Radio Function List*

To access the radio function list, press the function list button (11) in the lower right corner of the radio screen.

Figure 147.

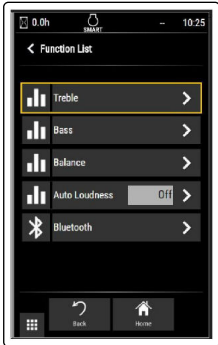

g06223378 Radio Function List

The function list menu consists of the following items:

Treble – Allows the user to adjust the treble.

Bass – Allows the user to adjust the bass.

Balance – Allows the user to adjust the balance between speakers.

Auto Loudness – When on, this feature automatically adjusts treble and bass levels when reducing the volume setting. This effect allows the user to hear more clearly at a lower volume.

Bluetooth – Allows the user to pair a phone, view paired devices, and edit device names.

6.7.5.2. Selection Method*

All settings can be made using the touch screen or by using the jog dial.

The method depends on the preference of the operator.

When using the touch screen, simply touch the icon you want to select.

When using the jog dial, rotate the dial to switch to different selections within the screen.

Press the jog dial downward to choose a selection.

Figure 148.

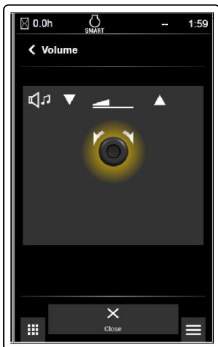

g06213233 Radio Selection Method

When using the jog dial to set the volume or tuner, rotate the dial clockwise to increase and counterclockwise to decrease.

Press downward on the dial to enter the desired setting.

6.7.5.3. Radio Operation*

1. To operate the system, press power button (10).
2. Select between the AM button for AM stations or select the FM button for FM stations.
3. Use tuner (6) to adjust to the desired station. If presets stations (7) are set, press the desired preset station.
4. Use volume control (5) to adjust the volume.
5. When the machine is in operation turn down the volume of the radio.

6.7.5.4. USB/AUX Operation*

Figure 149.

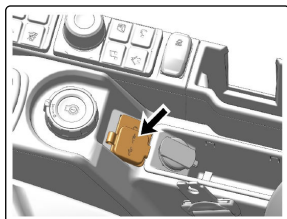

g06213245 USB AUX

1. To play audio from a device such as an MP3 player or a phone connect the device using an auxiliary cable or a USB cable. Depending on the cable being used, plug the cable into the appropriate port on the console.
2. Select either USB or AUX depending on which type of cable was used. Play the music from the device. The music should be playing over the radio speakers if properly connected. Adjust the volume as necessary.

Figure 150.

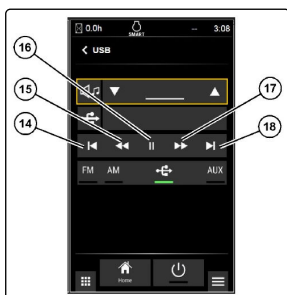

g06213254 USB Controls

Note: If USB is selected, extra controls appear on the screen for playing music. They include the following.

- 14 – Skip to the beginning of the track
- 15 – Rewind the track
- 16 – Pause/Play the track
- 17 – Fast forward the track
- 18 – Skip to the end of the track

6.7.6. Air Conditioning and Heating Control*

SMCS Code: 7304; 7320; 7337

Consult with CZM for periodic maintenance of the heating and air conditioning system.

Figure 151.

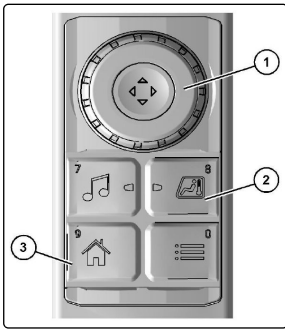

g06178710 Air Conditioning and Heating-Controls

Pos.	Description
1	Jog dial
2	Heating and air conditioning button
3	Home button

Air conditioning and heating functions are controlled through the monitor. The heating and cooling menu can be directly accessed by pressing button (2) on the right side switch panel. Input selections can be made using jog dial (1) or using the monitor touch screen. Home button (3) can be used to return to the main screen.

Figure 152.

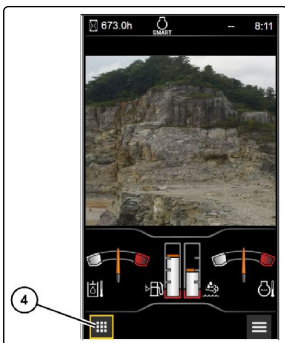

g06213076 Menu-Access Button

Press the Air Conditioning and Heating button (2) to go directly to the air conditioner screen. To navigate to the air conditioner screen from the main screen, press application menu button (4).

Figure 153.

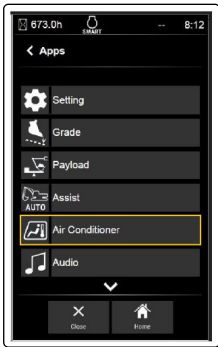

g06213088 Air Conditioning and Heating-Button

Use jog dial (1) to highlight “Air Conditioner” and then press the jog dial downward to select the entry. You may also access the screen by simply touching the “Air Conditioner” box on the touch screen.

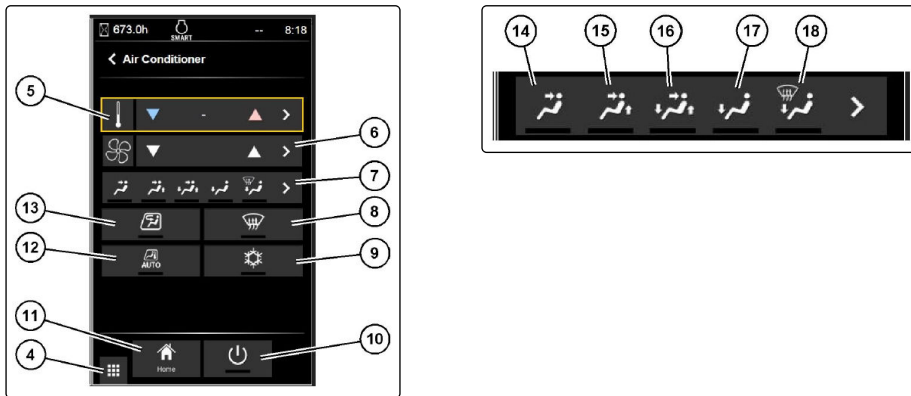

Air Conditioning and Heating-Screen

Pos.	Name	Description
4	Application menu button	Use this button to return to the application menu.
5	Temperature control	The temperature control is used to raise or lower the desired temperature.
6	Fan blower speed control	The blower control is used to increase or decrease the desired blower speed.
7	Air outlet settings	The desired air outlet setting can be chosen from this panel. The indicator light will illuminate to show the active setting.
8	Defroster	Pressing this button activates and deactivates the defroster. Use the defroster to remove steam and frost from the windows. The indicator light will illuminate when this mode is active.
9	Compressor ON/OFF	Pressing this button activates and deactivates the air conditioner. The indicator light will illuminate when this mode is active.

Pos.	Name	Description
10	Power	Pressing this button turns the heating and cooling system on and off. Push and hold the power button for 3 seconds to turn OFF the HVAC system. The indicator light on the monitor and on button (2) will turn green when power is on.
11	Home button	Use this button to return to the main screen.
12	Auto	Select this option to hold the system at the desired temperature. The system will modulate to keep the cab at the temperature that the system is set to. The indicator light will illuminate when this mode is active.
13	Recirculation	This option recirculates air from the cab instead of pulling air from the outside. This mode is more efficient because the system is recycling conditioned air from the cab. However, no fresh air is coming into the cab when in this mode. The indicator light will illuminate when this mode is active.
14	Front vents	In this mode, air will only circulate from the front vents.
15	Front and rear vents	In this mode, air will circulate from the front vents and rear vents.
16	Front, foot, and rear vents	In this mode, air will circulate from the front vents, rear vents, and foot vents.
17	Foot vents	In this mode, air will only circulate from the foot vents.
18	Defrost and foot mode	In defrost mode, air will circulate from the front vents and foot vents.

6.7.6.1. Selection Method*

All settings can be made using the touch screen or by using the jog dial. The method depends on the preference of the operator.

When using the touch screen, simply touch the icon you want to select.

When using the jog dial, rotate the dial to switch to different selections within the screen.

Press the jog dial downward to choose a selection.

Figure 154.

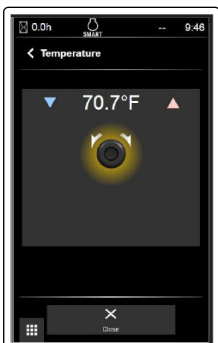

g06213141 Air Conditioning and Heating-Temperature Set

When using the jog dial to set the temperature or blower speed, rotate the dial clockwise to increase and counter-clockwise to decrease.

Press downward on the dial to enter the desired setting.

6.7.6.2. Operation*

To operate the system:

1. Press power button (10).
2. Use temperature control (5) to adjust to the desired temperature.
3. Select the desired mode and outlet vents.
4. Use fan blower speed control (6) to adjust the blower. If the system is in “Auto” mode, the blower fan speed and air outlet setting will automatically be adjusted. But recirculation air intake is not changed automatically.

Note: in cold ambient temperature condition, fan speed is stopped or restricted depend on coolant temperature.

Figure 155.

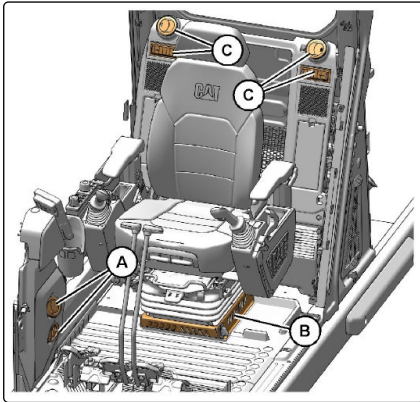

g06178705 Air Conditioning and Heating-Vents1

Pos.	Description
A	Defrost vent (front window)
B	Foot air vents
C	Rear air vents

Figure 156.

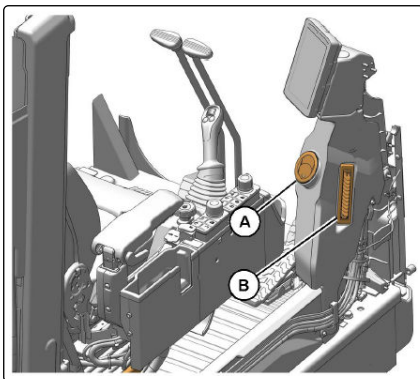

g06287632 Air Conditioning and Heating-Vents2

Pos.	Description
A	Front vent
B	Defrost vent (RH window)

7. OPERATION

7.1. BEFORE OPERATION



WARNING

Before operating the drilling rig, review all the safety precautions described in [Section: "Safety" \(page 65\)](#).

7.1.1. Daily Inspections

Perform prestart inspections:

- Check the engine oil level, coolant fluid level, DEF level, fuel level, and hydraulic oil level.
- Inspect the hydraulic system for leaks. Inspect the tank, cylinder rod seals, hoses, tubes, plugs, connections, and fittings. Correct any leaks in the hydraulic system.
- Inspect the tubes and hoses along the boom/articulation and stick for wear and leaks. Replace any hoses or tubes that are worn or leak.
- Inspect the final drives for leaks. Make any necessary repairs.
- Inspect the swing drive for leaks.
- Inspect wire ropes for visible wear or damage.
- Inspect the undercarriage, parallelogram, and mast for any damage, cracks, or loose and missing hardware.
- Inspect all limit switches or proximities.
- Inspect pin connections between crowd cylinders and the rotary (if present).
- Inspect the mast articulation pin and safety pin.
- Inspect the A-frame pins and safety pins.
- Inspect the counterweight bolts (if present).
- Inspect the steps, the walkways, and the handholds. Clean the steps, the walkways, and the handholds. Make any necessary repairs.
- Inspect the operator cab for trash buildup. Check for trash buildup under the floorplate and on the crankcase guard. Keep these areas clean.
- Adjust the mirrors to achieve the best visibility. Refer to [Mirrors* \(page 255\)](#).

7.1.2. Mounting and Dismounting

For mounting and dismounting the drilling rig correctly, refer to [Access to the Drilling Rig \(page 100\)](#).

7.1.3. Cab Operation

7.1.3.1. Cab Door*

SMCS Code: 7308

Figure 157.



g06180275 Cab Door-External Handle

To open the cab door from the outside of the cab, pull outward on the door handle.

Figure 158.

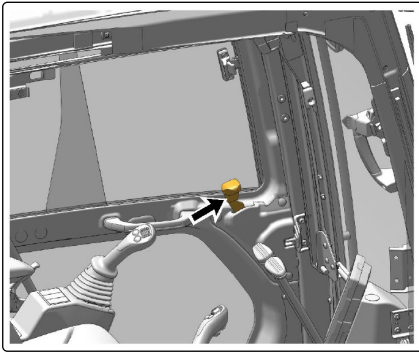

g06179959 Cab Door-Inside Handle

To open the cab door while inside the cab, push forward on the lever for the cab door latch. For additional ventilation, open the cab door all the way to engage the catch on the exterior wall of the cab.

Figure 159.

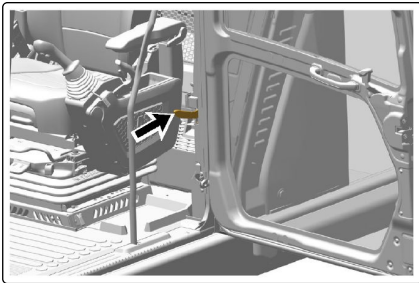

g06180267 Cab Door-Catch

To release the cab door from the catch, pull downward on the cab door release lever.

Figure 160.

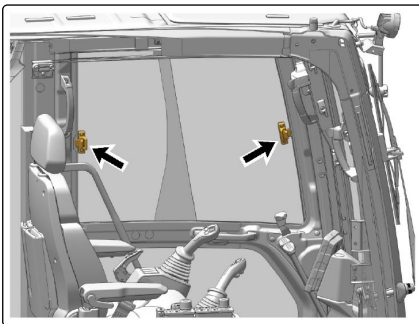

g06179957 Cab Door-Window

To open a window, release the window latch, and then slide the window to the desired position.

7.1.3.2. Window (Front)*

To provide full ventilation inside the cab, the upper window and the lower window can be fully opened.



WARNING

When opening or closing the windows, be extra careful to prevent any personal injury. The hydraulic lockout control must be in the LOCKED position to prevent any possibility of sudden movement of the machine due to inadvertent contact with the hydraulic control(s).

Do not change the position of the window until the following items have been done:

- Park the machine on a level surface.
- Lower the work tool to the ground.
- Move the hydraulic lockout control to the LOCKED position.
- Stop the engine.

Perform these steps to open the upper window.

Figure 161.

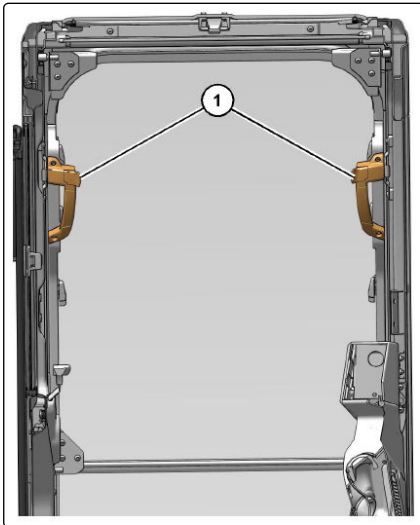

g06185052 Cab-Front Window Levers

1. Release the auto-lock latches by pressing release levers (1) on the window handles.
2. Holding both handles on the window frame, pull the window upward.
3. Hold both grips that are provided on the window frame and move the window into the storage position until the auto-lock latches near the ceiling are engaged.

Once opened, perform these steps to close the upper window.

1. Release the auto-lock latches by pressing release levers (1) on the window handles.
2. Reverse Steps 1 through 3 to close the upper window.

Perform these Steps to open the lower window and close the lower window.



NOTICE

The lower window is curved. The lower window can only be positioned one way in the holders.

1. Raise the lower window out of the window frame.

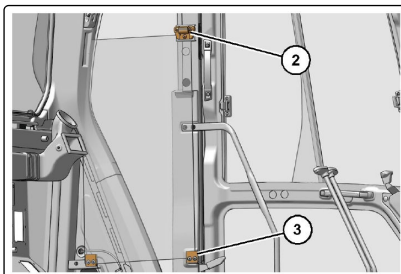

2. Store the lower window in the holder that is located in the rear of the left side cab frame. To store the lower window, locate one end of the lower window into brackets (3). Secure the opposite end of the lower window with catch (2).
3. To close the lower window, reverse the procedure that is used for opening the lower window.

7.1.3.3. Roof Hatch*

! WARNING
 When opening or closing the windows, be extra careful to prevent any personal injury. The hydraulic lockout control must be in the LOCKED position to prevent any possibility of sudden movement of the machine due to inadvertent contact with the hydraulic control(s).

! IMPORTANT
 Do not change the position of the roof hatch without performing the following actions:

- Park the machine on a level surface.
- Lower the work tool to the ground.
- Move the hydraulic lockout control to the LOCKED position.
- Stop the engine.

Figure 162.

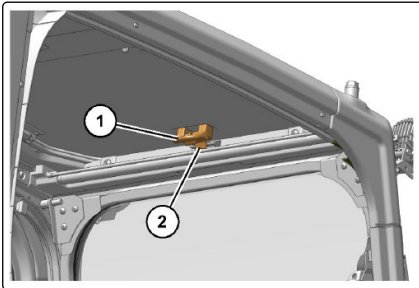

g06179871 Cab-Roof Hatch

Pos.	Description
1	Grip
2	Lock

To open the roof hatch, release lock (2). Hold grip (1) and push the roof hatch upward.
 To close the roof hatch, hold grip (1) and pull the roof hatch downward. Engage lock (2) securely.

! CAUTION
 Do not stand or walk on the hatch or the roof of the cab. Serious damage may occur.

7.1.3.4. Sun Screen*

! WARNING
 When opening or closing the windows, be extra careful to prevent any personal injury. The hydraulic lockout control must be in the LOCKED position to prevent any possibility of sudden movement of the machine due to inadvertent contact with the hydraulic control(s).

**NOTICE**

Do not change the position of the sun screen without performing the following actions:

- Park the machine on a level surface.
- Lower the work tool to the ground.
- Move the hydraulic lockout control to the LOCKED position.
- Stop the engine.

Do not use the sun screen when opening the front window.

Figure 163.

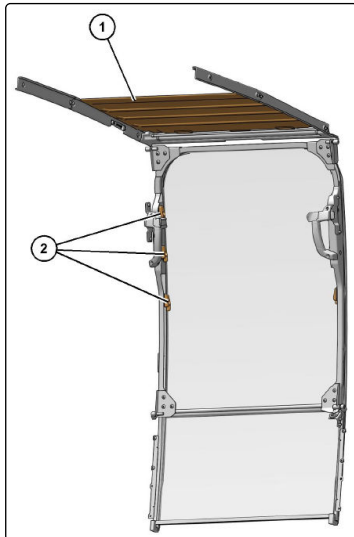

g06179846 Window-Sun Screen

1. Pull sun screen (1) down from the ceiling.
2. Hook the sun screen to the brackets (2) at both sides of the front window.
3. The sun screen may be positioned at two different heights.

7.1.3.5. Dome Light*

Figure 164.

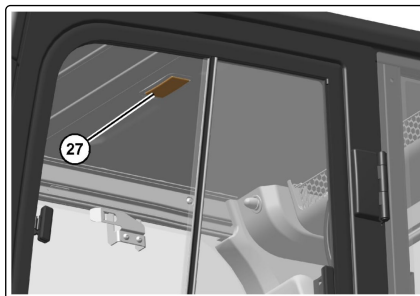

g06208645 Cab-Dome Light

The dome light (27) has three different positions.

1. When the dome light is in the center position (horizontal), the light will come on when the door is open and shut off when the door is closed.
2. When the left side of the light is pressed, the lamp will be inoperable.

3. When the right side of the light is pressed, the lamp will be illuminated until the lamp is switched to another position.

7.1.4. Visibility

! WARNING
 Before starting the machine, check that you have the correct visibility around the machine.
 Failure to follow this warning could result in death or serious injury.

7.1.4.1. Mirrors*

! WARNING
 Adjust all mirrors as specified in the Operation and Maintenance Manual.
 Failure to follow this warning could result in death or serious injury.

Note: Your machine may not be equipped with all the mirrors that are described in this topic.

Figure 165.

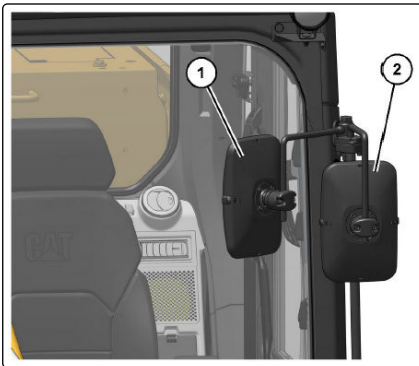

g06220616 Mirrors-Cab Right and Left Side View

Table 55.

Pos.	Description
1	Right Side View Mirror on the Cab
2	Left Side View Mirror on the Cab

Figure 166.

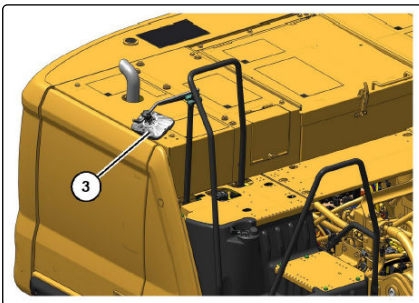

g06220627 Mirrors-Tank

Table 56.

Pos.	Description
3	Tank Mirror

Mirrors provide additional visibility around your machine. Make sure that the mirrors are in proper working condition and that the mirrors are clean. Adjust all mirrors at the beginning of each work period and adjust the mirrors when you change operators.

Modified machines or machines that have additional equipment or attachments may influence your visibility.

7.1.4.1.1. Mirror Adjustment*

- Park the machine on a level surface.
- Lower the work tool to the ground.
- Move the hydraulic lockout control to the LOCKED position. For further details on this procedure, refer to [Section: "Hydraulic Lockout Control"](#) (page 195).
- Stop the engine.
- Adjust rear view mirrors to provide visibility behind the machine at a maximum distance of 30 m (98 ft) from the rear corners of the machine.

Figure 167.

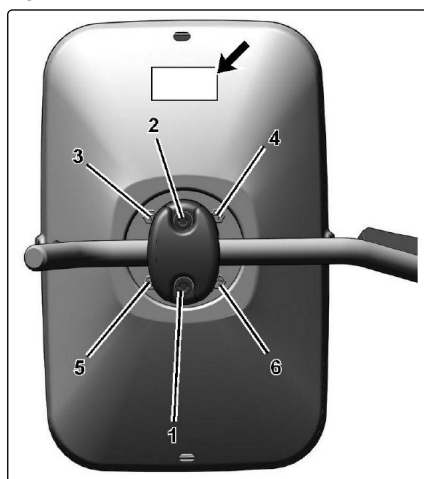

g06220634 Mirrors-Tightening Sequence

After adjustment of the mirror angle, make sure that the CAT logo is at the top.

It may be necessary to periodically tighten the mirror mounting bolts.

If the bolts are loose, tighten the bolts in the sequence shown in [Figure 167](#).

Tighten bolts (1) and (2) to 11 ± 2 N·m (8.1 ± 1.5 lb ft). Tighten the bolts (3) through (6) to 2 ± 0.4 N·m (1.5 ± 0.3 lb ft).

7.1.4.1.1.1. Right Side View Mirror on the Cab (1)*

Figure 168.



g06223277 Mirrors-Right Side View Mirror on the Cab

If equipped, adjust the right side view mirror on the cab (1) so the front of the right track can be seen from the operator's seat.

A view of at least 1 m (3.3 ft) from the right front of the machine should be seen from the operator's seat.

7.1.4.1.1.2. Left Side View Mirror on the Cab (4)*

Figure 169.



g06223279 Mirrors-Left Side View Mirror on the Cab

If equipped, adjust the left side view mirror on the cab (4) so the left side of the cab, access door, and rear of left track can be seen from the operator's seat.

A view of at least 1 m (3.3 ft) from the side of the machine should be seen from the operator's seat.

Additionally, provide as much visibility to the rear as possible.

7.1.4.1.1.3. Tank Mirror (3)*

Figure 170.

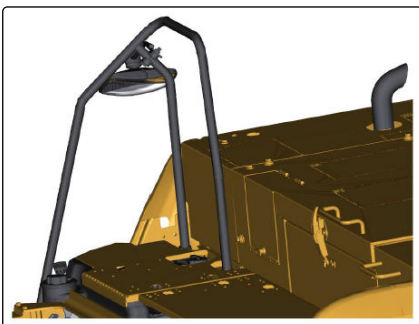

g06223284 Mirrors-Tank View

If equipped, adjust the tank mirror so the fuel tank and the hydraulic tank can be seen from the operator's seat. A view of at least 1 m (3.3 ft) from the side of the machine should be seen from the operator's seat.

7.1.4.2. Cameras*

7.1.4.2.1. Rear View Camera*

Figure 171.



g06184579 Camera-Rear View Camera

The rear view camera system consists of a camera that is located in the middle of the top of the counterweight.

Note: The camera system has been set up by the factory or by a Cat dealer to provide views that comply with specified guidelines. Consult your Cat dealer before any adjustments are made to the system.

For more information refer to [Section: "CAT Monitoring System*" \(page 232\)](#)

7.1.4.2.2. Right Side View Camera (If Equipped)*

Figure 172.



g06214504 Camera-Side View Camera

The side view camera system consists of a camera mounted on the panel next to the pump compartment.

Note: The camera system has been set up by the factory or by a Cat dealer to provide views that comply with specified guidelines. Consult your Cat dealer before any adjustments are made to the system.

For more information refer to [Section: "CAT Monitoring System*" \(page 232\)](#)

7.1.4.2.3. 360 Visibility (If Equipped)*

Figure 173.

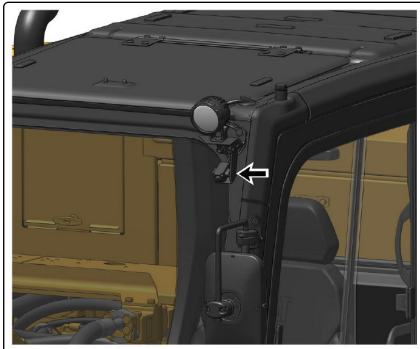

g06263449 Camera-360 Visibility-Front

Figure 174.

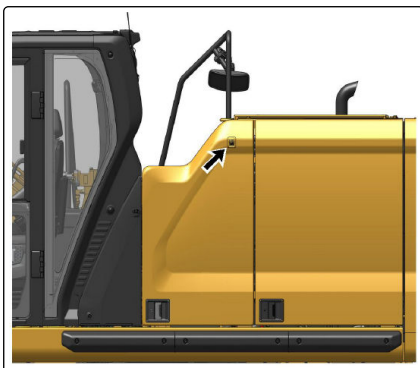

g06263435 Camera-360 Visibility-Left Side

The 360 visibility system consists of a front camera and a left-side camera in addition to the right-side and rear view cameras.

If equipped with the optional side and front cameras, the 360 visibility feature can be toggled on and off to enable or disable the 360-degree visibility view in the monitor.

Figure 175.

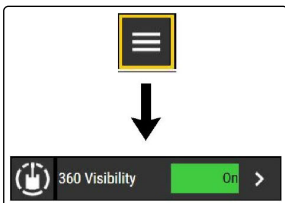

g06263096 360 Visibility

From the main screen, press the Function List icon.

In the Function List menu, select "360 Visibility".

Note: The camera system has been set up by the factory or by a Cat dealer to provide views that comply with specified guidelines. Consult your Cat dealer before any adjustments are made to the system.

For more information refer to [Section: "CAT Monitoring System*" \(page 232\)](#)

7.1.5. Fuel Transfer Pump (Refueling) (If Equipped)*

SMCS Code: 1256

Use the following procedure to pump fuel and store the hose.

Figure 176.

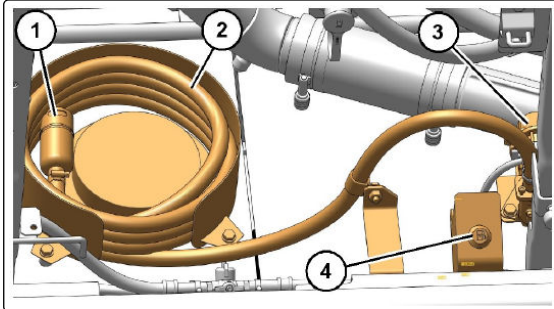

g06180565 Fuel Transfer Pump System

Pos.	Description
1	Suction valve
2	Suction hose
3	Electric refueling pump
4	ON/OFF switch



ON/OFF Switch – Push the ON/OFF switch to activate or deactivate the fuel transfer pump. A red indicator on the switch will illuminate when the fuel transfer pump is activated.

If one of the following conditions occur, the fuel transfer pump will not activate and/or stop operating:

- Battery disconnect switch is in the OFF position.
- Engine is operating.
- Engine start switch is moved to the START position.
- Engine start switch is in the OFF position.
- Hydraulic lockout control is not in the LOCKED position.
- Fuel tank level is full.
- Fuel is not detected at the suction valve.
- 30 seconds following detection of no fuel at the suction valve.

Use the following procedure to pump fuel and store the hose:

1. Park the machine on a level surface. Move the hydraulic lockout control to the LOCKED position. Stop the engine.
2. Turn the engine start switch to the ON position without starting the engine.
3. Remove the fuel tank cap from the fuel tank.
4. Open the access that is on the right side of the machine. Suction valve (1) is at the end of hose (2).
5. Uncoil the hose and turn the end of the suction valve clockwise to open the suction valve.

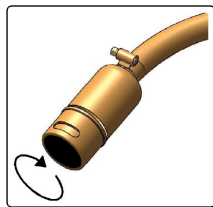

6. Properly insert the end of the suction valve into a container of fuel.
7. Push switch (4) to activate the fuel transfer pump and supply the fuel to the tank. A red indicator on the switch will illuminate when the fuel transfer pump is activated.

When the fuel tank is full, the fuel transfer pump will automatically stop.

When the fuel container is empty, push the switch again to stop refueling. If additional fuel is needed, wait 30 seconds and return to step 6.

Note: The red indicator on the switch will no longer illuminate when the fuel transfer pump has stopped refueling.

Note: The fuel transfer pump will not activate for 30 seconds following a detection of no fuel at the suction valve.

8. Push the switch at any time to deactivate the fuel transfer pump.

Note: The red indicator on the switch will no longer illuminate when the fuel transfer pump has stopped refueling.
9. Drain excess fuel from the hose and turn the end of the suction valve counter-clockwise to close the suction valve.
10. Wind the hose and store in the hose container.



IMPORTANT

To prevent hose damage, do not coil the hose in a tight radius.

11. Close the access door.
12. Install the fuel tank cap onto the fuel tank.
13. Turn the engine start switch to the OFF position.

7.1.5.1. Fuel Tank Shutoff and Drain Control*

SMCS Code: 1273

Fuel Tank Drain Valve

The drain valve for the fuel tank is located in the right compartment.

- To drain the water and sediment from the fuel tank, turn the fuel drain valve counterclockwise.
- To close the fuel tank drain valve, turn the drain valve clockwise.

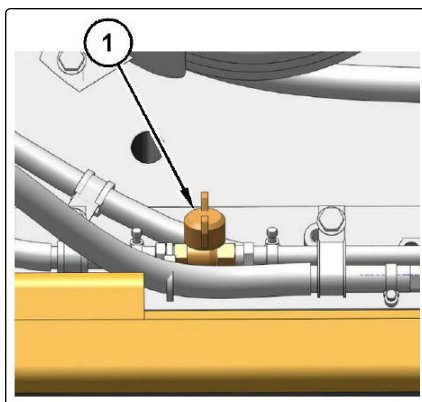

Fuel Shutoff Valve

The fuel shutoff valve is located behind the right access door.

- To shut off the fuel supply, turn the fuel shutoff valve clockwise.
- To turn on the fuel supply, turn the fuel shutoff valve counterclockwise.

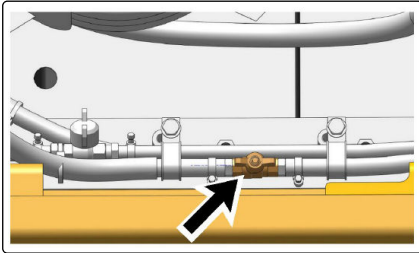

Note: For more detailed information that pertains to draining the water and sediment from the fuel tank, refer to [Draining the Fuel Tank Water and Sediment*](#) (page 442).

7.1.6. Operation Information*

Make sure that no personnel is on the machine or near the machine to prevent any personal injury. Keep the machine under control at all times to prevent injury.

1. Adjust the operator seat.
2. Fasten the seat belt.
3. Turn the engine speed dial to the desired operating range.



4. Move the hydraulic lockout control to the UNLOCKED position.

7.1.6.1. Undercarriage

7.1.6.1.1. Traveling

- Sound the horn and allow adequate time for bystanders to clear the area before moving the machine into a restricted visibility area. Follow local practices for your machine application. For more information, refer to [Danger Zones](#) (page 164).
- Allow the engine and hydraulic oil to warm up before moving the machine.
- Select the necessary travel speed range before you drive downgrade. Do not change the travel speed range while you drive downhill.
- Use the same travel speed on a downgrade and on an upgrade.
- Undercarriage tracks must be fully extended.
- Do not swing the upperstructure while traveling.
- Watch the clearance of the mast. Uneven ground can cause the machine to bounce.
- Rotary, work tool and mast must be in the lowest horizontal position when traveling.
- Do not travel with the mast tilted.
- Do not move the mast while traveling.
- Do not travel with a suspended load.
- Avoid sudden movements.

- Before traveling consult the *Section: “Stability and Ground Pressure ” (page 139)*.
- Clear all personnel and obstacles from the machine's path.
- Ask for the help of a ground assistant.
- Make sure all cab and compartment doors are closed and secured.
- Be sure that all windows are clean and secured.
- Adjust mirrors as required for best visibility.
- Fasten the seat belt.

**IMPORTANT**

Before moving the machine, check the position of the undercarriage. The normal travel position is with the idler wheels to the front under the cab and the drive sprockets to the rear. When the undercarriage is in the reversed position, the directional controls must be operated in opposite directions.

7.1.6.2. Base Swinging**DANGER**

Failure to follow these instructions will cause serious injury or death.

- Make sure that the area is clear of personnel and equipment.
- Swing the base slowly and smoothly.
- Swing the base only with the mast in the vertical position.
- Do not swing the base with the mast in the horizontal position.
- Do not lower the mast while the base is swung.
- Do not swing the base if the counterweight is disassembled.
- Do not swing the base if the track is not extended.
- Only swing the base with the track extended.

7.1.6.3. Parallelogram**DANGER**

Improper use could result in a tip over.

- Move the parallelogram slowly and smoothly.
- Only use the parallelogram movements to:
 - Position the mast correctly on the hole.
 - Place the machine in working or transport configuration.
- Do not use the parallelogram to exert a crowd or pull-up force on the tool.
- While the parallelogram is moving, always check the winches' ropes' tension.

7.1.6.4. Winches**DANGER**

Failure to follow these instructions will cause serious injury or death.

**DANGER**

Improper use could result in a tip over.

The use of damaged ropes is very dangerous.

To avoid accidents:

- Inspect the ropes according to the instructions in this manual.
- Replace the ropes if damaged or worn.

- Check that ropes' assembly and fastening are carried out correctly.
- Check that the winding and unwinding of the rope on the drum take place regularly and without slackening. Looseness can cause damage to the rope.

7.1.6.4.1. Main Winch

**DANGER**

Failure to follow these instructions will cause serious injury or death.

**DANGER**

Improper use could result in a tip over.

- Use the main winch only to raise and lower the drilling equipment inside the hole.
- Use the main winch only to raise and lower the drilling equipment along the vertical axis.

7.1.6.4.2. Auxiliary Winch

**DANGER**

Failure to follow these instructions will cause serious injury or death.

**DANGER**

Improper use could result in a tip over.

Before using the auxiliary winch:

- Make sure you have read and understood what is written in:
 - [Auxiliary Winch \(page 50\)](#)
 - [Auxiliary Winch \(page 105\)](#)
 - [Auxiliary Winch \(page 174\)](#)

7.2. STARTING THE MACHINE

7.2.1. Selective Catalytic Reduction Warning System*

SMCS Code: 1091-WXX; 7400

The selective catalytic reduction (SCR) system is a system used to reduce NOx emissions from the engine. Diesel exhaust fluid (DEF) is pumped from the DEF tank and is sprayed into the exhaust stream. The DEF reacts with the SCR catalyst to reduce NOx and leaves nitrogen and water vapor. The Exhaust Gas Recirculation (EGR) system cools, measures, and introduces recalculated exhaust gas into the intake manifold to aid in NOx reduction.



IMPORTANT

Stopping the engine immediately after the engine has been working under load can result in overheating of SCR components.

Refer to [Section: "Stopping the Engine*" \(page 315\)](#) procedure to allow the engine to cool and to prevent excessive temperatures in the turbocharger housing and the DEF injector.

Note: With the operator key in the OFF position, the purge system will activate.

7.2.1.1. Definitions*

Observe the following definitions.

Self-correct – Fault condition no longer exists. An active fault code will no longer be active.

Notification – Action taken by the system to alert the operator of pending Inducement.

Inducement – Engine derates, vehicle speed limits, or other actions intended to prompt the operator to repair or maintain the emission control system.

Inducement Trigger – Fault conditions that result in activation of the inducement strategy. DEF level inducement faults have a diagnostic fault code. DEF quality fault, SCR tampering fault, SCR system fault, and EGR system faults will all have a related diagnostic fault code along with an inducement diagnostic fault code.

First occurrence – A DEF quality fault, SCR tampering fault, SCR system fault, or an EGR system fault becomes active for the first time.

Repeat occurrence – If any DEF quality fault, SCR tampering fault, SCR system fault, or an EGR system fault becomes active again within 40 hours of the first occurrence.

Safe Harbor Mode – Safe harbor mode is a 20 minute engine run time period. The engine can be operated with full power after reaching a level 3 inducement. Once in level 3 inducement, the operator can perform a key cycle and the engine will enter safe harbor mode. Safe harbor mode can only be implemented once. Safe harbor mode is not allowed for DEF level inducements.

Figure 177.

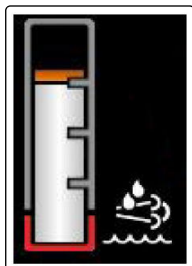

g06223861 DEF Level Normal

7.2.1.2. Inducement Strategy for DEF Level*

If multiple warnings are present in the system, the most important problem is shown first. Press the right key or press the left key to view all the warnings that are present in the machine. If no keys are pressed within 5 seconds, the display will return to the most important problem.

Figure 178.

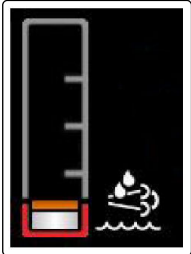

g06223864 DEF Level Low

If the DEF level falls below 19%, “DEF Level Low” message will be displayed on the monitor. To avoid further inducements, turn the key to the OFF position and add DEF to the DEF tank.

Figure 179.

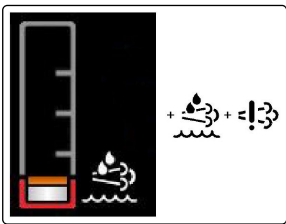

g06223865 DEF Level Low and Emission Fault

If the DEF level falls below 12.5%, a level 1 inducement event will occur. a “DEF Level Low” message and an “Emission Fault” message will appear on the monitor.

Figure 180.

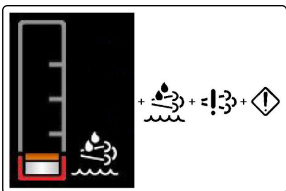

g06223866 DEF Level Low, Emission Fault, and Flashing Action Lamp

If the DEF level is below 6%, a level 2 inducement event will occur. a “DEF Level Low” message and an “Emission Fault” message will appear on the monitor. The action lamp on the monitor will flash. If the ECM is configured to “Reduced Performance” and the DEF level has reached 0%, the machine will be limited to 75% torque.

Figure 181.

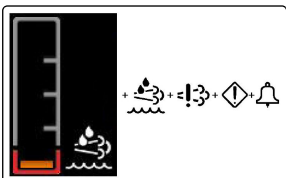

g06223883 DEF Level Low, Emission Fault, Flashing Action Lamp, and Audible Alarm

If the ECM is configured to “Reduced Performance” and the DEF tank has been emptied of all DEF, the engine will be in a level 3 final inducement. If the ECM is configured to “Reduced Time” and the DEF level is 0%, the engine will be in a level 3 final inducement. Prior to final inducement a “DEF Level Low” message, and an “Emission Fault” message will appear on the monitor. The action lamp on the monitor will flash and an audible alarm will sound 20 seconds prior to the final inducement. The engine will be taken to low idle or will be shut down. Once shut down, the engine can be restarted for 5 minute periods at reduced speed and torque. If set to idle, the engine will idle indefinitely at reduced torque. The amber indicator next to the DEF level gauge on the dash will remain lit.

Note: Turn the key to the OFF position and add DEF to the DEF tank to reset the DEF level inducement.

7.2.1.3. Inducement Strategy for DEF Quality, Tampering, SCR System Fault, and Impeded EGR*

If multiple warnings are present in the system, the most important problem is shown first. Press the right key or press the left key to view all the warnings that are present in the machine. If no keys are pressed within 5 seconds, the display will return to the most important problem.

Figure 182.

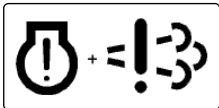

g03623190 Engine Fault Check Engine+Emission Fault

A “Engine Fault Check Engine” message and an “Emission Fault” message will appear on the monitor for a fault resulting from poor DEF quality, SCR system tampering, SCR system fault, or an EGR system fault. If the fault is the result of poor DEF quality, SCR system tampering, or SCR system fault, a first occurrence will result in a level 1 inducement for a duration of 2.5 hours. The level 1 inducement will also illuminate the check engine lamp. Repeat occurrences will result in a level 1 inducement duration of 5 minutes. If the fault is the result of an EGR system fault, a first occurrence will result in a level 1 inducement for a duration of 35 hours. Repeat occurrences will result in a level 1 inducement duration of 48 minutes.

Figure 183.

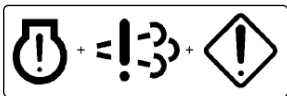

g03623191 Engine Fault Check Engine+Emission Fault+Flashing Action Lamp

If a fault condition exists for the entire duration of inducement level 1, the strategy advances to inducement level 2. A “Engine Fault Check Engine” message, and an “Emission Fault” message will appear on the monitor and the action lamp on the monitor will flash for a fault resulting from poor DEF quality, SCR system tampering, SCR system fault, or an EGR system fault. For poor DEF quality, SCR system tampering, and SCR system faults, the duration for a level 2 inducement is 70 minutes for the first occurrence. For EGR system faults, the duration for a level 2 inducement is 60 minutes for the first occurrence. Repeat occurrences for poor DEF quality, SCR system tampering, and SCR system faults will result in a level 2 inducement of 5 minutes. Repeat occurrences for EGR system faults will result in a level 2 inducement of 60 minutes.

Figure 184.

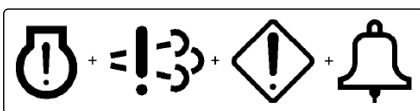

g03623193 Engine Fault Check Engine+Emission Fault+Flashing Action Lamp+Audible Alarm

If a fault condition exists for the entire duration of inducement level 2, the strategy advances to inducement level 3. A “Engine Fault Check Engine” message, and an “Emission Fault” message will appear on the monitor, the action lamp will flash, and an audible alarm will sound 20 seconds prior to the level 3 inducement. The engine will be taken to low idle or will be shut down. After the level 3 inducement you may cycle the key, which will allow 20 minutes of engine run time with full torque. After 20 minutes, the engine will be in level 3 final inducement and will allow idle only or be shut down until the issue has been resolved. Once shut down, the engine can be restarted for 5 minute periods at reduced speed and torque. If set to idle, the engine will idle indefinitely at reduced torque.

Note: Contact your Cat dealer for repairs if a fault occurs.

7.2.2. Machine Security System*

SMCS Code: 7631

7.2.2.1. General Information*



IMPORTANT

This machine may be equipped with a Cat ® Machine Security System (MSS) and may not start under certain conditions.

Figure 185.



g06223917 MSS-Symbol

Machines that are equipped with Cat MSS can be identified by a decal in the operator station. Read the following information and know your machine settings. Your Cat dealer can identify your machine settings.

The Cat Machine Security System (MSS) discourages unwanted operation of a machine. When armed, the MSS requires the operator's login to start the engine. The following methods of operator login to disarm the security system are available:

- Cat Bluetooth® key fob
- Cat App: Fleet Management
- Passcode

Figure 186.

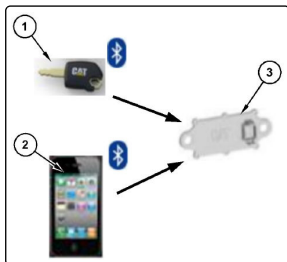

g06212167 MSS-Bluetooth Connections

Pos.	Description
1	Cat Bluetooth key fob (CATBTFOB)
2	Smartphone application
3	Cat Bluetooth transceiver (CATBTNT)

The Cat Bluetooth key fob (1) contains an electronic chip. The electronic chip has a unique identification number (ID). A Bluetooth transceiver is mounted in the cab to read the ID of the key. The Bluetooth transceiver module translates the information received from the key fob into a J1939 message. This message is sent to the Electronic Control Module (ECM) that is connected to the MSS. The ECM is typically the Machine ECM. The ECM is set up with the ID of the keys of the intended users.

When the MSS is armed, the ECM validates the ID of the key fob. If the key ID is on the list of authorized keys in the ECM and the key is valid, the machine will operate normally. If the key ID is not on the list of authorized keys in the ECM or is not valid, the MSS will keep the critical machine functions disabled.

Note: A Bluetooth enabled phone can disarm MSS if the phone is on the list. Operator Management System (OMS) is necessary to be able to add phones to the vehicle ID list. After the phone is added, OMS is no longer needed for the Cat App: Fleet management mobile application to function as a valid key. If the MSS is not installed, the operator can skip the login and the machine will operate normally.

7.2.2.2. Components*

The Machine Security System (MSS) consists of the following components:

- Electronic Control Module (ECM)
- Cat Bluetooth key fob (CATBTFOB)
- Machine display
- Bluetooth transceiver module (CATBTNT)
- Engine start switch

7.2.2.3. System Overview*

The Machine Security System (MSS) is designed to restrict operation of a machine. A list of the authorized electronic keys and passcodes for a machine is contained in the ECM for the MSS. A valid Bluetooth key fob, mobile application, or passcode can disarm the MSS. If the MSS is disabled or not installed, any operator may access critical machine functions.

The Cat® Electronic Technician (Cat ET) Service Tool can be used to program the ECM with the authorized keys and passcodes. Bluetooth devices and passcodes can be registered using the in-cab display if the operator is logged in to the system using a master access account.

When the engine start switch is turned to the ON position, the display boots up. If Bluetooth detection is enabled, the transceiver will receive a signal from any Bluetooth key that is present or from the mobile application. The ECM will then compare this ID to the list of authorized keys.

Note: If multiple devices are present, the first valid device detected by the transceiver will be read.

If the ID of the key matches an authorized key, the status indicator on the engine start switch will turn a green color and the MSS will disarm. This disarming will allow the operator access to critical functions of the machine.

If the ID of the key that is read does not match the list in the ECM, the status indicator will remain a red color. The MSS remains in the “armed” state and the machine will remain disabled.

If the MSS is disabled and the ID of the key matches an authorized key, the operator will be identified and allowed access to the critical machine functions. The operator will be able to save configurations and start the machine.

If the MSS is disabled and the ID of the key that is read does not match an authorized key, the operator must log in as a guest. The operator will not be able to save custom configurations but will have access to starting the engine.

7.2.2.4. Activating Bluetooth Functionality*

For shipping purposes, Bluetooth functionality is deactivated.

Ensure that Bluetooth functionality is active on your machine using the following procedure:

- Ensure that the function is active from the radio screen:
 - a. From the home screen, press the navigation button in the lower left corner, then select “Audio”.

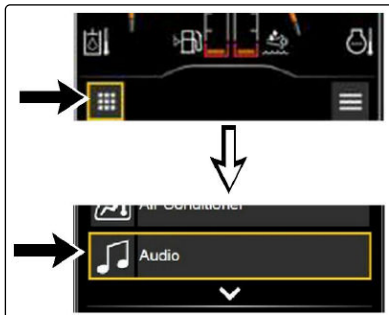

- b. Press the radio function list menu button in the lower right corner, then select “Bluetooth”. Ensure that “Bluetooth” is set to “ON”.

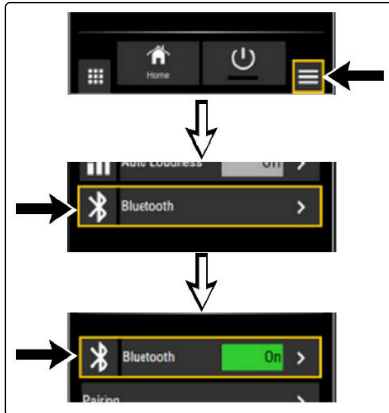

7.2.2.5. Pairing Your Device to the Machine*

Use the following procedure to pair your device to the machine:

1. From the home screen, press the navigation button in the lower left corner, then select “Audio”.

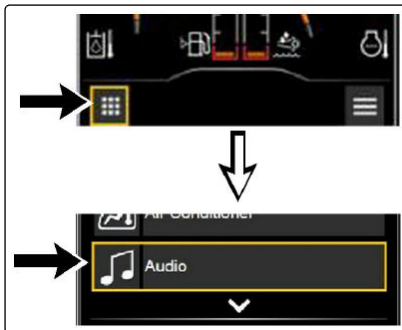

2. Press the radio function list menu button in the lower right corner, then select “Bluetooth”.

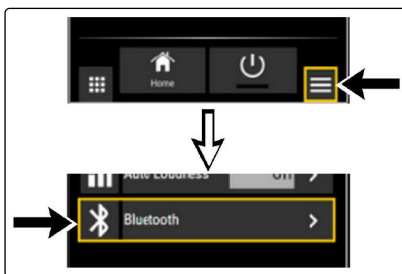

3. Select “Pairing”, then “Device Name”.

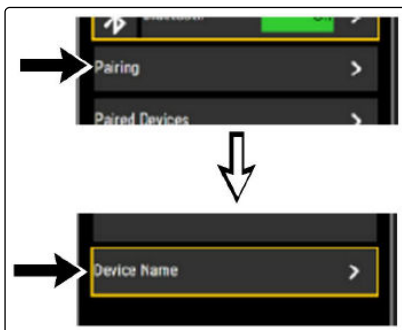

4. Find your device on the list and pair the devices. Ensure that the devices are paired on your phone as well.

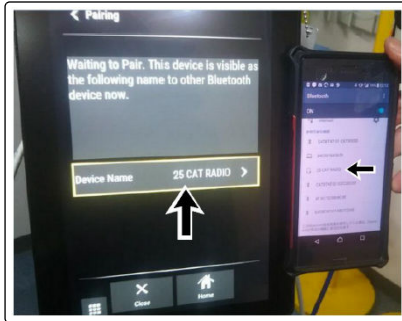

Note: The device name on your phone should be “##CAT RADIO”, with the number being from “00” to “99”.

7.2.2.6. Reading the ID of a Key*

The Machine Security System (MSS) must identify a valid passcode, Bluetooth key fob ID, or Cat ® myEquipment mobile application ID.

When the engine start switch ring is turned to the ON position, the MSS will check the ID of any key fob or mobile application. If the ID matches a key ID stored in the machine ECM, the critical ECM functions are enabled. An enable message is also sent via the Cat ® data link or J1939 data link to the other ECMs on the machine. The machine will operate normally.

Note: If the machine ECM has failed or has been removed, the critical machine operations controlled by the other electronic control modules will not operate.

7.2.2.7. Armed*

When the MSS is armed, critical machine functions are disabled. The MSS disables the power that is supplied to each component that is powered by the output drivers. The machine will not be able to operate normally.

There are two states of operation within the “armed” mode:

- **Engine Start Switch Ring Position OFF** – When no power is applied to the MSS, the MSS will default to “armed” state. When power is applied to the MSS and the grace period has expired, the MSS will return to the “MSS Armed”.
- **Engine Start Ring Switch Position ON** – When the engine start switch ring is first moved to the ON position, the display boots up and the system attempts to detect a Bluetooth key ID or mobile application ID. The ECM will continue reading until a valid key ID is read or passcode is entered. If a valid key ID or passcode is not read, the MSS status indicator will remain red and the MSS remains armed.

7.2.2.8. Disarmed*

When the MSS is disarmed, normal machine operation is allowed. A message is sent to the other machine ECMs over the Cat data link. or J1939 data link. The machine will be able to start. The green LED on the status indicator will illuminate.

There are multiple ways to disarm the machine:

- Use a valid passcode
- Use a valid Bluetooth key fob
- Use the Cat ® myEquipment mobile application
- Use the Cat Electronic Technician (Cat ET) Service Tool to configure the MSS bypass schedule to allow machine operations during scheduled periods of time during the week.

7.2.2.9. Grace Period*

After a machine has been started successfully, the operator will have a grace period after the machine is turned off before the MSS is automatically armed. The operator is not required to arm the system manually.

During the grace period, an operator can start the machine without a key ID or passcode. When the grace period expires, the MSS will rearm automatically.

If the MSS is unable to read a key ID, the system will remain armed. When the MSS identifies a key with an invalid key ID, the system will remain armed.

The grace period for a machine can be configured with Cat ET if a factory password or master level account is available.

7.2.2.10. Navigating the User Interface Touchscreen Display*

Figure 187.

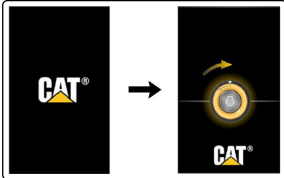

g06210561 MSS-Startup Sequence Screens

The display will start up automatically after turning the battery disconnect switch to the ON position. The screen will prompt the operator to turn the engine start ring to the ON position. When the engine start ring is turned to the ON position, the display will navigate to the passcode entry screen.

If the operator has not turned the engine start ring to the ON position, the display will time out after 1 minute.

If the battery disconnect switch is already on and the display is off, the display will startup automatically after the engine start ring is powered on. The Cat screen will appear for a short time and then login keypad will appear.

Note: Avoid touching the screen with sharp objects.

The access level assigned to the operator can limit or expand the amount of freedom the user has to manage the system. The following paragraphs explain access levels.

There are three levels of operator access recognized by the touchscreen display. The following levels are available:

- Guest
- Standard
- Master

Guest – If an operator does not have an authenticated key or passcode, the user is able to bypass log in as a guest. Some menu features will not be available such as the options for saving configurations and operator management. If the Machine Security System (MSS) is enabled, guest operators cannot start the machine.

Standard – A standard operator is a registered user of the machine. Operators with this access level can start the engine whether or not the MSS is installed. This user may save a control configuration for future applications.

Master – Master accounts can perform operator management in addition to all standard-level functions.

Any “Standard” or “Master” account may be created or removed by a “Master” level operator.

Selections and Access for the Touchscreen Display	
Access Level	Operator Setting
Guest	“Operator Input Configuration” “Response” “Change Operator”
Standard	“Operator Input Configuration” “Response” “Controls Setup” “Change Operator”
Master	“Operator Input Configuration” “Response” “Controls Setup” “Change Operator” “Manage Operator”

7.2.2.11. Operation of Status Indicator*

Figure 188.



g06215426 MSS-Engine Start Switch with Integrated MSS Indicator

The Machine Security System (MSS) uses a status indicator that is integrated into the engine start switch in the cab. This indicator provides a visible alert for the security system.

The operator can use the status indicator to determine the status of the system or for troubleshooting.

Figure 189.



g06226442 MSS-Engine Start Switch MSS Armed

When the MSS is armed, the status indicator will be red. The red light warns the operator that the machine is armed with the security system and that an operator login is required. The red LED will remain ON until a valid key is read while the key switch or engine start switch ring is in the ON position.

Figure 190.



g06226444 MSS-Engine Start Switch MSS Disarmed or Uninstalled

When the MSS is disarmed, the status indicator will be green. The green light notifies the operator that an operator is logged on the machine and the security system has been disarmed. The status indicator will be green if the MSS is not installed on the machine. Also, the green LED will remain ON after powering down for the duration of the grace period. After the grace period, the MSS automatically returns to the “armed” mode.

For machines with a standard key switch, a separate status indicator will be available.

7.2.2.12. Operator Login*

Any user may start the engine if the Machine Security System (MSS) is disabled.

If the MSS is active, only a “Standard” or “Master” account can start the machine engine. Before starting the machine engine, the security system must identify a registered operator. An operator can access the machine display using one of the following methods:

- Passcode
- Cat Bluetooth key
- Cat App: Fleet Management

7.2.2.12.1. Passcode Entry*

To log in using a passcode, refer to the following steps:

Figure 191.

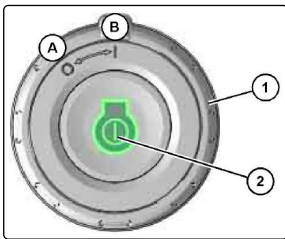

g06180554 Engine Start Switch

Pos.	Description
A	Off
B	On
1	Engine start ring
2	Start button

1. Turn engine start switch (1) to the ON position (B).
2. Enter a registered passcode using the monitor keypad and then press “Enter”.

Note: The jog dial or the numbered buttons on the right-side switch panel can also be used to enter the code.



3. Select “Enter” to confirm the passcode. If a registered passcode is recognized, the operator information screen will appear on the display. If the MSS is not installed, the passcode screen will be bypassed automatically after 10 seconds. The operator will be logged in to the system as a guest. Refer to Illustration.



4. Select “OK” to continue to the display home screen.
5. After an operator logs in to the system successfully, an “Engine Start Allowed” message will appear across the top of the monitor. Refer to [Section: “Engine Starting*” \(page 286\)](#) for instructions on starting the engine.

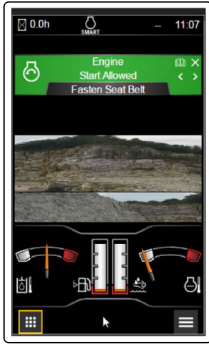

7.2.2.12.1.1. Invalid Passcode*

Figure 192.



g06209472 MSS-Invalid Passcode Screen

If a passcode is not recognized, the display will notify the user with an “Invalid code” message. Refer to Illustration. The operator has five tries to enter a valid passcode successfully. After a fifth unsuccessful attempt, a lockout screen will appear and remain on the display for a duration of 5 minutes.

Note: If the Machine Security System (MSS) is not active, the user can select the “Skip Login” button to avoid the lockout period.

For more information refer to [Section: “Bypass Login*” \(page 277\)](#).

7.2.2.12.1.2. Bypass Login*

Operator login can be bypassed if the user selects the “Skip Login” button on the display. The operator will be logged in to the machine with “Guest” level access.

If the MSS is inactive, the operator will be able to start the engine as normal and view all display screens.

If the MSS is active on the machine, the operator is able to view all display screens but will not have access to starting the engine.

7.2.2.12.2. Bluetooth Entry*

Alternatively, a Bluetooth Operator ID can be used to log in to the machine. For a Bluetooth key to be detected by the system, ensure that the following qualifications are met:

- The key must be registered with the machine
- The key must be within the cab
- Bluetooth setting must be enabled on the display

Refer to the following steps when logging in to a machine using the Bluetooth key:

Figure 193.

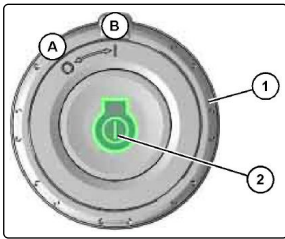

g06180554 Engine Start Switch

Pos.	Description
A	Off
B	On
1	Engine start ring
2	Start button

1. Turn engine start switch (1) to the ON position (B).
2. Wait several seconds for the system to detect the key when the passcode dialog appears. Once the key is detected, the “Operator Information” screen will display.
3. Select the “OK” button if the proper operator has been displayed.

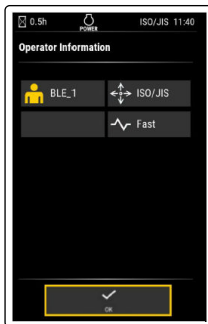

4. After an operator logs in to the system successfully, an “Engine Start Allowed” message will appear across the top of the monitor. Refer to [Engine Starting* \(page 286\)](#) for instructions on starting the engine.

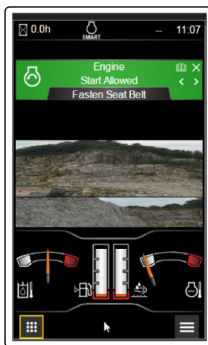



IMPORTANT

The access level will change to a “Guest” account automatically if the key is removed from the cab at any time.

If the MSS is enabled and the engine is on when the key is removed from the cab, the operator will not be able to start the engine if turned off.

To turn on the engine again without the Bluetooth key, the operator will need to log in a registered account using either the smartphone application or passcode.

Note: If multiple Bluetooth devices are within the cab, the system will select the first device detected by the Bluetooth transceiver as the active operator.

7.2.2.12.3. Cat ®Fleet Management Mobile Application*

Operators can also log in to a machine using the Cat App: Fleet management mobile application. For the application to be detected by the system, ensure that the following qualifications are met:

- The Mobile Device ID (MDID) of the mobile application must be assigned to the machine in the Operator Management System (OMS)

Note: It is not possible to assign mobile devices through the MSS interface.

- The mobile device must be within the cab
- “Operator Management Bluetooth Device Enabled Status” is enabled (Cat ET Configuration)

Note: For adding an operator, adding MDID to the machine key list, and pushing the machine key list from the OMS to the machine refer to the OMS documentation at:

<https://myoperators.cat.com/>

7.2.2.12.3.1. Mobile Device/Operating Software Compatibility*

Table 57. Mobile Device/Operating Software Compatibility

Make	Model	Operating Software
Android	Varies	Android 8.x Oreo and up (Preferably Android 9.x Pie)
Apple	iPhone 6/ iPhone 6 Plus and up	iOS 11.0 and up (Preferably 12)

Note: Android mobile hardware support for Bluetooth can vary, so it is possible that a mobile device running Android 8.x software or higher could have hardware that does not support Bluetooth 4.1.

7.2.2.12.3.2. Mobile Application Entry (Android Devices)*

To log in using the Cat App: Fleet management mobile application, refer to the following steps:

Figure 194.

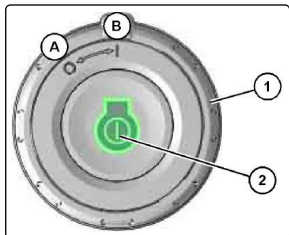

g06180554 Engine Start Switch

Pos.	Description
A	Off
B	On
1	Engine start ring
2	Start button

1. Turn engine start switch (1) to the ON position (B).
2. Open the Cat App: Fleet management mobile application on the mobile device.



3. Click "I Agree" to agree with the End-User License Agreement and sign in with Cat eCustomer account credentials.

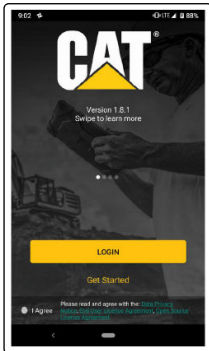

Note: If you do not have a Cat eCustomer account, click "Get Started" to create one.

4. Select "Login".
5. Enter Cat eCustomer account credentials.

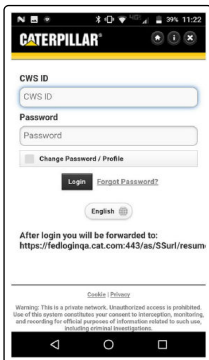

6. Click "Allow" to enable the Cat App: Fleet management mobile application to work as designed.
Note: Cat App: Fleet management requires access to the mobile device location to use Bluetooth radio to connect to Cat machines.

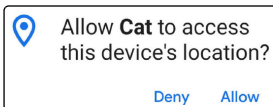

7. Upon login, the Cat App: Fleet management mobile application will open onto the equipment tab.
Note: The "Equipment" tab will be empty on the first login.

The Menu Icon (1) includes “Preferences”, “Notifications and Alerts”, along with various documents covering the end-user license agreement, and privacy notice.

By tapping the Map Icon (2), the operator will be able to see the location of each vehicle on their “Equipment” tab on a map.

If a vehicle is not equipped with a telematics device, or the vehicle is a non-caterpillar machine it may be necessary to add it manually using the Add Equipment Icon (3).

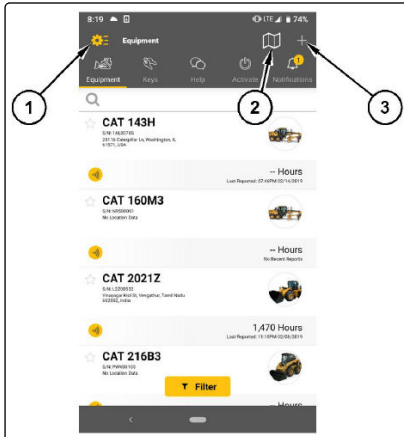

8. Go to the keys tab.

Keys are necessary to connect to vehicles. If no keys are given, the screen in Illustration 424 will be displayed. The MDID is necessary to assign keys to the user account. The MDID of Android devices is linked to the app.

Note: Uninstalling the Cat App: Fleet management mobile application will result in the MDID and keys being deleted. The Sim card of the phone contains the MDID information, damage to the Sim card may result in keys being lost, if the phone is replaced transfer the Sim card to avoid key loss.

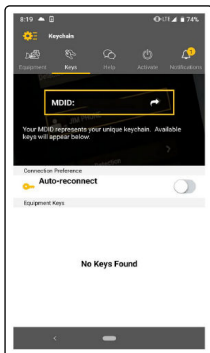

9. Pull the “Equipment Keys” down to refresh the list once the Fleet/Key configuration process has finished. Wait up to 30 seconds until the keys populate. If the keys do not populate, check that the MDID is correct and that the list was pushed properly through OMS.

10. Ensure that the machine is ON to connect to a machine.

The machine display should prompt the operator for a password. In the “Keys” tab in the Cat App: Fleet management mobile application and tap the key that matches the machine. If a vehicle is OFF, currently occupied, or too far away the key will be grayed out and say “Out of range” .

Note: If the machine has a user signed in that is not in the cab and it has become necessary for a different user to operate the machine, change the operator in the operator setting.

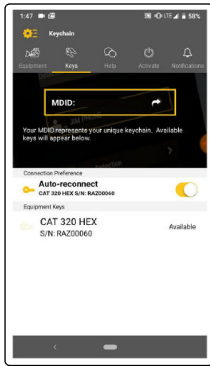

11. Access the “Equipment” tab by tapping it. The machines associated with the keys should have populated. To learn more about a machine, tap it.

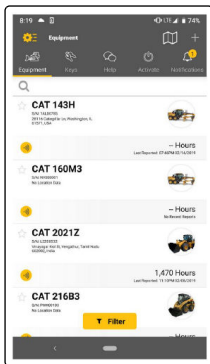

12. Press the “Disconnect” button if the user wishes to disconnect. If the user wants to switch machines, tap the arrow in the upper left then tap the machine the operator wants to be switched to.

Note: Disconnect from vehicles if the user is not going to be using a vehicle again within a short time.

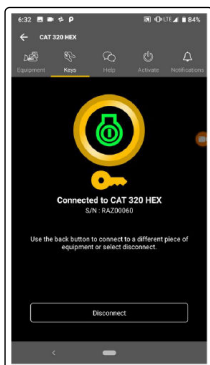

13. After an operator logs in to the system successfully, an “Engine Start Allowed” message will appear across the top of the monitor. Refer to [Engine Starting* \(page 286\)](#) for instructions on starting the engine.

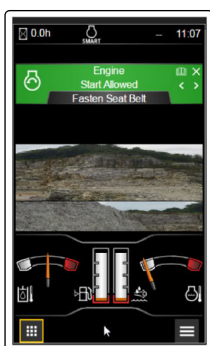

7.2.2.12.3.3. Mobile Application Entry (iOS Devices)*

Figure 195.

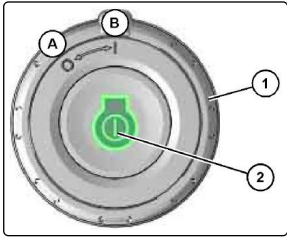

g06180554 Engine Start Switch

Pos.	Description
A	Off
B	On
1	Engine start ring
2	Start button

1. Turn engine start switch (1) to the ON position (B).
2. Ensure that Bluetooth detection is enabled on the in-cab display.
3. Open the Cat App: Fleet management mobile application on the mobile device.



4. Click "I Agree" to agree with the End-User License Agreement and sign in with Cat eCustomer account credentials.

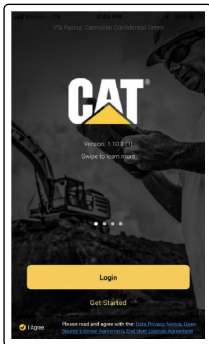

Note: If you do not have a Cat eCustomer account, click "Get Started" to create one.

5. Select "Login".
6. Enter Cat eCustomer account credentials.



- Upon login, the Cat App: Fleet management mobile application will open onto the equipment tab.

Note: The “Equipment” tab will be empty on the first login.

The Menu Icon (1) includes “Preferences” , “Notifications and Alerts” , along with various documents covering the end-user license agreement, and privacy notice.

By tapping the Map Icon (2), the operator will be able to see the location of each vehicle on their “Equipment” tab on a map.

If a vehicle is not equipped with a telematics device, or the vehicle is a non-caterpillar machine it may be necessary to add it manually using the Add Equipment Icon (3).

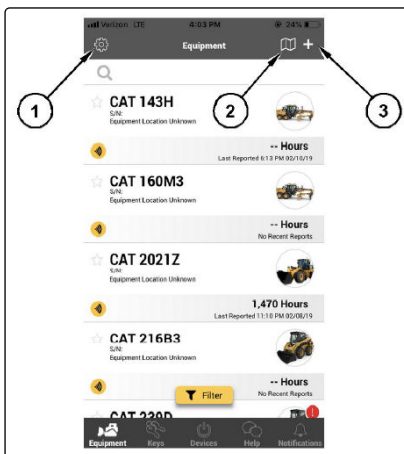

- Go to the keys tab.

Keys are necessary to connect to vehicles. If no keys are given, the screen in Illustration 434 will be displayed. The MDID is necessary to assign keys to the user account. The MDID of iOS devices is linked to the user account.

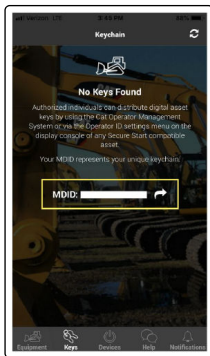

- Once the Fleet/Key configuration process has finished, tap the refresh button in the Cat App: Fleet management mobile application top right. Wait up to 30 seconds until the keys populate. If the keys do not populate, check that the MDID is correct and that the list was pushed properly in OMS.

- To connect to a machine, ensure that the machine is ON. The machine display should prompt the operator for a password. At this point on the Cat App: Fleet management mobile application go to the “Keys” tab and tap the key that matches the machine. If a vehicle is OFF, currently occupied, or too far away the key will be grayed out and say “Out of range”.

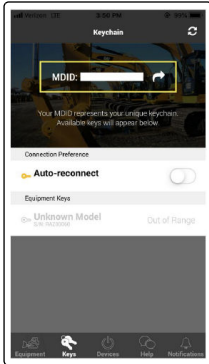

- Press the “Disconnect” button if the user wishes to disconnect. If the user wants to switch machines, tap the arrow in the upper left then tap the machine the operator wants to be switched to.

Note: Disconnect from vehicles if the user is not going to be using a vehicle again within a short time.

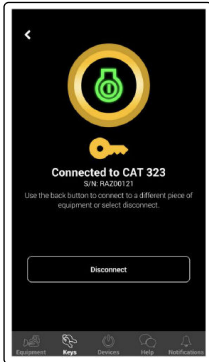

- After an operator logs in to the system successfully, an “Engine Start Allowed” message will appear across the top of the monitor. Refer to [Engine Starting*](#) (page 286) for instructions on starting the engine.

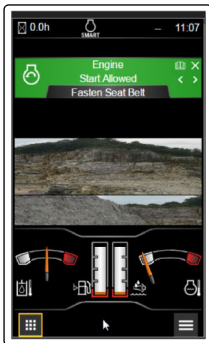

7.2.3. Engine Starting*

SMCS Code: 1000; 1090; 1456; 7000



IMPORTANT

This machine may be equipped with a Cat ® Machine Security System (MSS) and may not start under certain conditions.



IMPORTANT

The engine start switch must be in the ON position and the engine must be running in order to maintain electrical functions and hydraulic functions.

This procedure must be followed in order to prevent serious machine damage.

Note: The engine can start in areas that have temperatures as low as -18°C (0°F). For areas that are colder, a starting kit for cold weather is available.

1. Move the hydraulic lockout control to the LOCKED position.
This machine is equipped with an engine-neutral start system. The system only allows the engine to start when the lever for the hydraulic lockout control is in the LOCKED position.
2. Ensure the joysticks and travel controls are in the HOLD position.
3. The operator passcode, Bluetooth key or Cat App: Fleet management app must be authenticated before starting the engine. Once authenticated, an “Engine Start Allowed” message will appear across the top of the monitor and the start switch LED will turn green.

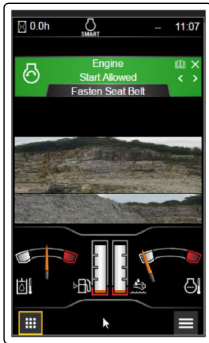

4. Bluetooth devices and passcodes can be registered using the in-cab display if the operator is logged in to the system using a master access account. Contact your Cat dealer for additional information.

Refer to *Operator Login** (page 275) for instructions.

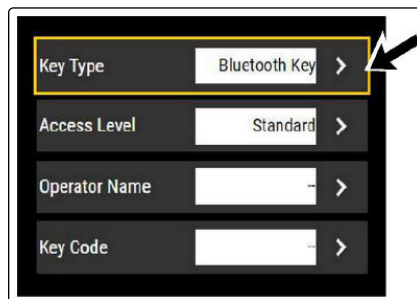
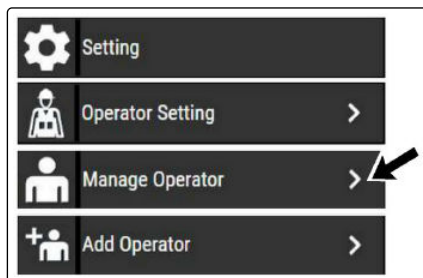

5. Before you start the engine, check for the presence of bystanders or maintenance personnel. Ensure that all personnel is clear of the machine. Briefly sound the horn before you start the engine.
6. Turn the engine start ring (1) to the ON position, then press and hold the start button (2) to start the engine. Release the button after the engine has started.

**IMPORTANT**

Do not crank the engine for more than 10 seconds. If the engine does not start, allow the starter to cool for 2 minutes before cranking again. The engine start switch must be turned to the OFF position before trying to restart.

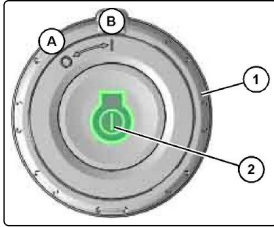

7.2.4. Engine Start Switch Troubleshooting*

Table 58.

Switch Status	Possible Cause	Resolution
Engine start switch is not illuminated	Engine start accessory power not on	Turn engine start switch ring to ON position
	Power management triggered	Cycle engine start switch ring and try to restart
Engine start switch is green	Starting component failure	Contact your Cat dealer
	Machine interlock conditions not met	Hydraulic lock in LOCKED position
Engine start switch is red	Engine shut down without cycling start switch ring	Cycle engine start switch ring and try re-start
	Operator not authenticated (Pass-code login)	Add operator to machine authorized user list
		Switch operator from guest mode using display
	Operator not authenticated (Bluetooth key)	Add operator to machine authorized user list
		Replace key fob battery
		Ensure more than 4.5 m (15 ft) from other Bluetooth equipped machine
		Alternately login with display passcode or contact local Cat dealer
	Operator not authenticated (Cat Fleet management app)	Add operator to machine authorized user list
		Ensure more than 4.5 m (15 ft) from other Bluetooth equipped machine
		Enable phone Bluetooth and connect myE-equipment app
Change Bluetooth system enable status to enabled (Cat dealer)		
Contact local Cat dealer if unable to see machine Bluetooth device		

7.2.5. Engine and Machine Warm-Up*

SMCS Code: 1000; 7000



IMPORTANT

Keep engine speed low and do not operate until the message "Warm-Up Mode Power Derate" on the monitor goes out.
If it does not go out within thirty seconds, stop the engine and investigate the cause before starting again.
Failure to do so can cause engine damage.



IMPORTANT

Always run the engine at low idle for at least ten minutes before performing any other operations in cold conditions or each time the engine oil and oil filter are changed in order to protect your engine and hydraulic components.



IMPORTANT

Depending on the ambient temperature, in order to prevent the machine operation with high speed without sufficient lubrication at the turbo bearing, the engine speed may be set to low speed and the hydraulic power minimized for a pre-determined time after the engine starts.
Refer to the turbo protection feature.

The engine may automatically change speeds when the machine is stationary and idling in cold ambient temperature for an extended time.

This is to:

- Maintain the desired coolant temperature.
- Maintain the desired operation of engine systems.

During extended idling in cold ambient conditions, engine speed may operate between 900 rpm and 1000 rpm. Operation at 1000 rpm is minimal and will only last for up to 20 minutes.

7.2.5.1. Hydraulic System Automatic Warm-Up*

This machine comes with an automatic warm-up feature that can be enabled or disabled.

If the feature is enabled, and the hydraulic oil temperature is below the threshold that has been set, a prompt will appear on the monitor after starting the machine. Follow the prompts on the monitor.

If this feature is disabled or you would like to change the temperature setting, refer to [Section: "CAT Monitoring System*" \(page 232\)](#).

Figure 196.



g06219830 Auto Warm Up-Temperature

7.2.5.2. Hydraulic System Manual Warm-Up*



WARNING

When you cycle the machine controls, the machine can move suddenly.

Contact between the machine and external objects or ground personnel can result in serious injury or death.

Before you cycle the machine controls, the machine should be located in an unobstructed, hazard-free work area that is away from external objects and ground personnel.

1. Make sure that the area is clear of personnel and equipment.

Note: The hydraulic lockout control must be in the UNLOCKED position before the hydraulic controls will function.

2. Allow the engine to warm up at low idle for at least 5 minutes. Engage the work tool controls and disengage the work tool controls. This will speed up the warm-up of the hydraulic components.

When you idle the machine for warm-up, observe the following recommendations:

- If the temperature is greater than 0°C (32°F), warm up the engine for approximately 15 minutes.
- If the temperature is less than 0°C (32°F), warm up the engine for approximately 30 minutes.
- If the temperature is less than -18°C (0°F) or if hydraulic functions are sluggish, additional time may be required.



IMPORTANT

The hydraulic oil temperature should be higher than 25° C (77° F) before performing work with the machine. Make sure that the warm-up procedure is performed.

If the hydraulic oil temperature is less than 25° C (77° F) and the machine is operated abruptly, serious damage to the hydraulic components may occur.

Note: The recommended operating temperature of the hydraulic fluid for this machine is 55 °C (131 °F).

3. To warm up the hydraulic oil, turn the engine speed dial to the medium engine speed. Run the engine for approximately 5 minutes and move the joystick intermittently from the CROWD-UP position to the HOLD position.

This allows the oil to attain relief pressure, which causes the oil to warm up more rapidly.

4. Turn the engine speed dial to the maximum engine speed and repeat Step 3.
5. Cycle all controls to circulate warm oil through all hydraulic cylinders and all hydraulic lines, and through the swing motor and travel motors.
6. Observe the gauges and the indicators frequently during the operation.



Turbo Protection Power Derate – After an engine start, the engine speed will be set to low speed and the hydraulic power limited for a time period. During this period, the monitor displays the message "Warm -Up Mode Power Derate". (Maximum is around 30 seconds). After the turbo bearing lubrication is sufficient, the engine speed goes to the setting dial speed and the monitor stops to display the message.

7.2.5.3. Improve Cold-Weather Performance*

Covers installed over the vents in the radiator compartment door will help to control overcooling in ambient temperatures below -15° C (5° F).

The materials used for the covers and the method used to install the covers are at the installer's discretion.

Install the covers if overcooling is observed while the machine is idling in ambient temperatures below -15° C (5° F).

Stop the machine, and remove the covers under the following conditions:

- The ambient temperature is above -15° C (5° F).

- The engine temperature gauge indicates overheating.
- The hydraulic oil temperature gauge indicates overheating.

7.2.5.3.1. Recommendation for Crankcase Breather Protection (Machines with C4.4 and C7.1)*

Crankcase ventilation gases contain a large quantity of water vapor.

This water vapor can freeze in cold ambient conditions and can plug or damage the crankcase ventilation system. If the engine is operated in temperatures below -25°C (-13°F), measures must be taken to prevent freezing and plugging of the breather system.

Insulated hoses and a heated canister assembly should be installed.

Consult with your CZM after-sales support for the recommended breather components for operation from -25° to -40°C (-13° to -40°F).

7.2.5.3.2. Installation*

Figure 197.

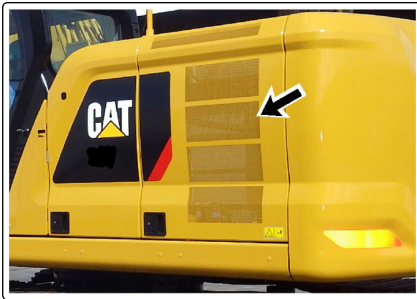

g06181368 Vent Locations on the Radiator Compartment Door

1. Clean the surface of the radiator compartment door.
2. Install the covers in the locations shown in the Illustration. The covers should fully cover the door vents.

7.2.6. Engine Starting (Alternate Methods)*

7.2.6.1. Engine Starting with Jump Start Cables (If Equipped)*

SMCS Code: 1000; 7000



WARNING

- Carefully read and understand what is written in [Section: "Batteries" \(p. 87\)](#).
- Prevent sparks near the batteries. Sparks could cause vapors to explode.
- Do not allow jumper cable ends to contact each other or the engine. Improper jumper cable connections can cause an explosion.
- Do not smoke while checking the battery electrolyte levels. Batteries give off flammable fumes which can explode.
- The liquid in a battery is an electrolyte. The electrolyte is an acid that can cause personal injury.
- Always wear eye protection when starting a machine with jump start cables.
- Improper jump-start procedures can cause an explosion resulting in personal injury or death.
- Always connect the positive of the exhausted battery (+) with the positive (+) of the new battery, and the negative (-) with the negative (-).
- Perform the bridge only with an energy source having the same voltage as the stationary machine.
- Turn off all lights and accessories on the stalled machine. Otherwise, they will operate when the energy source is connected.

Failure to follow this warning could result in death or serious injury.



IMPORTANT

To prevent damage to engine bearings and electrical circuits when you jump-start a machine, do not allow the stalled machine to touch the machine that is used as the electrical source.

Turn on (close) the battery disconnect switch before the boost connection to prevent damage to electrical components on the stalled machine.

Use only equal voltage for starting. Check the battery and starter voltage rating of your machine. Use only the same voltage for jump-starting. The use of a welder or higher voltage will damage the electrical system.

Severely discharged maintenance-free batteries do not fully recharge from the alternator after jump starting. The batteries must be charged to the proper voltage with a battery charger. Many batteries thought to be unusable are still rechargeable.

Refer to Special Instruction, SEHS7633, "Battery Test Procedure" for complete testing and charging information.

Contact CZM for more information.

When the auxiliary start receptacles are not available, use the following procedure.

1. Lower the equipment to the ground. Move all controls to the HOLD position. Move the hydraulic lockout control to the LOCKED position.
2. Turn the start switch on the stalled machine to the OFF position. Turn off all accessories.
3. Turn the battery disconnect switch on the stalled machine to the ON position.
4. Move the machine that is being used as an electrical source near the stalled machine so that the jump-start cables reach the stalled machine.

DO NOT ALLOW THE MACHINES TO CONTACT EACH OTHER.

5. Stop the engine of the machine that is being used as an electrical source. If you are using an auxiliary power source, turn off the charging system.
6. Ensure that battery caps on both machines are tight and correctly placed. Ensure that batteries in the stalled machine are not frozen. Make sure that the batteries have enough electrolyte.

Note: The positive terminal of the 24 V system of the source and the negative terminal of the 24 V system of the source must be identified correctly before the jumper cables are connected. The positive terminal of the 24 V system of the discharged battery must be identified correctly before the jumper cables are connected.

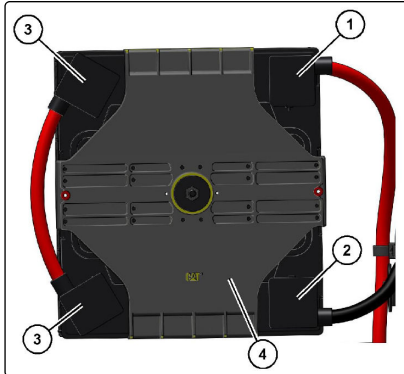

Pos.	Description
1	Red positive post to the starter
2	The black negative post connects to the battery disconnect switch.
3	Do not use these two connections for jump-starting. The red positive post is connected in series to the black negative post.
4	Cover

7. The positive ends of the jump-start cable are red. Connect one positive end of the jump-start cable to the positive cable terminal of the discharged battery. Some machines have battery sets.
Note: Batteries that are in series may be in separate compartments. Use the terminal that is connected to the starter solenoid. This battery or battery set is normally on the same side of the machine as the starter.
Do not allow the positive cable clamps to contact any metal except for the battery terminals.
8. Connect the other positive end of the jump-start cable to the positive cable terminal of the electrical source.
9. Connect one negative end of the jump-start cable to the negative cable terminal of the electrical source.
10. Finally, connect the other negative end of the jump-start cable to the frame of the stalled machine. Do not connect the jump-start cable to the battery post. Do not allow the jump-start cables to contact the battery cables, the fuel lines, the hydraulic lines, or any moving parts.
11. Start the engine of the machine that is being used as an electrical source or energize the charging system on the auxiliary power source.
12. Wait at least two minutes before you attempt to start the stalled machine. This will allow the batteries in the stalled machine to partially charge.
13. Attempt to start the stalled engine. See [Engine Starting* \(page 286\)](#) for the correct starting procedure.
14. Immediately after you start the stalled engine, disconnect the jump-start cables in reverse order.

7.2.6.2. Engine Starting with Auxiliary Start Receptacle (If Equipped)*

SMCS Code: 1000; 7000

Some products may be equipped with an auxiliary start receptacle as a standard part. If your machine is not equipped with an auxiliary start receptacle, the machine can be equipped with an auxiliary start receptacle from parts service. This will ensure that a permanent receptacle is always available to jump-start the machine.

There are two cable assemblies that can be used to jump-start the stalled machine. You can jump-start the stalled machine from another machine that is equipped with an auxiliary start receptacle or with an auxiliary power pack. CZM After-Sales Department can provide the correct cable lengths for your application.

Figure 198.

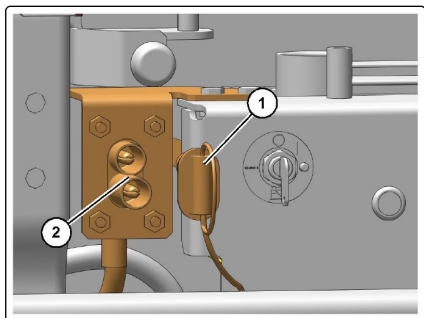

g06181572 Auxiliary Start Receptacle

Pos.	Description
1	Cover
2	Receptacle

1. Determine the reason that the engine will not start.
2. Ensure that the travel control levers on the stalled machine are in the CENTER position. Engage the hydraulic lockout control. Engage the parking brake. Lower all work tools to the ground. Move all controls to HOLD.
3. Turn the engine start switch key on the stalled machine to the OFF position. Turn off all accessories.
4. Turn the battery disconnect switch on the stalled machine to ON.
5. Move the machine that is being used as a power source close to the stalled machine. The jumpstart cables should reach the batteries on both machines.

DO NOT ALLOW THE MACHINES TO CONTACT EACH OTHER.

6. Stop the engine on the machine that is being used as a power source. If you use an auxiliary power source, turn off the charging system.
7. Connect the appropriate jump-start cable to the auxiliary start receptacle on the stalled machine.
8. Connect the other end of the jump-start cable to the auxiliary start receptacle of the machine that is being used as a power source.
9. Start the engine on the machine that is being used as a power source or energize the charging system on the auxiliary power source.
10. Wait for a minimum of 2 minutes while the batteries in the stalled machine partially charge.
11. Attempt to start the stalled engine.
12. Immediately after the stalled engine starts, disconnect the jump-start cable from the power source.
13. Disconnect the other end of the jump-start cable from the stalled machine.
14. Conclude the failure analysis on the starting charging system of the stalled machine, as required. Check the machine while the engine is running and the charging system is in operation.

7.3. MACHINE SETUP FOR DRILLING



WARNING

Any person assisting the operator in this phase must:

- Keep fingers and other body parts away from pinch points to prevent crushing injuries while operating the drilling rig.
- Never stand under or allow feet or other body parts under drilling rig components to avoid crushing hazards.
- Remain within the operator's field of vision when the machine is being moved or operated.
- Understand how to communicate with the operator using standard hand signals.

Failure to follow this warning could result in death or serious injury.

Prepare the machine for drilling after transporting it to the worksite.

Some procedures must be done with the drilling rig in motion, with the operator on board, and with help of an assistant who must perform steps directly on the machine.



WARNING

Perform these steps in the described order or you risk a tip over.

Failure to follow this warning could result in death or serious injury.

The main steps for drilling setup are:

1. Forward and Reverse Travel.
2. Turning.
3. Extending the undercarriage.
4. Positioning the mast in the work position.
5. Connecting the work tool.

7.3.1. Forward and Reverse Travel

Figure 199.

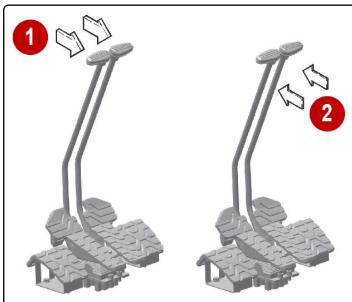

0000322 Travel-Forward and Reverse

Pos.	Description
1	Reverse Travel
2	Forward Travel

- Move both of the travel levers or travel pedals equally in the same direction to travel backward and forwards.
- Push forward on the travel control pedals or levers for forwarding travel.
- Pull back on the travel control pedals or levers for reverse travel.

- To stop, release the travel levers/pedals. The travel controls will return to a neutral position, stop the machine, and apply the travel brakes.

7.3.2. Turning

Figure 200.

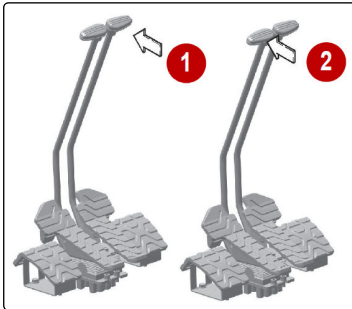

0000323 Travel-Pivot Turning

Pos.	Description
1	Pivot left turn (FORWARD)
2	Pivot right turn (FORWARD)

- Move either the left and right travel lever or pedal in a forward direction relative to the other travel lever or pedal to move the machine forward to the left or right.
- For reverse turns, move the travel lever or pedal in the reverse direction.
- Make tight radius turns by placing the travel lever on one side in a forward direction and the opposite travel lever or pedal in a reverse direction.
- When you make turns in soft material, travel in a forward direction occasionally to clear the tracks.

Figure 201.

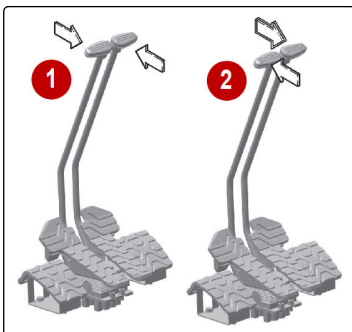

0000324 Travel-Counterrotate Turning

Pos.	Description
1	Counterrotate left turn
2	Counterrotate right turn

- Make tight radius turns by placing the travel lever on one side in a forward direction and the opposite travel lever or pedal in a reverse direction.
- When you make turns in soft material, travel in a forward direction occasionally to clear the tracks.

7.3.3. Extend the Undercarriage Tracks



WARNING

- The undercarriage must be extended or retracted when the mast is in the horizontal position.
- Do not raise the mast if the undercarriage is retracted.
- Do not swing the machine if the undercarriage is retracted.

Failure to follow this warning could result in death or serious injury. Improper use could result in a tip over.

1. On the CZM Monitor's Second Screen, press the up arrow button (1).
For more information refer to [Section: "Second Screen Settings" \(page 221\)](#).
2. Select the undercarriage option (2).

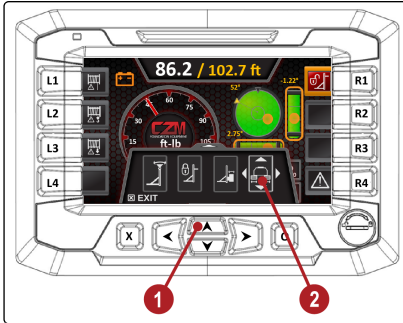

3. When selected, the undercarriage function will display four arrows. Use the up arrow button (1) or touch near the up arrow (3) on the screen to fully extend the undercarriage tracks.

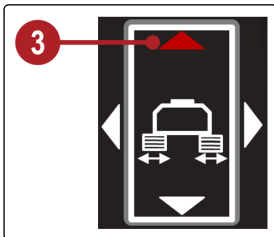

NOTICE

If the soil type hinders operations, travel the undercarriage forward and backward while trying to extend or retract the tracks.



IMPORTANT

Do not over-stress the cylinders, you risk breaking.

7.3.4. Place the Mast in the Work Position

1. Remove the lock plate (2) and transport chains (1) securing the kelly bar. Store the chains and plate.

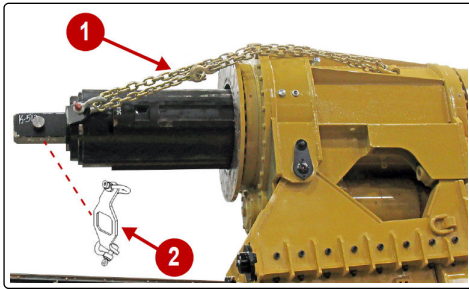

2. On the monitor, press the up arrow button (17) from the main screen to display the settings options.
3. Select the head mast fold option (18).

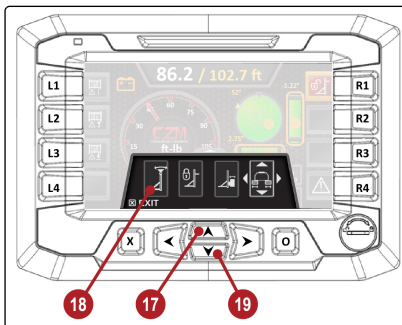

4. When selected, the head mast fold function will display four arrows.

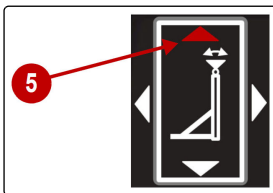

5. Use the up arrow button (3) or touch near the up arrow (5) on the display to rotate the head mast (6) into a work position.

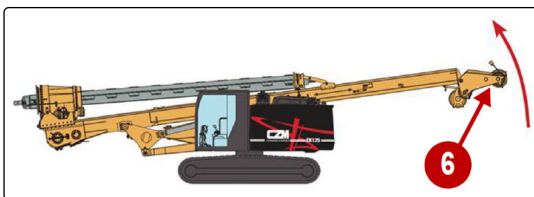

6. Raise the parallelogram until the Triangular Element is above the height of the cab.
7. Wind the main winch to apply tension to the wire rope. Do not move the kelly bar.

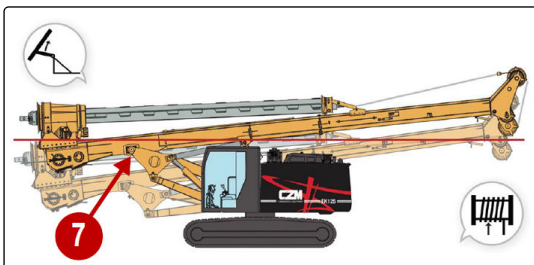

8. Tilt the mast forward. While tilting the mast:
 - Use the tilting levers to align the mast as required.

- Raise the parallelogram at the same time to maintain the balance of the drilling rig.

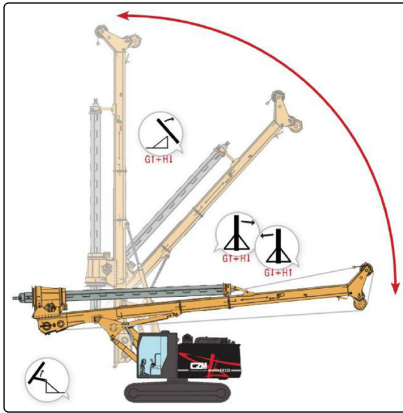

9. Make sure the A-frame (8) is below the detent (9) on the mast. Lower the rotary (10) as required.

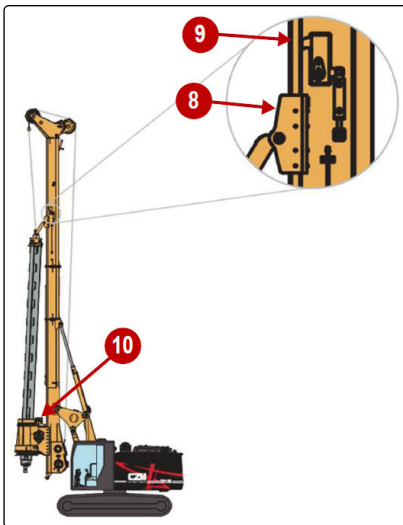

10. On the monitor, press the up arrow button (11) from the main screen to display the settings options.
11. Select the rotary tilt option (12).

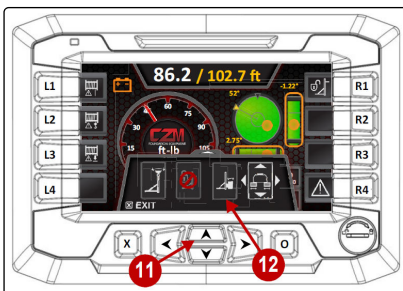

12. When selected, the rotary function will display four arrows.
13. Use the up arrow button (11) or touch near the up arrow (13) on the display to move the rotary tilt cylinders to a work position.

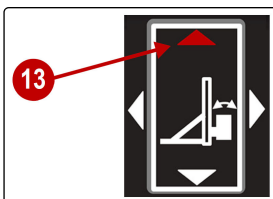

14. Select the A-frame detent arm lock option (14).

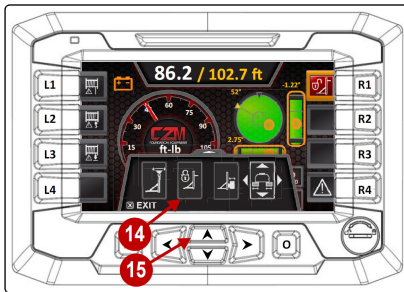

15. When selected, the detent arm lock function will display four arrows.
16. Use the up arrow button (15) or touch near the up arrow (16) on the display to place the detent arm (17) in the locked position.

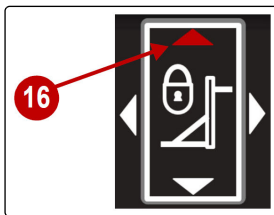

IMPORTANT

Stop immediately after the A-frame detent arm is locked and the kelly bar is aligned with the mast. Over-tensioning the main winch cable may damage the A-frame and mast detent assembly. If needed, raise the rotary to prevent the kelly bar from leaving the rotary hub.

17. Very slowly wind in the main winch to raise the kelly bar until the kelly bar is locked at its operating detent position and then immediately stop the winch.
18. Select the detent arm lock function (18).

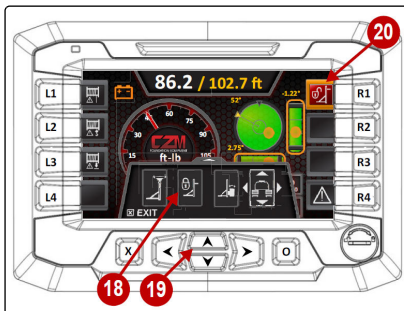

19. Use the down arrow button (19) or touch near the down arrow (21) on the display to unlock the detent arm. When unlocked, the R1 unlock icon (20) will illuminate.

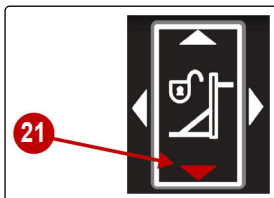

20. Lower the kelly bar slightly to allow the mast detent arm to spring back in.

7.3.5. Connect the Work Tool



WARNING

Make sure any assistant helping to connect the work tool has left the danger zone while aligning the work tool with the kelly bar.

There is a risk of the work tool falling over resulting in death or severe injury.

1. Use the auxiliary winch to secure the work tool with the square joint (toolbox) facing up.

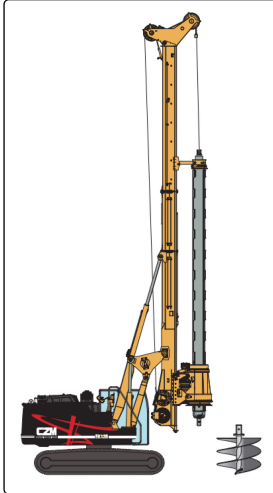

2. Move the drilling rig to align the kelly bar with the work tool.

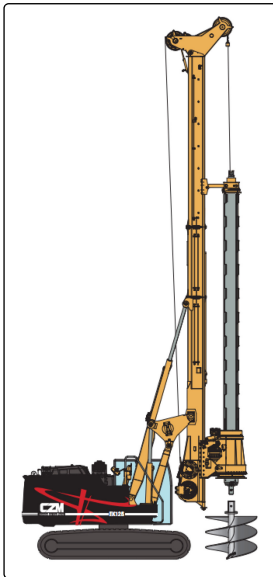

3. Lower the kelly bar and rotate the rotary as needed to align the kelly bar connector with the work tool connector.

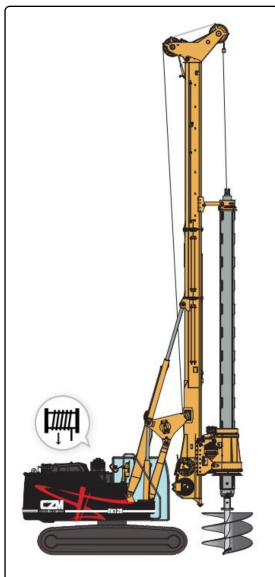

4. Install the pin (9), washer (8), and safety pin (7) to secure the work tool to the kelly bar.

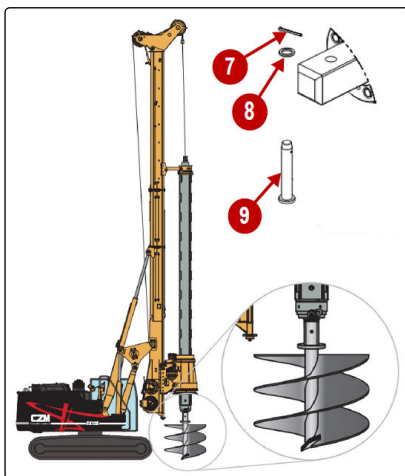

7.4. DRILLING OPERATIONS

7.4.1. Standard Drilling



IMPORTANT

Do not move the tracks or swing the mast while the kelly bar is inside the hole. The movement of the mast or machine can cause severe damage.



IMPORTANT

When raising the kelly bar, the auger may inadvertently turn clockwise and lock up the kelly bar. This often happens when the drilling auger is underwater or in collapsed soil.

If this happens, slowly turn the auger counterclockwise while raising it. If the kelly bar remains locked, lower the auger back into the hole and unlock it.

Trying to unlock the kelly bar while it is being raised could cause the locked element to fall resulting in damage to the kelly bar upper flange, breaking the main winch cable, or damaging the crowd cylinder.

1. After transporting and positioning the machine in the drilling area, setup the machine for drilling as described in the [Section: "Machine Setup for Drilling" \(page 295\)](#).
2. Position the machine so the auger is over the drilling location on stable, level ground.
3. Check the machine status:
 - The undercarriage should be facing forward, the travel motors at the rear.
 - Make sure the auger is correctly pinned to the kelly bar.
 - Make sure the safety perimeter around the machine is clear and secured.
4. Level the mast using the mast auto-level function or using the tilt cylinder controls.
5. Bring the center of the drilling tool to the center of the hole at ground level.
6. Set the drilling depth and machine swing to zero.
7. Set the engine speed to the maximum RPM for the best performance.
8. Place the rotary in the first gear.
9. To start drilling, activate the rotary clockwise rotation.
10. Simultaneously activate the crowd force.
11. Start the hole slowly, making sure the auger is kept plumb. The top part of a hole is critical in drilling a hole straight down.

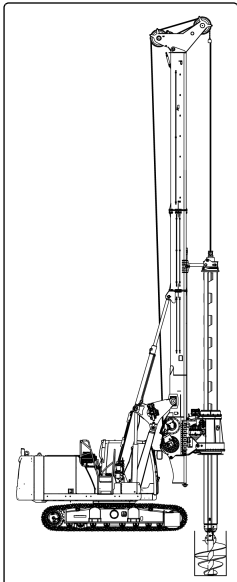

12. After drilling the length of the auger, stop drilling.

**IMPORTANT**

Do not over-drill.

Drilling beyond the top of the auger may cause the auger to become stuck in the ground, requiring the operator to back-drill.

13. Most machines have an interlocking kelly bar. To unlock the kelly bar:

**IMPORTANT**

Typically 1/2 turn per kelly bar element is required to unlock them. If you rotate the kelly bar too much, the auger will return drilling spoils back into the ground.

- a. Raise the rotary.
 - b. Activate the Pull Up to release the crowd pressure.
 - c. Slowly rotate the rotary counterclockwise. Continue until the kelly bars are unlocked. The deeper you are drilling, the more kelly bar elements are being used which will require more counter-clockwise rotation.
14. After the kelly bars are unlocked, raise the kelly bar with the main winch. Simultaneously raise the rotary.
15. You can also use the power shift to be on the high-speed spin-off. Depending on the setup, the powershift can be set to momentary, latching, or auto mode.
For more information refer to [Section: "L3–Power Shift" \(page 224\)](#).
16. After the auger is above ground level, swing the machine base to the right or left.

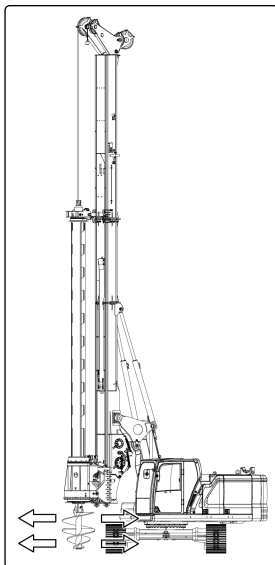

17. Spin-off the soil spoils from the auger.
18. Return the auger to the center of the hole manually or use the auto-return.
19. Lower the kelly bar inside the hole using the main winch.
20. While lowering the kelly bar, slow down before the upper flange contacts the rotary to prevent damage to the kelly bar. Also, slow down the rate of lowering when transitioning between kelly bar elements.

**NOTICE**

The machine will automatically stop the main winch when the auger reaches the bottom of the hole.
For more information refer to [Section: "Bottom Hole System" \(page 310\)](#).

21. If there is some slack in the main winch cable, raise the winch cable up slightly to put some tension on the cable before starting to drill.



IMPORTANT

Remove the slack on the cable before drilling.
Failure to do will damage the cable and could cause the tool and kelly bar to fall into the hole.

22. To lock the kelly bar, find the position of the locks and start turning the rotary clockwise and then applying crowd force.



IMPORTANT

Do not overcrowd the kelly bar.
Overcrowding is when the machine is lifted off the ground more than 2.5°. Overcrowding will cause the kelly bar to flex inside the hole and may result in it breaking from repeated fatigue stress.

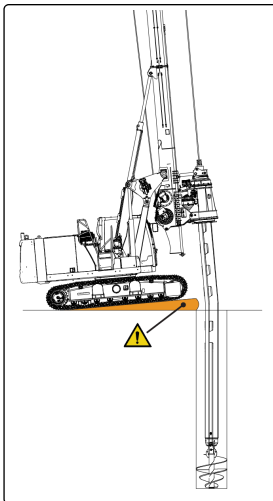

NOTICE

Some drilling rig models are equipped with an overcrowding alert or automatic protection that will alert or prevent an operator from overcrowding.

7.4.2. Automatic Drilling Functions

7.4.2.1. Auto Drill (Drill Lock)

Use the auto drill feature so that the operator does not have to hold the right joystick to the right to turn the rotary clockwise.

Figure 202.

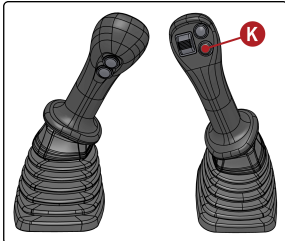

0000444 Right Joystick-K Button

To turn on the auto drill, press the auto drill push-button (K) on the right joystick.

As a safety feature, turning on the auto drill is only available if the auger is inside the hole and the machine auger is centered to the hole.

Make sure that the depth and swing angle sensor are zeroed out in this position to be able to use the auto drill function.

Any movement on the rotary joystick or pushing the auto drill push-button again deactivates the auto drill function.

The operator can still change the rotary gears, from 1 to 3 and adjust the rotary rpm without disengaging the auto drill.

7.4.2.2. Auto Crowd

The auto crowd function applies constant crowd pressure while drilling.

Figure 203.

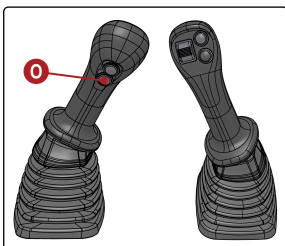

0000445 Right Joystick-O Button

The drill lock needs to be engaged before the auto crowd can be turned on.

The machine monitors the rotary torque and how much the machine is being lifted off the ground and adjusts the crowd pressure to avoid overcrowding and stalling of the rotary.

The operator can change the maximum crowd speed.

Figure 204.

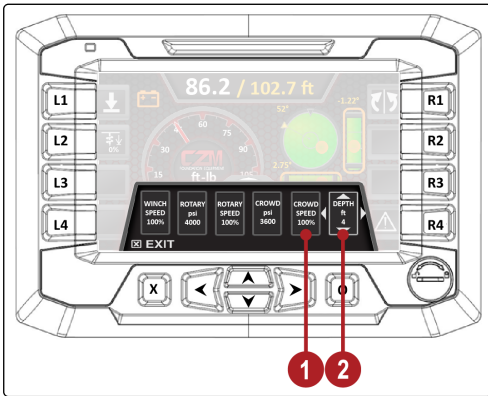

0000445 Monitor-Auto Crowd Function

Adjust the crowd speed (1) on the monitor. For more information refer to [Section: “Home Screen Settings” \(page 214\)](#).

Any movement to the crowd joystick or pressing the auto crowd push-button deactivates the auto crowd function. After the length of the auger is reached, the auto crowd function will turn off. The operator can set the auger length. Set the auger length (2) on the monitor. For more information refer to [Section: “Home Screen Settings” \(page 214\)](#).

7.4.2.3. Auto Mast Level

Figure 205.

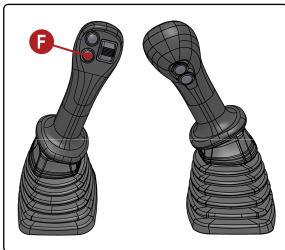

0000446 Left Joystick-F Button

The operator can auto-level the mast by holding the auto-level push button (F) on the left joystick. The mast needs to be within 10 degrees of plumb for the auto-level function to operate. Releasing the push-button stops the mast movement.

7.4.2.4. Return to Center

Figure 206.

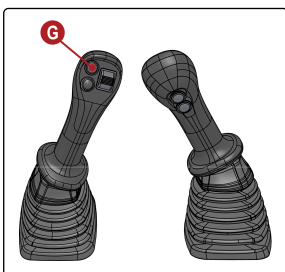

0000447 Left Joystick-G Button

Use the return to the center push-button (G) to return the center of the auger to a pre-set center of the hole.

Zero the swing position sensor at the center of the hole.

The angle at which the auger is off-center is displayed on the monitor. Releasing the push-button stops the swing movement.

Figure 207.

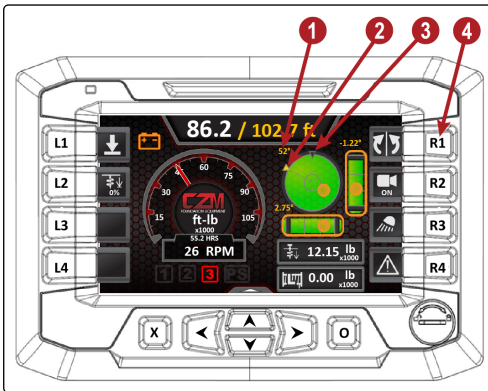

0000448 CZM Monitor-Return To Center Function

POS.	DESCRIPTION
1	Swing Angle Display
2	Swing Angle Graphic
3	Graphic Zero Point
4	Return to Center Switch

To set the current swing angle to zero, press and hold the return to center switch (4).

7.4.2.5. Rotary Auto-Shift

Figure 208.

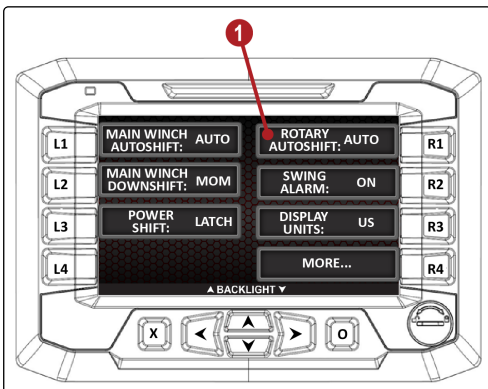

0000449 CZM Monitor-Rotary Auto-Shift Function

The operator can select to use auto gear shifting. For more information refer to [Section: “R1–Rotary Auto-Shift” \(page 224\)](#).

If Auto is selected, the machine will monitor the pressure of the rotary. If it reaches a set point, the machine will downshift the rotary gear, to avoid stalling the rotary.

If the pressure goes under another set point, the machine will up-shift the rotary gear to increase the drilling speed. The machine will only up-shift the gear back to the selected gear by the operator.

7.4.2.6. Main Winch Auto-Shift

Figure 209.

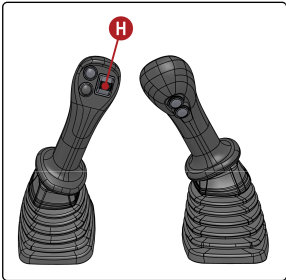

0000450 Left Joystick-H Button

The operator can select to use automatic gear shifting on the main winch.

Figure 210.

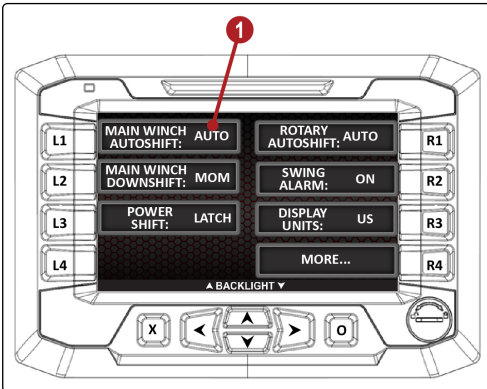

0000451 Monitor-Main Winch Auto-Shift Function

Set the main winch auto-shift (1) on the monitor. For more information refer to [Section: “L1–Main Winch Auto-Shift” \(page 224\)](#).

When auto-shift is enabled for the main winch, the machine monitors the pressure of the main winch.

When the pressure exceeds the high set point, the machine downshifts the main winch gear to provide more torque.

If the pressure goes under the low set point, the machine up-shifts the main winch gear to increase the line speed.

7.4.2.7. Auto Power Shift (Spin-Off)

Figure 211.

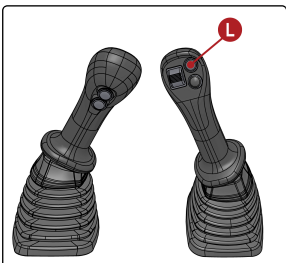

0000452 Right Joystick-L Button

The power shift (spin-off) button can be set to operate as:

- Momentary
- Latching
- Automatic

Figure 212.

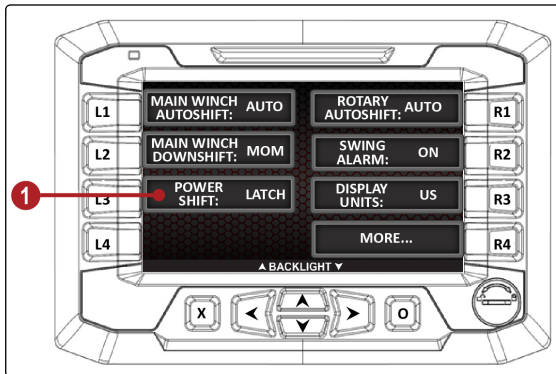

0000453 Monitor-Power Shift Function

Set the power shift (1) on the monitor. For more information refer to [Section: “L3–Power Shift” \(page 224\)](#).

- If the Momentary operation is selected, hold the push button to keep the spin-off on.
- If the Latching operation is selected, press the push button to turn the spin-off on and push it again to turn off the spin-off.

When auto spin-off is on, make sure to zero the depth and the swing angle sensors when the auger is positioned at the top of the hole.

The machine automatically turns on the spin-off, after the auger is above ground level and the base machine swings past a set angle.

Spin-off turns off automatically after the auger returns to the center of the hole and the auger is placed inside the hole.

Spin-off can be manually turned on and off by pressing the push button.

7.4.2.8. Overcrowd Protection System

The machine is equipped with an Overcrowd Protection System.

This feature prevents the operator from lifting the machine off the ground beyond a set angle by slowing down the crowd speed according to a pre-set rotary torque.

Adjust the pre-set rotary torque on the monitor.

7.4.2.9. Bottom Hole System

The Bottom Hole System automatically stops the lowering of the kelly bar to prevent the main winch from unwinding too much the wire rope from its drum.



IMPORTANT

For some maintenance and machine setup, you will need to disable the bottom hole system. This allows the operation of the main winch when there is no tension on the wire rope.

7.4.3. Drilling On Rock (Boulders)

Figure 213.

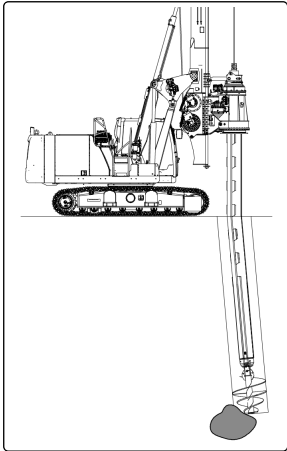

0000315 Drilling On Rock-Boulders

When drilling on boulders or solid rock, an auger can start to push to the side, going off-center. This may flex the kelly bar and cause it to break with repeated fatigue stress.

In some situations, the machine operator should change the drilling tool to a core barrel tool to keep the hole plumb and avoid failure of the kelly bar.

Drilling on rock can take time and cause a lot of wear to the machine. Make sure you have the correct tool, either a rock auger or a core barrel with the correct teeth.

Change the teeth before they wear out or if they break, inspecting them constantly. Run the machine at very low rpm, to avoid wearing down the auger teeth too quickly.

The machines are equipped with a rock drill mode, which can be changed on the base machine monitor.

Rock drill mode supplies the rotary with hydraulic fluid from just one main pump, this reduces the speed of the rotary by 50%, without affecting the torque.

The operator may decide to reduce the speed even further, to as low as 3-4 rpm. They can do that by adjusting the rotary speed at the CZM monitor.

Figure 214.

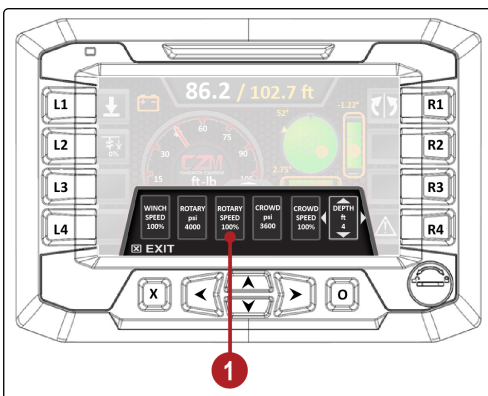

0000442 Monitor-Rotary Speed Function

i NOTICE
 Adjust this function on the CZM Monitor.
 For more information refer to *Section: "Home Screen Settings" (page 214)*.

For smoother drilling operation, the operator can use the rotary drill lock and the auto crowd when drilling on rock.

7.4.4. Drilling on Slurry/Polymer or Bentonite

While drilling with a slurry, polymer, or bentonite, it may be beneficial to reduce the main winch speed, so that the slurry does not get too agitated.

A slower winch speed will also reduce the washing of the auger while it is going up, removing all the drilled soil spoils.

Figure 215.

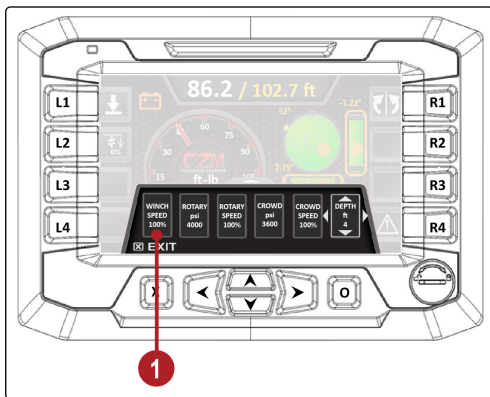

0000443 Monitor-Winch Speed Function

7.4.5. Installing a Casing



WARNING

Handling casing with a drilling rig is a dangerous operation with many hazards:

- Make sure that the casing does not exceed the stability parameters of the drilling rig.
- Make sure the casing is well secured to the rotary, kelly bar, or auxiliary winch while lifting it off the ground.
- Do not leave segments of casing standing up on the job site. Casing segments on the ground must be secured to prevent rolling.

Failure to follow this warning could result in death or serious injury.

When drilling under the water table or on unstable soil, a method of stabilizing the ground conditions might be required. Some methods to stabilize the ground conditions for drilling include:

- Using a stabilizing fluid such as polymer or bentonite.
- Using a casing.

There are two types of casings:

- J-lock. See [“J-Lock Casing” \(page 313\)](#).
- Segmented. See [“Segmented Casing” \(page 314\)](#).

7.4.5.1. J-Lock Casing



WARNING

Before using the service winch to lift the casing, make sure the operation is within the safety limits of the machine.

For more information refer to:

- Section: 'Auxiliary Winch ' (page 174).
- Section: 'Auxiliary Winch - Forward Facing Tilted ' (page 146).
- Section: 'Auxiliary Winch - Forward Facing Tilted ' (page 160).

1. Drill with an auger slightly larger in diameter than the casing down to the depth where the soil starts to become unstable.
2. Install the casing inside the open hole using a crane or the auxiliary winch.
3. Remove the auger and install a crossbar at the bottom of the kelly bar.

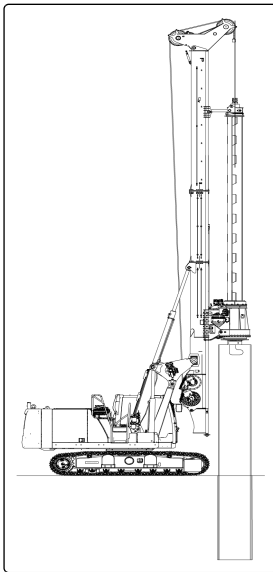

4. Hook the bar to the casing and drive the casing down into the ground until the top is flush with the ground level.
5. It may be necessary to change back to an auger, drill further inside the casing, and then change back to the crossbar.



IMPORTANT

Depending on the diameter of the casing, it might be possible to add a crossbar to the bottom of the rotary, avoiding having to remove the auger for driving the casing.

The casing only secures the top part of the hole. A polymer or bentonite additive may be necessary to stabilize the bottom section of the hole.

7.4.5.2. Segmented Casing

1. To use segmented casing, the machine requires:
 - Universal joint attached to the bottom of the rotary.
 - Casing driver attached to the rotary.

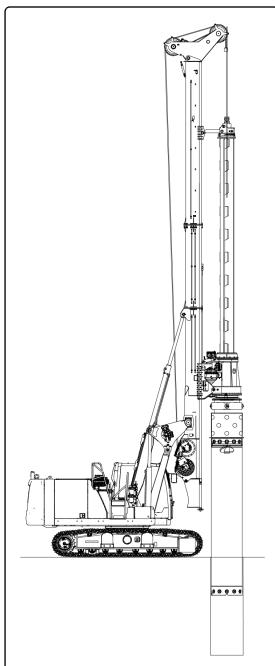

2. Each segment of the casing is pinned to the casing driver and it can then be driven into the ground.
 - a. Driving the casing is done with the operator turning the casing clockwise and applying crowd force. he may also decide to oscillate the casing backward and forward.
 - b. The auger stays connected to the kelly bar stub.
 - c. Advance the casing as far as possible, disconnect it from the rotary and then drill inside the casing, making sure the auger doesn't go past the casing length inside the ground. If the auger drills below the casing, the auger may become stuck on the outside of the casing.
 - d. Add additional segments of the casing, bolting them together until the final depth is reached.
3. After the final depth is reached, the grouting phase can start.
4. Usually, after some grout is added from the bottom up, the operator will start removing segments of the casing, making sure he does not remove more segments than the current length of grout, exposing soil. this could contaminate the grout in the pile with soil.
5. To remove the casing, turn the casing clockwise and pull up the rotary with the crowd cylinder. Or you can oscillate the rotary back and forward while pulling it up. You may need to position the mast foot down to the ground.
6. To disconnect each segment of the casing, first secure the bottom segments of the casing that are still in the hole so that they don't fall back down into the hole.
7. Unbolt the segment and remove it from the hole to the side and then unpin it from the rotary.

7.5. STOPPING THE MACHINE

SMCS Code: 7000

7.5.1. Parking*



WARNING

Leaving the machine unattended when the engine is running may result in personal injury or death. Before leaving the machine operator station:

1. Neutralize the controls.
2. Lower the work tool to the ground. Apply a slight downward pressure.
3. Deactivate all work tools.
4. Place the lever for the hydraulic lockout control in the LOCKED position.



NOTICE

There may be regulations that define the requirements for the operator and/or support personnel to be present when the engine is running.

Park on a level surface. If the machine must be parked on a grade, chock the tracks securely.



NOTICE

- The swing parking brake is automatically applied when the machine is stopped.
- The swing parking brake is released when the engine is running and the joystick is activated.

1. Turn the engine speed dial counterclockwise to reduce engine speed.
2. Release the travel controls to stop the machine.
3. Lower the work tool to the ground. Apply a slight downward pressure.
4. Move the hydraulic lockout control to the LOCKED position.

7.5.2. Stopping the Engine*

SMCS Code: 1000; 7000



IMPORTANT

Stopping the engine immediately after it has been working under load can result in overheating and accelerated wear of engine components.

Refer to the following procedure to allow the engine to cool and prevent excessive temperatures in the turbocharger housing, which could cause oil coking problems.



IMPORTANT

Never turn the battery disconnect switch to the OFF position while the engine is running. Serious damage to the electrical system may result.

1. Park the machine on level ground. Refer to [Stopping the Machine \(page 315\)](#) for the recommended procedure.
2. While the machine is stopped, run the engine for 5 minutes at low idle. Idling the engine allows hot areas of the engine to cool gradually.
3. Turn the engine's start switch to the OFF position.



IMPORTANT

If the "Regen Active" indicator is illuminated, do not shut off the engine.

Refer to [Section: "CAT Monitoring System*" \(page 232\)](#) for more information on indicators.

7.5.3. Engine Shutdown Switch*



IMPORTANT

- Perform a walk-around inspection after the actuation of a shutdown device.
- Take necessary corrective action to resolve the cause of the shutdown.
- Ensure that no additional damage has been done or could occur before returning to operation.

Turn the engine start switch to the OFF position. If the engine does not stop, perform the following procedure.



NOTICE

Always use the engine start switch to stop the engine.
Use the engine stop control as an alternate method to stop the engine if the start switch fails.

Figure 216.

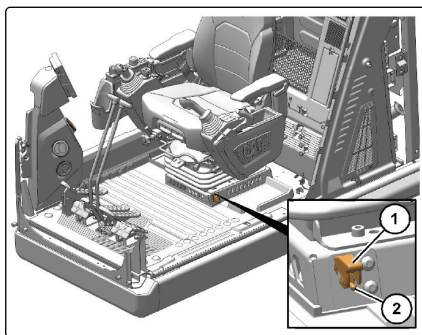

g06181487 Engine Shutdown Switch

1. The engine shutdown switch is located below the left side of the operator seat.
2. Lift cover (1).
3. Push switch (2) upward. Pushing the switch upward should stop the engine and prevent the engine from being started again.
4. Return the switch to the original position. The engine will be enabled to start.



IMPORTANT

Do not operate the machine again until the malfunction has been corrected.

5. Use the method that follows if the previous steps do not stop the engine.

7.5.4. Stop the Engine if an Electrical Malfunction Occurs*

Turn the engine start switch to the OFF position. If the engine does not stop, perform the following procedure.

Figure 217.

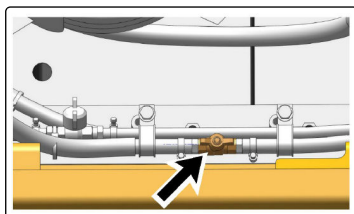

g06214480 Fuel Shutoff Valve

The fuel shutoff valve is located behind right side access door.

Shut off the fuel supply by turning the fuel shutoff valve clockwise. The engine will stop after consuming the fuel in the fuel line. The engine may continue to run for a few minutes.

Repair the engine before you restart the engine. The fuel system may need to be primed. See [Section: "Priming the Fuel System*" \(page 434\)](#) for instructions.

7.5.5. Leaving the Machine*

SMCS Code: 7000

Figure 218.

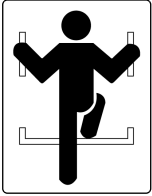

0000105 Mount and Dismount

1. Use the steps and the hand holds when you dismount. When you dismount, face the machine and use both hands.
2. Inspect the engine compartment for debris. Clean out any debris to avoid a fire hazard.
3. Remove all flammable debris from the front bottom guard through the access doors to reduce a fire hazard. Discard the debris properly.
4. Always turn the battery disconnect switch to the OFF position before leaving the machine.
5. If the machine will not be operated for a month or more, remove the battery disconnect switch key.
6. Lock all compartments and all vandalism covers (if equipped).

7.6. MACHINE STORAGE

The specified storage period of this machine is 1 year.

After the specified storage period has expired, contact CZM to inspect, repair, rebuild, install remanufactured, or install new components, and disposal options, and to establish a new specified storage period.

If a decision is made to remove the machine from service, refer to *Decommissioning and Disposal** (page 319) for further information.

7.6.1. For a Short Period of Time

If the machine must be stored for a short period of time (a few days), the operator must:

1. Place the machine in the transport position. Refer to *Machine Setup For Transportation* (page 360).
2. Park the machine on a dry, level, solid surface that is free of any debris.
3. Remove the engine's starting key and hand it over to the person in charge.
4. If present, remove all the remote controls and the remote controls cables.
5. Turn the battery disconnect switch in the OFF position. Refer to *Battery Disconnect Switch** (page 186).
6. Before starting the machine again, perform general maintenance.

7.6.2. For a Long Period of Time

If the machine must be stored for a long period of time (from a week to 1 year), the operator must:

1. Place the machine in the transport position. Refer to *Machine Setup For Transportation* (page 360).
2. Park the machine on a dry, level, solid surface that is free of any debris.
It is recommended to park the machine indoors and cover it.
3. Remove the engine's starting key and hand it over to the person in charge.
4. If present, remove all the remote controls and the remote controls cables.
5. Turn the battery disconnect switch in the OFF position. Refer to *Battery Disconnect Switch** (page 186).
6. Completely clean the machine, its accessories, and tools.
7. Lubricate all the machine components. Refer to *Lubricating The Machine* (page 406).
8. Before starting the machine again, perform thorough maintenance.

7.7. DECOMMISSIONING AND DISPOSAL*

When the product is removed from service, local regulations for product decommissioning will vary. Disposal of the product will vary with local regulations.

Rely on specialized companies able to carry out this operation in compliance with current regulations.

Utilize appropriate personal protective equipment when decommissioning and disposing of the product.

Consult CZM for additional information. Including information for component remanufacturing and recycling options.



ENVIRONMENTAL NOTICE

Improper waste disposal can harm the environment.

Obey all local regulations for the decommissioning and disposal of materials.

8. ASSEMBLY

8.1. ASSEMBLING THE MACHINE'S COMPONENTS



WARNING

Any person assisting the operator in this phase must:

- Keep fingers and other body parts away from pinch points to prevent crushing injuries while operating the drilling rig.
- Never stand under or allow feet or other body parts under drilling rig components to avoid crushing hazards.
- Remain within the operator's field of vision when the machine is being moved or operated.
- Understand how to communicate with the operator using standard hand signals.

Failure to follow this warning could result in death or serious injury.

Some procedures must be done with the drilling rig in motion, with the operator on board, and with help of an assistant who must perform steps directly on the machine.

If some components were disassembled, follow these steps to mount them again.



WARNING

Perform these steps in the described order or you risk a tip over.

Failure to follow this warning could result in death or serious injury.

1. [CZM Counterweight \(Additional\) \(page 321\)](#)
2. [CAT Counterweight \(Main\) \(page 322\)](#)
3. [Rotary \(page 324\)](#)
4. [Swivel \(page 326\)](#)
5. [A-Frame \(page 327\)](#)
6. [Kelly Bar \(page 328\)](#)

8.1.1. CZM Counterweight (Additional)



WARNING

- When the counterweight is removed, the stability of the machine is decreased.
- The mast must be facing forward, to the front of the machine.
- The tracks must be extended when removing and installing the counterweight.

Avoid any sudden movements or actions that may cause the machine to tip over.

Failure to follow this warning could result in death or serious injury.

1. Prepare the machine for service. For more information refer to [Prepare the Machine for Maintenance* \(page 384\)](#).
2. Extend the tracks. See [Extend the Undercarriage Tracks \(page 297\)](#) for more information.
3. Attach an appropriate lifting device to the 2 lifting lugs (2) on the CZM counterweight. The CZM counterweight weighs 1,300 lbs (600 kg).

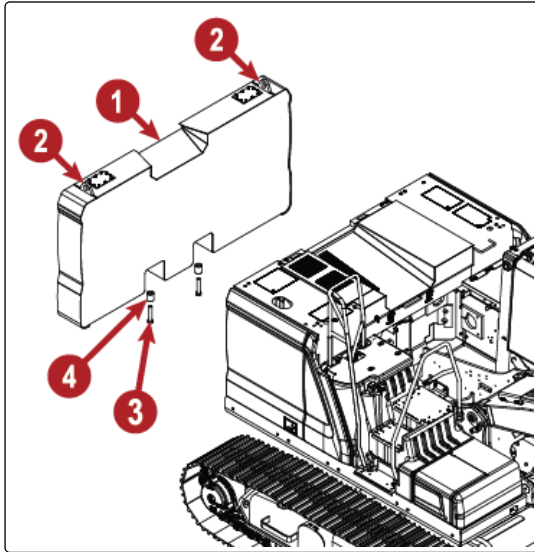

4. Lift the CZM counterweight into position on the machine.
5. Secure the CZM counterweight with 2 spacers (4) and 2 bolts (3).
6. If required, install two lifting eye bolts (M42 x 4.5) to the CAT counterweight.

8.1.2. CAT Counterweight (Main)



WARNING

- When the counterweight is removed, the stability of the machine is decreased.
- The mast must be facing forward, to the front of the machine.
- The tracks must be extended when removing and installing the counterweight.

Avoid any sudden movements or actions that may cause the machine to tip over. Failure to follow this warning could result in death or serious injury.

1. Prepare the machine for service. For more information refer to *Prepare the Machine for Maintenance** (page 384).
2. Extend the tracks. See *Extend the Undercarriage Tracks* (page 297) for more information.
3. Make sure the CZM counterweight is mounted. If not, follow the procedure *CZM Counterweight (Additional)* (page 321).
4. Use an appropriate lifting device to position the CAT counterweight (7) on the machine. The CAT counterweight weighs 11,880 lbs (5.400 kg).



DANGER

During this operation, the Technician must get under the counterweight to install/remove the connecting bolts, while the counterweight will remain hanged to the lifting device above him.

It is extremely important to verify that the lifting device and its straps/chains are rated for the weight to be lifted and that they are not damaged.

Failure to follow this warning will cause serious injury or death.



DANGER

Do not swing or travel the machine without the counterweight bolts installed.

Failure to follow this warning will cause serious injury or death.

Secure the CAT counterweight with four bolts and spacers (8).



DANGER

Bolts must be tightened at the correct torque. See *Section: "Torque Specifications "* (page 525) for more information.

Failure to do so could result in the counterweight falling over during the operation.

Failure to follow this warning will cause serious injury or death.

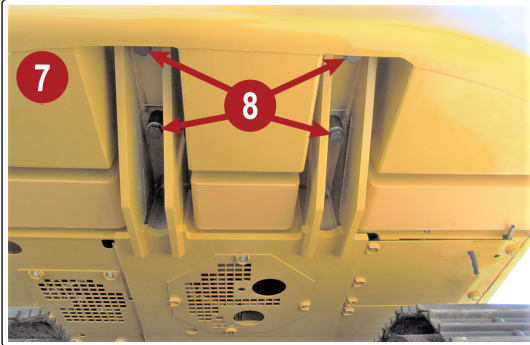

6. Connect the camera connector (10) from the left side compartment near the radiator and condenser (9).

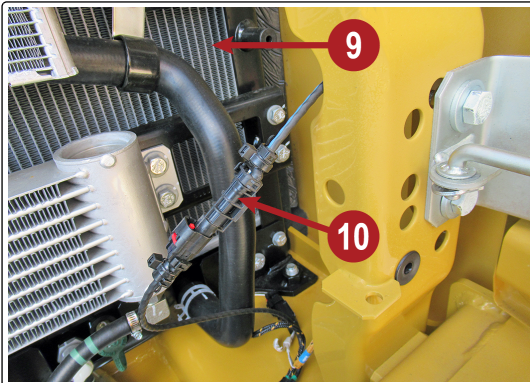

8.1.3. Rotary

1. Place the mast in the vertical operating position (leveled).
2. Position the machine so that:
 - The bottom mast is extended and touching the ground.
 - The foot mast rails are above and aligned between the wear pads on the rotary head sled.
 Use wood blocking to support the rotary head off the ground.

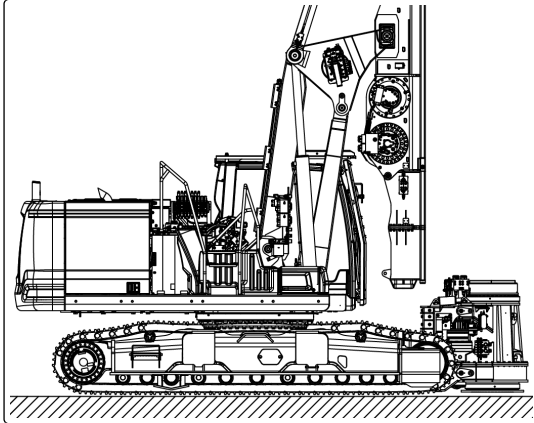

3. Remove the mast lock assemblies from both sides of the foot mast.

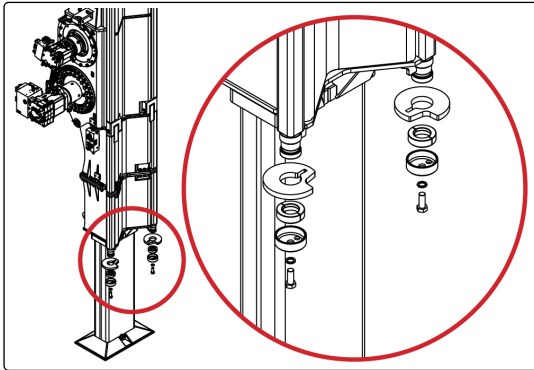

4. Slide the rotary into the mast rails by following one of the procedures below:

With the use of a forklift:

 - a. Use a forklift to raise the rotary and slide it up the rails of the mast.
 - b. Stop once the bottom of the foot mast rail is below the rotary sled.
 - c. The forklift must support the rotary until it is properly secured on the crowd cylinder, and mast locks are installed (until step 5).

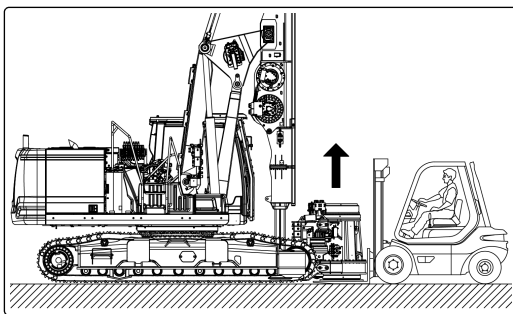

If a forklift is not available:

- a. Slowly lower the mast while moving the machine backward. The “auto-tilt” function must remain activated to ensure the mast is vertical throughout the procedure.

- b. Retract the bottom mast as required.
- c. Stop lowering the mast when the bottom of the foot mast rail is below the rotary sled.

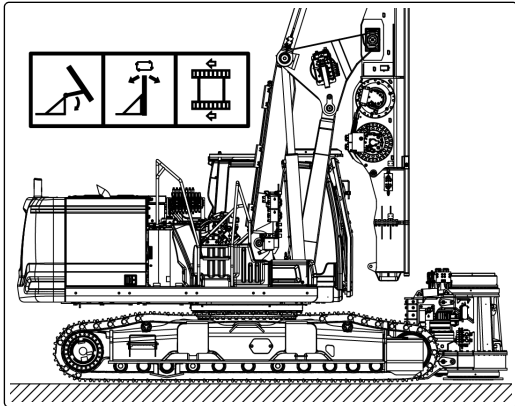

5. Align the crowd cylinder rod end with the rotary head. Install the rod pin and fasten the lock bolt to secure the crowd cylinder to the rotary sled. If necessary, slightly move the crowd cylinder to facilitate the installation of the pin.

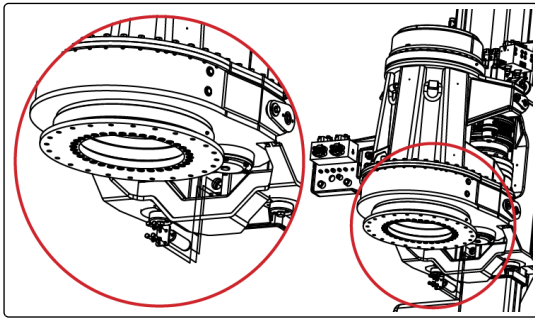

6. Install the mast lock assemblies on both sides of the foot mast.

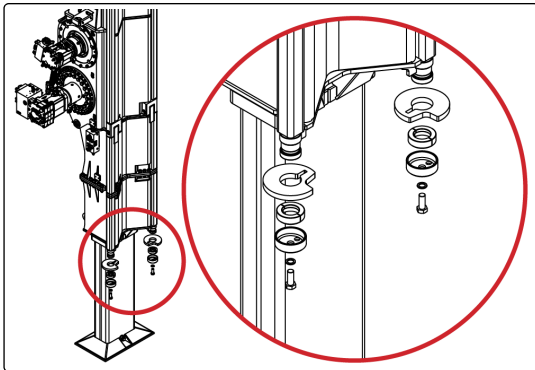

7. Connect the hydraulic lines to the rotary sled manifold. Use tags made during disassembly for identification of connections.

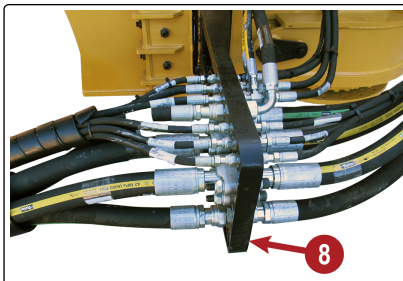

8. Connect electrical connectors.

8.1.4. Swivel

1. Position the swivel (1) in the kelly bar (4) and align the swivel pin hole with the access hole in the kelly bar.
2. Attach one snap ring (3) to the swivel pin (2) and install the pin into the kelly bar.
3. Install the other snap ring.
4. Install the kelly bar.

See [Section: "Kelly Bar" \(page 328\)](#) for more information.

Figure 219.

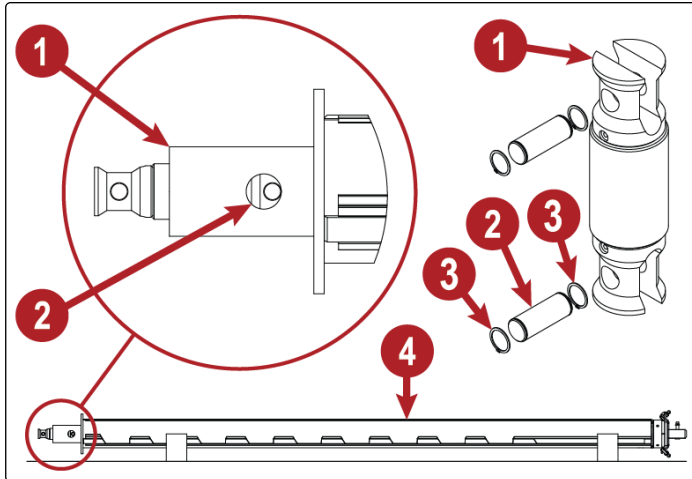

0000365 Assembly-Swivel

Pos.	Description	Qty
1	Swivel	1
2	Swivel Pin	2
3	Snap Ring	4
4	Kelly Bar	1

8.1.5. A-Frame

WARNING
 The A-frame maintenance must be performed with the A-frame at ground level. Failure to follow this warning could result in death or serious injury.

IMPORTANT
 Use two wood blocks with a half-round cut in the center to cradle the kelly bar for support. Make sure the kelly bar does not move during this procedure.

1. With the assistance of an auxiliary hoist that supports the load of the kelly bar, lay the kelly bar on the wood support blocks (3).
2. Position the A-frame (2) next to the kelly bar so that both are concentric ensuring the A-frame is sideways and properly resting on the ground.
3. Support the A-frame with the auxiliary winch.
4. Carefully slide the A-frame in until the bearing and kelly bar are in contact and the bolt holes align.
5. Place all the bolts with washers and nuts and hand tighten them.
6. Tighten the bolts (4) in the sequence shown above. Tighten bolts to specifications. See [Section: "Torque Specifications" \(page 525\)](#) for more information.
7. Attach the main winch cable to the swivel.
8. Install the kelly bar. See [Section: "Kelly Bar" \(page 328\)](#) for more information.

Figure 220.

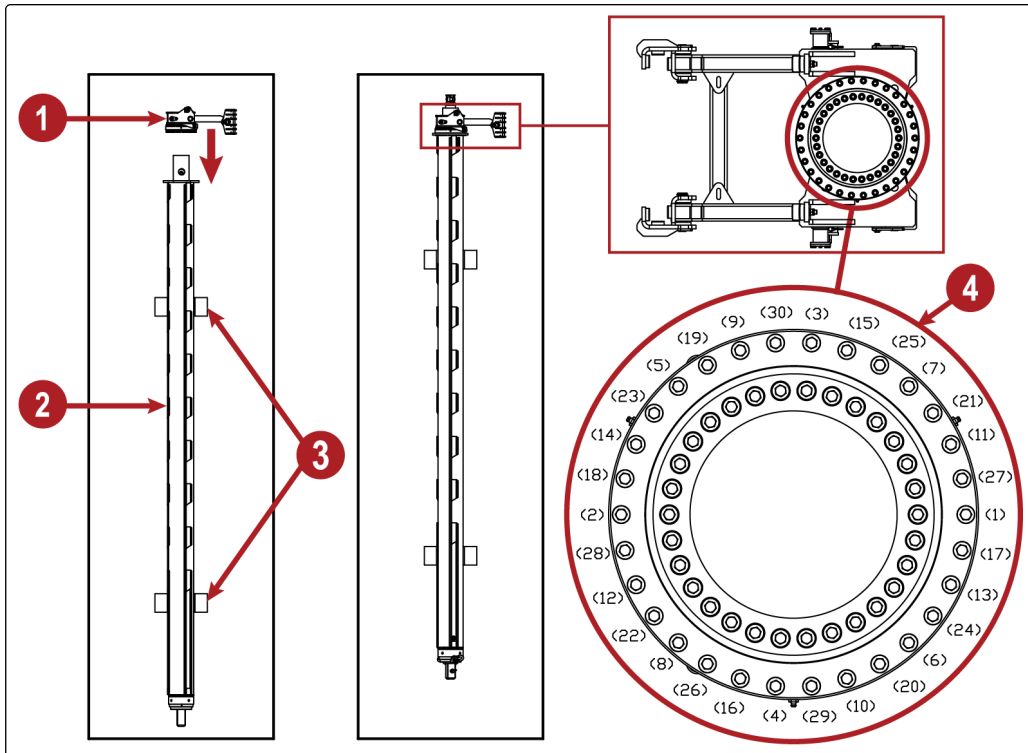

0000271 Assembly-A-Frame

8.1.6. Kelly Bar

8.1.6.1. Standard Mast Version

1. Start with the kelly bar laying down horizontally on wood support blocks.



IMPORTANT

Use two wood blocks with a half-round cut in the center to cradle the kelly bar for support. Make sure the kelly bar does not move during this procedure.

2. Position the drilling rig in front of the top of the kelly bar.
3. Lower the rotary to its lowest position on the mast.
4. Turn off the bottom-hole system to allow the main winch cable to be unwound without any tension on the cable.

See [Section: "L3–Main Winch Bottom Hole Exclusion Switch" \(page 219\)](#) for more information.

5. Unwind the main winch cable as needed to connect to the kelly bar.
6. Attach the swivel to the kelly bar.
See [Swivel \(page 326\)](#) for more information.
7. Attach the A-frame to the kelly bar.
See [A-Frame \(page 327\)](#) for more information.
8. Attach the main winch to the swivel on top of the kelly bar.



IMPORTANT

Be sure that the swivel is facing up when attaching it to the main winch. This position allows the main winch cable to freely turn up/down. If it is not, the swivel will be damaged, and/or the kelly bar eye will bend, causing serious problems to the machine.

9. Attach the auxiliary hoist to the A-frame to support the A-frame.
10. Lift the kelly bar/A-frame assembly off of the ground with the main winch.
11. Remove two square lynch pins (2) from the lock pins (1) for the A-frame assembly.

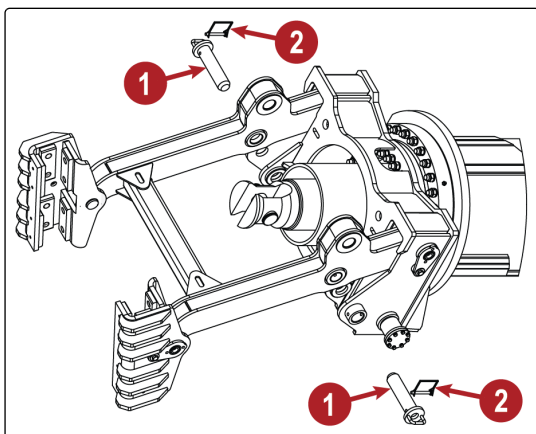

12. Using a rubber mallet, strike the two lock pins on the A-frame to remove them from the A-frame assembly.

13. Remove one snap ring (6) and bolt/washer (5) from the A-frame foot pivot pin.

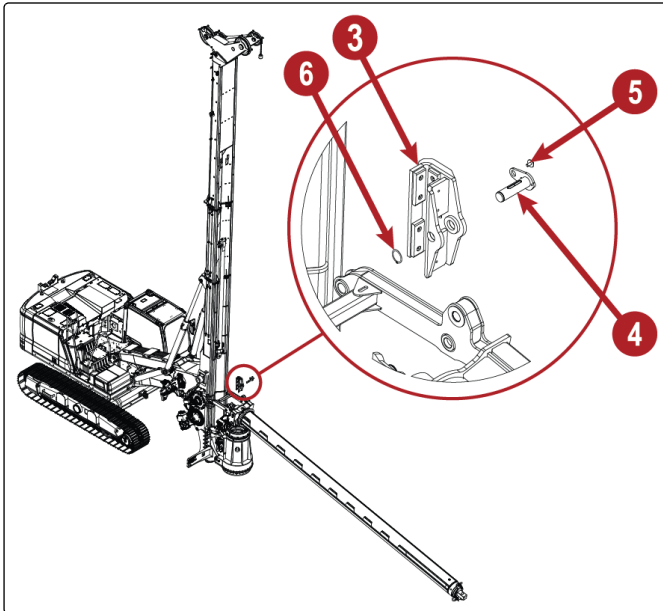

14. Remove the A-frame foot pivot pin (4) and remove the A-frame foot (3) from the A-frame. Leave the other A-frame foot attached to the A-frame.
15. Lift the Kelly bar assembly only enough to get the A-frame assembly onto the mast. Move the machine forward as the Kelly bar is raised, don't drag the Kelly bar on the ground to the machine.
16. Use the auxiliary hoist to position the A-frame perpendicular to the mast.
17. Position the A-frame and the one-installed wear plate on the mast.
18. Position the other A-frame foot on the mast and align the mounting hole on the A-frame with the mounting hole on the A-frame foot.
19. Install the A-frame foot pivot pin to secure the A-frame foot to the A-frame assembly. Secure the pivot pin with a snap ring (6) and bolt/washer (5).
20. Attach a guide rope to the Kelly bar and have an assistant guide the Kelly bar into the rotary.

WARNING

Any person assisting the operator in this phase must:

- Keep fingers and other body parts away from pinch points to prevent crushing injuries while operating the drilling rig.
- Never stand under or allow feet or other body parts under drilling rig components to avoid crushing hazards.
- Remain within the operator's field of vision when the machine is being moved or operated.
- Understand how to communicate with the operator using standard hand signals.

Failure to follow this warning could result in death or serious injury.

CAUTION

Have an assistant with a rope attached to the Kelly bar guide the Kelly bar as the rotary is raised. Improper alignment/contact of the Kelly bar and rotary can result in machine damage.

21. Lift the Kelly bar slowly above the rotary head, the A-frame will slide up the mast. Tilt the mast forward as needed to keep the Kelly bar from hitting the rotary head.

22. After the bottom of the kelly bar (7) is above the rotary head (8), tilt the mast back to align the kelly bar with the center of the rotary head.

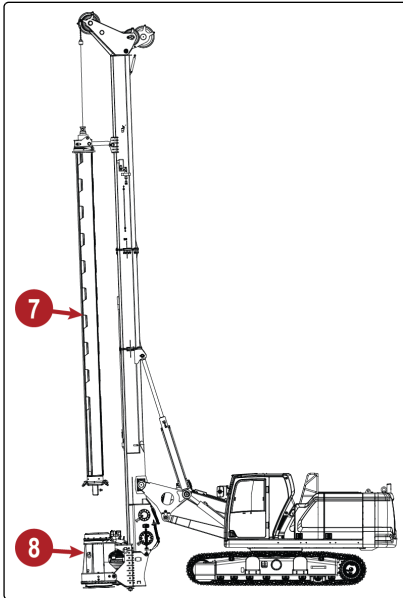

23. Slowly lower the kelly bar (7) into the rotary head (8). Rotate the rotary as needed to align with the kelly bar.
24. Once the kelly bar is inserted into the rotating head lift the rotary head up the mast to the desired position.
25. Place the mast in the transport position.
26. Insert the two lock pins (9) into the A-frame assembly.

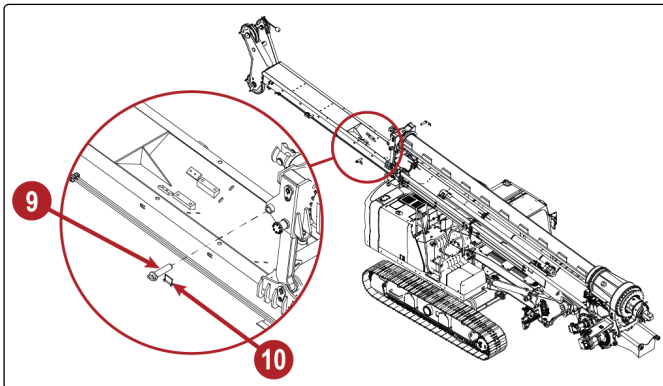

27. Insert the two square lynch pins (10) to secure the lock pins for the A-frame assembly.
28. Return the mast to the vertical working position.

8.1.6.2. Short Mast Version

1. Position the drilling rig in front of the top of the kelly bar (1) at a maximum distance of 3m (10ft).

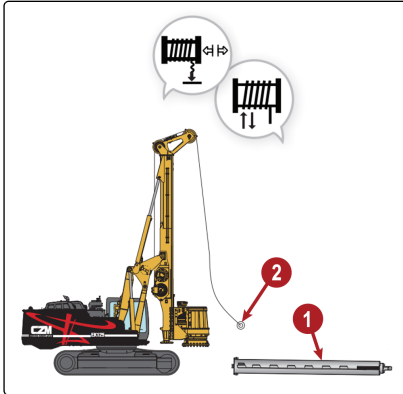

2. Lower the rotary to its lowest position on the mast.
3. Turn off the bottom-hole system to allow the main winch cable to be unwound without any tension on the cable.

See [Section: "L3–Main Winch Bottom Hole Exclusion Switch" \(page 219\)](#) for more information.

4. Unwind the main winch cable as needed to connect to the kelly bar.
5. Attach the main winch cable in the cable swivel (3) and install the pin (4) that locks the thimble. Install the retaining rings (5) in the pin.

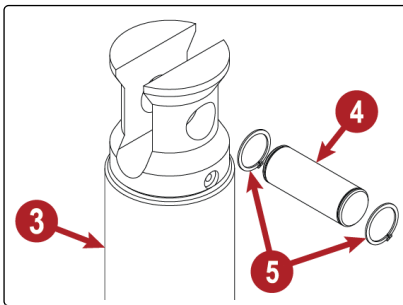

IMPORTANT

Be sure that the swivel is facing up when attaching it to the main winch.

This position allows the main winch cable to freely turn up/down.

If it is not, the swivel will be damaged, and/or the kelly bar eye will bend, causing serious problems to the machine.

6. Tilt the mast (6) completely forward.

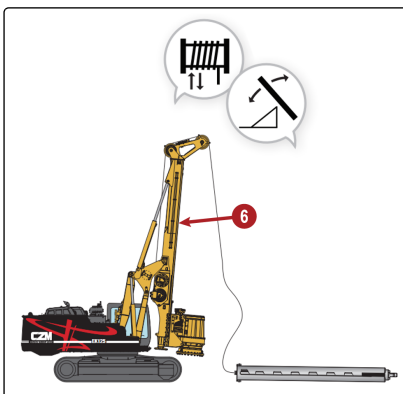

7. Move the machine forward and simultaneously lift the kelly bar with the main winch.

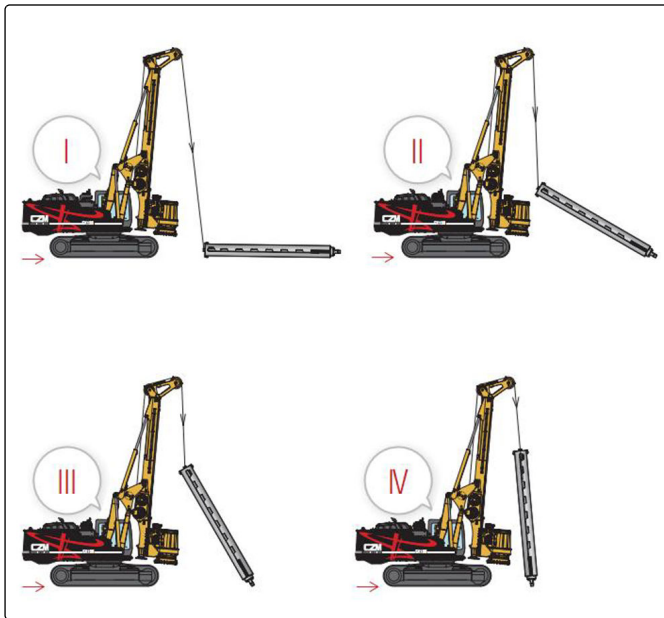

8. Raise the kelly bar to a vertical position.

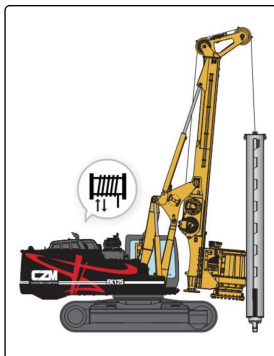

9. Raise the kelly bar to the top of the mast so it clears the top of the rotary.

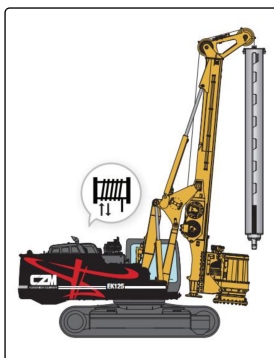

- Position the mast perfectly plumb in both directions, Make sure 0° is indicated for the mast on both the X and Y axis on the display.

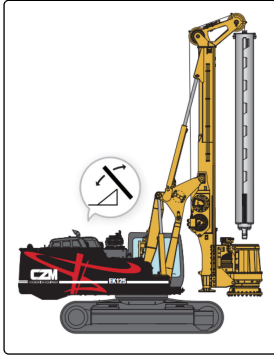

- Attach a guide rope to the kelly bar and have an assistant guide the kelly bar into the rotary.



WARNING

Any person assisting the operator in this phase must:

- Keep fingers and other body parts away from pinch points to prevent crushing injuries while operating the drilling rig.
- Never stand under or allow feet or other body parts under drilling rig components to avoid crushing hazards.
- Remain within the operator’s field of vision when the machine is being moved or operated.
- Understand how to communicate with the operator using standard hand signals.

Failure to follow this warning could result in death or serious injury.



CAUTION

Have an assistant with a rope attached to the kelly bar guide the kelly bar as the rotary is raised. Improper alignment/contact of the kelly bar and rotary can result in machine damage

- Raise the rotary to its top position. Rotate the rotary if needed to align the rotary and kelly bar pads.

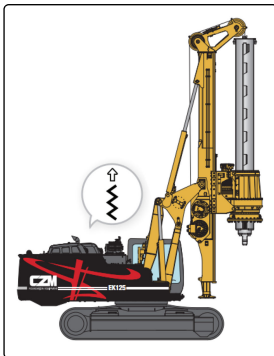

9. DISASSEMBLY

9.1. DISASSEMBLING THE MACHINE'S COMPONENTS



WARNING

Any person assisting the operator in this phase must:

- Keep fingers and other body parts away from pinch points to prevent crushing injuries while operating the drilling rig.
- Never stand under or allow feet or other body parts under drilling rig components to avoid crushing hazards.
- Remain within the operator's field of vision when the machine is being moved or operated.
- Understand how to communicate with the operator using standard hand signals.

Failure to follow this warning could result in death or serious injury.

Some procedures must be done with the drilling rig in motion, with the operator on board, and with help of an assistant who must perform steps directly on the machine.

Follow these steps to disassemble the machine components.



WARNING

Perform these steps in the described order or you risk a tip over.

Failure to follow this warning could result in death or serious injury.

1. [Disassembling the Kelly Bar \(page 335\)](#)
2. [Disassembling the A-Frame \(page 341\)](#)
3. [Disassembling the Swivel \(page 342\)](#)
4. [Disassembling the Rotary \(page 343\)](#)
5. [Disassembling the CZM Counterweight \(Additional\) \(page 344\)](#)
6. [Disassembling the CAT Counterweight \(Main\) \(page 345\)](#)

9.1.1. Disassembling the Kelly Bar

9.1.1.1. Standard Mast Version

1. Place the mast in the transport position.
2. Remove the two square lynch pins (10) securing the lock pins (9) to the A-frame assembly.

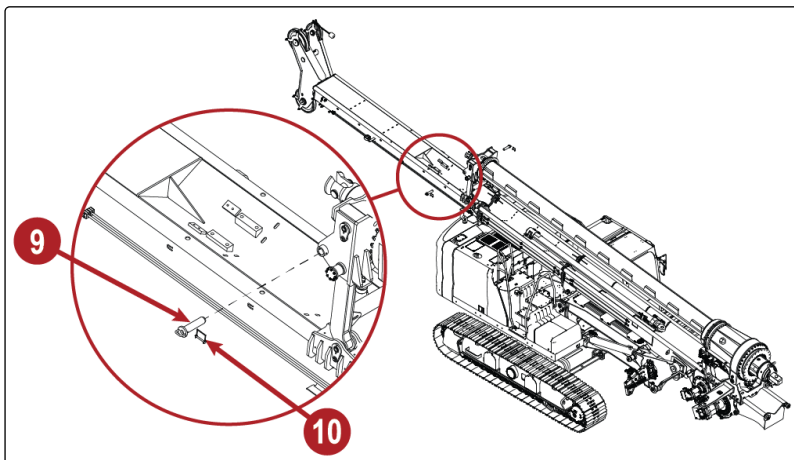

3. Remove the two lock pins from the A-frame assembly.
4. Place the mast back in the vertical operating position.
5. Lower the rotary to its lowest position on the mast.

- Lift the kelly bar (7) slowly above the rotary head (8).

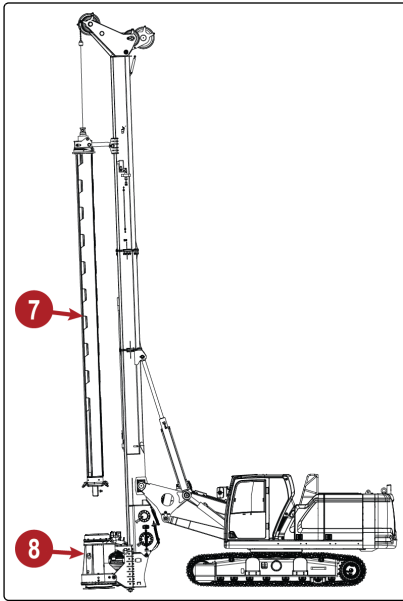

- Lower the kelly bar using the main winch until the bottom of the kelly bar (12) rests on the ground. Tilt the mast forward as needed to keep the kelly bar from contacting the rotary head (13).

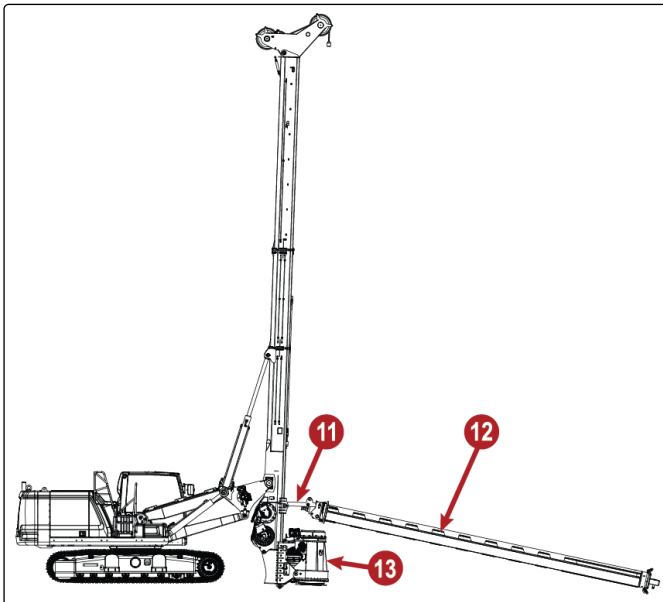

- Slowly back the machine away from the kelly bar as it is being lowered until the A-frame (11) is above the rotary head.
- Use the auxiliary winch to support the A-frame.

10. Remove the bolt and washer (5), snap ring (6). Remove the pivot pin (4) securing the foot (3) to the A-frame assembly. Only one of the A-frame feet needs to be removed.

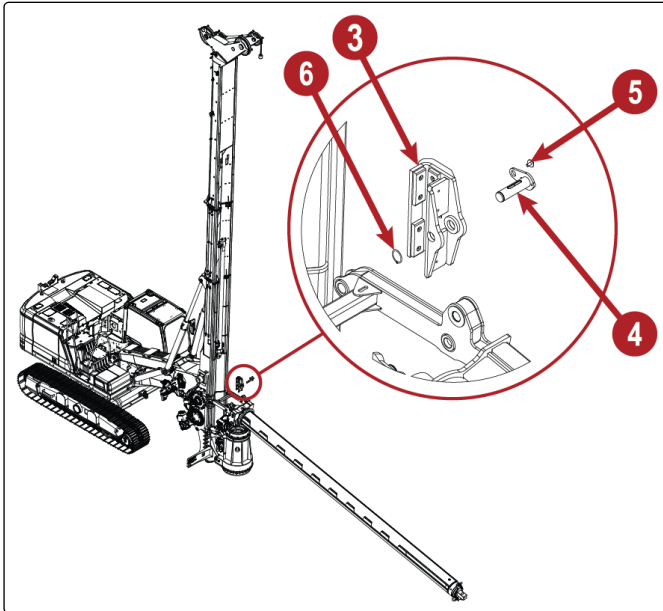

11. Pull the remaining A-frame foot away from the mast.
12. Use the main winch to lower the kelly bar to the ground.
13. Turn off the bottom-hole system to allow the main winch cable to be unwound without any tension on the cable.
See [Section: "L3—Main Winch Bottom Hole Exclusion Switch" \(page 219\)](#) for more information.
14. Place wood support blocks (14) under the kelly bar (15) as it is lowered. Move the machine away from the kelly bar so it clears the machine.

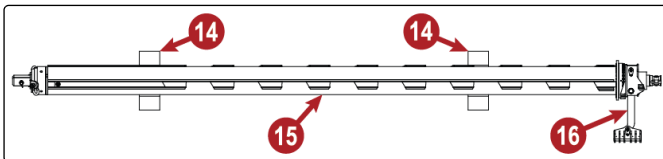

15. After the kelly bar is lowered and fully supported on wood blocks, disconnect the main winch cable from the swivel.
16. Remove the A-frame (16). See [Section: "Disassembling the A-Frame" \(page 341\)](#) for more information.

9.1.1.2. Short Mast Version



CAUTION

Do not excessively raise the kelly bar to prevent it from hitting the head mast or damaging the main winch wire rope.

1. Raise the kelly bar to the top of the mast.

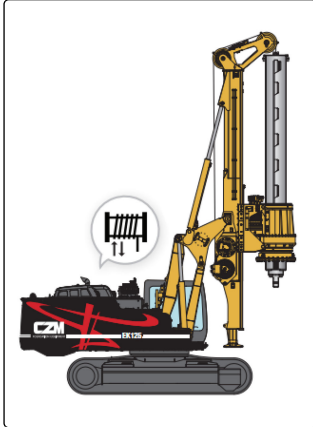

2. Lower the rotary so it is clear of the kelly bar.

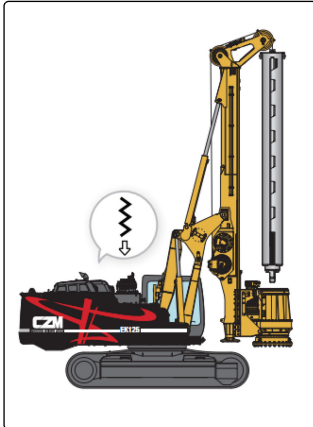

3. Tilt the mast forward as far as possible.

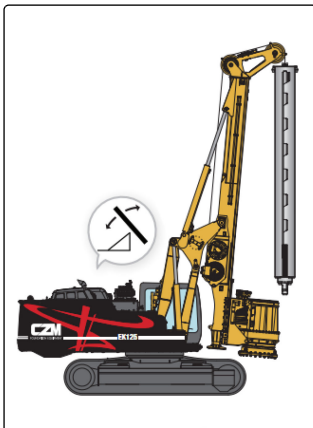

4. Lower the kelly bar to the ground.

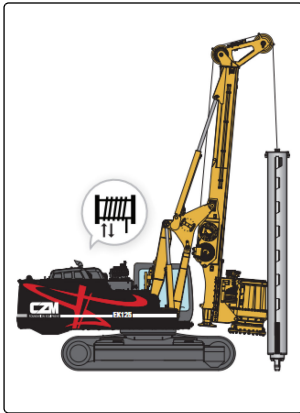

5. Move the machine backward while lowering the kelly bar.

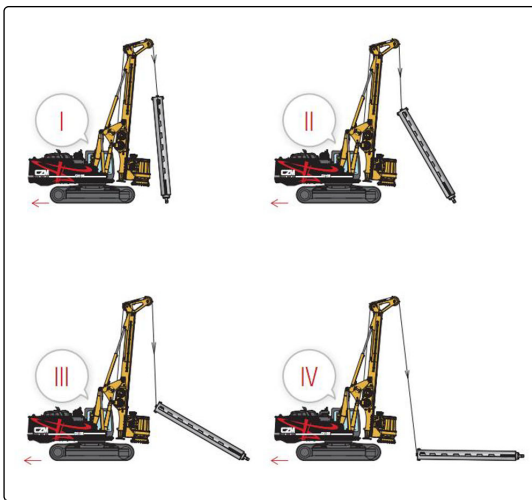

6. Turn off the bottom-hole system to allow the main winch cable to be unwound without any tension on the cable.

See [Section: "L3–Main Winch Bottom Hole Exclusion Switch" \(page 219\)](#) for more information.

7. Lower the kelly bar in the ground.
8. Unwind the main winch to release the tension on the wire rope.

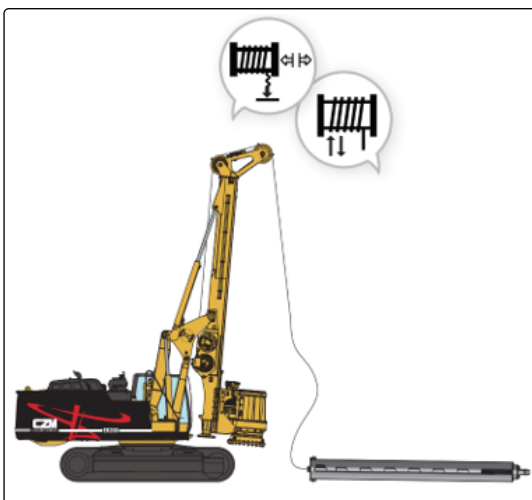

9. Remove the retaining rings (5) and pin (4) that lock the wire rope thimble in the kelly bar swivel (3).

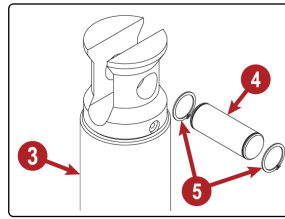

10. Return the mast to the vertical position and wind up the wire rope to a safe height.

9.1.2. Disassembling the A-Frame



IMPORTANT

Use two wood blocks with a half-round cut in the center to cradle the kelly bar for support. Make sure the kelly bar does not move during this procedure.

1. Remove the kelly bar with the A-frame.
See [Section: "Standard Mast Version" \(page 335\)](#) for more information.
2. With the assistance of a crane that supports the load of the kelly bar (2), or using the main winch, lay the kelly bar on the wood supports (1).
3. Position the A-frame (3) next to the kelly bar so that the A-frame is sideways and resting on the ground.
4. Support the A-frame with the auxiliary winch.
5. After making sure the kelly bar is supported and cannot move, remove the main winch cable from the swivel (4).
6. Remove all of the outer bolts (6), which connect the bearing (5) to the kelly bar.
7. After ensuring both parts are correctly unbolted, carefully move the A-frame until it is clear of the swivel.

Figure 221.

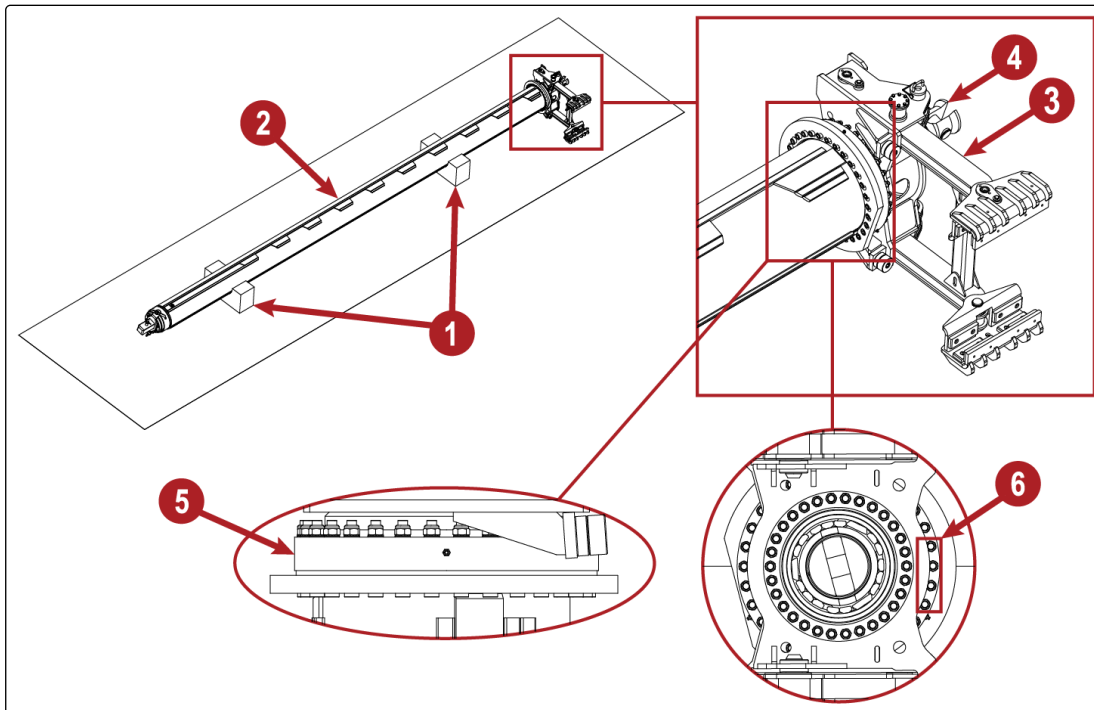

0000270 Disassembly-A-Frame

9.1.3. Disassembling the Swivel

1. Prepare the machine for service. For more information refer to *Prepare the Machine for Maintenance** (page 384).
2. Remove the kelly bar from the machine. See *Disassembling the Kelly Bar* (page 335) for more information.
3. Rotate the swivel (1) so that the swivel mounting pin can be accessed from the access hole in the kelly bar.
4. Remove one of the snap rings (3) securing the swivel pin (2).
5. Remove the swivel pin and swivel.

Figure 222.

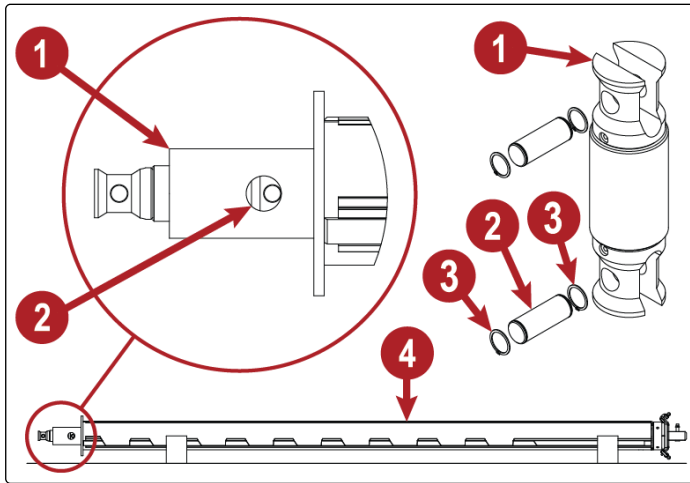

0000365 Assembly-Swivel

Pos.	Description	Qty
1	Swivel	1
2	Swivel Pin	2
3	Snap Ring	4
4	Kelly Bar	1

9.1.4. Disassembling the Rotary

1. Place the mast in the vertical operating position (leveled).
2. Ensure that the bottom mast is extended and touching the ground.
3. Lower the rotary to its lowest position on the mast.
4. Slide the rotary off the mast by following one of the procedures below.

With the use of a forklift:

- a. Support the rotary with a forklift.
- b. Remove the mast lock assemblies from both sides of the foot mast.

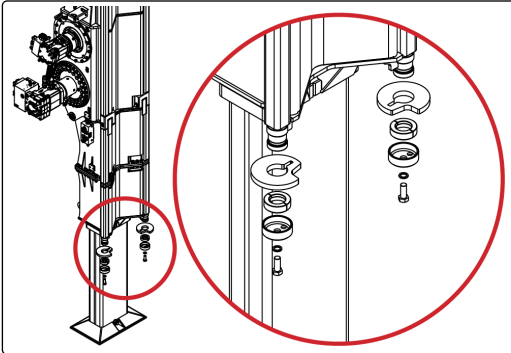

- c. Remove the lock bolt and crowd cylinder rod pin to disconnect the crowd cylinder from the rotary. If necessary, slightly move the crowd cylinder to facilitate the removal of the pin.

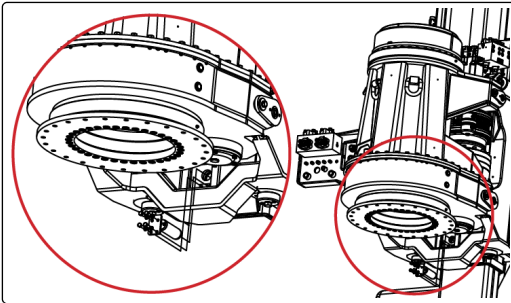

- d. Use the forklift to lower the rotary until the mast is above the rotary.

If a forklift is not available:

- a. Lower the mast as low as possible. Use wood blocking to support the rotary head off the ground. The bottom mast must be fully retracted.
- b. Remove the mast lock assemblies from both sides of the foot mast.

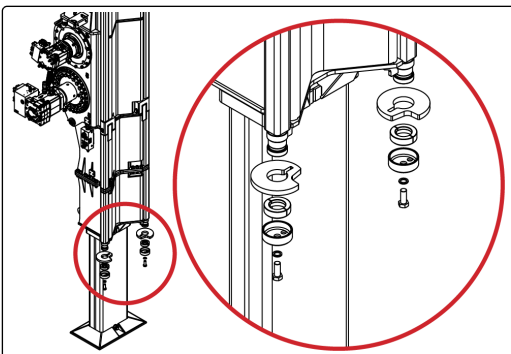

- c. Remove the lock bolt and crowd cylinder rod pin to disconnect the crowd cylinder from the rotary. If necessary, slightly move the crowd cylinder to facilitate the removal of the pin.

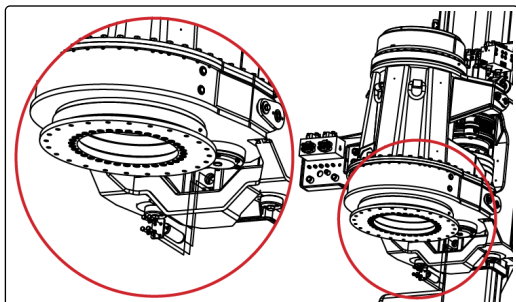

- d. Slowly raise the mast and at the same time move the machine forward until the mast is above the rotary. Maintain the “auto-tilt” function activated throughout this step to ensure that the mast remains vertical.

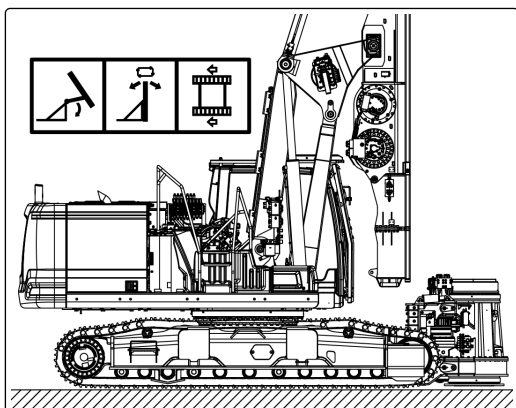

5. Tag and disconnect the hydraulic lines to the rotary sled manifold. Cap and plug all open hydraulic lines and fittings.

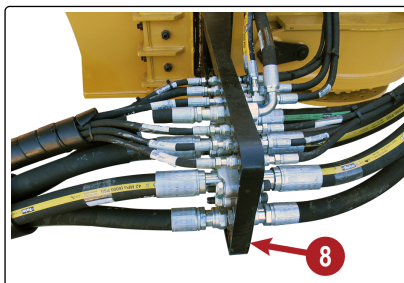

6. Disconnect electrical connectors to the rotary head.

9.1.5. Disassembling the CZM Counterweight (Additional)



WARNING

- When the counterweight is removed, the stability of the machine is decreased.
- The mast must be facing forward, to the front of the machine.
- The tracks must be extended when removing and installing the counterweight.

Avoid any sudden movements or actions that may cause the machine to tip over. Failure to follow this warning could result in death or serious injury.

1. Prepare the machine for service. For more information refer to *Prepare the Machine for Maintenance** (page 384).
2. Remove the kelly bar from the machine. See *Disassembling the Kelly Bar* (page 335) for more information.
3. Extend the tracks. See *Extend the Undercarriage Tracks* (page 297) for more information.
4. If the mast is in the transport position, raise it to provide adequate clearance above the counterweight.

5. **! DANGER**
 During this operation, the Technician must get under the counterweight to install/remove the connecting bolts, while the counterweight will remain hanged to the lifting device above him.
 It is extremely important to verify that the lifting device and its straps/chains are rated for the weight to be lifted and that they are not damaged.
 Failure to follow this warning will cause serious injury or death.

Attach a lifting device to the CZM counterweight (1) using the two lifting lugs (2) on top. The CZM counterweight weighs 1,300 lbs (600 kg).

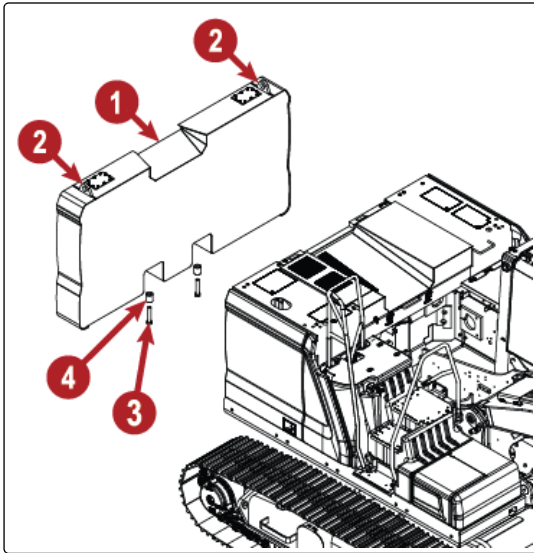

6. Remove 2 spacers (4) and 2 bolts (3) from the CZM counterweight.

- ! DANGER**
 Do not swing or travel the machine without the counterweight bolts installed.
 Failure to follow this warning will cause serious injury or death.

7. Remove the CZM counterweight from the machine.

9.1.6. Disassembling the CAT Counterweight (Main)

- ! WARNING**
- When the counterweight is removed, the stability of the machine is decreased.
 - The mast must be facing forward, to the front of the machine.
 - The tracks must be extended when removing and installing the counterweight.
- Avoid any sudden movements or actions that may cause the machine to tip over.
 Failure to follow this warning could result in death or serious injury.

1. Prepare the machine for service. For more information refer to *Prepare the Machine for Maintenance** (page 384).
2. Remove the kelly bar from the machine. See *Disassembling the Kelly Bar* (page 335) for more information.
3. Extend the tracks. See *Extend the Undercarriage Tracks* (page 297) for more information.
4. If the mast is in the transport position, raise it to provide adequate clearance above the counterweight.
5. Disconnect the camera connector (10) from the left side compartment near the radiator and condenser (9).

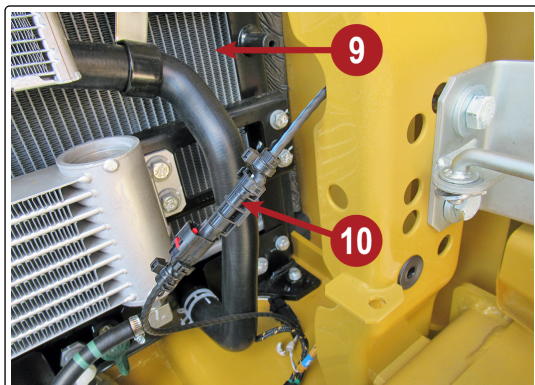

6. If required, install two lifting eye bolts (M42 x 4.5) to the CAT counterweight.
7. Attach a suitable lifting device to the CAT counterweight. The CAT counterweight weighs 11,880 lbs (5.400 kg).
8. Remove four bolts and spacers (8) securing the CAT counterweight.

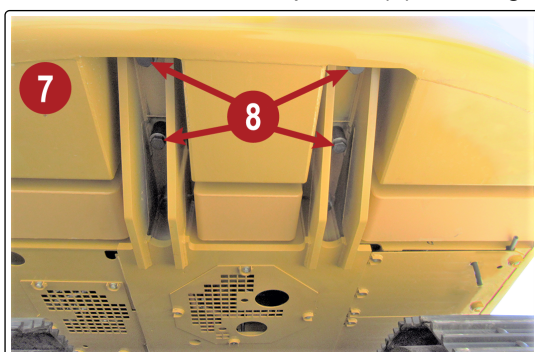

9. Remove the CAT counterweight from the machine.

10. CONVERSIONS

10.1. COMPONENTS' WEIGHTS



WARNING

Use a suitable lifting device for handling heavy objects (more than 25 kg). If you use a crane, it must be operated by a qualified operator.

Table 59. Standard Mast Components (Kit Code: 20860.0396.000)

Description	Weight
Mast Extension Subassembly	980.4 lb (444,7 kg)
Upper Mast Subassembly	1,684.8 lb (764,2 kg)
Mast Head Subassembly	1,142.4 lb (518,2 kg)
Crowd Cylinder Subassembly	1,025.6 lb (465 kg)
A-Frame Subassembly	705.7 lb (320,1 kg)
Cable 24mm x 225' / 55mm eye	432 lb (196 kg)
Wiring Harness	N/A

Table 60. Short Mast Components (Kit Code: 20860.0395.000)

Description	Weight
Mast Head Subassembly	1,491.4 lb (676,5 kg)
Crowd Cylinder Subassembly	900 lb (408,3 kg)
Cable 24mm x 105' / 55mm eye	203 lb (92 kg)
Wiring Harness	N/A

10.2. FROM STANDARD TO SHORT MAST



WARNING

Any person assisting the operator in this phase must:

- Keep fingers and other body parts away from pinch points to prevent crushing injuries while operating the drilling rig.
- Never stand under or allow feet or other body parts under drilling rig components to avoid crushing hazards.
- Remain within the operator's field of vision when the machine is being moved or operated.
- Understand how to communicate with the operator using standard hand signals.

Failure to follow this warning could result in death or serious injury.



WARNING

Perform these steps in the described order or you risk a tip over.

Failure to follow this warning could result in death or serious injury.

Before starting this procedure, remove these components in the following order:

1. Work tool (see [Disconnect the Work Tool \(page 361\)](#)).
2. Kelly bar (see [Disassembling the Kelly Bar \(page 335\)](#)).
3. A-Frame (see [Disassembling the A-Frame \(page 341\)](#)).
4. Swivel (see [Disassembling the Swivel \(page 342\)](#)).
5. Rotary (see [Disassembling the Rotary \(page 343\)](#)).

Follow these steps to convert the machine:

1. Completely remove the main winch cable. See [Replacing the Winch Wire Rope \(page 506\)](#).
2. Remove the auxiliary winch cable from the mast head.
3. Release the hydraulic system pressure. See [Releasing of Hydraulic Pressure from the Main Hydraulic System* \(page 450\)](#).
4. Place the machine in the transport position. Do not operate the mast head and crowd cylinder to prevent re-pressurization of hydraulic lines. The mast head must remain in the operating position, and the crowd cylinder must be retracted.

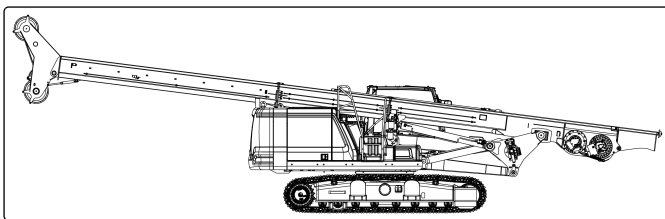

5. Shut off the engine.
6. Tag and disconnect all electrical, hydraulic, and lubricating connections between the mast and the base of the machine. Cap and plug all open hydraulic lines and fittings.

The location of the connections can be seen below. Connections include:

- Hydraulic lines to the mast head cylinder.
- Hydraulic lines to the crowd cylinder.
- Electrical connections to winch limit sensors. Winch limit sensors can be found on the mast head, near the winch cable rollers.
- Electrical lines to upper mast lights.
- Hydraulic lines to A-frame detent.

Note: Ensure connections between the mast head, upper mast, and mast extension are disconnected if mast components are removed separately.

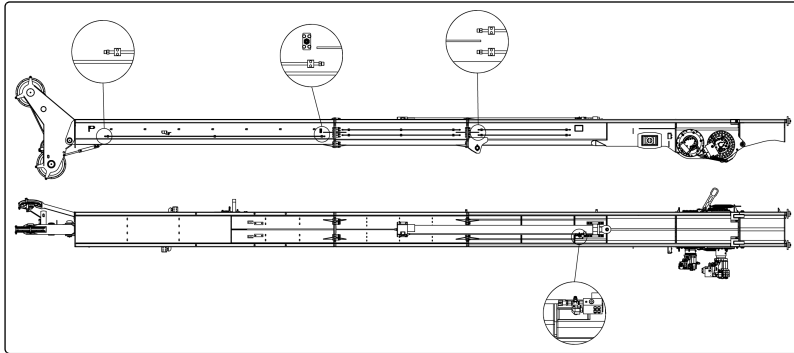

7. Disconnect the crowd cylinder from the mast.

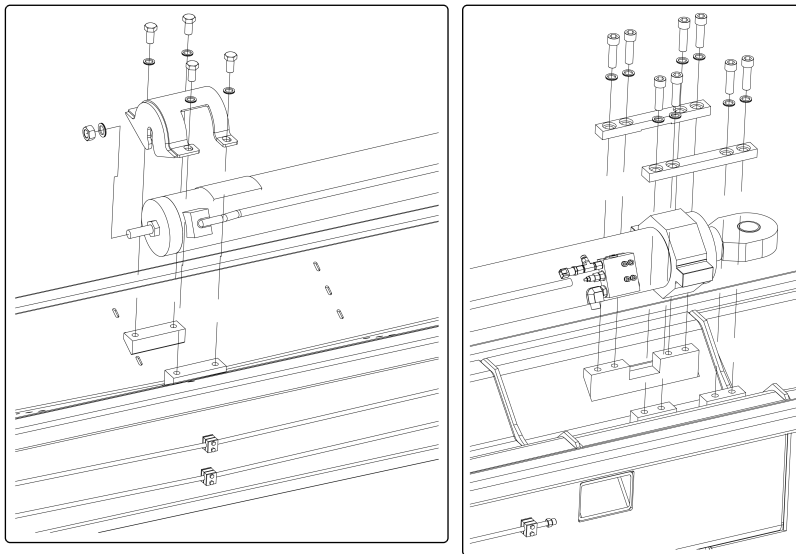

8. Use an appropriate lifting device to remove the crowd cylinder. Attach two lifting points to the ends of the components and beware of the center of gravity of the components.

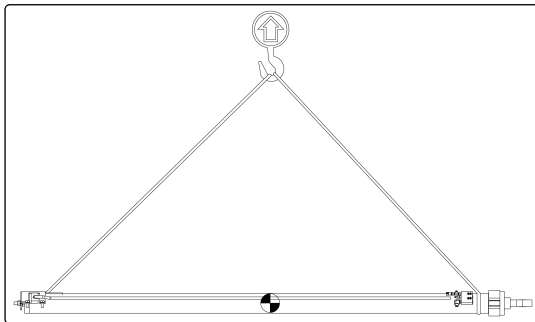

9. Hook the long mast assembly (head mast, upper mast, and mast extension) with an appropriate lifting device. Beware of the center of gravity.

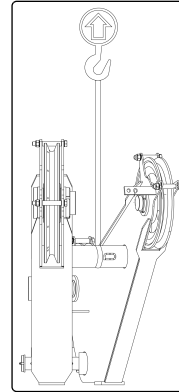
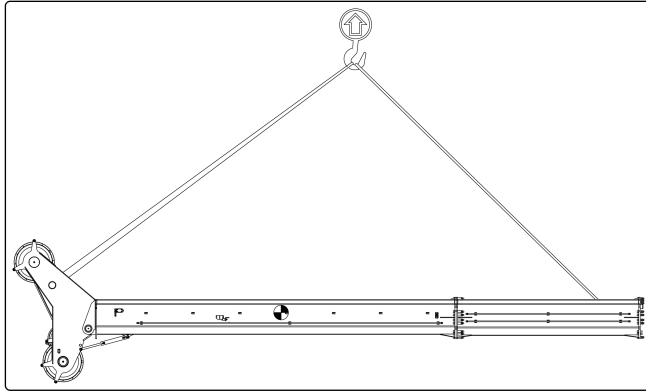

10. Disconnect the mast extension from the main mast.

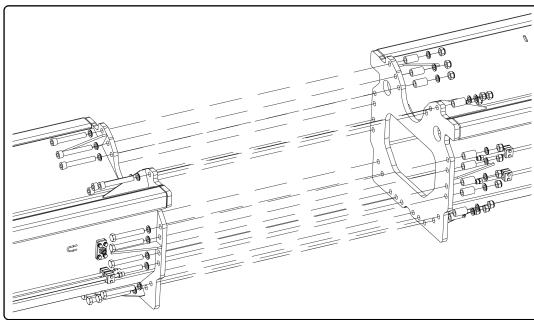

11. Remove the long mast assembly (head mast, upper mast, and mast extension).

Note: If preferred, the mast extension, upper mast, and head mast may be removed separately.

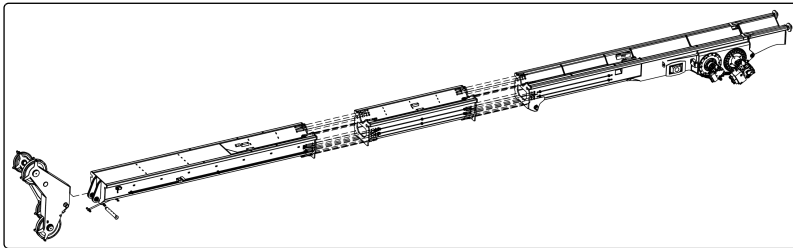

IMPORTANT

The mast head, upper mast, mast extension, crowd cylinder, and main winch cable are specific to the long mast version of the machine.

These components must not be used with a short mast.

12. Use an appropriate lifting device to install the short mast components on the machine. Install the mast head (1), and crowd cylinder (2).

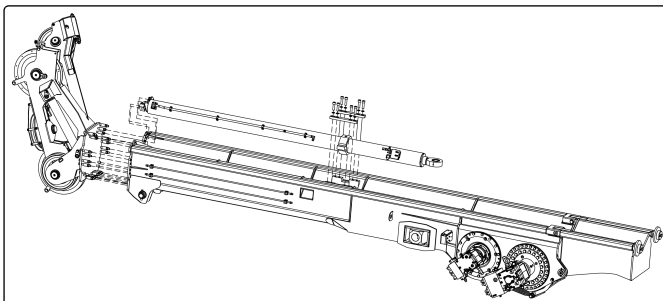

13. Connect all electrical, hydraulic, and lubricating connections between the mast assembly and the base of the machine. Ensure that all connections are properly fitted before starting the engine. These include:
 - Hydraulic lines to the mast head cylinder.
 - Hydraulic lines to the crowd cylinder.
 - Electrical lines to winch limit sensors. Winch limit sensors can be found on the mast head, near the winch cable rollers.

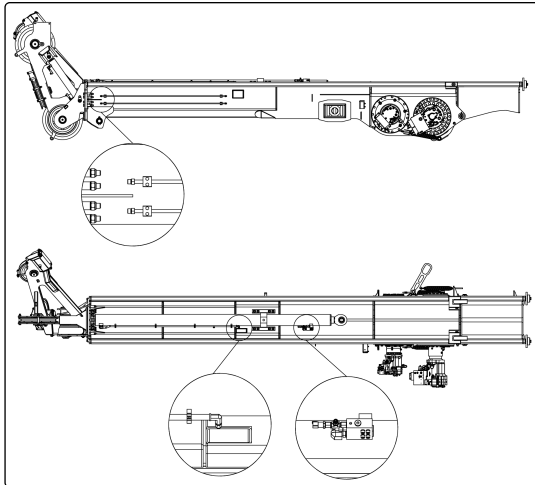

14. Install the main winch cable and auxiliary winch cable. See [Replacing the Winch Wire Rope \(page 506\)](#).
15. Install the following components:
 - a. Rotary (see [Rotary \(page 324\)](#)).
 - b. Kelly Bar (see [Kelly Bar \(page 328\)](#)).
 - c. Work Tool (see [Connect the Work Tool \(page 301\)](#)).
16. Reconfigure the CZM Monitor to short mast settings. Follow the procedure below:
 - a. With the mast in the vertical position, raise the Kelly bar until the limit switch prevents any further movement (full-up position).
 - b. Count the number of layers of cable on the main winch drum. Record this value.
 - c. Count the number of times the cable wraps around the main winch drum on the last layer. Record this value.
 - d. Go to the settings screen of the CZM Monitor. See [Settings Screen \(page 229\)](#).

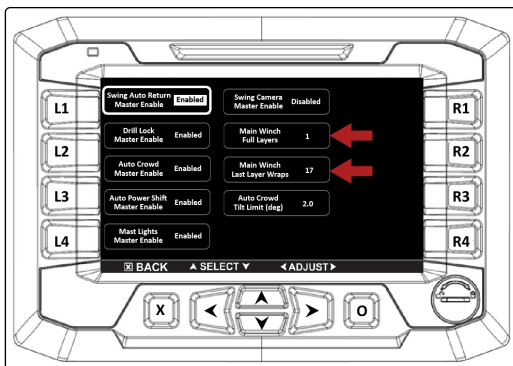

- e. Set the value of “Main Winch Full Layers” to the value recorded in point "b" of this procedure.
 - f. Set the value of “Main Winch Last Layer Wraps” to the value recorded in point "c" of this procedure.
 - g. With the Kelly bar still in full-up position. Return to the home screen. Press and hold the “Zero the Depth” switch. See [Home Screen Switch Functions \(page 212\)](#).
17. Test and verify that drilling functions are working as expected.

10.3. FROM SHORT TO STANDARD MAST



WARNING

Any person assisting the operator in this phase must:

- Keep fingers and other body parts away from pinch points to prevent crushing injuries while operating the drilling rig.
- Never stand under or allow feet or other body parts under drilling rig components to avoid crushing hazards.
- Remain within the operator's field of vision when the machine is being moved or operated.
- Understand how to communicate with the operator using standard hand signals.

Failure to follow this warning could result in death or serious injury.



WARNING

Perform these steps in the described order or you risk a tip over.

Failure to follow this warning could result in death or serious injury.

Before starting this procedure, remove these components in the following order:

1. Work tool (see [Disconnect the Work Tool \(page 361\)](#)).
2. Kelly bar (see [Disassembling the Kelly Bar \(page 335\)](#)).
3. Rotary (see [Disassembling the Rotary \(page 343\)](#)).

Follow these steps to convert the machine:

1. Completely remove the main winch cable. See [Replacing the Winch Wire Rope \(page 506\)](#).
2. Remove the auxiliary winch cable from the mast head.
3. Release the hydraulic system pressure. See [Releasing of Hydraulic Pressure from the Main Hydraulic System* \(page 450\)](#).
4. Place the machine in the transport position. Do not operate the mast head and crowd cylinder to prevent re-pressurization of hydraulic lines. The mast head must remain in the operating position, and the crowd cylinder must be retracted.

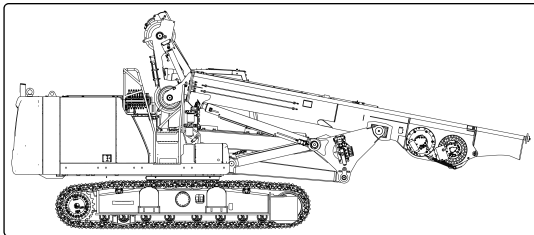

5. Shut off the engine.
6. Tag and disconnect all electrical, hydraulic, and lubricating connections between the mast and the base of the machine. Cap and plug all open hydraulic lines and fittings.

The location of the connections can be seen below. Connections include:

- Hydraulic lines to the mast head cylinder.
- Hydraulic lines to the crowd cylinder.
- Electrical connections to winch limit sensors. Winch limit sensors can be found on the mast head, near the winch cable rollers.

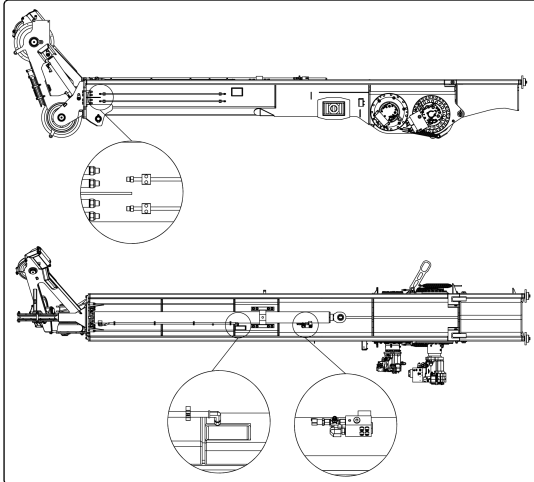

7. Hook the mast head with an appropriate lifting device.

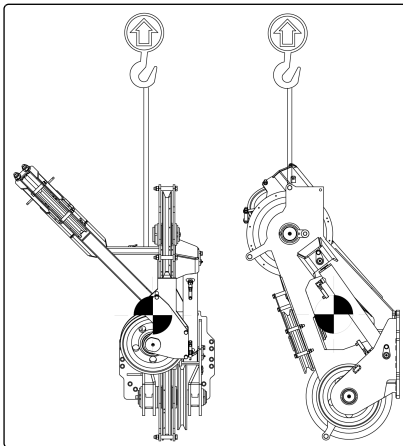

8. Remove the connection bolts between the mast head and the mast.

! **IMPORTANT**
The front bolts hold both the mast head and the cylinder's upper bracket.

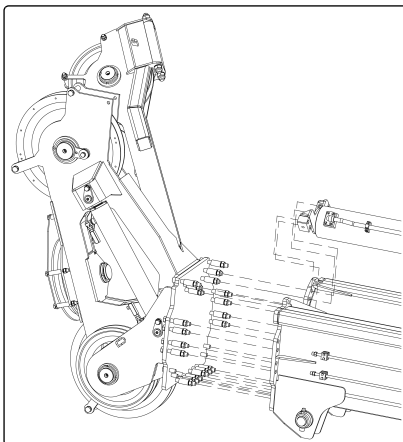

9. Remove the mast head.
10. Remove the lower bracket of the crowd cylinder.

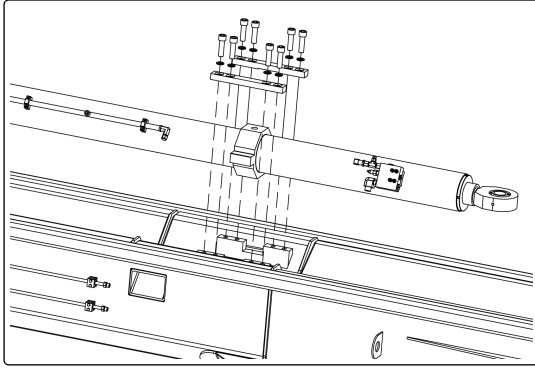

11. Use an appropriate lifting device to remove the crowd cylinder. Attach two lifting points to the ends of the components and beware of the center of gravity of the components.

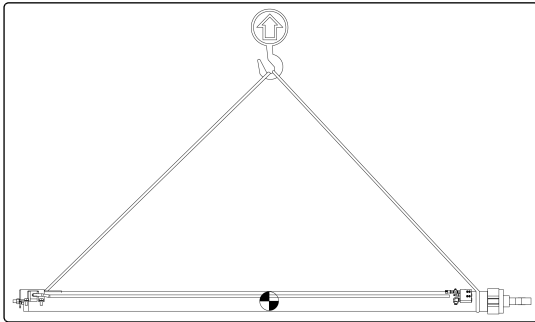

IMPORTANT

The mast head, crowd cylinder, and main winch cable are specific to the short mast version of the machine.

These components must not be used with a standard mast.

12. Pre-assemble the mast head, upper mast, and mast extension.

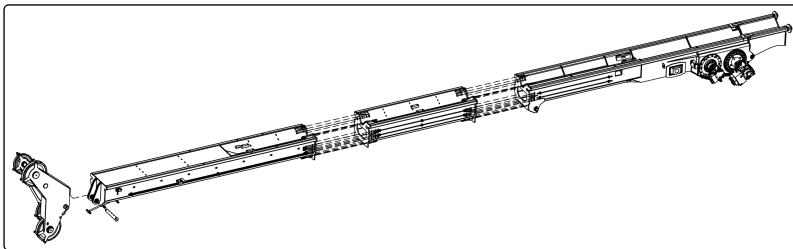

13. Hook the long mast assembly (head mast, upper mast, and mast extension) with an appropriate lifting device. Beware of the center of gravity.

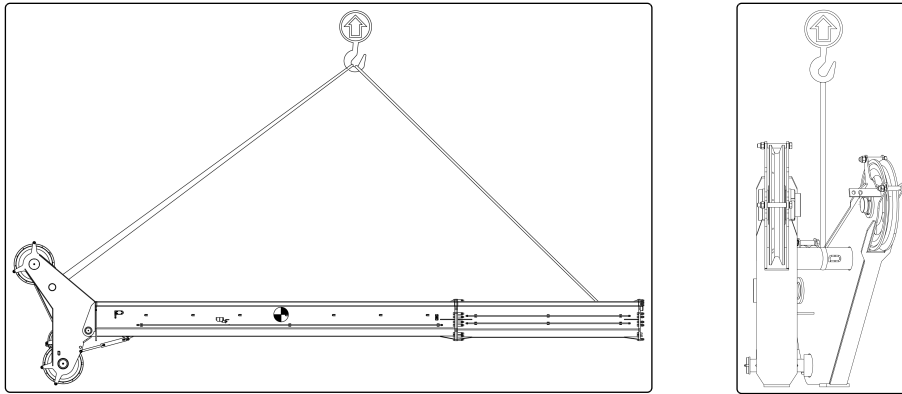

14. Install the long mast assembly on the main mast.

Note: If preferred, the mast extension, upper mast, and head mast may be installed separately.

15. Install the crowd cylinder.

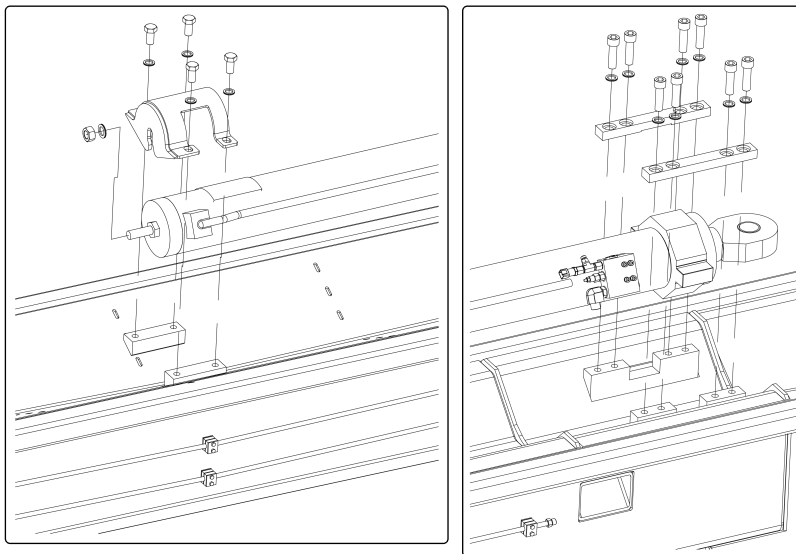

16. Connect all electrical, hydraulic, and lubricating connections between the mast assembly and the base of the machine. Ensure that all connections are properly fitted before starting the engine. These include:

- Hydraulic lines to the mast head cylinder.
- Hydraulic lines to the crowd cylinder.
- Hydraulic lines to A-frame detent.
- Electrical lines to upper mast lights.
- Electrical lines to winch limit sensors. Winch limit sensors can be found on the mast head, near the winch cable rollers.

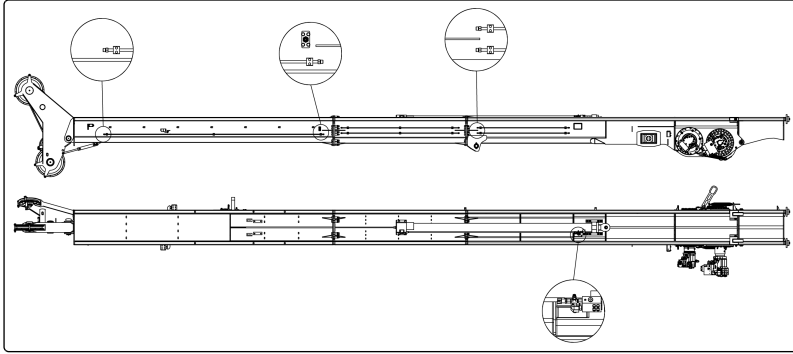

17. Install the main winch cable and auxiliary winch cable. See [Replacing the Winch Wire Rope \(page 506\)](#).
18. Install the following components:
 - a. Rotary (see [Rotary \(page 324\)](#)).
 - b. Swivel (see [Swivel \(page 326\)](#)).
 - c. A-Frame (see [A-Frame \(page 327\)](#)).
 - d. Kelly Bar (see [Kelly Bar \(page 328\)](#)).
 - e. Work Tool (see [Connect the Work Tool \(page 301\)](#)).
19. Reconfigure the CZM Monitor to short mast settings. Follow the procedure below:
 - a. With the mast in the vertical position, raise the Kelly bar until the limit switch prevents any further movement (full-up position).
 - b. Count the number of layers of cable on the main winch drum. Record this value.
 - c. Count the number of times the cable wraps around the main winch drum on the last layer. Record this value.
 - d. Go to the settings screen of the CZM Monitor. See [Settings Screen \(page 229\)](#).

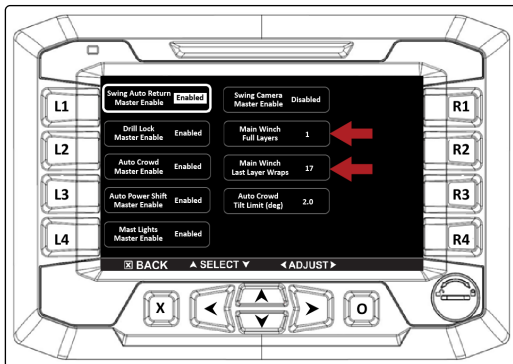

- e. Set the value of “Main Winch Full Layers” to the value recorded in point “b” of this procedure.
- f. Set the value of “Main Winch Last Layer Wraps” to the value recorded in point “c” of this procedure.
- g. With the Kelly bar still in full-up position. Return to the home screen. Press and hold the “Zero the Depth” switch. See [Home Screen Switch Functions \(page 212\)](#).
20. Test and verify that drilling functions are working as expected.

This page is intentionally left blank.

11. TRANSPORTATION

11.1. MACHINE SETUP FOR TRANSPORTATION



WARNING

Any person assisting the operator in this phase must:

- Keep fingers and other body parts away from pinch points to prevent crushing injuries while operating the drilling rig.
- Never stand under or allow feet or other body parts under drilling rig components to avoid crushing hazards.
- Remain within the operator's field of vision when the machine is being moved or operated.
- Understand how to communicate with the operator using standard hand signals.

Failure to follow this warning could result in death or serious injury.

Some procedures must be done with the drilling rig in motion, with the operator on board, and with help of an assistant who must perform steps directly on the machine.



WARNING

Perform these steps in the described order or you risk a tip over.

Failure to follow this warning could result in death or serious injury.

The main steps for transport setup are:

1. *Disconnect the Work Tool (page 361)*
2. *Disassembling the Kelly Bar (page 335)*
3. *Place the Mast in the Transport Position (page 363)*
4. *Retract the Undercarriage Tracks (page 369)*

11.2. DISCONNECT THE WORK TOOL

1. Lower the kelly bar until the work tool touches the ground.

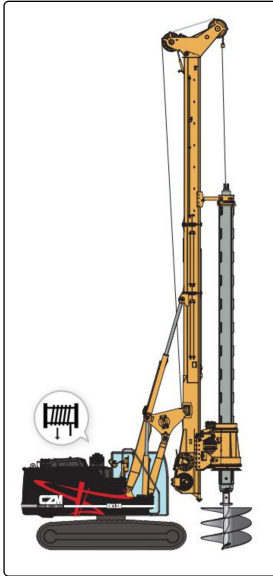

2. Remove the safety pin (7), washer (8), and pin (9) that secure the work tool to the kelly bar.

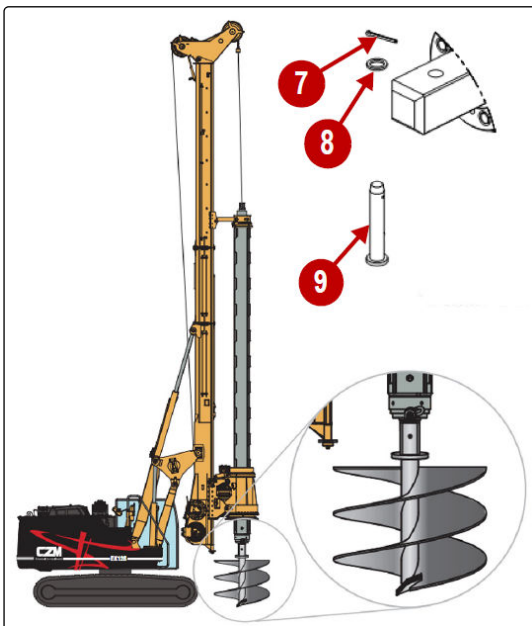

3. If the work tool is possibly unstable, add support to prevent tipping when the kelly bar is removed.



WARNING

Make sure any assistant helping to disconnect the work tool has left the danger zone before raising the kelly bar.

There is a risk of the work tool falling over resulting in death or severe injury.

4. Make sure all personnel are clear of the work area danger zone.

5. Slowly lift the Kelly bar to release the work tool.

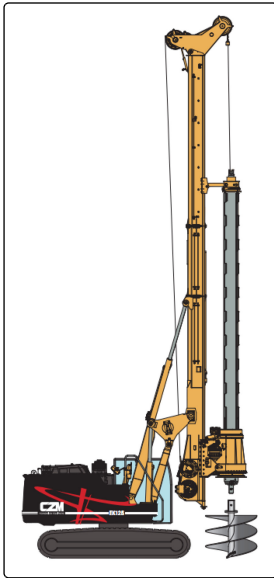

6. Move the machine backward away from the work tool.

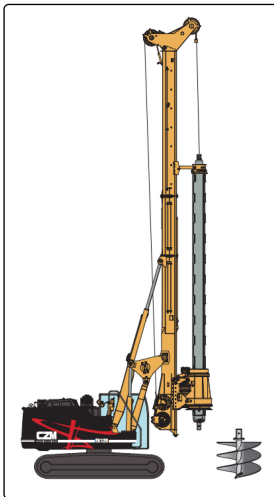

11.3. PLACE THE MAST IN THE TRANSPORT POSITION

1. Temporarily lower the mast to place it in the transport position.
2. Remove two snap rings and remove two lock pins from the A-frame while the mast is in the transport position.
3. Raise the mast to the upright position to place it in the work position. For more information refer to [Section: "Place the Mast in the Work Position" \(page 298\)](#).
4. Raise the kelly bar (1) so the A-frame (2) is positioned just above the mast detent (3). The rotary (4) must be positioned on the bottom part of the kelly bar.

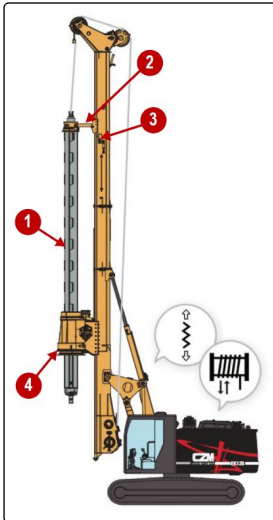

WARNING

Do not allow the kelly bar to leave the rotary.
The free-swinging of the kelly bar may cause death, severe injury, and damage to the machine.

5. Tilt the mast back to approximately 30°. Lower the parallelogram (5) simultaneously as needed to keep the machine stable.



- On the monitor, press the up arrow button (6) from the main screen to display the settings options.

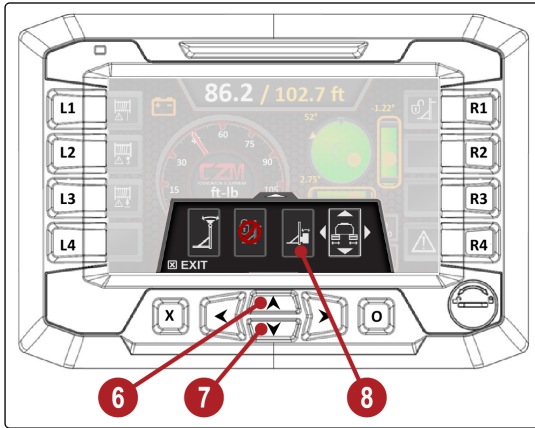

- Select the rotary tilt option (8).
- When selected, the rotary function will display four arrows.

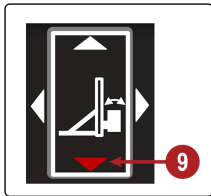

- Use the down arrow button (7) or touch near the down arrow (9) on the display to move the rotary tilt cylinders to a transport position.
- Select the A-frame detent arm lock function (10).

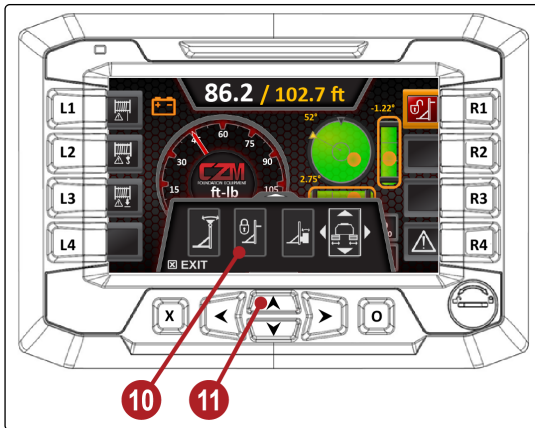

- When selected, the A-frame detent arm lock function will display four arrows.
- Use the up arrow button (11) or touch near the up arrow (12) on the display to place the detent arm in the locked position.

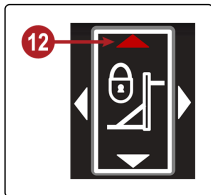

13. Slowly lower the rotary, dragging the kelly bar with it (do not interlock) to release the A-frame detents and place the kelly bar in the transport position.

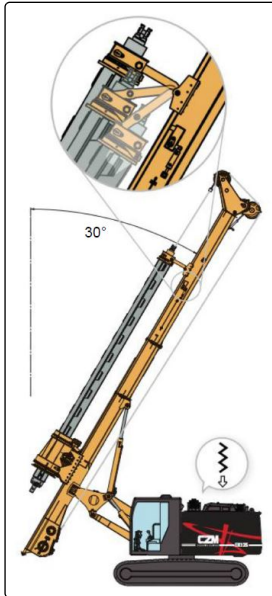

WARNING

Stop lowering the rotary immediately after the kelly bar is lowered into its transport position on the mast to prevent damage to the A-frame and detent mechanism.

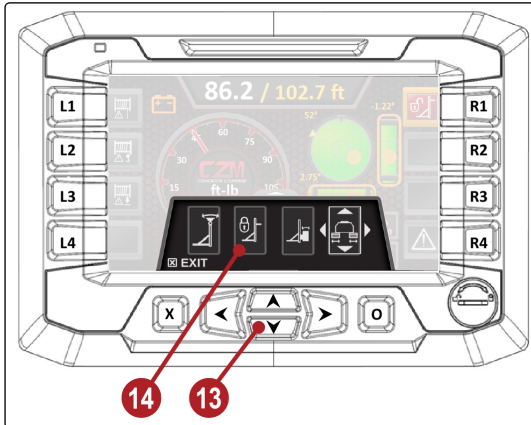
14. On the monitor, select the A-frame detent arm lock function (14).

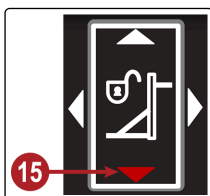

15. Use the down arrow button (13) or touch near the down arrow (15) on the display to place the A-frame detent arm in the unlocked position.



16. Attach the supplied chains of the appropriate length through the D-ring and secure them to the transport plate. Make sure to leave two chain links at the end of the chain where you place the hook.
17. Lower the kelly bar and the rotary until the main winch cable tension is released and is slightly slacked.

18. At this time, release the tension on the auxiliary winch cable slightly so there is some slack on this cable as well.
19. Make sure the parallelogram to the mast connection (16) is above the height of the cab. Reposition the parallelogram as needed.

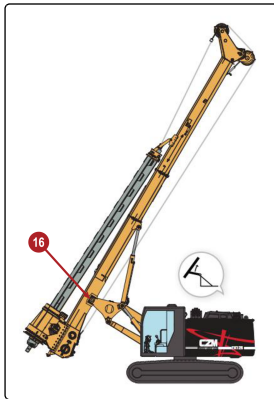

20. Tilt the mast backward. While lowering, make sure it is aligned with the chassis by operating both mast-tilting levers at the same time. Use an individual mast tilt lever to adjust the alignment as needed.

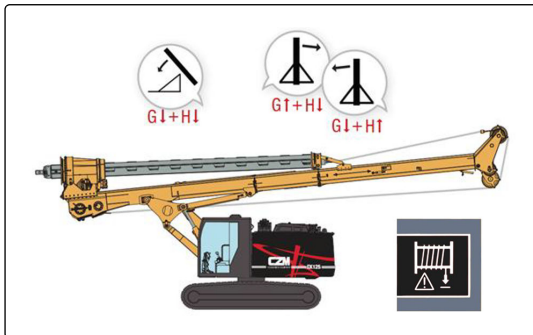

21. Disengage the bottom hole system to allow the main winch to be used without tension on the wire rope. For more information refer to [L3–Main Winch Bottom Hole Exclusion Switch \(page 219\)](#).
22. Release the tension on the main winch cable.



CAUTION

- Make sure nothing is blocking the downward travel of the mast.
- Make sure the mast is aligned with the machine during this procedure to avoid contact with the cab or base manifold.
- Have an assistant shall watch the steel cables to prevent the mast from crushing the cables against the counterweight.

23. Using an observer to check clearances, lower the parallelogram.

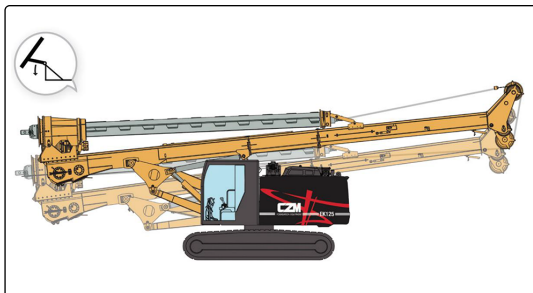

24. On the monitor, press the up arrow button (17) from the main screen to display the settings options.

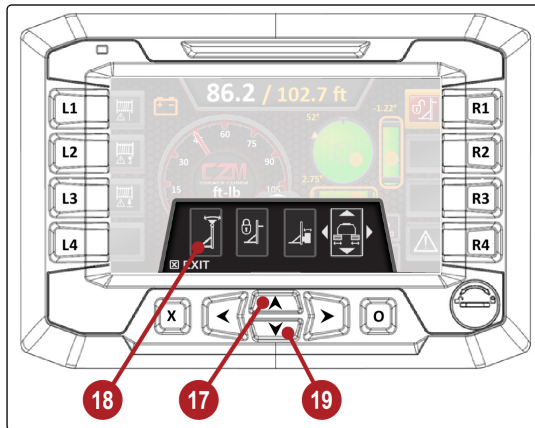

25. Select the head mast fold option.
26. When selected, the head mast fold function will display four arrows.

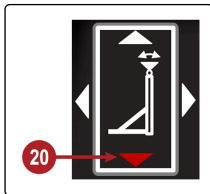

27. Use the down arrow button (19) or touch near the down arrow (20) on the display to rotate the head mast (21) down into a transport position.

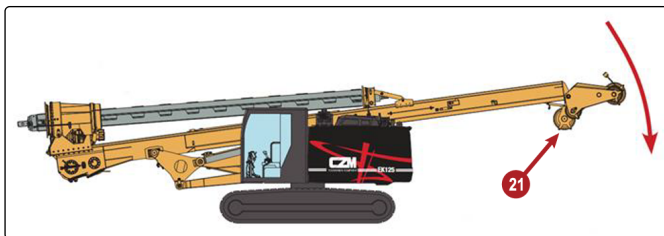

11.4. LOCK THE KELLY BAR

1. Lock the kelly bar on the rotary using the supplied chains (1) and transport plate (2) as shown.
2. Adjust the chain length with the chain hook.

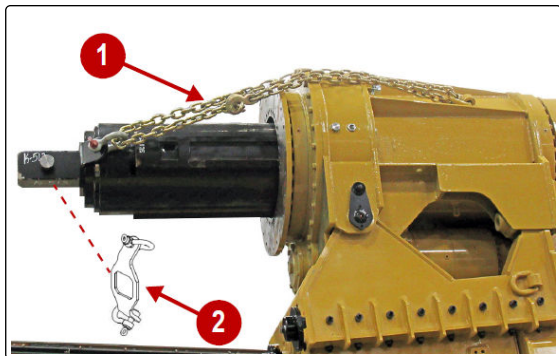

11.5. RETRACT THE UNDERCARRIAGE TRACKS



WARNING

- The undercarriage must be extended or retracted when the mast is in the horizontal position.
- Do not raise the mast if the undercarriage is retracted.
- Do not swing the machine if the undercarriage is retracted.

Failure to follow this warning could result in death or serious injury.
Improper use could result in a tip over.

1. On the CZM Monitor's Second Screen, press the up arrow button (1).
For more information refer to [Section: "Second Screen Settings" \(page 221\)](#).
2. Select the undercarriage option (2).

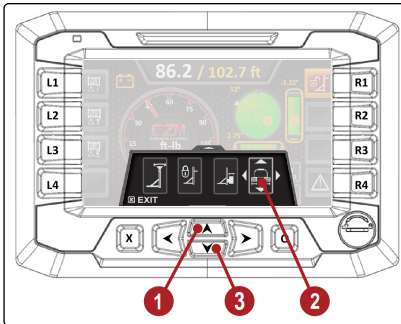

3. When selected, the undercarriage function will display four arrows.
Use the down arrow button (3) or touch near the down arrow (4) on the screen to fully retract the undercarriage tracks.

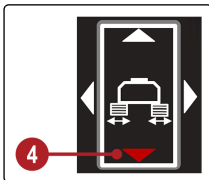

NOTICE

If the soil type hinders operations, travel the undercarriage forward and backward while trying to extend or retract the tracks.



IMPORTANT

Do not over-stress the cylinders, you risk breaking.

11.6. SHIPPING THE MACHINE*

SMCS Code: 7000; 7500

Carefully read and understand what is written in *Personnel* (page 67).



WARNING

Automatic Engine Speed Control (AEC) will increase engine speed automatically when you operate the control levers and/or travel pedals with AEC switch on.

When loading and unloading the machine from the truck or working in close quarters always turn AEC switch off to prevent any possibility of sudden movement of the machine, which could result in serious injury or death.

Set the travel speed control switch to LOW before loading the machine. Never operate this switch when loading the machine on a trailer.

Investigate the travel route for overpass clearances. Make sure that there will be adequate clearance for the machine.

Remove ice, snow, or other slippery material from the loading dock and the truck bed before you load the machine onto the transport machine. Removing ice, snow, or other slippery material will help to prevent the machine from slipping in transit.



IMPORTANT

Obey all laws that govern the load characteristics (height, weight, width, and length).

Observe all regulations that govern wide loads.

Certain regions may require the removal of door hooks and cab bumpers, if equipped. Consult all local and regional regulations

Choose the flattest ground when you load the machine or when you unload the machine.

1. Before you load the machine, chock the trailer wheels or the rail car wheels.
2. When you use loading ramps, make sure that the loading ramps have adequate length, adequate width, adequate strength, and an adequate slope.
3. Maintain the slope of the loading ramps within 15 degrees of the ground.
4. Position the machine so that the machine can drive straight up the loading ramps. The final drives should be toward the rear of the machine. Do not operate the control levers while the machine is on the loading ramps.
5. When you drive over the loading ramp joint areas, maintain the balance point of the machine.
6. To prevent rolling of the machine or sudden movement of the machine, perform the following items:
 - Chock both tracks.
 - Install sufficient tie-downs at several locations.
 - Fasten wire cables.
7. If equipped, remove door hooks, cab bumpers, and fuel tank step as necessary. Refer to local regulations.
 - a. Remove cover (1) and nuts (2) to remove door hook (3).

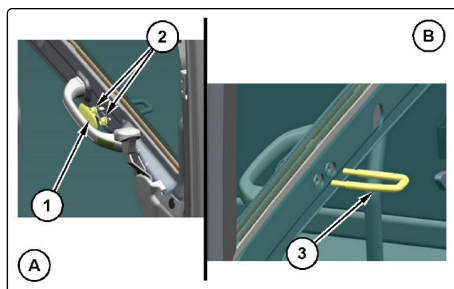

- b. Remove any bumpers on your cab.

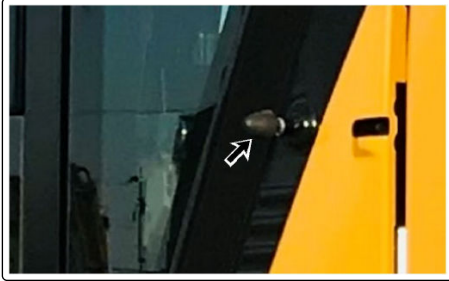

11.7. SECURING THE MACHINE*

SMCS Code: 7000



WARNING

Do not transport the machine if there is a malfunction of the swing parking brake system. The machine may swing during transportation if the swing parking brake system is not functioning properly which could result in injury or death. Contact the CZM After Sales Department support for service.

Comply with any laws that govern the characteristics of a load (length, width, height, and weight).

1. Move the hydraulic lockout control to the LOCKED position.
2. Turn the engine start ring to the OFF position or press the button to stop the engine.
3. Turn the battery disconnect switch to OFF and remove the disconnect switch key.
4. Remove the ether starting aid cylinder, if equipped. See [Replacing the Ether Starting Aid Cylinder* \(page 484\)](#) for the removal procedure.
5. Lock the door and the access covers. Attach any vandalism protection.
6. Cover the exhaust opening.



IMPORTANT

Do not allow the turbocharger to rotate while the engine is not operating. Damage to the turbocharger can result.



IMPORTANT

Before you unload the drilling rig from the means of transport, remove the protective covering from the exhaust opening.

7. Chock the tracks and secure the machine with tie-downs. Make sure that you use the proper rated wire cable. Use the front towing eyes on the lower frame, the rear towing eyes on the lower frame, and the rear towing eye that is on the upper frame. Securely fasten all loose parts and all removed parts to the trailer or to the rail car.
8. When the engine is stopped, the swing parking brake is automatically applied. The swing brake prevents the upper structure from rotating.



IMPORTANT

In freezing weather, protect the cooling system with antifreeze, to the lowest outside expected temperature on the travel route. Or, drain the cooling system completely.

11.8. TYING DOWN THE MACHINE*



Tie Down Point – To tie down the machine, attach the tie-downs to the tie-down points.

For specific weight information see:

- [Transport Dimensions \(page 133\)](#).
- [Transport Dimensions \(page 137\)](#).

1. Use proper rated cables and shackles for tying down the machine.
2. Use the rear eyes and the front eyes that are provided on the lower frame to fasten tie-downs. Use corner protectors for sharp corners.
3. Move the hydraulic lockout control to the LOCKED position.
4. If there is a requirement for diagonal lashing for tying down, use the proper tie-down point on the lower frame. Set the lashing angle which is on the longitudinal axis of the machine and the cable, at 30 to 50 degrees.
5. Keep the transport vehicle surface clean (for example, the trailer deck).
6. For steel deck transport vehicles use skid-inhibiting or anti-slip mats (for example, rubber mats) with a friction coefficient of at least 0.3.

Two methods can be used to tie down a machine. Local and/or regional regulations will determine which method to use.



IMPORTANT

Obey all local and regional governmental regulations.

11.8.1. Frictional and Direct Lashing*

When allowed, a combination of frictional lashing and direct lashing is the preferred method to tie down a machine.

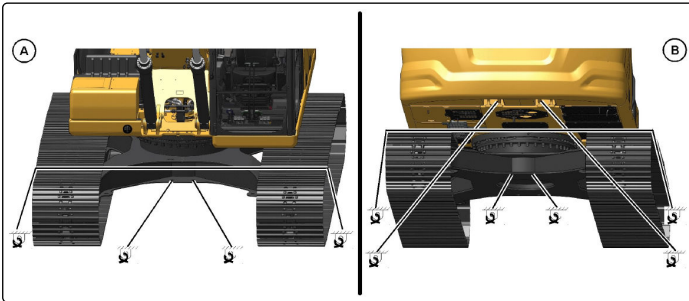

g06184145 Transport-Frictional and Direct Lashing

Pos.	Description
A	Front of the machine
B	Rear of the machine

11.8.2. Diagonal Lashing*

In areas where frictional lashing is not allowed, diagonal lashing can be used as shown below.

Figure 223.

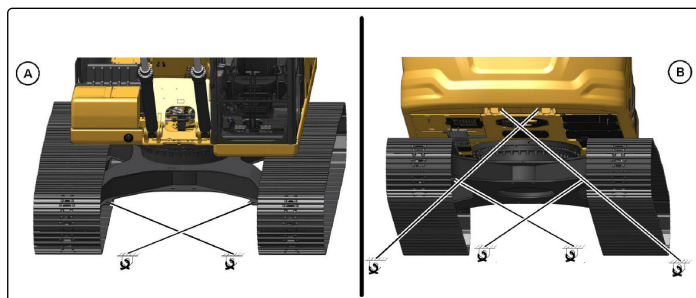

g06184360 Transport-Diagonal Lashing

Table 61. Diagonal Lashing

Pos.	Description
A	Front of the machine
B	Rear of the machine

11.9. LIFTING THE MACHINE*



WARNING

Only use properly rated cables and slings attached to the lift points provided on the machine. Failure to properly secure the machine may result in sudden shifting of the load resulting in death, serious injury, or property damage.

Figure 224.



g06184026 Lifting Points



Lifting Point – To lift the machine, attach the lifting devices to the lifting points.



WARNING

- Do not use footsteps as lifting points.
- Make sure the lifting device/equipment and straps are suitable for handling this weight. For machine transport weights, refer to *Transportation (page 123)*.

- Make sure the machine mast is in the transport position and is secured.
- Check the machine's center of gravity position, refer to *Center of Gravity (page 376)*.
- Use proper rated cables and slings for lifting. The crane should be positioned so that the machine is lifted parallel to the ground.
- To prevent contact with the machine, lifting cables should have a spreader bar of sufficient length.
- Make sure the hydraulic lockout control is in the LOCKED position.
- If the base machine has a full-length roller guard, remove the guard.
- Pass the lifting cable between the first and second bottom rollers, under the machine, and out the first and second rollers on the opposite track. Apply the proper protector to prevent machine/wire damage and slippage. Make sure that the rollers are not affected by the lifting cable. Repeat for the second lifting cable on the other end of the track.

11.10. CENTER OF GRAVITY

Values are valid within the following conditions:

- Machine in transport configuration as described in *Machine Setup For Transportation* (page 360).
- Kelly bar: 4 elements, 120 ft (36.576 mm) / 10,031 lb (4.550 kg).



WARNING

In the case of different configurations, these values are no longer valid, and they must be recalculated. Contact CZM After Sales Department for details.

Failure to follow this warning could result in death or serious injury.

Figure 225.

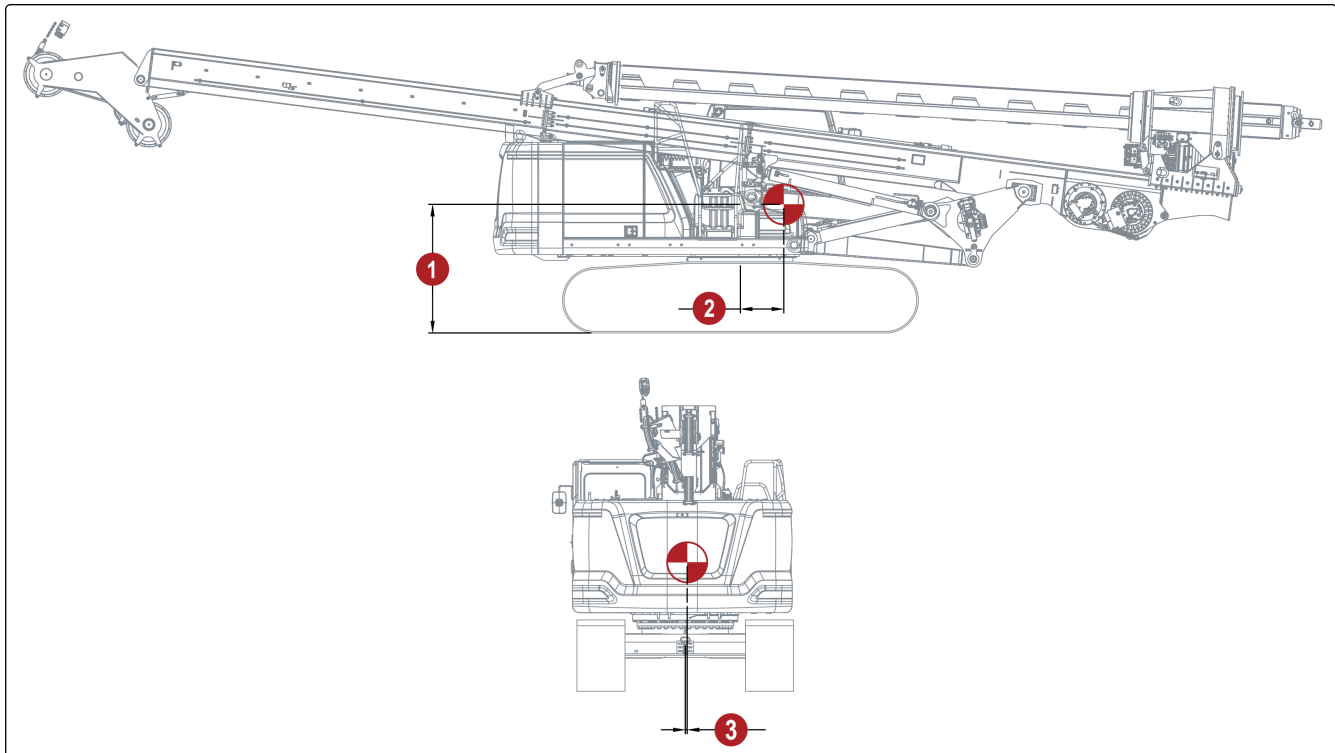

0000483 Center of Gravity-Transportation-Standard Mast

Table 62. Center of Gravity-Transportation

Pos.	Description
1	5.27 ft (1.608,5 mm)
2	1.78 ft (542,9 mm)
3	0.94 in (24 mm)

12. MAINTENANCE

12.1. MAINTENANCE RECOMMENDATIONS

Before making any type of adjustments or servicing, enable all the safety devices provided and consider whether it is necessary to inform the staff involved in the procedure or is operating in the vicinity of the drilling rig.

In particular, provide suitable signs around the area affected and prevent access to any devices whose operation might give rise to unpredictable hazardous conditions, posing a severe risk to personal health and safety.

Carefully read and understand what is written in *Maintenance (page 114)*.



WARNING

Unless specified otherwise, all servicing activities must be carried out with:

- The engine OFF.
- The battery disconnect switch OFF.
- All the machine's moving parts in the most suitable position to facilitate the action that has to be taken and to avoid any additional risks.

The person authorized to service the machine must keep in mind all the actions needed to guarantee the safety of all parties involved and operate in compliance with current rules and regulations concerning occupational safety. Replace excessively worn parts only with original equipment spares.



WARNING

- The operator can override safety limit switches if required for the assembly or disassembly of machine components.
- When safety limit switches are overridden, some operations may cause overturning or damage to the machine.
- Extra care and observation must be taken for operations without functioning limit switches.
- Any limit switch override must be removed once the maintenance task is completed.



DANGER

It is forbidden to step, stand, or walk on the upper part of the base machine.

Failure to follow this warning will cause serious injury or death.



WARNING

Use the oils and greases recommended by the manufacturer.

This will ensure the smooth operation of the machine and the necessary safety level.

Failure to use recommended oils and greases can cause improper operation and damage to the machine.



NOTICE

An aerial work platform (or similar) is needed for some operations.



ENVIRONMENTAL NOTICE

- Make sure that fluids are contained while performing inspection, maintenance, testing, adjusting, and repairs on the machine.
- Be prepared to collect any fluids with suitable containers before opening any lines or components containing fluids.
- Dispose of all fluids according to local regulations and mandates.
- Contact the CZM After Sales Department for tools and supplies suitable to collect and contain fluids on CZM products.

Improper waste disposal can harm the environment.

12.1.1. Welding on Machines and Engines with Electronic Controls*

SMCS Code: 1000; 7000



IMPORTANT

Do not weld on any protective structure. If it is necessary to repair a protective structure, contact CZM After Sales Department.

Proper welding procedures are necessary to avoid damage to the electronic controls and the bearings. When possible, remove the component that must be welded from the machine or the engine and then weld the component. If you must weld near an electronic control on the machine or the engine, temporarily remove the electronic control to prevent heat-related damage. The following steps should be followed to weld on a machine or an engine with electronic controls.

1. Turn off the engine.
2. Turn the engine's start switch to the OFF position.



IMPORTANT

Do NOT use electrical components (ECM or sensors) or electronic component grounding points for grounding the welder.

3. Turn the battery disconnect switch in the OFF position. Refer to *Battery Disconnect Switch** (page 186).
4. Clamp the ground cable from the welder to the component that will be welded. Place the clamp as close as possible to the weld. Make sure that the electrical path from the ground cable to the component does not go through any bearing. Use this procedure to reduce the possibility of damage to the following components:
 - Bearings of the drive train.
 - Hydraulic components.
 - Electrical components.
 - Other components of the machine.
5. Protect any wiring harnesses and components from the debris and the spatter which is created by welding.
6. Use standard welding procedures to weld the materials together.

12.1.2. Severe Service Application*

SMCS Code: 1000

An engine that operates outside of normal conditions is operating in a severe service application.

An engine that operates in a severe service application may need more frequent maintenance intervals in order to maximize the following conditions:

- Reliability.
- Service life.

The number of individual applications causes the impossibility of identifying all of the factors that may contribute to severe service operation. Consult CZM for the unique maintenance that may be necessary for your engine.

An application is a severe service application if any of the following conditions apply.

12.1.2.1. Severe Environmental Factors*

- Frequent operation in dirty air.
- Frequent operation at an altitude which is above 1525 m (5000 ft).
- Frequent operation in ambient temperatures which are above 32° C (90° F).
- Frequent operation in ambient temperatures which are below 0° C (32° F).

12.1.2.2. Severe Operating Conditions*

- Frequent operation with inlet air which has a corrosive content.

- Operation with inlet air which has a combustible content.
- Operation which is outside of the intended application.
- Operation with a plugged fuel filter.
- Extended operation at low idle (more than 20% of hours).
- Frequent cold starts at temperatures below 0° C (32° F).
- Frequent dry starts (starting after more than 72 hours of shutdown).
- Frequent hot shutdowns (shutting down the engine without a minimum of 2 minutes to 5 minutes of cool-down time).
- Operation above the engine-rated speed.
- Operation below the peak torque speed.
- Operating with fuel that does not meet the standards for distillate diesel fuel as stated in *Fluids and Lubricants (page 400)*.
- Operating with a blend of distillate fuel which contains more than 20 percent biodiesel.

12.1.2.3. Improper Maintenance Procedures (Maintenance Procedures Which May Contribute to a Severe Service Application)*

- Inadequate maintenance of fuel storage tanks from causes such as excessive water, sediment, and microorganism growth.
- Extending maintenance intervals beyond the recommended intervals.
- Using fluids that are not recommended in *Fluids and Lubricants (page 400)*.
- Extending maintenance intervals for changing the engine oil and engine coolant.
- Extending maintenance intervals for changing air filters, oil filters, and fuel filters.
- Failure to use a water separator.
- Using filters that are not recommended by CZM.
- Storing the engine for more than 3 months but less than 1 year.

12.2. ACCESS DOOR AND HOOD LOCATIONS*

SMCS Code: 726A-CH

12.2.1. Engine Hood*

Allows access to engine and coolant tank.

1. Open the engine hood.

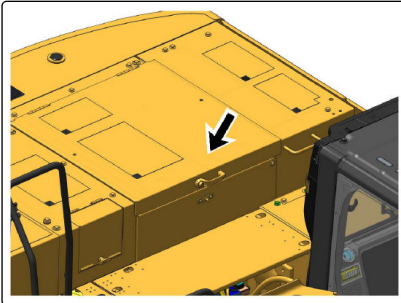

2. Gas spring (1) will lock in place to hold the engine hood open.

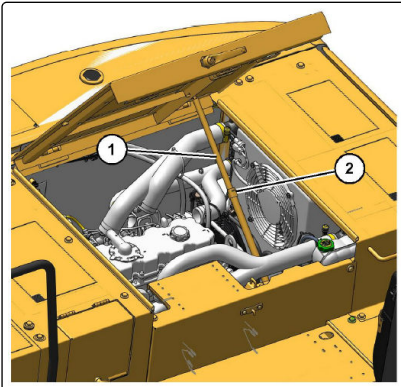

WARNING

When closing the engine hood, only operate the push-button release by hand. Failure to remove hands from the push-button release before closing the engine hood could result in personal injury. Be sure to remove your hands from the push-button release before completely closing the engine hood.



IMPORTANT

Do not add pressure to the engine hood when open.



WARNING

When closing the engine hood, Do Not operate the push-button release by foot. Operation of the push-button release by foot could result in damage to the gas spring of the closing mechanism and/or personal injury. Only operate the push-button release for closing the engine hood by hand.

3. To close the engine hood, support the engine hood with the door handle. Press the push-button release (2) to unlock the gas spring. Release the push button and slowly close the engine hood.

12.2.2. Engine Service Door*

Allows access to the engine oil filler cap and the upper dipstick.

Figure 226.

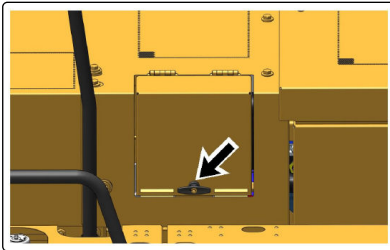

g06183460 g06279315 Engine Service Door

12.2.3. Left Rear Access Door*

Allows access to the coolant sample port, coolant drain, cooling cores, power fuses, battery disconnect switch, and coolant reservoir.

Figure 227.

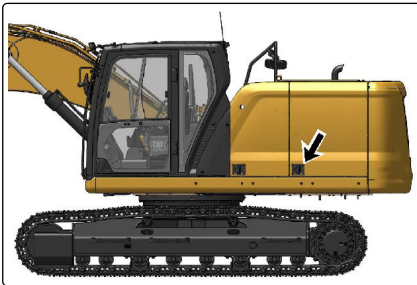

g06179792 Left Rear Door

12.2.4. Left Front Access Door*

Allows access to engine air filter, batteries, and window washer reservoir.

Figure 228.



g06181546 Left Front Door

12.2.5. Right Side Access Door*

Allows access to the engine oil filter, engine oil sampling port, and ground level dipstick. Additionally, the compartment houses the hydraulic pump, fuel filters, refueling pump, fuel tank drain valve, and hydraulic tank sight gauge.

Figure 229.

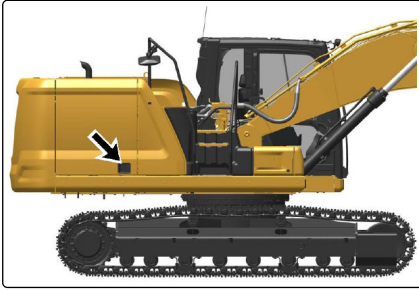

g06182545 Right Access Door

12.2.6. Right Front Access Door*

Allows access to the Diesel Exhaust Fluid (DEF) tank.

Figure 230.

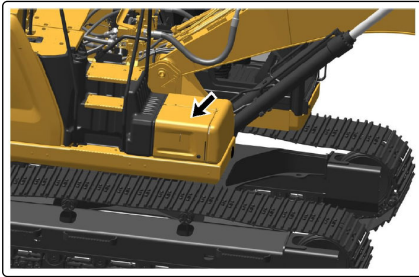

g06183098 DEF Compartment

12.3. PREPARE THE MACHINE FOR MAINTENANCE*

SMCS Code: 1000; 7000



WARNING

Use a suitable lifting device for handling heavy objects (more than 25 kg). If you use a crane, it must be operated by a qualified operator.



WARNING

Personal injury can result from hydraulic oil pressure and hot oil.

- Hydraulic oil pressure can remain in the hydraulic system after the engine has been stopped. Serious injury can be caused if this pressure is not released before any service is done on the hydraulic system.
- Make sure all of the attachments have been lowered, and the oil is cool before removing any components or lines.
- Remove the oil filler cap only when the engine is stopped, and the filler cap is cool enough to touch with your bare hand.



WARNING

- Personal injury can result from improper handling of chemicals.
- Make sure you use all the necessary protective equipment required to do the job.
- Make sure that you read and understand all directions and hazards described on the labels and material safety data sheet of any chemical that is used.
- Observe all safety precautions recommended by the chemical manufacturer for handling, storage, and disposal of chemicals.



ENVIRONMENTAL NOTICE

- Make sure that fluids are contained while performing inspection, maintenance, testing, adjusting, and repairs on the machine.
- Be prepared to collect any fluids with suitable containers before opening any lines or components containing fluids.
- Dispose of all fluids according to local regulations and mandates.
- Contact the CZM After Sales Department for tools and supplies suitable to collect and contain fluids on CZM products.

Improper waste disposal can harm the environment.



IMPORTANT

Permit only one operator on the machine. Keep all other personnel away from the machine or in view of the operator.



NOTICE

- Any maintenance intervention must be done **PREFERENTIALLY** on a clear skies day.
- The machine must be on accessible, solid, horizontal dry ground, without dirt on the tracks if possible.
- The machine must be clean enough to allow a perfect job.
- Clean oil-filling plugs and caps prior to removing them.
- Extra care should be taken not to contaminate new oil.
- The tooling must be removed if the rotary is lowered for inspection.

Carefully read and understand what is written in *Maintenance (page 114)*.

1. Park the machine on a dry, level, solid surface that is free of any debris.

**IMPORTANT**

The surface must be solid enough to support the weight of the machine and any tooling that is used to support the machine.

2. Place blocks in front and behind the tracks.
3. Lower all work tools to the ground.
4. Stop the engine.
5. Release the pressure in the hydraulic system. Refer to [Section: "Releasing of Hydraulic Pressure from the Main Hydraulic System*" \(page 450\)](#) for more information.
6. If the procedure allows it, turn the battery disconnect switch in the OFF position. Refer to [Battery Disconnect Switch* \(page 186\)](#).
7. Perform a visual inspection first:
 - If the visual checks are completed but the problem has not been identified, perform operational checks.
 - If the problem has not been identified, perform instrument tests. This procedure will help to identify system problems.

12.4. MAINTENANCE PLAN

The Drilling Rig must be serviced according to the Maintenance Interval Schedule.

Any abnormal noise or behavior during work must be investigated to prevent failure or accidents due to equipment malfunction.

The base machine must be serviced according to the manufacturer's recommendations. See [Section: "Base Machine Maintenance" \(page 414\)](#).

12.4.1. When Required

12.4.1.1. Machine Base

	Description	Action
<input type="checkbox"/>	Air conditioner/cab heater filter (recirculation)	Inspect/replace. See <i>Inspecting/Replacing the Air Recirculation Filter Element*</i> (page 477).
<input type="checkbox"/>	Battery electrolyte level	Check. See <i>Checking the Battery Electrolyte Level*</i> (page 468).
<input type="checkbox"/>	Battery or battery cable	Inspect/replace. See <i>Inspecting/Replacing the Battery or Battery Cable</i> (page 468).
<input type="checkbox"/>	Cab air filter (fresh air)	Clean/replace. See <i>Cleaning/Replacing the Cab Air Filter*</i> (page 479).
<input type="checkbox"/>	Camera	Clean. See <i>Cleaning the Camera*</i> (page 469).
<input type="checkbox"/>	Condenser (refrigerant)	Clean. See <i>Cleaning the Condenser*</i> (page 478).
<input type="checkbox"/>	Decals	Clean. See <i>Cleaning the Decals</i> (page 485).
<input type="checkbox"/>	DEF filler screen	Clean. See <i>Cleaning the DEF Filler Screen*</i> (page 443).
<input type="checkbox"/>	Diesel exhaust fluid	Drain. See <i>Draining the DEF*</i> (page 444).
<input type="checkbox"/>	Diesel exhaust fluid	Fill. See <i>Filling the DEF*</i> (page 445).
<input type="checkbox"/>	Engine air filter primary and/or secondary element	Replace. See <i>Replacing the Primary Air Filter Element*</i> (page 421), <i>Replacing the Secondary Air Filter Element*</i> (page 422).
<input type="checkbox"/>	Ether starting aid cylinder (If Equipped)	Replace. See <i>Replacing the Ether Starting Aid Cylinder*</i> (page 484).
<input type="checkbox"/>	Fuel system	Prime. See <i>Priming the Fuel System*</i> (page 434).
<input type="checkbox"/>	Fuel cap filter	Replace. See <i>Replacing the Fuel Tank Cap Filter*</i> (page 433).
<input type="checkbox"/>	Fuel tank strainer	Clean. See <i>Cleaning the Fuel Tank Strainer*</i> (page 441).
<input type="checkbox"/>	Fuses	Replace. See <i>Replacing the Fuses*</i> (page 471).
<input type="checkbox"/>	High-intensity discharge lamp (HID)	Replace. See <i>Replacing the High Intensity Discharge Lamp (HID) (If Equipped)*</i> (page 476).
<input type="checkbox"/>	Oil Filter	Inspect. See <i>Inspecting the Oil Filter for Debris*</i> (page 465).
<input type="checkbox"/>	Radiator, aftercooler and oil cooler cores	Clean. See <i>Cleaning the Radiator, Aftercooler and Oil Cooler Cores*</i> (page 465).

	Description	Action
<input type="checkbox"/>	Rollover protective structure (ROPS)	Inspect. See <i>Inspecting the Rollover Protective Structure (ROPS)* (page 480)</i> .
<input type="checkbox"/>	Track tension	Adjust. See <i>Adjusting the Track Tension* (page 498)</i> .
<input type="checkbox"/>	Undercarriage	Check. See <i>Checking the Undercarriage* (page 496)</i> .
<input type="checkbox"/>	Window washer reservoir	Fill. See <i>Filling the Window Washer Reservoir* (page 483)</i> .
<input type="checkbox"/>	Window wiper	Inspect/replace. See <i>Inspecting/Replacing the Window Wiper* (page 483)</i> .
<input type="checkbox"/>	Windows	Clean. See <i>Cleaning the Windows* (page 482)</i> .
Date:		Machine S/N:
Filled By:		Signature:

12.4.2. Every 10 Hours or Daily

12.4.2.1. Machine Base

	Description	Action
<input type="checkbox"/>	Engine oil level	Check. See Checking the Engine Oil Level* (page 414).
<input type="checkbox"/>	Cooling system coolant level	Check. See Checking the Cooling System Coolant Level* (page 430).
<input type="checkbox"/>	Fuel tank	Drain water/sediment. See Draining the Fuel Tank Water and Sediment* (page 442).
<input type="checkbox"/>	Indicators and gauges	Test. See Testing Indicators and Gauges* (page 464).
<input type="checkbox"/>	Track adjustment	Inspect. See Inspecting the Track Adjustment* (page 502).
<input type="checkbox"/>	Travel alarm	Test. See Testing the Travel Alarm* (page 496).
<input type="checkbox"/>	Missing or damaged parts	Inspect.
<input type="checkbox"/>	Fuel system water separator	Drain. See Draining the Fuel System Water Separator* (page 440).
<input type="checkbox"/>	Hydraulic system oil level	Check. See Checking the Hydraulic System Oil Level* (page 462).
<input type="checkbox"/>	Seat belt	Inspect. See Inspecting the Seat Belt* (page 480).
<input type="checkbox"/>	Bolts	Inspect for loose or damaged.
Date:		Machine S/N:
Filled By:		Signature:

12.4.2.2. Rotary and Rotary Guide

	Description	Action
<input type="checkbox"/>	Rotary	Clean externally.
<input type="checkbox"/>	Wear or damage	Check.
<input type="checkbox"/>	Oil leaks	Check.
<input type="checkbox"/>	Bolts	Inspect for damage and wear.
<input type="checkbox"/>	Oil level	Check. See Checking the Rotary Reducer Oil (page 516).
<input type="checkbox"/>	Rotary (8 points)	Lubricate. See Lubricating The Machine (page 406).
<input type="checkbox"/>	Rotary guide wear pads	Lubricate.
Date:		Machine S/N:

	Description	Action
Filled By:		Signature:

12.4.2.3. Main and Auxiliary Winch

	Description	Action
<input type="checkbox"/>	Wire rope wear or damage	Check. See <i>Inspecting the Wire Rope (page 506)</i> .
<input type="checkbox"/>	Limit switches	Test.
<input type="checkbox"/>	Main winch wire rope	Lubricate. See <i>Lubricating the Wire Rope (page 506)</i> .
Date:		Machine S/N:
Filled By:		Signature:

12.4.2.4. Hydraulic System

	Description	Action
<input type="checkbox"/>	Hydraulic cylinders	Inspect for leaks.
<input type="checkbox"/>	Oil cooler	Check. See <i>Checking the Cooling System Coolant Level* (page 430)</i> .
<input type="checkbox"/>	Oil tank	Check oil level. See <i>Checking the Hydraulic System Oil Level* (page 462)</i> .
Date:		Machine S/N:
Filled By:		Signature:

12.4.3. Every 50 Hours or Weekly

12.4.3.1. Parallelogram and Mast Components

	Description	Action
<input type="checkbox"/>	Mast	Inspect the entire length for cracks.
<input type="checkbox"/>	Pins, bolts and nuts	Check for tightness.
<input type="checkbox"/>	Wire rope	Check the fit on mast head pulleys.
<input type="checkbox"/>	Mast guides	Lubricate the full length.
<input type="checkbox"/>	Parallelogram pins	Lubricate (16 points). See Lubricating The Machine (page 406) .
<input type="checkbox"/>	Mast head joint pin	Lubricate. See Lubricating The Machine (page 406) .
<input type="checkbox"/>	Superior mast joint pin	Lubricate. See Lubricating The Machine (page 406) .
<input type="checkbox"/>	Mast head pulley pins	Lubricate (3 points). See Lubricating The Machine (page 406) .
<input type="checkbox"/>	Folding mast link pin	Lubricate (2 points). See Lubricating The Machine (page 406) .
<input type="checkbox"/>	Parallelogram	Inspect for cracks.
Date:		Machine S/N:
Filled By:		Signature:

12.4.3.2. Rotary and Rotary Guide

	Description	Action
<input type="checkbox"/>	Rotary internal keys	Check.
<input type="checkbox"/>	Rotary reducer oil level	Check. See Checking the Rotary Reducer Oil (page 516) .
<input type="checkbox"/>	Bolts	Check torque and integrity.
<input type="checkbox"/>	Wear pads	Adjust set screws. See Adjusting the Rotary Sled Wear Pads (page 521) .
Date:		Machine S/N:
Filled By:		Signature:

12.4.3.3. Main and Auxiliary Winch

	Description	Action
<input type="checkbox"/>	Gearbox and brake oil levels of the main winch	Check. See Checking the Main Winch Reducer/Brake Oil Level (page 508) .

	Description	Action
<input type="checkbox"/>	Gearbox and brake oil levels of the aux. winch	Check. See Checking the Auxiliary Winch Reducer/Brake Oil Level (page 512) .
<input type="checkbox"/>	Cable land	Check wear and integrity.
<input type="checkbox"/>	Bolts	Check torque and integrity.
<input type="checkbox"/>	Cable thimble/hook	Inspect.
Date:		Machine S/N:
Filled By:		Signature:

12.4.3.4. Kelly Bar and A-frame

	Description	Action
<input type="checkbox"/>	Set screws	Check torque and integrity.
<input type="checkbox"/>	Shock absorber	Check.
<input type="checkbox"/>	A-frame wear pads	Check.
<input type="checkbox"/>	A-frame bearings	Lubricate (3 points). See Lubricating The Machine (page 406) .
<input type="checkbox"/>	Joint pin	Lubricate (2 points). See Lubricating The Machine (page 406) .
<input type="checkbox"/>	Cable swivel	Lubricate and inspect. See Lubricating The Machine (page 406) .
Date:		Machine S/N:
Filled By:		Signature:

12.4.3.5. Hydraulic System

	Description	Action
<input type="checkbox"/>	Hoses	Inspect for damage and wear.
Date:		Machine S/N:
Filled By:		Signature:

12.4.4. Every 250 Hours or Monthly

12.4.4.1. Machine Base

	Description	Action
<input type="checkbox"/>	Engine oil filter (first change only)	Replace. See Changing the Engine Oil and Filter* (page 416) .
<input type="checkbox"/>	Engine oil (first change only)	Drain and refill. See Changing the Engine Oil and Filter* (page 416) .
<input type="checkbox"/>	Cooling system coolant sample (level 1)	Obtain. See Obtaining the Cooling System Coolant Sample (Level 1)* (page 430) .
<input type="checkbox"/>	Engine oil sample	Obtain. See Obtaining the Engine Oil Sample* (page 416) .
<input type="checkbox"/>	Final drive oil sample	Obtain. See Obtaining the Final Drive Oil Sample* (page 505) .
Date:		Machine S/N:
Filled By:		Signature:

12.4.4.2. Parallelogram and Mast Components

	Description	Action
<input type="checkbox"/>	Mast head pulleys	Inspect for damage and wear.
Date:		Machine S/N:
Filled By:		Signature:

12.4.4.3. Rotary and Rotary Guide

	Description	Action
<input type="checkbox"/>	Oil sample for analysis	Obtain.
<input type="checkbox"/>	Rotary oil (first change only)	Drain and refill. See Draining and Refilling the Rotary Reducer Oil (page 517) .
Date:		Machine S/N:
Filled By:		Signature:

12.4.4.4. Main and Auxiliary Winch

	Description	Action
<input type="checkbox"/>	Main winch gearbox oil (first change only)	Drain and refill. See <i>Draining and Refilling the Main Winch Reducer/Brake Oil (page 510)</i> .
<input type="checkbox"/>	Main winch brake oil (first change only)	Drain and refill. See <i>Draining and Refilling the Main Winch Reducer/Brake Oil (page 510)</i> .
Date:		Machine S/N:
Filled By:		Signature:

12.4.5. Every 500 Hours or Quarterly

12.4.5.1. Machine Base

	Description	Action
<input type="checkbox"/>	Initial Cooling system coolant sample (level 2)	Obtain. See <i>Obtaining the Cooling System Coolant Sample (Level 2)*</i> (page 431).
<input type="checkbox"/>	Final drive oil (first change only)	Change. See <i>Changing the Final Drive Oil*</i> (page 502).
<input type="checkbox"/>	Swing drive oil (first change only)	Change. See <i>Changing the Swing Drive Oil*</i> (page 490).
<input type="checkbox"/>	Engine oil and filter	Change. See <i>Changing the Engine Oil and Filter*</i> (page 416).
<input type="checkbox"/>	Final drive oil level	Check. See <i>Checking the Final Drive Oil Level*</i> (page 504).
<input type="checkbox"/>	Fuel lift pump strainer	Replace. See <i>Replacing the Fuel Lift Pump Strainer (In-line Filter)*</i> (page 433).
<input type="checkbox"/>	Hydraulic system oil sample	Obtain. See <i>Obtaining the Hydraulic System Oil Sample*</i> (page 464).
<input type="checkbox"/>	Swing bearing	Lubricate. See <i>Lubricating the Swing Bearing*</i> (page 490).
<input type="checkbox"/>	Swing drive oil level	Check. See <i>Checking the Swing Drive Oil Level*</i> (page 492).
<input type="checkbox"/>	Swing drive oil sample	Obtain. See <i>Obtaining the Swing Drive Oil Sample*</i> (page 492).
Date:		Machine S/N:
Filled By:		Signature:

12.4.5.2. Rotary and Rotary Guide

	Description	Action
<input type="checkbox"/>	Rotary casing oil	Drain and refill. See <i>Draining and Refilling the Rotary Casing Oil</i> (page 520).
<input type="checkbox"/>	Oil sample for analysis	Obtain.
Date:		Machine S/N:
Filled By:		Signature:

12.4.6. Every 1000 Hours or Annually

12.4.6.1. Machine Base

	Description	Action
<input type="checkbox"/>	Battery	Clean. See Cleaning the Battery* (page 467).
<input type="checkbox"/>	Battery hold-down	Tighten. See Tightening the Battery Hold-Down* (page 469).
<input type="checkbox"/>	Diesel exhaust fluid filter	Replace. See Replacing the DEF Filter (page 446).
<input type="checkbox"/>	Fuel system primary filter (water separator) element	Replace. See Replacing the Fuel System Primary Filter (Water Separator) Element* (page 435).
<input type="checkbox"/>	Fuel system secondary filter	Replace. See Replacing the Fuel System Secondary Filter* (page 438).
<input type="checkbox"/>	Swing drive oil	Change. See Changing the Swing Drive Oil* (page 490).
<input type="checkbox"/>	Engine belt	Inspect/Adjust/Replace. See Inspecting/Adjusting/Replacing the Belt (page 432).
Date:		Machine S/N:
Filled By:		Signature:

12.4.6.2. Rotary and Rotary Guide

	Description	Action
<input type="checkbox"/>	General inspection to be done by a technician	Inspection.
<input type="checkbox"/>	Seals	Check integrity.
<input type="checkbox"/>	Rotary reducer oil	Change. See Checking the Rotary Reducer Oil (page 516).
<input type="checkbox"/>	Rotary casing oil	Change. See Draining and Refilling the Rotary Casing Oil (page 520).
<input type="checkbox"/>	Rotary keys	Replace.
<input type="checkbox"/>	Rotary wear pads	Replace. See Rotary Sled Wear Pads (page 521).
Date:		Machine S/N:
Filled By:		Signature:

12.4.6.3. Main and Auxiliary Winch

	Description	Action
<input type="checkbox"/>	Main winch and brake oil	Drain and refill. See Draining and Refilling the Main Winch Reducer/Brake Oil (page 510).

	Description	Action
<input type="checkbox"/>	Main winch cable	Inspect. See Inspecting the Wire Rope (page 506) .
<input type="checkbox"/>	Auxiliary winch and brake oil	Drain and refill. See Draining and Refilling the Auxiliary Winch Reducer/Brake Oil (page 514) .
<input type="checkbox"/>	Auxiliary winch cable	Inspect. See Inspecting the Wire Rope (page 506) .
Date:		Machine S/N:
Filled By:		Signature:

12.4.6.4. Hydraulic System

	Description	Action
<input type="checkbox"/>	Hydraulic system oil sample	Obtain. See Obtaining the Hydraulic System Oil Sample* (page 464) .
<input type="checkbox"/>	Hydraulic lines and connections	Inspect for damage and wear. Procedure to be performed by a technician.
Date:		Machine S/N:
Filled By:		Signature:

12.4.6.5. Kelly Bar

	Description	Action
<input type="checkbox"/>	Kelly bar	Disassemble the telescopic rod and inspect all elements for excessive wear and damage.
<input type="checkbox"/>	A-frame wear pads	Replace. See Replacing the A-frame Wear Pads (page 524) .
Date:		Machine S/N:
Filled By:		Signature:

12.4.7. Every 2000 Hours

12.4.7.1. Machine Base

	Description	Action
<input type="checkbox"/>	Track, Final drive oil	Change. See Changing the Final Drive Oil* (page 502).
<input type="checkbox"/>	Fumes disposal filter element	Replace. See Replacing the Fumes Disposal Filter Element* (page 425).
<input type="checkbox"/>	Hydraulic system oil filter (return)	Replace. See Replacing the Hydraulic System Oil Filter (Return)* (page 459).
<input type="checkbox"/>	Hydraulic system oil	Drain and refill. See Hydraulic System* (page 450).
<input type="checkbox"/>	Receiver dryer (refrigerant)	Replace. See Replacing the Receiver Dryer (Refrigerant)* (page 466).
<input type="checkbox"/>	Swing gear	Lubricate. See Lubricating the Swing Gear* (page 493).
Date:		Machine S/N:
Filled By:		Signature:

12.4.8. Every Year

12.4.8.1. Machine Base

	Description	Action
<input type="checkbox"/>	Cooling system coolant sample (level 2)	Obtain. See Obtaining the Cooling System Coolant Sample (Level 2)* (page 431).
Date:		Machine S/N:
Filled By:		Signature:

12.4.9. Every 5000 Hours

12.4.9.1. Machine Base

	Description	Action
<input type="checkbox"/>	Diesel exhaust fluid injector	Replace. See Replacing the DEF Injector* (page 449).
Date:		Machine S/N:
Filled By:		Signature:

12.4.10. Every 6000 Hours or 3 Years

12.4.10.1. Machine Base

	Description	Action
<input type="checkbox"/>	Seat belt	Replace. See <i>Replacing the Seat Belt*</i> (page 481).
<input type="checkbox"/>	Cooling system coolant extender (ELC)	Add. See <i>Adding the Cooling System Coolant Extender (ELC)*</i> (page 429).
Date:		Machine S/N:
Filled By:		Signature:

12.4.11. Every 12000 Hours or 6 Years

12.4.11.1. Machine Base

	Description	Action
<input type="checkbox"/>	Cooling system	Drain and refill. See <i>Changing the Cooling System Coolant (ELC)*</i> (page 427).
Date:		Machine S/N:
Filled By:		Signature:

12.5. FLUIDS AND LUBRICANTS

12.5.1. Recommended Fluids and Lubricants

12.5.1.1. Diesel Fuel Recommendations

Figure 231.

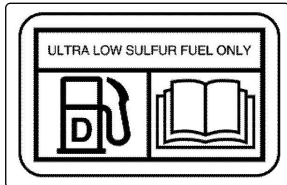

g03218956 Engine-Ultra Low Sulfur Fuel Only Film

Diesel fuel must meet the latest revisions of “ASTM D975” and “EN 590” to ensure optimum engine performance.



IMPORTANT

Ultra Low Sulfur Diesel (ULSD) fuel 0.0015 percent (≤ 15 ppm (mg/kg)) sulfur is required by regulation for use in engines certified to nonroad Tier 4 standards (U.S. EPA Tier 4 certified) and that are equipped with exhaust aftertreatment systems.

Misfuelling with fuels of higher sulfur level can have the following negative effects:

- Shorten the time interval between aftertreatment device service intervals (cause the need for more frequent service intervals).
- Adversely impact the performance and life of aftertreatment devices (cause loss of performance).
- Reduce regeneration intervals of aftertreatment devices.
- Reduce engine efficiency and durability.
- Increase the wear.
- Increase the corrosion.
- Increase the deposits.
- Lower fuel economy.
- Shorten the time period between oil drain intervals (more frequent oil drain intervals).
- Increase overall operating costs.

Failures that result for the use of improper fuels are not CZM factory defects. Therefore, the cost of repairs would not be covered by a CZM warranty.

12.5.1.2. Diesel Exhaust Fluid (DEF) Recommendations

Diesel Exhaust Fluid (DEF) is a liquid that is injected into the exhaust system of engines equipped with Selective Catalytic Reduction (SCR) systems. SCR reduces emissions of nitrogen oxides (NOx) in diesel engine exhaust.

Diesel Exhaust Fluid (DEF) is also known under other names including Aqueous Urea Solution (AUS) 32, AdBlue, or generically referred to as urea.

In engines equipped with SCR emissions reduction system, DEF is injected in controlled amounts into the engine exhaust stream. At the elevated exhaust temperature, urea in DEF is converted to ammonia. The ammonia chemically reacts with NOx in diesel exhaust in the presence of the SCR catalyst. The reaction converts NOx into harmless nitrogen (N₂) and water (H₂O).

DEF must meet all the requirements defined by “ISO 22241-1” Requirements.

In North America, commercial DEF that is API approved and meets all the requirements defined in “ISO 22241-1” may be used in Cat engines that are equipped with SCR systems. The supplier should provide documentation to prove that the DEF is compliant with the requirements of “ISO 22241-1”.

**IMPORTANT**

Do not use agriculture-grade urea solutions. Do not use any fluids that do not meet “ISO 22241-1” Requirements in SCR emissions reduction systems. Use of these fluids can result in numerous problems including damage to SCR equipment and a reduction in NOx conversion efficiency.

DEF is a solution of solid urea that is dissolved in demineralized water to produce a final concentration of 32.5% urea. DEF concentration of 32.5% is optimal for use in SCR systems. DEF solution of 32.5% urea has the lowest attainable freeze point of $-11.5\text{ }^{\circ}\text{C}$ ($11.3\text{ }^{\circ}\text{F}$). DEF concentrations that are higher or lower than 32.5% have higher freeze points. DEF dosing systems and “ISO 22241-1” specifications are designed for a solution that is approximately 32.5%.

DEF solution is typically colorless and clear. Changes to color or clarity are indicators of quality issues. Quality of DEF can degrade when stored and handled inappropriately or if DEF is not protected from contamination.

If quality issues are suspected, testing of DEF should focus on urea percentage, alkalinity as NH_3 and biuret content. DEF that does not pass all these tests or that is no longer clear should not be used.

12.5.1.2.1. Materials compatibility

DEF is corrosive. Due to the corrosion caused, DEF must be stored in tanks constructed of approved materials. Recommended storage materials are the following.

Stainless Steels:

- 304 (S30400)
- 304L (S30403)
- 316 (S31600)
- 316L (S31603)

Alloys and metals:

- Chromium Nickel (CrNi)
- Chromium Nickel Molybdenum (CrNiMo)
- Titanium

Non-metallic materials:

- Polyethylene
- Polypropylene
- Polyisobutylene
- Teflon (PFA)
- Polyfluoroethylene (PFE)
- Polyvinylidene fluoride (PVDF)
- Polytetrafluoroethylene (PTFE)

Materials NOT compatible with DEF solutions include Aluminum, Magnesium, Zinc, Nickel coatings, Silver and Carbon steel, and Solders containing any of the above. Unexpected reactions may occur if DEF solutions come in contact with any non-compatible material or unknown materials.

12.5.1.2.2. Bulk storage

Follow all local regulations covering bulk storage tanks. Follow proper tank construction guidelines. Tank volume typically should be 110% of planned capacity. Appropriately vent indoor tanks. Plan for control of overflow of the tank. Heat tanks that dispense DEF in cold climates.

Bulk tank breathers should be fitted with filtration to keep airborne debris from entering the tank. Desiccant breathers should not be used because water will be absorbed, which potentially can alter DEF concentration.

12.5.1.2.3. Handling

Follow all local regulations covering transport and handling. DEF transport temperature is recommended to be -5 °C (23 °F) to 25 °C (77 °F). All transfer equipment and intermediate containers should be used exclusively for DEF. Containers should not be reused for any other fluids. Ensure that transfer equipment is made from DEF-compatible materials. Recommended material for hoses and other non-metallic transfer equipment includes:

- Nitrile Rubber (NBR)
- Fluoroelastomer (FKM)
- Ethylene Propylene Diene Monomer (EPDM)

The condition of hoses and other nonmetallics that are used with DEF should be monitored for signs of degradation. DEF leaks are easily recognizable by white urea crystals that accumulate at the site of the leak. Solid urea can be corrosive to galvanized or unalloyed steel, aluminum, copper, and brass. Leaks should be repaired immediately to avoid damage to surrounding hardware.

12.5.1.2.4. Cleanliness

Contaminants can degrade the quality and life of DEF. Filtering DEF is recommended when dispensed into the DEF tank. Filters should be compatible with DEF and should be used exclusively with DEF. Check with the filter supplier to confirm compatibility with DEF before using. Mesh-type filters using compatible metals, such as stainless steel, are recommended. Paper (cellulose) media and some synthetic filter media are not recommended because of degradation during use.

Care should be taken when dispensing DEF. Spills should be cleaned immediately. Machine or engine surfaces should be wiped clean and rinsed with water. Caution should be used when dispensing DEF near an engine that has recently been running. Spilling DEF onto hot components will cause harmful vapors.

12.5.1.2.5. Stability

IMPORTANT Storing Diesel Exhaust Fluid in high heat areas is not recommended. Do not store DEF in high heat generating areas on the machine, such as the pump compartment or the engine compartment. The quality of the DEF can degrade when exposed to high temperatures.

DEF fluid is stable when stored and handled properly. The quality of DEF rapidly degrades when stored at high temperatures. The ideal storage temperature for DEF is between -9 °C (15.8 °F) and 25 °C (77 °F). DEF that is stored above 35 °C (95 °F) for longer than 1 month must be tested before use. Testing should evaluate Urea Percentage, Alkalinity as NH3 and Biuret content.

The length of storage of DEF is listed in the following table:

Table 63.

Storage Temperature	Expected DEF Life
Below 25 °C (77 °F)	18 months
25 °C (77 °F) to 30 °C (86 °F)	12 months
30 °C (86 °F) to 35 °C (95 °F)	6 months
Above 35 °C (95 °F)	Test quality before use.

Refer to “ISO 22241” document series for more information about DEF quality control.

Note: Dispose of all fluids according to applicable regulations and mandates.

12.5.2. Regular Ambient Temperature

-4°F to +104°F (-20°C to +40°C)

Lubricant	Manufacturer	Type
Engine Oil	Shell	Shell Rotella T4 Triple Protection 10W-30
	Caterpillar	CAT DEO-ULS SYN-SAE10W-30
	Mobil	Mobil Delvac 1 ESP 5W-40
Pump Coupling (Oil)	Shell	Shell Rotella T4 Triple Protection 10W-30
	Caterpillar	CAT DEO-ULS SYN-SAE10W-30
	Mobil	Mobil Delvac 1 ESP 5W-40
Hydraulic Oil	Shell	Shell Spirax S4 CX 10W
	Caterpillar	CAT HYDO Advanced 10 SAE 10W
	Mobil	Mobiltrans HD 10W
Coolant (Cooling System) (>-37 °C) (>-34.6 °F)	Shell	Shell Rotella ELC Pre-diluted 50/50
	Caterpillar	CAT ELC
	Mobil	Mobil Permazone 50/50 Diluted Antifreeze & Coolant
Swing Drive, Final Drive (Oil)	Shell	Shell Spirax S4 CX 50
	Caterpillar	CAT TDTO SAE 50
	Mobil	Mobiltrans HD 50
Main and Aux. Winches, Rotary Planetary Gear (Oil)	Shell	Shell Omala S4 GX 220
	Caterpillar	N/A
	Mobil	Mobil SHC Gear 220
Main Winch, Service Winch, Brake (Oil)	Shell	Shell Hydraulic S1 M 68
	Caterpillar	N/A
	Mobil	Mobil DTE 26 - ISO 68
Rotary Main Case (Oil)	Shell	Shell Omala S4 GX 460
	Caterpillar	N/A
	Mobil	Mobil SHC Gear 460
Swing Bearing, Swing Gear, Crawler Slides, Swivel/Rotary and A-frame Bearings, Pulley Bearings, Pins and Bushings (Grease)	Shell	Shell Gadus S3 V460D 2
	Caterpillar	CAT Advanced 3 Moly Grease
	Mobil	Mobil Grease XHP 462
Kelly Bar, Mast Railways (Grease)	Shell	Shell Gadus S2 V220AC

Lubricant	Manufacturer	Type
	Caterpillar	CAT Multipurpose Grease
	Mobil	Mobilith SHC 220

12.5.3. Cold Weather

-22°F (Min -30°C)

Lubricant	Manufacturer	Type
Engine Oil	Caterpillar	CAT DEO-ULS Cold Weather SAE 0W-40
Pump Coupling (Oil)	Caterpillar	CAT DEO-ULS Cold Weather SAE 0W-40
Hydraulic Oil	Caterpillar	CAT DEO-ULS Cold Weather SAE 0W-40
Coolant (Cooling System) (>-37 °C) (>-34.6 °F)	Shell	Shell Rotella ELC Pre-diluted 50/50
	Caterpillar	CAT ELC
	Mobil	Mobil Permazone 50/50 Diluted Antifreeze & Coolant
Final Drive, Crowd Planetary, Rotary Main Case, Auxiliary Winch Planetary (Oil)	Shell	Shell Omala S4 GX 68
	Caterpillar	N/A
	Mobil	Mobil SHC 68
Aux. Winch Brake, Chain Reducer Brake (Oil)	Shell	N/A
	Caterpillar	N/A
	Mobil	N/A
Crawler Slides, Pulley Bearings, Pins and Bushings (Grease)	Shell	Shell Gadus S2 V20XKD
	Caterpillar	CAT Arctic Platinum Grease
	Mobil	Mobilgrease XHP 322 Mine
Kelly Bar, Mast Railways (Grease)	Shell	Shell Gadus S2 V20XKD
	Caterpillar	CAT Arctic Platinum Grease
	Mobil	Mobilith SHC 220

12.5.4. Hot Weather

122°F (Max 50°C)

Lubricant	Manufacturer	Type
Engine Oil	Shell	Shell Rotella T4 Triple Protection 15W-40
	Caterpillar	CAT DEO-ULS SAE 15W-40
	Mobil	Mobil Delvac Extreme 15W-40

Lubricant	Manufacturer	Type
Pump Coupling (Oil)	Caterpillar	CAT DEO-ULS SAE 15W-40
Hydraulic Oil	Shell	Shell Spirax S4 CX 30
	Caterpillar	CAT HYDO Advanced 10 SAE 15W-40
Coolant (Cooling System) (>-37 °C) (>-34.6 °F)	Shell	Shell Rotella ELC Pre-diluted 50/50
	Caterpillar	CAT ELC
	Mobil	Mobil Permazone 50/50 Diluted Antifreeze & Coolant
Swing Drive, Final Drive (Oil)	Shell	Shell Spirax S4 CX 50
	Caterpillar	CAT TDTO SAE 50
	Mobil	Mobiltrans HD 50
Main and Aux. Winches, Rotary Planetary Gear (Oil)	Shell	Shell Omala S4 GX 320
	Caterpillar	N/A
	Mobil	Mobil SHC 320
Main Winch, Service Winch, Brake (Oil)	Shell	Shell Hydraulic S1 M 68
	Caterpillar	N/A
	Mobil	Mobil DTE 26 - ISO 68
Rotary Main Case (Oil)	Shell	Shell Omala S4 GX 320
	Caterpillar	N/A
	Mobil	Mobil Gear 632
Swing Bearing, Swing Gear, Crawler Slides, Swivel/Rotary and A-frame Bearings, Pulley Bearings, Pins and Bushings (Grease)	Caterpillar	CAT Desert Gold Grease
Kelly Bar, Mast Railways (Grease)	Shell	Shell Gadus S2 V220AC
	Caterpillar	CAT Desert Gold Grease
	Mobil	Mobilith SHC 220

12.6. LUBRICATING THE MACHINE



The table below specifies the lubrication requirements for EK125.

Following these recommendations will prevent excessive wear and reduce the possibility of failure, increasing productivity.

Always use oils or lubricants with specifications equivalent to those specified below.



CAUTION

- These are recommended intervals for regular use. It is the responsibility of the Operator to evaluate working conditions and adjust intervals as necessary. Intervals are based on work hours.
- Most lubrication points on the machine are mirrored, ensure that both sides are lubricated, where applicable.
- The balloons in the drawings are combined with ISO 7000 symbols which have the following meaning:
 -  means the component is lubricated with oil.
 -  means the component is lubricated with grease.
 -  means the component must be cleaned prior to lubricating.
- Balloons are color-coded according to the intervals in the chart below.
- For more information about lubricant specifications, see [Fluids and Lubricants \(page 400\)](#).



CAUTION

- Avoid prolonged and repeated skin contact with spent lubricants. Such contact can cause severe skin diseases or other serious injuries. Wash thoroughly after contact.
- Do not mix oils of different brands or characteristics.
- Thoroughly clean the caps before installing them.
- Before injecting grease into the nipples, clean them thoroughly to prevent dust or impurities from mixing with the grease, reducing or even canceling the lubrication effect.



NOTICE

An optional automatic lubricating system can be installed.
In this case, the items not indicated as automated in the table below still have to be performed manually.

Table 64. Lubrication Table

Pos.	Description	Check	Change	Grease	Lubricant Rec. & Qty	Fittings Qty	Auto Lu- bric. ^a
01	Main Winch Reducer ^b .	250h	1000h	N/A	Oil, Shell Oma-la S4 GX 220 Approx. 7 L	1	
02	Brake, Main Winch Reducer ^b .	250h	1000h	N/A	Oil, Shell Hy-draulic S1 M 68	1	
03	Brake, Aux. Winch Reducer ^b .	250h	1000h	N/A	Oil, Shell Hy-draulic S1 M 68	1	
04	Auxiliary Winch Reducer ^b .	250h	1000h	N/A	Oil, Shell Oma-la S4 GX 220 Approx. 4,5 L	1	
05	Bearing, Auxiliary Winch	N/A	N/A	50h	Grease, CAT Adv. 3 Moly Grease	1	X
06	Bearing, Main Winch	N/A	N/A	50h	Grease, CAT Adv. 3 Moly Grease	1	X
07,08	Bearing, Main Mast Head Sheave	N/A	N/A	50h	Grease, CAT Adv. 3 Moly Grease	4	X
09	Bearing, Aux Mast Head Sheave	N/A	N/A	50h	Grease, CAT Adv. 3 Moly Grease	1	
10	Pin, Mast Head	N/A	N/A	50h	Grease, CAT Adv. 3 Moly Grease	2	
11	Pin, Kelly Bar Guide	N/A	N/A	50h	Grease, CAT Adv. 3 Moly Grease	2	
12	Pin, Kelly Bar Guide	N/A	N/A	50h	Grease, CAT Adv. 3 Moly Grease	2	
13	Cable Swivel	N/A	N/A	50h	Grease, CAT Adv. 3 Moly Grease	1	
14,15	Tilt Cylinder	N/A	N/A	50h	Grease, CAT Adv. 3 Moly Grease	4	X

Pos.	Description	Check	Change	Grease	Lubricant Rec. & Qty	Fittings Qty	Auto Lu-bric. ^a
16-19	Pins, Parallelogram	N/A	N/A	50h	Grease, CAT Adv. 3 Moly Grease	8	X
20,21	Pins, Triangular Element	N/A	N/A	50h	Grease, CAT Adv. 3 Moly Grease	4	X
22,23	Pins, Parallelogram Cylinder	N/A	N/A	50h	Grease, CAT Adv. 3 Moly Grease	4	X
24	Pin, Mast Tilt	N/A	N/A	50h	Grease, CAT Adv. 3 Moly Grease	1	X
25	Mast Guide	N/A	N/A	8h	Grease, Shell Gadus S2 V220C	2	
26	Crowd Cylinder	N/A	N/A	1000h	Grease, CAT Adv. 3 Moly Grease	1	
27	Bearing, Kelly Bar Guide	N/A	N/A	8h	Grease, CAT Adv. 3 Moly Grease	3	
28	Undercarriage	N/A	N/A	50h	Grease, CAT Adv. 3 Moly Grease	4	
29	Bearing, Swing ^b .	N/A	N/A	500h	Grease, CAT Adv. 3 Moly Grease	2	
30	Gear, Swing ^b .	N/A	N/A	2000h	Grease, CAT Adv. 3 Moly Grease	1	
31	Pin, Rotary Tilt	N/A	N/A	50h	Grease, CAT Adv. 3 Moly Grease	2	
32	Rotary Head Reducer ^b .	250h	1000h	N/A	Oil, Shell Omala S4 GX 220 Approx. 4,5 L	1	
33	Rotary Head Gearing ^b .	50h	1000h	N/A	Oil, Shell Omala S4 GX460 Approx. 19 L	1	

Pos.	Description	Check	Change	Grease	Lubricant Rec. & Qty	Fittings Qty	Auto Lu-bric. ^{a.}
34	Bearing, Rotary Pinion ^{c.}	250h	N/A	1000h	See footnote ^{c.}	1	
35,36	Bearings, Rotary Head	N/A	N/A	8h	Grease, CAT Adv. 3 Moly Grease	4	X
37	Cable, Main Winch ^{b.}	8h	N/A	When necessary. See <i>Wire Ropes Maintenance (page 506)</i> .	1		
38	Cable, Aux. Winch ^{b.}	8h	N/A	When necessary. See <i>Wire Ropes Maintenance (page 506)</i> .	1		

^{a.}Applicable only for machines equipped with the Automatic Lubrication System.

^{b.}Refer to specific procedures for instructions and additional information.

^{c.}The Rotary Pinion Bearing is lubricated through the indicated plug, following the procedure:

1. Pour Shell Omala S4 GX 460 oil into the pinion chamber until the oil covers/soaks the bearing all the way.
2. Once the bearing is submerged, add Shell Gadus S3 V460D 2 (high-temperature grease) [or equivalent lubricant] half-way up the pinion shaft.

Figure 232.

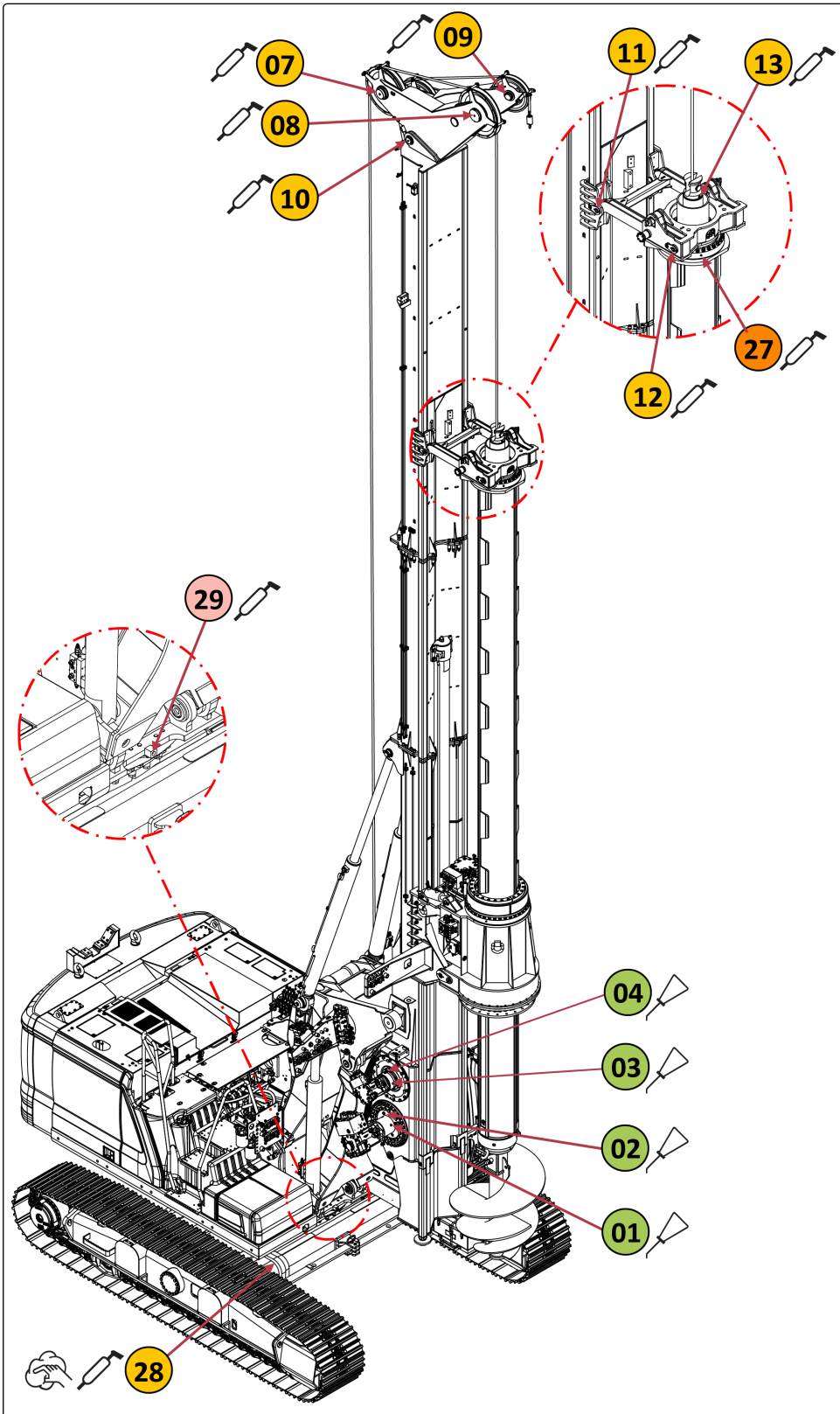

000515 Lubrication Points 1

Figure 233.

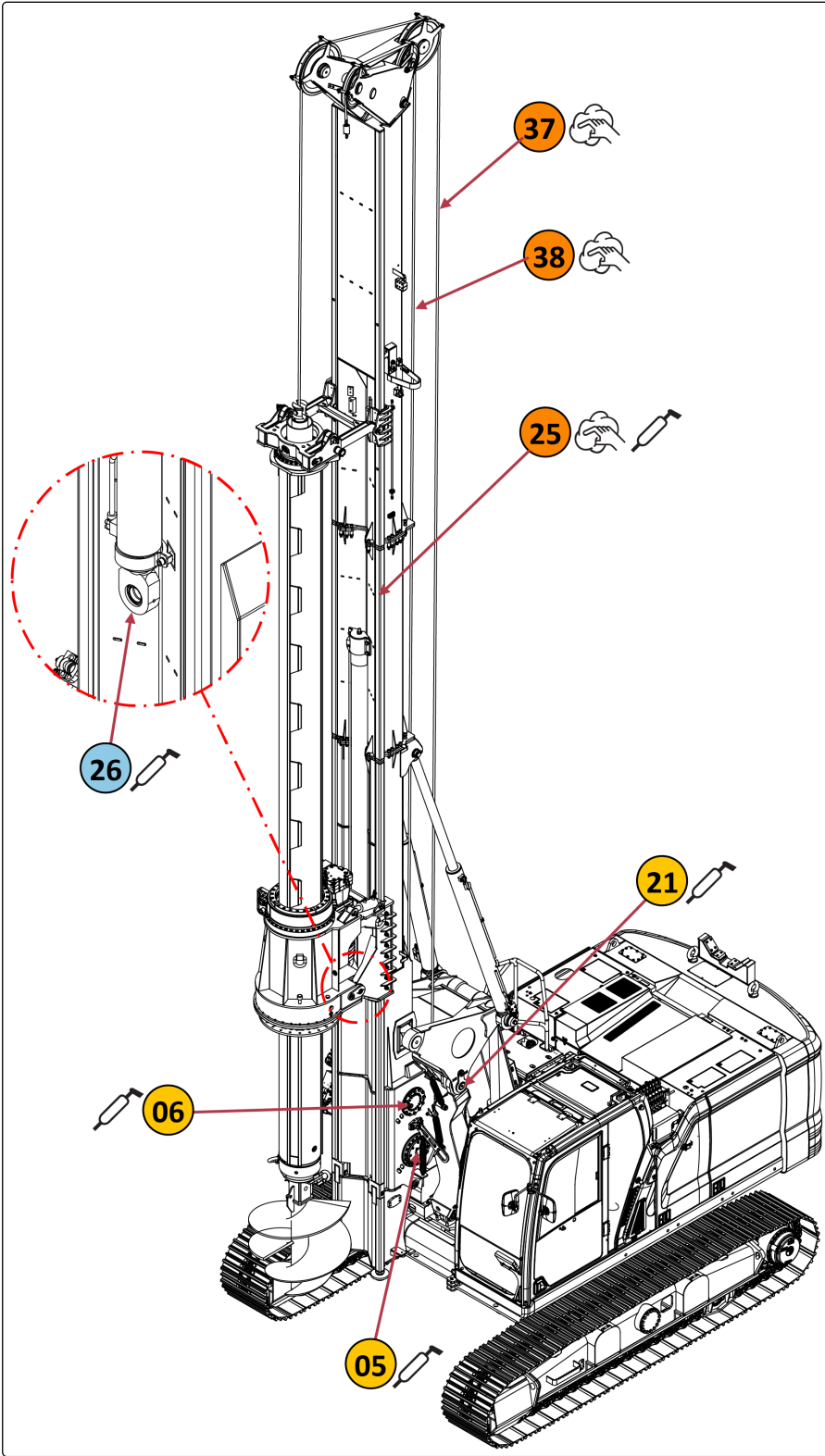

0000515 Lubrication Points 2

Figure 234.

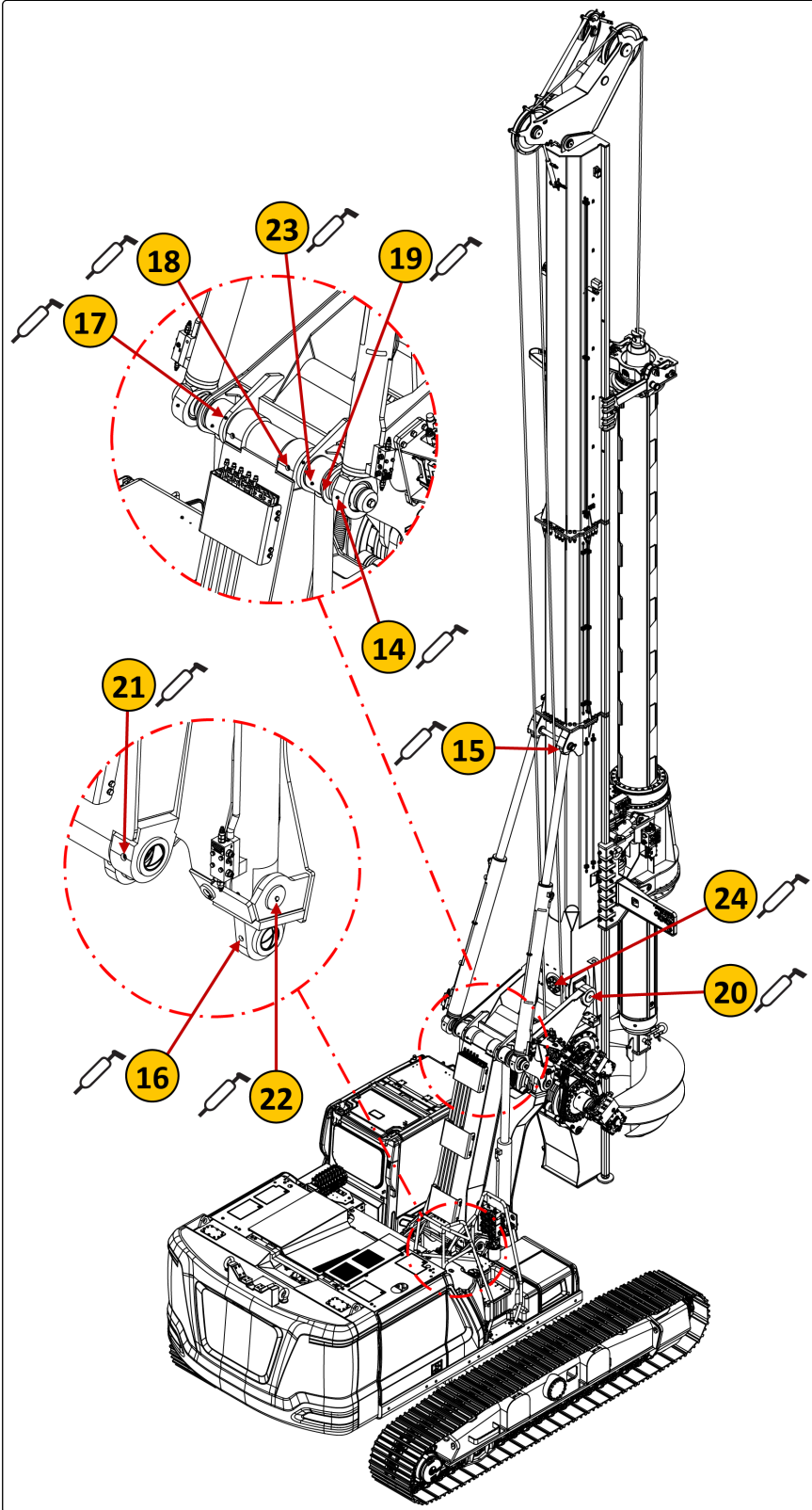

0000515 Lubrication Points 3

Figure 235.

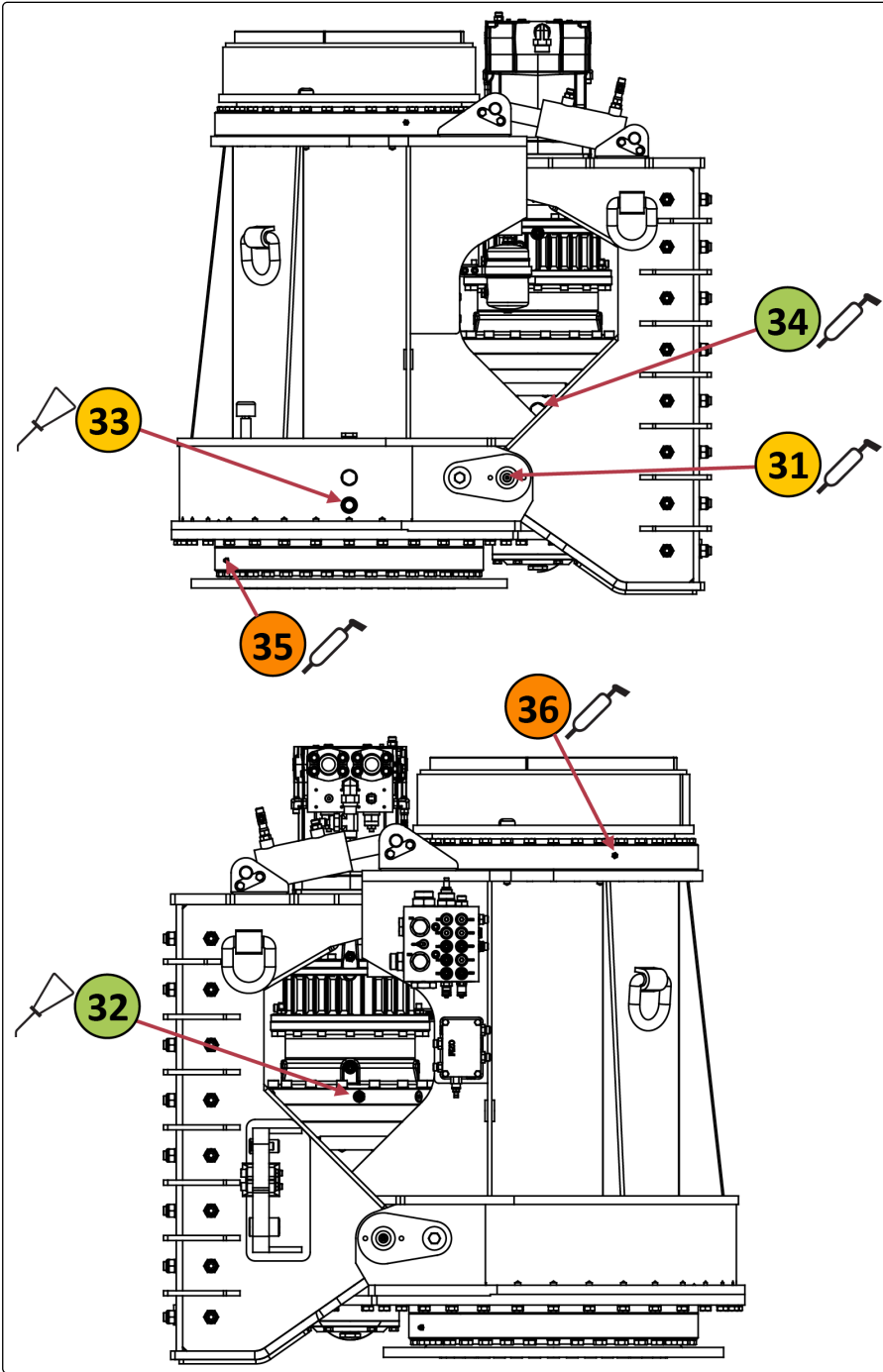

0000515 Lubrication Points 4

12.7. BASE MACHINE MAINTENANCE

12.7.1. Engine*



WARNING

Refer to the Engine Manufacturer Manual for further information.

12.7.1.1. Engine Oil*

12.7.1.1.1. Checking the Engine Oil Level*

SMCS Code: 1000-535



WARNING

- Hot oil and hot components can cause personal injury.
- Do not allow hot oil to contact the skin.
- Also, do not allow hot components to contact the skin.



IMPORTANT

Do not underfill or overfill the engine crankcase with oil. Either condition can cause engine damage.

This machine is equipped with an automated function for checking fluid levels and dipsticks. Refer to [Section: "CAT Monitoring System"](#) (page 232) regarding the automated system.

If the machine is on an incline or the engine has been stopped only for a short time, all engine oil may not be in the crankcase. The fluid level cannot be properly checked by either method during these instances. Park the machine on level ground.

The engine oil level can be checked after the engine has been stopped for at least 30 minutes. Do not check the oil level while the engine is running.

The machine is equipped with a ground-level dipstick and a dipstick on the top of the engine.

12.7.1.1.1.1. Engine Dipstick*

1. Open the access door on top of the machine. Refer to [Access Door and Hood Locations*](#) (page 381).

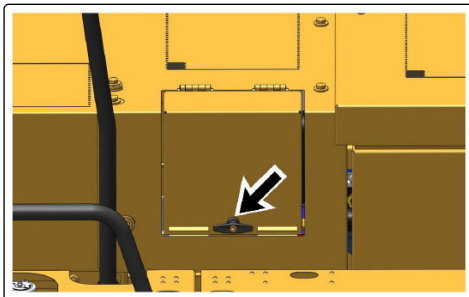

2. Remove dipstick (1). Wipe the oil off the dipstick and reinsert the dipstick.

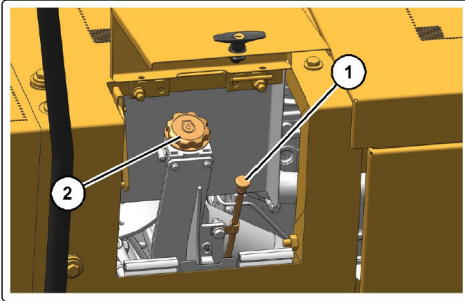

3. Remove the dipstick and check the dipstick.
The oil level should be between the “L” mark and the “H” mark.

IMPORTANT

Operating your engine when the oil level is above the “H” or “FULL” mark could cause the crankshaft to dip into the oil.

This will lead to excessively high oil temperatures which can reduce the lubricating characteristics of the oil, lead to bearing damage, and could result in loss of engine power.

Refer to [Containing Fluid Spillage*](#) (page 84) for more information.

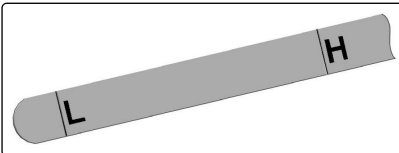

4. Remove oil filler plug (2) to add oil, if necessary. See [Section: “Fluids and Lubricants”](#) (page 400).

IMPORTANT

If the oil is deteriorated or is badly contaminated, change the oil regardless of the maintenance interval.

5. Clean the oil filler plug. Install the oil filler plug.
6. Close the access door.

12.7.1.1.1.2. Ground Level Dipstick*

To access the ground-level dipstick, open the right access door.

Figure 236.

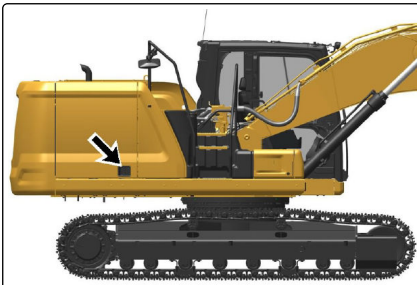

g06182545 Right Access Door

The ground-level dipstick is located near the engine oil filter and main hydraulic pump.

Figure 237.

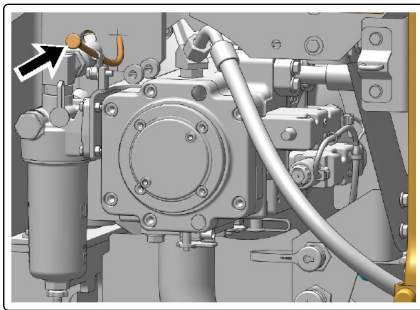

g06211545 Engine Oil Level-Ground Level Dipstick

12.7.1.1.2. Obtaining the Engine Oil Sample*

SMCS Code: 1000-008; 1000; 1348-554-SM; 1348-008; 7542-008; 7542-554-OC; 7542-554-SM

Obtain a sample of the engine oil from the engine oil sampling valve that is located on the engine oil filter housing. If needed, contact CZM for more information about obtaining a sample of the engine oil.

Figure 238.

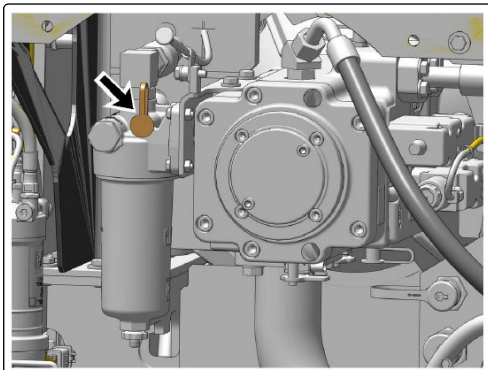

g06220379 Engine Oil Sampling Valve

12.7.1.1.3. Changing the Engine Oil and Filter*

SMCS Code: 1318-510

12.7.1.1.3.1. Selection of the Oil Change Interval*

i NOTICE
 Machines equipped with C7.1 engine and have a fuel burn average of 11.4 L (3 US gal) per hour or less may extend engine oil and filter interval from 500 hours to 1000 hours when using specific fluids, filters, and services.
 Contact CZM for more information.

Required oil sampling interval is every 250 hours.

Initial engine oil and filter change at 500 hours is required for engine break-in.

12.7.1.1.3.2. Procedure for Changing Engine Oil and Filter*



WARNING

- Hot oil and hot components can cause personal injury.
- Do not allow hot oil to contact the skin.
- Also, do not allow hot components to contact the skin.



NOTICE

If the sulfur content in the fuel is greater than 1.5 percent by weight, use an oil that has a Total Base Number (TBN) of 30 and reduce the oil change interval by one-half.



IMPORTANT

Drain the crankcase while the oil is warm.

This allows waste particles that are suspended in the oil to drain. As the oil cools, the waste particles will settle to the bottom of the crankcase.

The particles will not be removed by draining the oil and the particles will recirculate in the engine lubrication system with the new oil.

1. Prepare the machine for service. For more information refer to *Prepare the Machine for Maintenance** (page 384).
2. Open the crankcase drain valve. Allow the oil to drain into a suitable container. Refer to *Containing Fluid Spillage** (page 84) for more information.

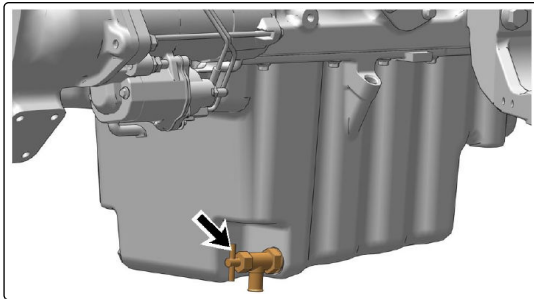

3. Close the drain valve.
4. Open the access door on the right side of the machine.

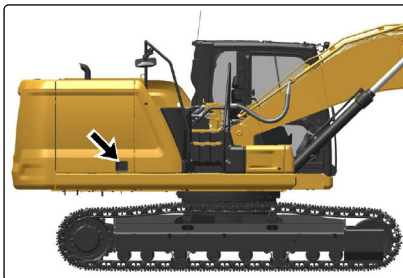

- Loosen the drain valve and allow the oil to drain out of the housing. The drain valve is on the bottom of the engine oil filter housing.



NOTICE

If equipped with a fast fill system, the oil can be drained and filled using the fast fill coupler. Refer to *Fast Fill (If Equipped)** (page 419).

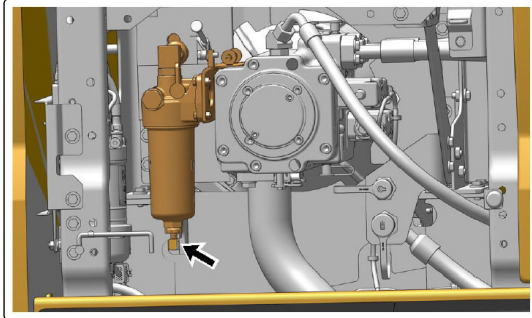

- Remove the oil filter housing. See *Section: "Inspecting the Oil Filter for Debris*"* (page 465). Dispose of the used filter according to local regulations.
- Remove the filter from the housing.

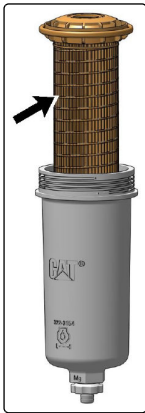

- Clean the filter housing and the base thread.
- Install the new filter element into the housing.
- After installing the new element, hand-tighten the drain valve at the bottom of the housing.
- Apply a thin coat of engine oil to the gasket of the filter. Refer to the illustration for lubrication points on the gasket.

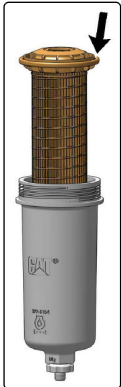

- Install the filter housing with element to the filter base utilizing a socket wrench.
Note: Apply a tightening torque of 90 N·m (66 lb·ft) and tighten until metal-to-metal contact is achieved.

13. Close the access door.
14. Open the access door on top of the machine. Refer to [Access Door and Hood Locations*](#) (page 381).

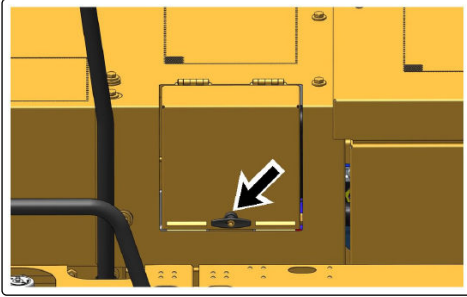

15. Remove oil filler cap (2). Fill the crankcase with new oil. See [Section: "Fluids and Lubricants"](#) (page 400). Clean the oil filler plug and install the oil filler plug.

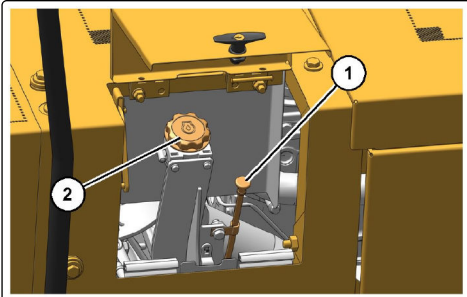
IMPORTANT

Do not underfill or overfill the engine crankcase with oil. Either condition can cause engine damage.

16. Start the engine and allow the oil to warm. Refer to [Engine Starting*](#) (page 286). Check the engine for leaks. Stop the engine.
17. Wait for 30 minutes to allow the oil to drain back into the crankcase. Check the oil level with oil level gauge (1). The oil level should be between the "L" mark and the "H" mark. If necessary, add oil.

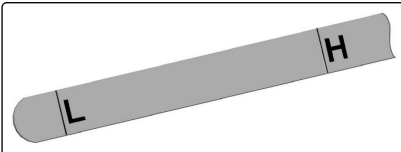

18. Close the access door.

12.7.1.1.3.3. Fast Fill (If Equipped)*

If your machine is equipped with a deluxe service center, you may drain and add the engine oil through the fast-fill port.

1. Open the access door on the right side of the machine.

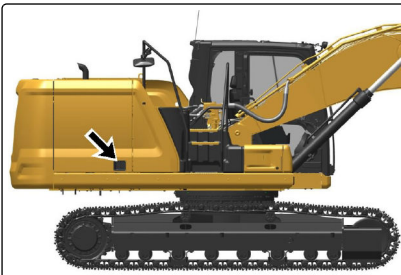

- Remove the dust cover.

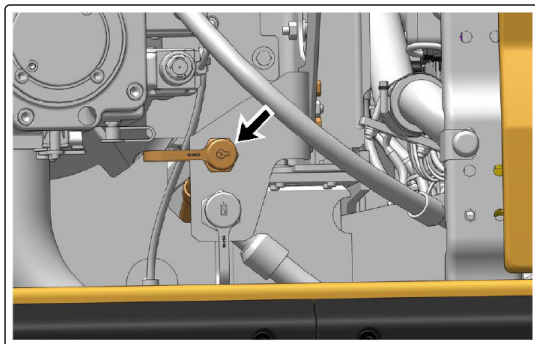

- Attach a hose that is equipped with a nozzle.
Note: Make sure that the nozzle and the receiver are free from debris before attaching.
- Drain the oil or add the oil, as needed.
- Install the dust cover.
- Verify that the correct amount of oil was added and add or remove oil as necessary. A ground-level dipstick is located in the same compartment as the fast-fill port.

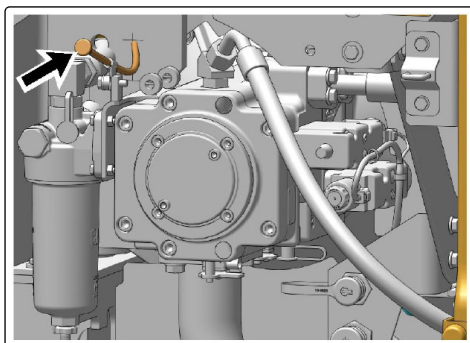

12.7.1.2. Engine Air Filter Primary and/or Secondary Element*

SMCS Code: 1054-510-PY; 1054-510-SE



IMPORTANT

Service the air cleaner only with the engine stopped.
Engine damage could result.



IMPORTANT

Service the engine air filter elements only when a message or a warning is displayed on the monitor display.
Do not open the filter compartment unless service is indicated.
Opening the filter compartment when not necessary to do so increases the chance of dirt contamination in engine air intake system components.



IMPORTANT

Short air filter life can result if the pre-cleaner system malfunctions.
If air filter life is drastically reduced from typical operating conditions, contact the CZM After Sales Department.

IMPORTANT

Do not use the air filter elements longer than 1 year.

12.7.1.2.1. Replacing the Primary Air Filter Element*

IMPORTANT

Ensure that the engine is stopped before any servicing or repair is performed.

The engine air cleaner assembly is located behind the front access door on the left side of the machine.

1. Park the machine on a level surface.
2. Stop the engine.
3. Open the front access door on the left side of the machine.

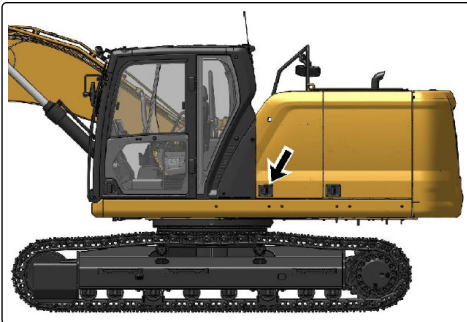

4. Squeeze outlet tube (1) to purge the dirt from the outlet tube.

Note: Purge the dirt from the outlet tube every 10 service hours or daily in a dirty environment.

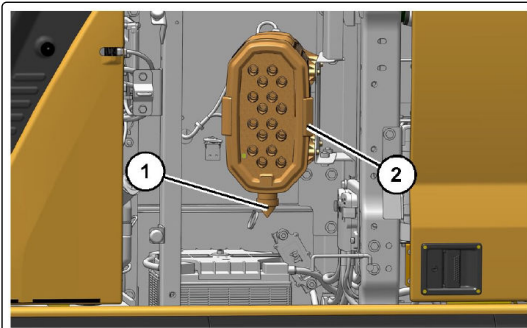

5. Release latches (2) that secure pre-cleaner (3) to engine air filter housing (6).

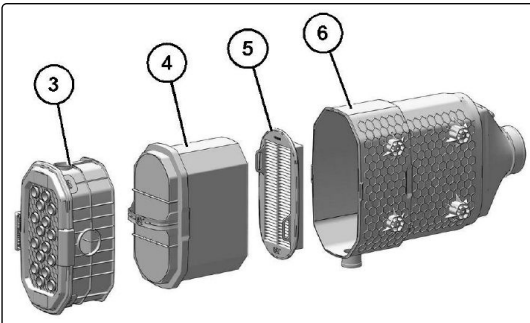

6. Remove pre-cleaner (3).
7. Clean inside the air filter housing where the pre-cleaner was removed.



IMPORTANT

CZM does not recommend cleaning the primary air filter element.
 CZM only recommends replacing the primary air filter element.
 CZM does not cover costs for damage to engine components caused by cleaning the primary air filter element.
 Observe the following guidelines if you attempt to clean the primary filter element:

- Do not tap or strike the filter element to remove dust.
- Do not wash the filter element.
- Use low-pressure compressed air to remove the dust from the filter element. Air pressure must not exceed 207 kPa (30 psi). Direct the airflow up the pleats and down the pleats from the inside of the filter element. Take extreme care to avoid damage to the pleats.
- Do not clean the air filter element more than three times. The air filter element must be replaced if the filter has been in use for one year, regardless of the number of times the filter has been cleaned.
- Do not use air filters with damaged pleats, gaskets, or seals. Dirt entering the engine will cause damage to engine components.



IMPORTANT

Do not clean the air filter elements by bumping or tapping. This could damage the seals.
 Do not use elements with damaged pleats, gaskets, or seals. Damaged elements will allow dirt to pass through.
 Engine damage could result.

8. Remove the primary air filter element (4). Replace the filter element as necessary.
Note: Replace the primary filter if the filter has been in use for 1 year.
9. Clean inside the air filter assembly housing.
Note: Do not allow any dirt or debris to contact the secondary air filter element (5).
10. Inspect the seal area to ensure that no foreign debris has fallen into the seal area. Clean the air cleaner interior to remove remaining dust or debris.
11. Without removing the secondary air filter element (5), inspect the filter element for damage. Replace if necessary or dirty. Refer to [Section: “Replacing the Secondary Air Filter Element*” \(page 422\)](#).
12. Install the secondary air filter element.
13. Install the primary filter.



IMPORTANT

Filters must be fully installed before the pre-cleaner can be attached.
 If the pre-cleaner cannot be fully latched, verify that the filter elements are properly seated.

14. Install the pre-cleaner and secure the latches that hold the pre-cleaner to the air filter housing.
15. Close the access door.

12.7.1.2.2. Replacing the Secondary Air Filter Element*



IMPORTANT

Always replace the secondary element. Do not attempt to reuse it by cleaning it.
 Engine damage could result.



IMPORTANT

Do not use the air filter elements longer than 1 year.

IMPORTANT

Replace the secondary filter element when you service the primary element for the third time. If a clean primary element has been installed and the filter element indicator is still flashing, replace the secondary filter element. Also if the exhaust smoke remains black and a clean primary filter element has been installed, replace the secondary filter element.

1. Open the front access door on the left side of the machine.
2. Refer to [Section: "Replacing the Primary Air Filter Element*" \(page 421\)](#). Remove the pre-cleaner from the engine air filter housing. Remove the primary air filter element from the air filter housing.
3. The secondary air filter element (5) is pressed into the rear portion of the engine air filter housing (6). Pull forward on the secondary air filter element to remove the element from the engine air filter housing.

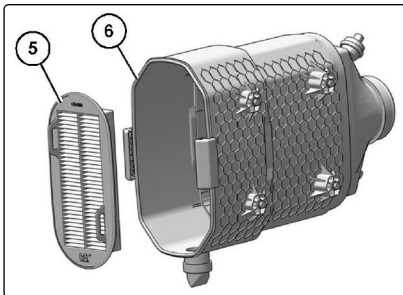

4. Cover the air inlet opening. Clean inside the air cleaner housing.
5. Clean all surfaces of the pre-cleaner cover and body.
6. Uncover the air inlet opening.
7. Carefully press the secondary air filter element into the rear portion of the engine air filter housing.

IMPORTANT

Be certain that the new secondary air filter element is properly seated in the filter housing. Also, check to see that no damage to the filter element has occurred during installation.

8. Install the primary air filter element and the pre-cleaner.
9. Close the access door.

12.7.1.2.3. Cleaning the Engine Air Pre-Cleaner*

IMPORTANT

Do not attempt to clean the pre-cleaner by hitting the filter against another object. Damage to the filter is likely to occur.

Figure 239.

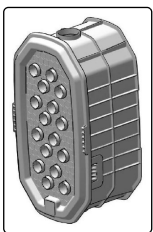

g06183310 Engine Air Pre-Cleaner

After removing the pre-cleaner from the air filter housing, inspect the interior of the pre-cleaner through the ejection ports around the perimeter.

In general, dust and debris will clear automatically through normal pre-cleaner operation and no further service will be required.

If the ejection ports are blocked, or dust is packed between the pre-cleaner tubes, first try to clear any accumulation by vigorously shaking the pre-cleaner.

If the pre-cleaner is still blocked with dirt, the pre-cleaner may be separated by releasing the snap features holding the front cover to the pre-cleaner body.

1. Place the pre-cleaner assembly on a suitable work surface. The interior of the pre-cleaner may have accumulated debris. Protect your work surface to collect excess debris and to avoid scattering debris.



2. Lift the locking tabs on one end of the cover away from the retainers. Move the locking tabs only far enough to clear the retention posts.



IMPORTANT

Do not bend the locking tabs farther than necessary to release the tabs. Damage to the air cleaner can result. Do not use tools to force the snap features off the retainers.

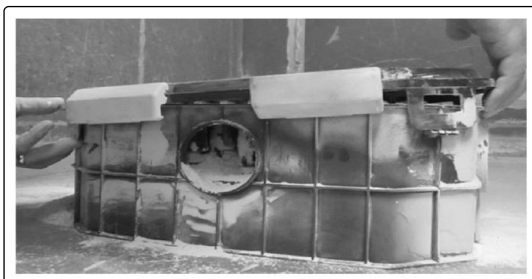

3. Pull one end of the top cover away from the bottom half.
4. Hold one end of the cover sections apart and separate one of the locking tabs on the other end of the pre-cleaner.
5. Pull the top cover up and away from the bottom.

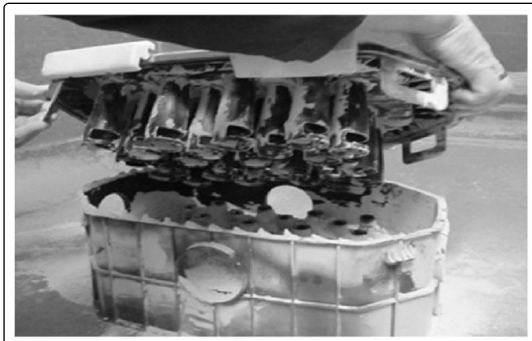

6. Clear any blockage by shaking the pre-cleaner components and/or brushing away accumulated debris.

IMPORTANT

Do not use picks or other stiff implements to clear debris, you may damage the pre-cleaner components.

IMPORTANT

Do not attempt to remove the pre-cleaner tubes from the top cover or you will damage the air cleaner.

7. If the blockage is still not cleared, you may attempt to clear the debris by use of an air nozzle limited to 207 kPa (30 psi).

Alternately, each part of the pre-cleaner may be submerged in water to loosen mud or other debris that may have dried on the interior surface of the air cleaner.

IMPORTANT

Never attempt to use a pressure washer or other high-pressure water sources to clean the pre-cleaner.

The use of high-pressure water may damage the pre-cleaner tubes and reduce the pre-cleaner effectiveness.

8. After cleaning, reassemble the pre-cleaner by lining up the tubes on the pre-cleaner top with the tubes in the pre-cleaner bottom.
9. Allow the pre-cleaner top to rest on the pre-cleaner bottom and ensure that the four snap features are aligned.
10. If all the tabs are aligned, gently push the pre-cleaner top down into place. Ensure that all the snap features have engaged.



11. Before installing the pre-cleaner to the air filter housing, inspect the pre-cleaner gasket for damage. Replace if damaged.

12.7.1.3. Fumes Disposal Filter Element

12.7.1.3.1. Replacing the Fumes Disposal Filter Element*

SMCS Code: 1074



IMPORTANT

Ensure that the engine is stopped before any servicing or repair is performed.

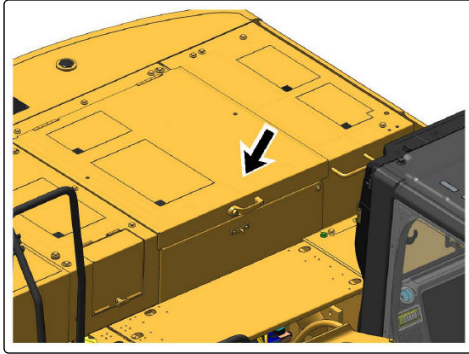
1. Open the engine hood. Refer to [Access Door and Hood Locations*](#) (page 381).

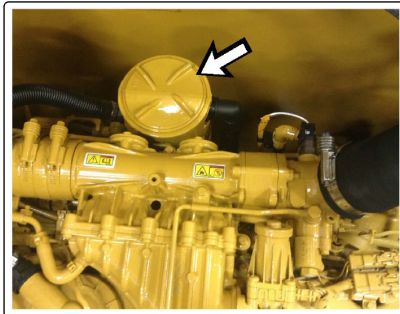

2. Remove the lid that holds the canister to the filter base assembly.



3. Remove the filter element. Dispose of the used element properly.
4. Install the new filter.
5. Install the lid.
6. Close the engine hood.

12.7.1.4. Cooling System Coolant (ELC)*



WARNING

The engine hood and engine hood parts can be hot while the engine is running or immediately after the engine shutdown.



WARNING

- Hot parts or hot components can cause burns or personal injury.
- Do not allow these parts to contact your skin when the engine is running or immediately after engine shutdown.
- Use protective clothing or protective equipment to protect your skin.

- When the engine is at operating temperature, the engine coolant is hot. The coolant is also under pressure.
- The radiator and all lines to the heaters or the engine contain hot coolant.
- Check the coolant level only after the engine has been stopped.
- Ensure that the filler cap is cool before removing the filler cap. The filler cap must be cool enough to touch with a bare hand. Remove the filler cap slowly in order to relieve pressure.
- Do not attempt to tighten hose connections when the coolant is hot, the hose can come off causing burns.



WARNING

- Any contact with hot coolant or with steam can cause severe burns. Allow cooling system components to cool before the cooling system is drained.
- The cooling system conditioner contains alkali. Alkali can cause personal injury. Do not allow alkali to contact the skin, the eyes, or the mouth.

12.7.1.4.1. Changing the Cooling System Coolant (ELC)*

SMCS Code: 1350-044



IMPORTANT

Do not change the coolant until you first contact the CZM After Sales Department for machine fluid recommendations.

Failure to do so could result in damage to the cooling system components.



IMPORTANT

Mixing ELC with other products will reduce the effectiveness of the coolant.

This could result in damage to cooling system components.

If CZM recommended products are not available and commercial products must be used, contact CZM After Sales Department for approval of premixed or concentrate coolants and extenders.



NOTICE

This machine was filled at the factory with Extended Life Coolant.

If the coolant in the machine is changed to Extended Life Coolant from another type of coolant, contact the CZM After Sales Department for recommendations.

1. Unlatch the engine hood and raise it.

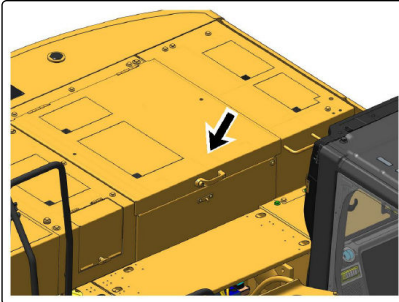

2. Slowly loosen the pressure cap that is on the coolant reservoir to release pressure from the cooling system.

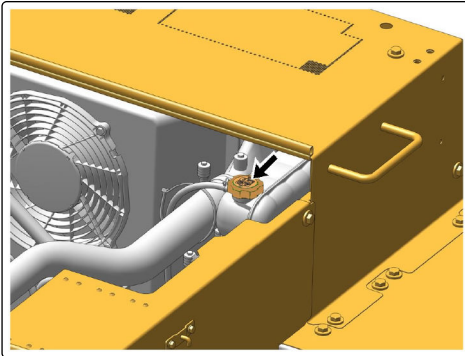

3. Remove the pressure cap.
4. Inspect the gasket on the pressure cap. If the gasket is damaged, replace the pressure cap.

5. Open the rear access door on the left side of the machine.

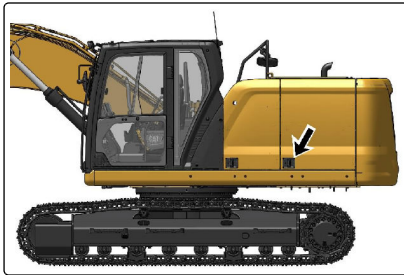

6. Open the drain valve and allow the coolant to drain into a suitable container. The drain valve is on the bottom of the radiator. Properly dispose of used coolant.

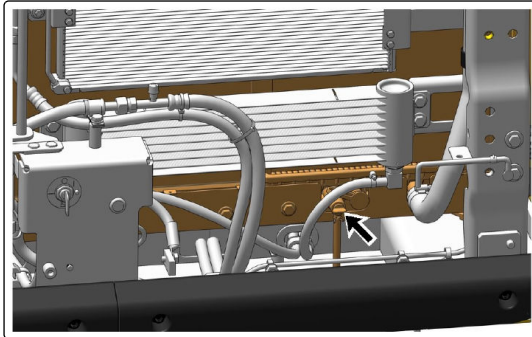

7. Flush the cooling system. Follow these steps to flush the cooling system.
 - a. Close the drain valve.
 - b. Fill the cooling system with clean water.
 - c. Install the pressure cap.
 - d. Start the engine and run the engine until the engine reaches operating temperature.



IMPORTANT

Do not run the engine with plain water in the cooling system for more than 5 min. The water may vaporize and trapped air may damage the NRS cooler.

- e. Stop the engine and allow the engine to cool.
 - f. Loosen the pressure cap slowly to relieve any pressure in the cooling system.
 - g. Open the drain valve that is on the bottom of the radiator and allow the coolant to drain into a suitable container.
 - h. Flush the radiator with clean water until the draining water is transparent.
8. Close the drain valve.
9. Add the Extended Life Coolant. For more information refer to [Section: "Fluids and Lubricants" \(page 400\)](#).
10. After the cooling system has been filled, perform the following procedures during the initial start-up:
 - a. Start the engine without the filler cap.
 - b. Run the engine at low idle for 10 minutes.
 - c. Then, increase the engine speed to a high idle until the water temperature regulator is open and the coolant level is stabilized.
 - d. Maintain the coolant at the proper level as the water temperature regulator opens and air is purged from the system. For more information refer to [Section: "Checking the Cooling System Coolant Level*" \(page 430\)](#).
11. Install the cooling system pressure cap.
12. Stop the engine.

13. Check the coolant reservoir. Maintain the coolant level so that coolant is between the “ADD” and “FULL” lines. If more coolant is needed, see [Section: “Adding the Cooling System Coolant Extender \(ELC\)* ” \(page 429\)](#).

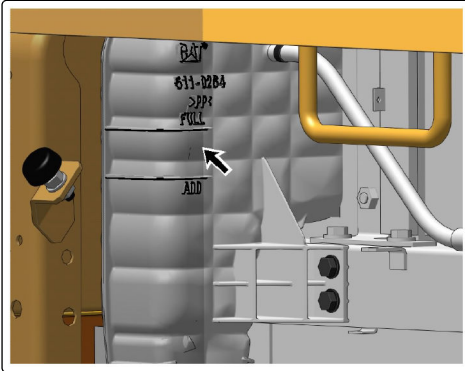

14. If more coolant is necessary, remove the pressure cap and add the appropriate coolant solution.
15. Install the pressure cap.
16. Close and latch the engine hood. Close the left access door.
17. Close and latch engine service door.

12.7.1.4.2. Adding the Cooling System Coolant Extender (ELC)*

SMCS Code: 1352; 1353; 1395

1. Park the machine on a level surface.
2. Stop the engine.
3. Unlatch the engine hood and raise it.

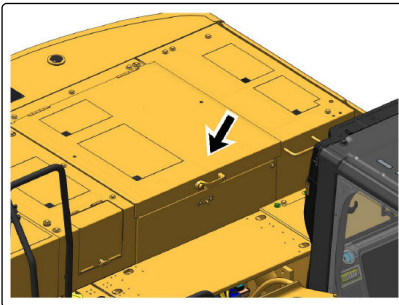

4. Make sure that the cooling system has cooled down. Loosen the cooling system pressure cap slowly to relieve system pressure. Remove the pressure cap.

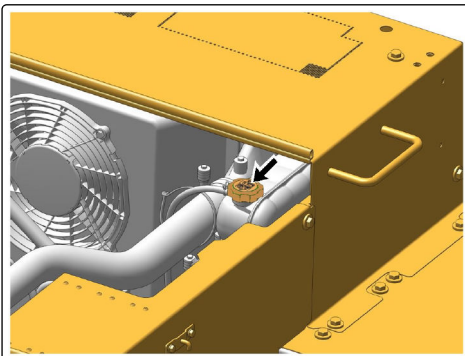

5. You may need to drain some coolant from the radiator so that a coolant extender can be added to the cooling system.



ENVIRONMENTAL NOTICE

Always discard drained fluids according to local regulations.

6. Add the Extended Life Coolant. For more information refer to *Section: “Fluids and Lubricants” (page 400)*.
7. Inspect the O-ring of the cooling system pressure cap. If the O-ring is damaged, replace the pressure cap.
8. Install the cooling system pressure cap.
9. Close and latch the engine hood. Close the left access door.

12.7.1.4.3. Checking the Cooling System Coolant Level*

SMCS Code: 1350-040; 1350-535-FLV; 1395-535-FLV

1. Park the machine on a level surface.
2. Stop the engine.
3. Open the rear access door on the left side of the machine.

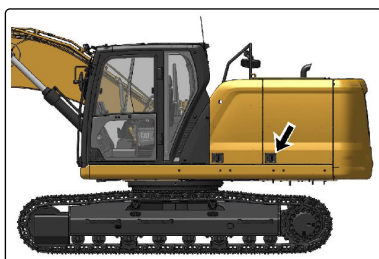

4. Check the coolant reservoir. Maintain the coolant level so that coolant is between the “ADD” and “FULL” lines. If more coolant is needed, see *Section: “Adding the Cooling System Coolant Extender (ELC)*” (page 429)*.

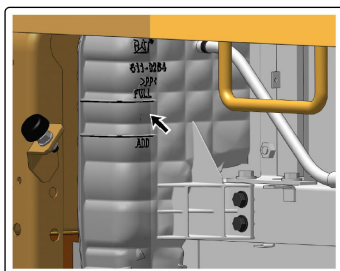

5. Close the access door.

12.7.1.4.4. Obtaining the Cooling System Coolant Sample (Level 1)*

SMCS Code: 1395-554; 1395-008; 7542



NOTICE

It is not necessary to obtain a Coolant Sample (Level 1) if the cooling system is filled with ELC (Extended Life Coolant). Cooling systems that are filled with ELC should have a Coolant Sample (Level 2) that is obtained at the recommended interval that is stated in the Maintenance Interval Schedule.

Obtain a Coolant Sample (Level 1) if the cooling system is filled with any other coolant instead of an ELC coolant. This includes the following types of coolants:

- Commercial long-life coolants.
- Diesel Engine Antifreeze/Coolant (DEAC).
- Commercial heavy-duty coolant/antifreeze.

Level 1 results may indicate a need for Level 2 Analysis.



IMPORTANT

Always use a designated pump for oil sampling, and use a separate designated pump for coolant sampling.

Using the same pump for both types of samples may contaminate the samples that are being drawn.

This contamination may cause a false analysis and an incorrect interpretation that could lead to concerns by both dealers and customers.



ENVIRONMENTAL NOTICE

- Make sure that fluids are contained while performing inspection, maintenance, testing, adjusting, and repairs on the machine.
- Be prepared to collect any fluids with suitable containers before opening any lines or components containing fluids.
- Dispose of all fluids according to local regulations and mandates.
- Contact the CZM After Sales Department for tools and supplies suitable to collect and contain fluids on CZM products.

Improper waste disposal can harm the environment.

The coolant sampling port is on the radiator.

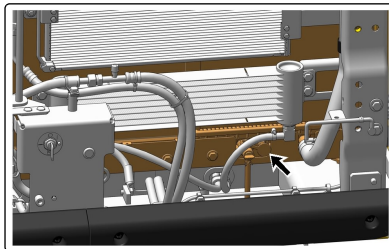

Obtain the sample of the coolant as close as possible to the recommended sampling interval.

To receive the full effect of S-O-S analysis, a consistent trend of data must be established.

To establish a pertinent history of data, perform consistent samplings that are evenly spaced.

Supplies for collecting samples can be obtained from CZM.

Use the following guidelines for proper sampling of the coolant:

- Complete the information on the label for the sampling bottle before you begin to take the samples.
- Keep the unused sampling bottles stored in plastic bags.
- Obtain coolant samples directly from the coolant sample port. You should not obtain the samples from any other location.
- Keep the lids on empty sampling bottles until you are ready to collect the sample.
- Place the sample in the mailing tube immediately after obtaining the sample to avoid contamination.
- Never collect samples from expansion bottles.
- Never collect samples from the drain for a system.

Submit the sample for Level 1 analysis.

For additional information about coolant analysis, contact CZM.

12.7.1.4.5. Obtaining the Cooling System Coolant Sample (Level 2)*

SMCS Code: 1395-008; 1395-554; 7542

Refer to [Section: "Obtaining the Cooling System Coolant Sample \(Level 1\)*" \(page 430\)](#) for the guidelines for proper sampling of the coolant.

Obtain the sample of the coolant as close as possible to the recommended sampling interval.

Supplies for collecting samples can be obtained from CZM.
 For additional information about coolant analysis, contact CZM.

12.7.1.5. Belt

12.7.1.5.1. Inspecting/Adjusting/Replacing the Belt

SMCS Code: 1357-040; 1357-510; 1357-025; 1397-025; 1397-040; 1397-510

i NOTICE
 This engine is equipped with a belt tightener that automatically adjusts the belt to the correct tension.

1. Unlatch the engine hood and raise the engine hood.
2. Inspect the condition of the serpentine belt. Over time the belt ribs will lose material (C). The space between the ribs will increase (D). The loss of material will cause the pulley sheave to contact the belt valley. This will lead to belt slippage and accelerated wear (E). Replace the belt if the belt is worn or frayed.

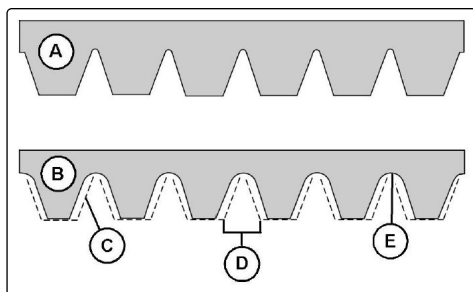

3. If the belt requires replacement, perform Step 3a through Step 3f.
 - a. Remove the upper fan guard.
 - b. Rotate the belt tensioner clockwise to remove the belt.

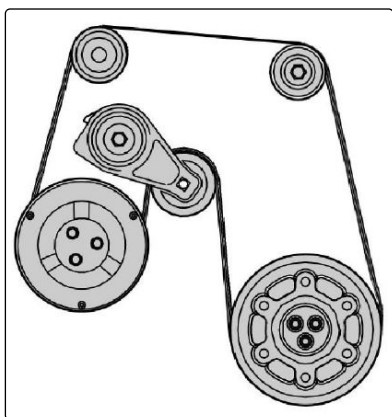

- c. Remove the belt.
- d. Install a new belt.
- e. Rotate the belt tensioner clockwise to install the belt.
- f. Install the upper fan guard.
- g. Close and latch the engine hood.

12.7.2. Fuel System*

12.7.2.1. Replacing the Fuel Tank Cap Filter*

SMCS Code: 1261-510

Figure 240.

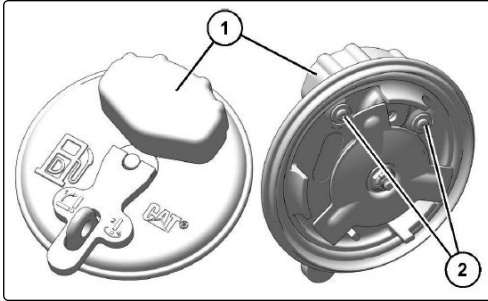

g06220524 Fuel System-Fuel Cap

1. Remove the fuel cap.
2. Remove filter element screws (2) from the underside of the fuel cap and remove filter element (1).
3. Install a clean fuel cap filter element.
4. Install the screws to secure the filter element to the fuel cap.
5. Install the fuel tank cap.

12.7.2.2. Replacing the Fuel Lift Pump Strainer (In-line Filter)*

SMCS Code: 1256; 1256-510-STR



WARNING

- Fuel leaked or spilled onto hot surfaces or electrical components can cause a fire.
- Clean up all leaked or spilled fuel. Do not smoke while working on the fuel system.
- Turn the disconnect switch OFF or disconnect the battery when changing fuel filters or water separator elements.

Failure to follow this warning could result in death or serious injury.



IMPORTANT

- Do not fill the fuel filters with fuel before installing the fuel filters.
- The fuel will not be filtered and could be contaminated.
- Contaminated fuel will cause accelerated wear to fuel system parts.

The fuel lift pump strainer is located behind the access door on the right side of the machine.

Figure 241.

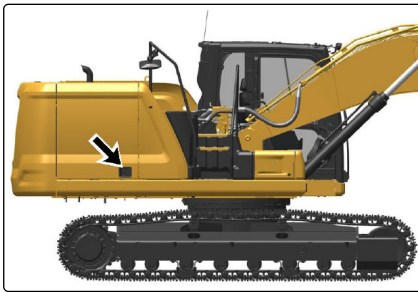

g06182545 Right Access Door

1. Open the access door and close the fuel shut-off valve (2) by turning the valve clockwise.

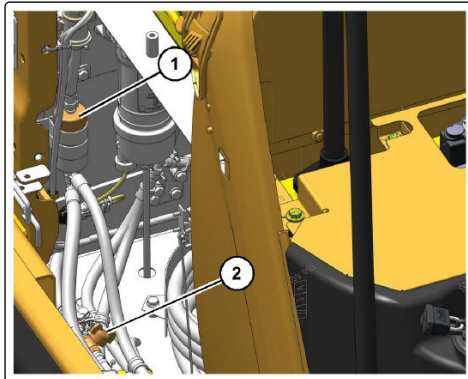

2. Disconnect the hoses from the strainer (1) and remove the strainer.
3. Install a new strainer, and reconnect the hoses.
4. Open the fuel shut-off valve by turning the valve counterclockwise.

12.7.2.3. Priming the Fuel System*

SMCS Code: 1250-548



WARNING

- Fuel leaked or spilled onto hot surfaces or electrical components can cause a fire.
- Clean up all leaked or spilled fuel. Do not smoke while working on the fuel system.
- Turn the disconnect switch OFF or disconnect the battery when changing fuel filters or water separator elements.

Failure to follow this warning could result in death or serious injury.



ENVIRONMENTAL NOTICE

- Make sure that fluids are contained while performing inspection, maintenance, testing, adjusting, and repairs on the machine.
- Be prepared to collect any fluids with suitable containers before opening any lines or components containing fluids.
- Dispose of all fluids according to local regulations and mandates.
- Contact the CZM After Sales Department for tools and supplies suitable to collect and contain fluids on CZM products.

Improper waste disposal can harm the environment.

IMPORTANT

Do not loosen the fuel lines at the fuel manifold.

The fittings may be damaged and/or a loss of priming pressure may occur when the fuel lines are loosened.

IMPORTANT

Do not allow dirt to enter the fuel system. Dirt or water in the system can cause severe damage to both the fuel pump and the fuel injectors.

Thoroughly clean the area around a fuel system component that will be disconnected.

Fit a suitable cover over any disconnected fuel system components.

Prime the fuel system to fill the fuel filter, and prime the fuel system to purge trapped air.

The fuel system should be primed under the following conditions:

- The fuel tank is running low.
 - The machine has been stored.
 - The fuel filter is being replaced.
1. Turn the engine start switch to the ON position. Leave the engine start switch in the ON position for 2 minutes.
 2. Verify that the water separator is full of fuel.
 3. If the water separator is not full of fuel, turn the engine start switch OFF and then turn the engine start switch ON. Turning the engine start switch off and on will cycle the fuel priming pump again.
 4. When the water separator is full of fuel, attempt to start the engine. If the engine starts and the engine runs rough or the engine misfires, operate at low idle until the engine is running smoothly. If the engine cannot be started, or if the engine continues to misfire or smoke, repeat Step 1.

12.7.2.4. Replacing the Fuel System Primary Filter (Water Separator) Element*

SMCS Code: 1263-510-FQ

WARNING

- Fuel leaked or spilled onto hot surfaces or electrical components can cause a fire.
- Clean up all leaked or spilled fuel. Do not smoke while working on the fuel system.
- Turn the disconnect switch OFF or disconnect the battery when changing fuel filters or water separator elements.

Failure to follow this warning could result in death or serious injury.

IMPORTANT

Do not fill the fuel filters with fuel before installing the fuel filters.

The fuel will not be filtered and could be contaminated.

Contaminated fuel will cause accelerated wear to fuel system parts.

12.7.2.4.1. CAT 323

Procedure For:

- **S/N:** HEX1–10000
- **S/N:** RAZ1–10000

The primary filter/water separator is located behind the access door on the right side of the machine.

1. Open the access door on the right side of the machine.

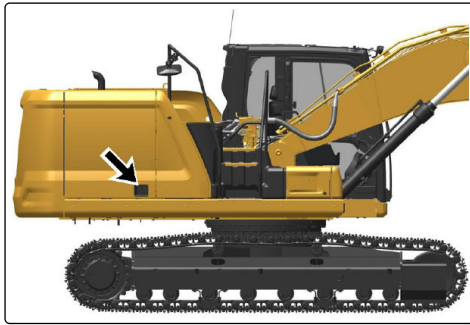

2. Turn drain valve (4) counterclockwise to open. The drain valve is on the bottom of the water separator.

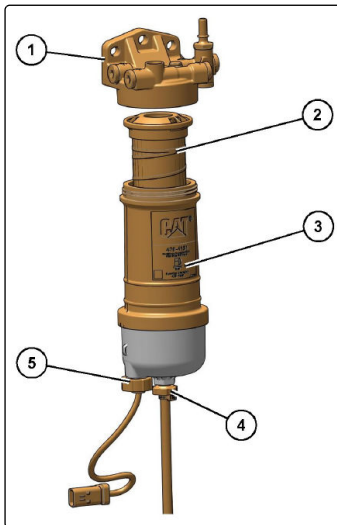

3. Drain the water and the sediment into a suitable container.
4. Close the drain valve (4).
5. Disconnect the water sensor (5) from the harness.



IMPORTANT

Do not attempt to remove the sediment bowl from the housing. The sediment bowl is permanently attached to the housing. Attempting to remove the sediment bowl may damage the bowl.

6. Unscrew filter housing (3) and remove primary filter (2). A filter wrench may be used to loosen the filter housing. Properly discard the used filter.
7. Clean the mounting base (1).
8. Lubricate the seal of the new filter (2) with clean diesel fuel.
9. Install the new filter (2) into the housing.
10. Tighten the filter housing approximately 1/6 of a turn. Do not use tools to tighten the filter housing to the filter base.
11. Ensure that sensor (5) is in the correct position and connect to the wiring harness. If the sensor was removed from the bowl, install the sensor and tighten to $2.5 \pm 0.5 \text{ N}\cdot\text{m}$ ($22 \pm 4 \text{ lb in}$).
12. Open the fuel shutoff valve.
13. Close the access door.

Procedure For:

- S/N: KFE1–Up
- S/N: MYK1–Up

- S/N: NDL1–Up
- S/N: LTN1–Up
- S/N: YCP1–Up
- S/N: HDT1–Up
- S/N: HEX10001–Up
- S/N: RAZ10001–Up

The primary filter/water separator is located behind the access door on the right side of the machine.

1. Open the access door on the right side of the machine.

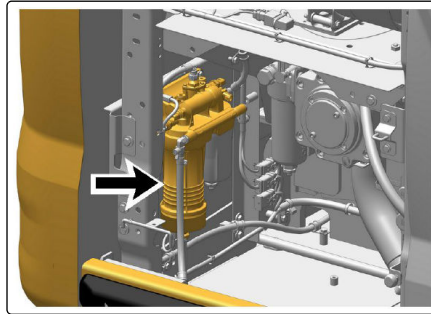
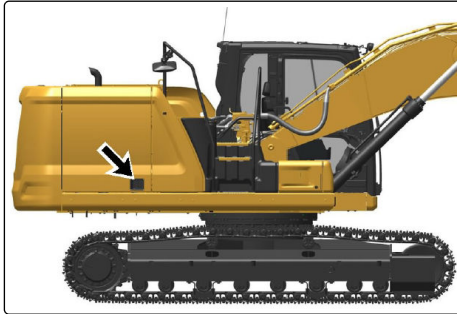

2. Turn drain valve (4) counterclockwise to open. The drain valve is on the bottom of the water separator. Refer to [Containing Fluid Spillage*](#) (page 84) for more information.

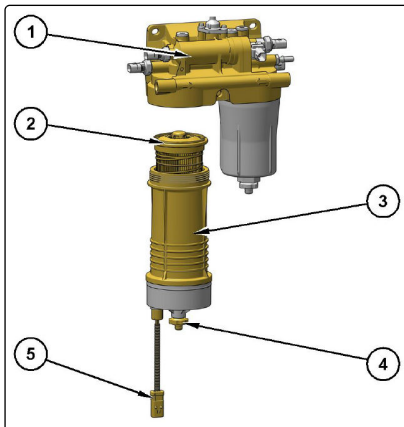

3. Drain the water and the sediment into a suitable container.
4. Close the drain valve (4).
5. Disconnect the water sensor (5) from the harness.

IMPORTANT

Do not attempt to remove the sediment bowl from the housing. The sediment bowl is permanently attached to the housing. Attempting to remove the sediment bowl may damage the bowl.

6. Unscrew filter housing (3) and remove primary filter (2). A filter wrench may be used to loosen the filter housing. Properly discard the used filter.
7. Clean the mounting base (1).
8. Lubricate the seal of the new filter (2) with clean diesel fuel.
9. Install the new filter (2) into the housing.
10. Tighten the filter housing approximately 1/6 of a turn. Do not use tools to tighten the filter housing to the filter base.

11. Ensure that sensor (5) is in the correct position and connect to the wiring harness. If the sensor was removed from the bowl, install the sensor and tighten to 2.5 ± 0.5 N·m (22 ± 4 lb in).
12. Open the fuel shutoff valve.
13. Close the access door.

12.7.2.5. Replacing the Fuel System Secondary Filter*

SMCS Code: 1261-510



WARNING

- Fuel leaked or spilled onto hot surfaces or electrical components can cause a fire.
- Clean up all leaked or spilled fuel. Do not smoke while working on the fuel system.
- Turn the disconnect switch OFF or disconnect the battery when changing fuel filters or water separator elements.

Failure to follow this warning could result in death or serious injury.



IMPORTANT

Do not fill the fuel filters with fuel before installing the fuel filters.
The fuel will not be filtered and could be contaminated.
Contaminated fuel will cause accelerated wear to fuel system parts.



IMPORTANT

Do not allow dirt to enter the fuel system. Dirt or water in the system can cause severe damage to both the fuel pump and the fuel injectors.
Thoroughly clean the area around a fuel system component that will be disconnected.
Fit a suitable cover over any disconnected fuel system components.



ENVIRONMENTAL NOTICE

- Make sure that fluids are contained while performing inspection, maintenance, testing, adjusting, and repairs on the machine.
- Be prepared to collect any fluids with suitable containers before opening any lines or components containing fluids.
- Dispose of all fluids according to local regulations and mandates.
- Contact the CZM After Sales Department for tools and supplies suitable to collect and contain fluids on CZM products.

Improper waste disposal can harm the environment.

12.7.2.5.1. CAT 323

Procedure For:

- S/N: HEX1–10000
- S/N: RAZ1–10000

1. Open the access door on the right side of the machine.

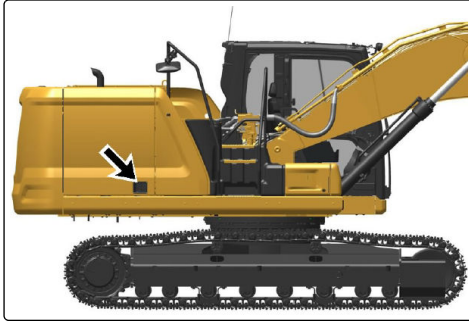

2. Shut off the fuel supply.
Refer to [Stop the Engine if an Electrical Malfunction Occurs*](#) (page 316) for additional information on the fuel shut off valve.
3. Loosen drain valve (2) and allow the fuel to drain out of the housing into a suitable container.
Refer to [Containing Fluid Spillage*](#) (page 84) for more information.

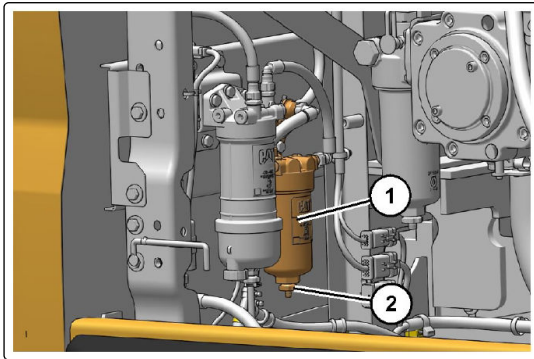

4. After all the fuel has been removed, tighten the drain.
5. Remove the secondary fuel filter housing (1) from the base.
6. Remove the filter element from the housing.
7. Clean the filter housing and the base.
8. Install the new filter element into the housing.
9. Apply a thin coat of clean diesel fuel to the sealing surface of the new fuel filter.
10. Install the new filter and tighten by hand.

Procedure For:

- S/N: KFE1–Up
- S/N: MYK1–Up
- S/N: NDL1–Up
- S/N: LTN1–Up
- S/N: YCP1–Up
- S/N: HDT1–Up
- S/N: HEX10001–Up
- S/N: RAZ10001–Up

1. Open the access door on the right side of the machine.

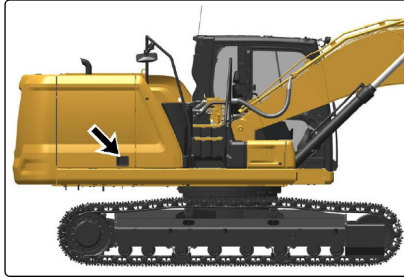

2. Shut off the fuel supply.
Refer to *Stop the Engine if an Electrical Malfunction Occurs** (page 316) for additional information on the fuel shut off valve.
3. Loosen drain valve (2) and allow the fuel to drain out of the housing into a suitable container.
Refer to *Containing Fluid Spillage** (page 84) for more information.

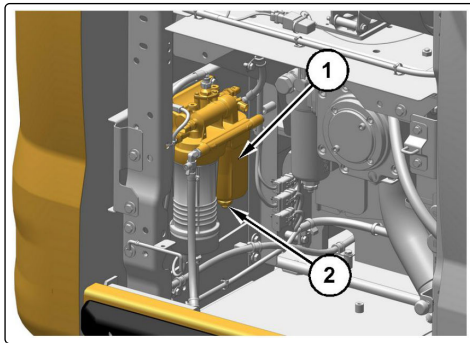

4. After all the fuel has been removed, tighten the drain.
5. Remove the secondary fuel filter housing (1) from the base.
6. Remove the filter element from the housing.
7. Clean the filter housing and the base thread.
8. Install the new filter element into the housing.
9. Apply a thin coat of clean diesel fuel to the sealing surface of the new fuel filter.
10. Install the new filter and tighten to 50 +/- 5 N·m (36.9 +/- 4 ft lb).
11. Turn on the fuel supply.
12. Close the access door.

12.7.2.6. Draining the Fuel System Water Separator*

SMCS Code: 1263



ENVIRONMENTAL NOTICE

- Make sure that fluids are contained while performing inspection, maintenance, testing, adjusting, and repairs on the machine.
- Be prepared to collect any fluids with suitable containers before opening any lines or components containing fluids.
- Dispose of all fluids according to local regulations and mandates.
- Contact the CZM After Sales Department for tools and supplies suitable to collect and contain fluids on CZM products.

Improper waste disposal can harm the environment.

12.7.2.6.1. CAT 323, CAT 330

1. Open the access door on the right side of the machine.

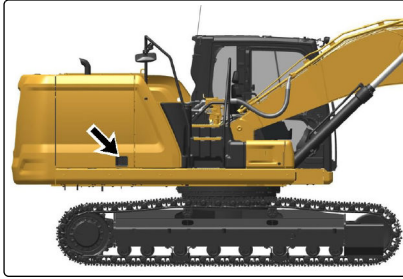

- Open drain valve (1) on the bottom of the fuel/water separator element. Drain the water into a suitable container.

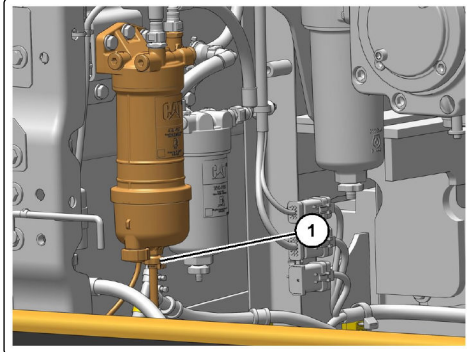

- Close the drain valve when all the water has been drained.



IMPORTANT

When water is not drained from the primary filter sufficiently, water will collect in the secondary fuel filter.

Trapped water will eventually overflow.

Draining water from the secondary fuel filter will prevent water from damaging the fuel system.

The procedure for the secondary filter is the same as the primary filter.

- Close the access door.

12.7.2.7. Cleaning the Fuel Tank Strainer*

SMCS Code: 1273-070-STR

Figure 242.

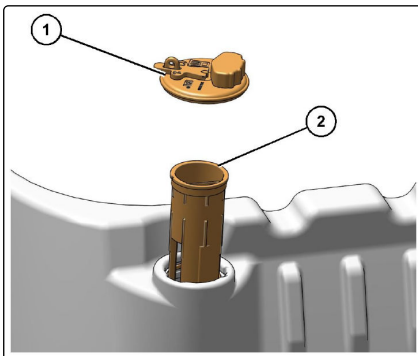

g06183008 Fuel System-Strainer

- Remove the fuel tank cap (1).
- Remove strainer (2) from the filler opening.

3. Wash the strainer in a clean, nonflammable solvent.
4. Install the strainer into the filler opening.
5. Install the fuel tank cap.

12.7.2.8. Draining the Fuel Tank Water and Sediment*

SMCS Code: 1273-543

The drain valve for the fuel tank is located in the right compartment.

1. Open the access door on the right side of the machine.
Refer to *Containing Fluid Spillage** (page 84) for more information.

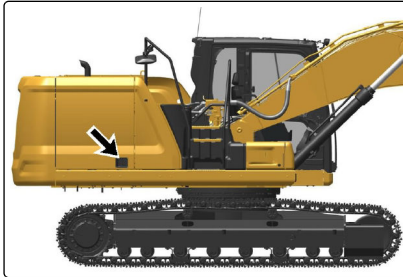

2. Open the drain valve by turning the valve counterclockwise. Allow the water and the sediment to drain into a suitable container.

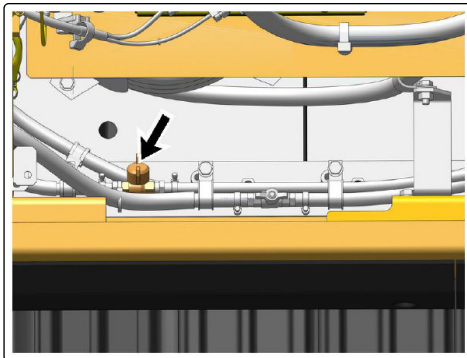

3. Close the drain valve by turning the valve clockwise.
4. Close the access door.

12.7.2.9. Diesel Exhaust Fluid (DEF)*

! **IMPORTANT**
Ensure that the engine is stopped before any servicing or repair is performed.

! **WARNING**

- Personal injury can result from improper handling of chemicals.
- Make sure you use all the necessary protective equipment required to do the job.
- Make sure that you read and understand all directions and hazards described on the labels and material safety data sheet of any chemical that is used.
- Observe all safety precautions recommended by the chemical manufacturer for handling, storage, and disposal of chemicals.



ENVIRONMENTAL NOTICE

- Make sure that fluids are contained while performing inspection, maintenance, testing, adjusting, and repairs on the machine.
- Be prepared to collect any fluids with suitable containers before opening any lines or components containing fluids.
- Dispose of all fluids according to local regulations and mandates.
- Contact the CZM After Sales Department for tools and supplies suitable to collect and contain fluids on CZM products.

Improper waste disposal can harm the environment.

12.7.2.9.1. Cleaning the DEF Filler Screen*

SMCS Code: 108K-070-Z3

The filler neck adapter filter screen in the diesel exhaust fluid tank will need to be cleaned or replaced if contaminated.

1. Open the Diesel Exhaust Fluid (DEF) compartment.

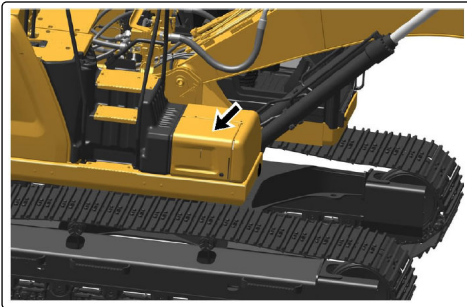

2. Remove fill cap (1).
3. Use a screwdriver or pick to press the tabs on the strainer. Pull the strainer upward from both sides of fill neck adapter (2).

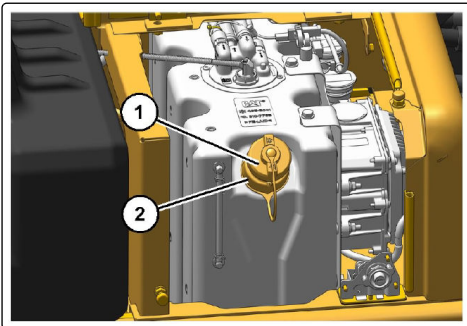

4. Use water or compressed air to clean out the filter screen (3). If there is any debris inside, dry and remove the debris by turning the screen upside down and dumping debris out. If the debris cannot be removed or if the filter screen is damaged, replace the filter screen.

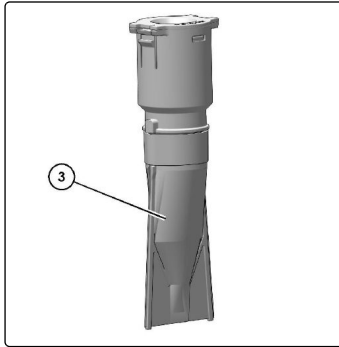

12.7.2.9.2. Replacing the DEF Manifold Filters*

SMCS Code: 108K-510-FI

12.7.2.9.2.1. CAT 323 - CAT 330

Replace the manifold filter (1).

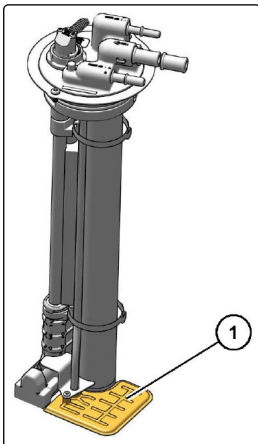

12.7.2.9.3. Draining the DEF*

SMCS Code: 108K-543

ENVIRONMENTAL NOTICE

- Make sure that fluids are contained while performing inspection, maintenance, testing, adjusting, and repairs on the machine.
- Be prepared to collect any fluids with suitable containers before opening any lines or components containing fluids.
- Dispose of all fluids according to local regulations and mandates.
- Contact the CZM After Sales Department for tools and supplies suitable to collect and contain fluids on CZM products.

Improper waste disposal can harm the environment.

1. Prepare the machine for service. For more information refer to [Prepare the Machine for Maintenance*](#) (page 384).

- Remove drain plug (1).

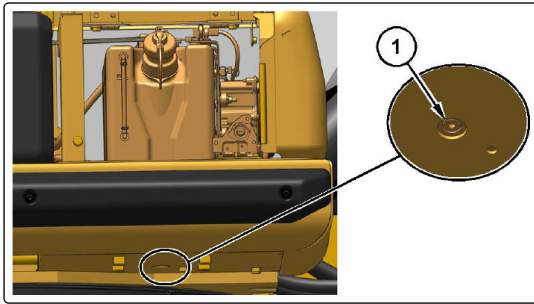

- Drain the diesel exhaust fluid into a suitable container.
- Install and tighten the drain plug to a torque of $20 \pm 3 \text{ N}\cdot\text{m}$ ($177 \pm 26 \text{ lb in}$).

12.7.2.9.4. Filling the DEF*

SMCS Code: 108K-544



IMPORTANT

Stop the engine and turn the engine start switch to the OFF position before filling the DEF tank. Failure to stop the engine may cause fault codes. For more information refer to [Section: "Selective Catalytic Reduction Warning System*" \(page 266\)](#).



ENVIRONMENTAL NOTICE

- Make sure that fluids are contained while performing inspection, maintenance, testing, adjusting, and repairs on the machine.
- Be prepared to collect any fluids with suitable containers before opening any lines or components containing fluids.
- Dispose of all fluids according to local regulations and mandates.
- Contact the CZM After Sales Department for tools and supplies suitable to collect and contain fluids on CZM products.

Improper waste disposal can harm the environment.

See [Section: "Technical Data" \(page 122\)](#) for the capacity of the DEF tank for your machine. The DEF tank is located inside the storage box on the right side of the machine.

Figure 243.

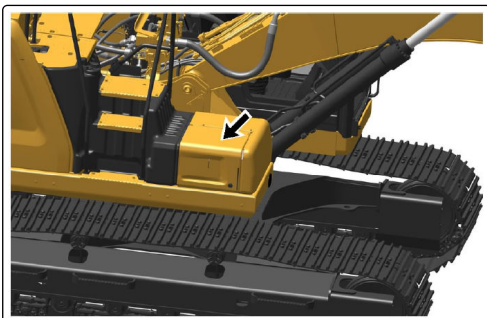

g06183098 DEF Compartment

1. Clean the blue DEF tank filler cap (1) and the surrounding area.

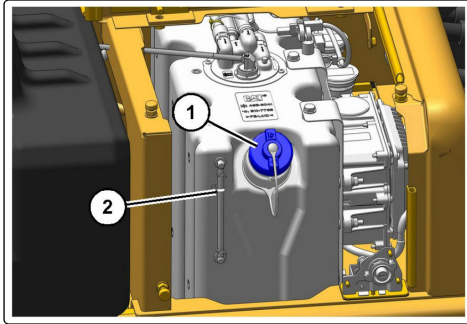

2. Remove the blue DEF tank filler cap (1).



3. Fill the tank with diesel exhaust fluid (DEF). DEF level gauge is located on the front side of DEF tank. Do not fill above the white full mark (2).



IMPORTANT

- Do not fill the DEF tank from a contaminated container or funnel.
- Do not overfill fill the tank. DEF can freeze and needs room for expansion.

4. Install the blue DEF tank filler cap.

Refer to [Section: “Fluids and Lubricants” \(page 400\)](#) for more information on diesel exhaust fluid (DEF) guidelines.

12.7.2.9.5. Replacing the DEF Filter

SMCS Code: 108K-510-F1



IMPORTANT

Ensure that the engine is stopped before any servicing or repair is performed.

12.7.2.9.5.1. CAT 323

PROCEDURE FOR:

- S/N: YCP1–Up
- S/N: HEX1–10000

1. Open the Diesel Exhaust Fluid (DEF) compartment.

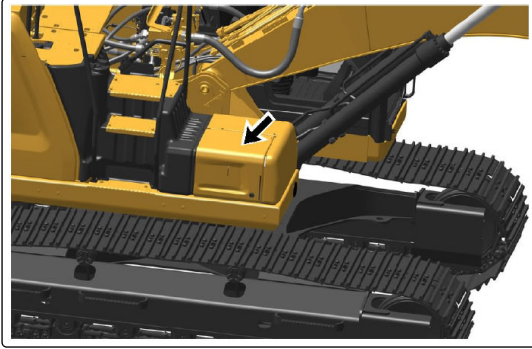

2. Ensure that the area around the DEF filter is clean and free from dirt. For clarity, the DEF assembly has been removed from the compartment.
3. Remove the protective cover (1) from DEF pump housing (2).

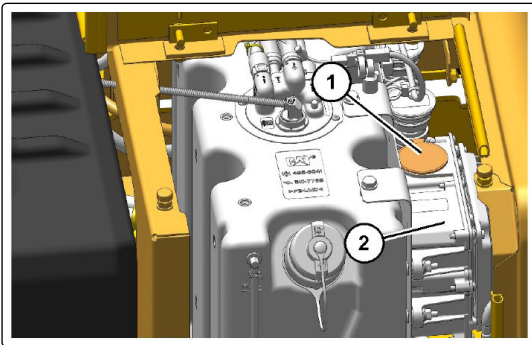

4. Remove the DEF filter assembly (3) and discard.

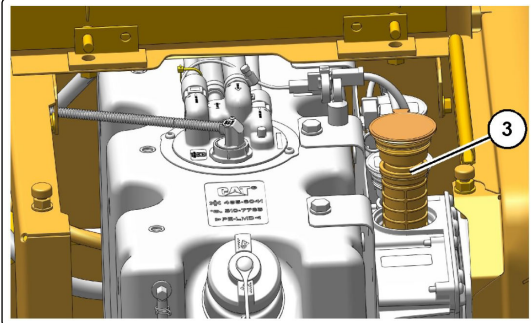

5. Install a new DEF filter assembly into the DEF pump housing.
6. Tighten the filter assembly to 10 N·m (88.5 lb in). Install the protective cover.
7. Turning on the power will automatically prime the DEF system.

PROCEDURE FOR:

- S/N: KFE1–Up
- S/N: MYK1–Up
- S/N: NDL1–Up
- S/N: LTN1–Up
- S/N: HDT1–Up
- S/N: RAZ1–10000

1. Open the Diesel Exhaust Fluid (DEF) compartment.

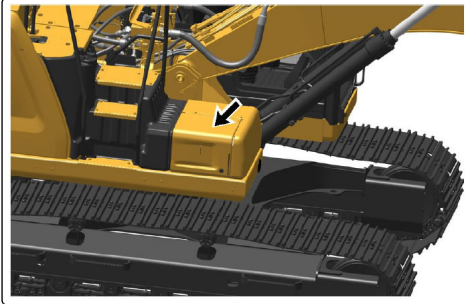

2. Ensure that the area around the DEF filter is clean and free from dirt. For clarity, the DEF assembly has been removed from the compartment.

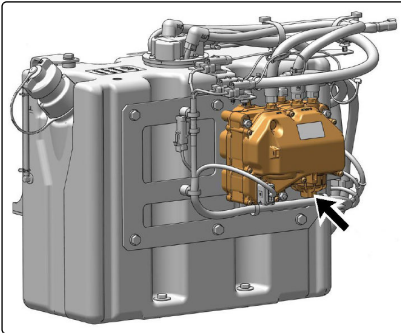

3. Unscrew the cap, and remove the expansion device (1) from DEF filter (2).

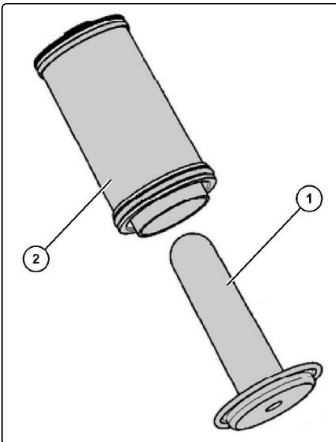

4. Then, remove the DEF filter using the special tool (3) that comes with the new filter. Discard the old filter and expansion device.

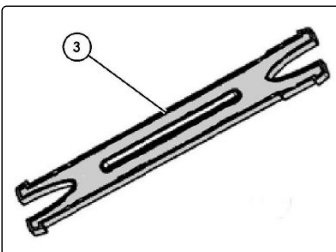

5. Install a new DEF filter assembly into the DEF pump housing.
6. Tighten the filter cap to $20 \pm 5 \text{ N}\cdot\text{m}$ ($15 \pm 4 \text{ lb ft}$).
7. Turning on the power will automatically prime the DEF system.

12.7.2.9.6. Replacing the DEF Injector*

SMCS Code: 108I-510

1. Drain the coolant to remove coolant lines (1). Remove cooling lines (1) and remove Diesel Exhaust Fluid (DEF) line (2).

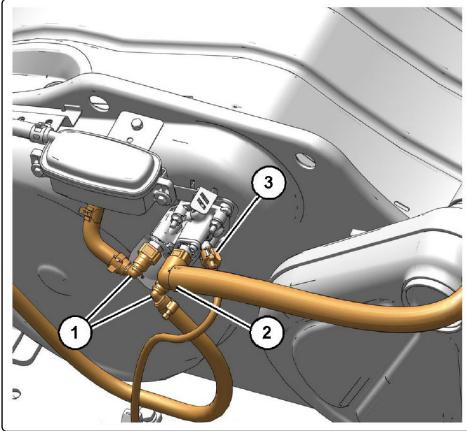

2. Remove electrical connector (3) from DEF injector (5) and install protection caps to DEF injector (5). Remove nuts (4) and washers (9) from DEF injector (5) and remove DEF injector from Clean Emission Module (CEM) (6).

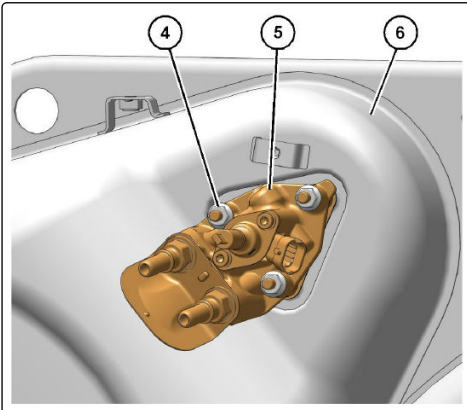

3. Remove gasket (7) and remove studs (8). Discard the gasket and the studs.

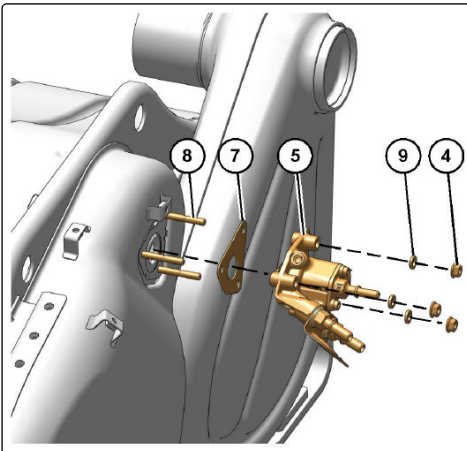

4. Ensure that the sealing face of the CEM is clean and free from dirt.

5. Apply Bostik pure nickel anti-seize compound to the ends of the new studs (8). Install the coated ends of the new studs into the CEM, and tighten to a torque of 5 N•m (44 lb in).
6. Install a new gasket (7), and ensure that the metal side of the gasket is to the CEM. Install new DEF injector (5) to CEM (6).
7. Install washers (9) and apply Bostik pure nickel anti-seize compound to the threads of studs (8).
8. Install nuts (4) and tighten the nuts to a torque of 5 N•m (44 lb in). Retighten the nuts to 5 N•m (44 lb in). Then, turn the nuts an additional 90 degrees.
9. Install electrical connector (3), DEF line (2), and coolant lines (1).
10. Fill the cooling system to the correct level. Ensure that the correct specification of coolant is used.

If available, using the electronic service tool (ET) perform DEF Dosing System Verification test.

12.7.3. Hydraulic System*

12.7.3.1. Releasing of Hydraulic Pressure from the Main Hydraulic System*



WARNING

Personal injury can result from hydraulic oil pressure and hot oil.

- Hydraulic oil pressure can remain in the hydraulic system after the engine has been stopped. Serious injury can be caused if this pressure is not released before any service is done on the hydraulic system.
- Make sure all of the attachments have been lowered, and the oil is cool before removing any components or lines.
- Remove the oil filler cap only when the engine is stopped, and the filler cap is cool enough to touch with your bare hand.



ENVIRONMENTAL NOTICE

- Make sure that fluids are contained while performing inspection, maintenance, testing, adjusting, and repairs on the machine.
- Be prepared to collect any fluids with suitable containers before opening any lines or components containing fluids.
- Dispose of all fluids according to local regulations and mandates.
- Contact the CZM After Sales Department for tools and supplies suitable to collect and contain fluids on CZM products.

Improper waste disposal can harm the environment.

Perform the following steps to release the hydraulic system pressure from the main hydraulic system.



WARNING

For additional safety, wrap the hydraulic joint with material that could absorb/reduce any residual pressure of oil when released.

Loosen the joint slowly, pause, and carefully check the hydraulic joint for tensions indicating the presence of pressure or spring force in lines or components.

1. Park the machine on a level surface.
2. Position the mast in a vertical (operating) position. Lower the rotary to its lowest position on the mast. Lower the work tool or kelly bar to the ground.
3. Release the system pressure from the drilling rig and swing hydraulic circuits.



IMPORTANT

Perform Step 3b through Step 3d immediately after the engine is shut off to ensure adequate pilot system pressure is available to release the pressure in the hydraulic circuits.

- a. Shut off the engine.
- b. Turn the engine start switch to the ON position without starting the engine.
- c. Place the hydraulic activation control lever in the UNLOCKED position.
- d. Move both joysticks in a circular motion to the FULL STROKE positions multiple times until the pilot accumulator has been exhausted.

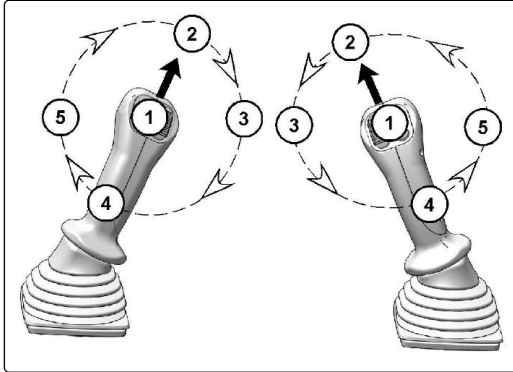
IMPORTANT

Pilot pressure is required to relieve hydraulic system pressure.

- e. Place the hydraulic activation control lever in the LOCKED position.
- f. Start the engine to recharge the pilot accumulator.

IMPORTANT

Do not activate any controls when recharging the pilot accumulator.

- g. Shut off the engine.
- h. Repeat Step 3b through Step 3g until the high pressure lines have been released.
- i. Repeat steps to relieve pressure in the drilling controls.

IMPORTANT

Each time the accumulator is recharged, start the controls at different positions or rotate in the reverse direction.

Doing so will ensure that the same circuit is not being relieved each time.

IMPORTANT

You can also move only the joysticks or pedals of the hydraulic circuit that requires service to the full stroke positions after moving joysticks in a circular motion multiple times.

This action will release the high pressure only in that single hydraulic circuit.

This action will also release any pressure that might be present in the pilot hydraulic circuit.

12.7.3.2. Changing the Hydraulic System Oil*

SMCS Code: 5056-044

WARNING

- Hot oil and hot components can cause personal injury.
- Do not allow hot oil to contact the skin.
- Also, do not allow hot components to contact the skin.



ENVIRONMENTAL NOTICE

- Make sure that fluids are contained while performing inspection, maintenance, testing, adjusting, and repairs on the machine.
- Be prepared to collect any fluids with suitable containers before opening any lines or components containing fluids.
- Dispose of all fluids according to local regulations and mandates.
- Contact the CZM After Sales Department for tools and supplies suitable to collect and contain fluids on CZM products.

Improper waste disposal can harm the environment.

1. Park the machine on a level surface.
2. Position the machine in the transport position, with the rotary high (rotary pulldown cylinder retracted), mast lowered, boom lowered, and undercarriage retracted.

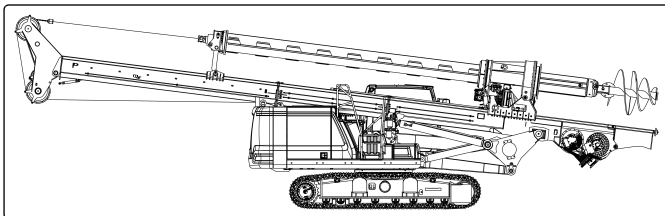

3. Stop the engine.
4. Remove bolts (1) and washers (2).

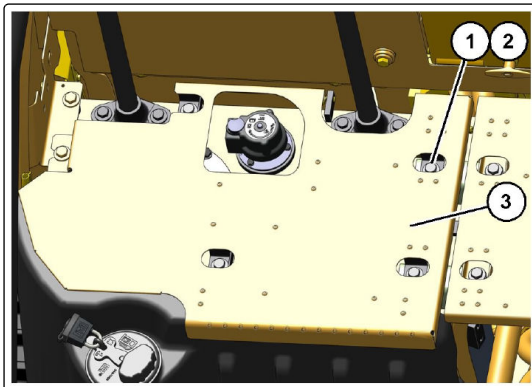

5. Remove cover (3) from the top of the hydraulic tank.
6. Clean the area thoroughly to keep dirt out of the screen cover and filler cap (4).

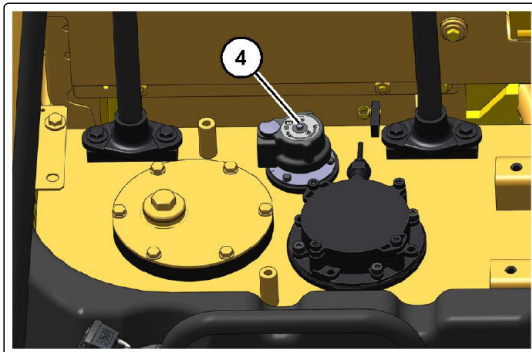

7. Release the pressure that may be present in the return hydraulic circuit with the following procedure. Refer to Illustration for filler cap positions.

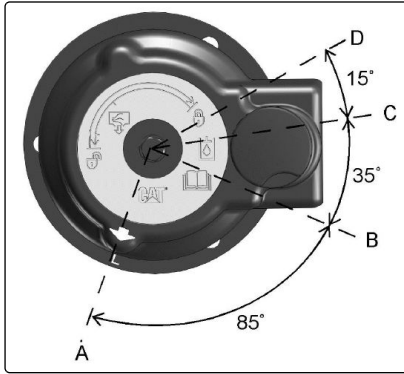

Pos.	Description
A	LOCK position
B	PRESSURE RELEASE - START position
C	PRESSURE RELEASE - END position
D	OPEN position

- a. Turn the filler cap counterclockwise and move the arrow from position (A) to position (B).
 - b. Release the pressure for a minimum of 45 seconds by moving the arrow from position (B) to position (C).
 - c. Move the arrow from position (C) to position (D).
 - d. After the tank pressure is relieved, tighten the filler cap to position (A).
8. Remove the hydraulic tank access cover that is located under the upper structure. Removing the cover will allow access to the drain valve.

Refer to [Containing Fluid Spillage*](#) (page 84) for more information.

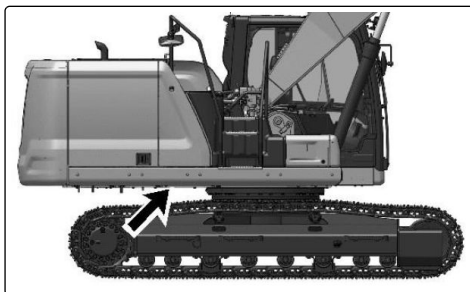

9. Remove plug (5).

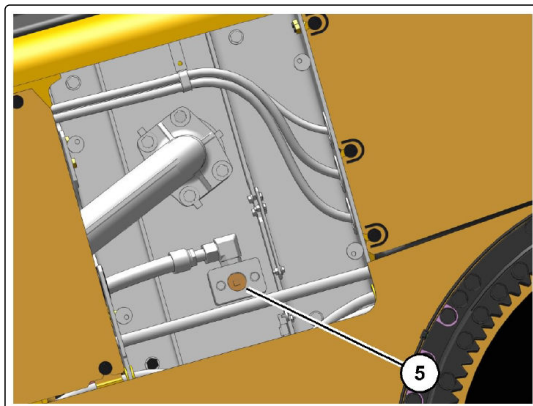

10. Inspect the O-ring. Replace the O-ring if wear or damage is evident.

11. Use a bar to push the plunger up to allow the oil to drain.

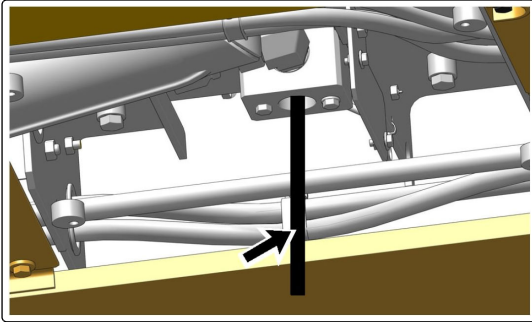

12. Drain the oil into a suitable container.
13. After the oil has been drained, clean drain plug and install. Tighten the plug to 68 ± 7 N·m (50 ± 5 lb ft).
14. Open the access door on the right side of the machine.
15. Clean the pump, the hydraulic lines, and the hydraulic tank.
16. Remove plug (6) from the tube. Allow the oil to drain into a container.

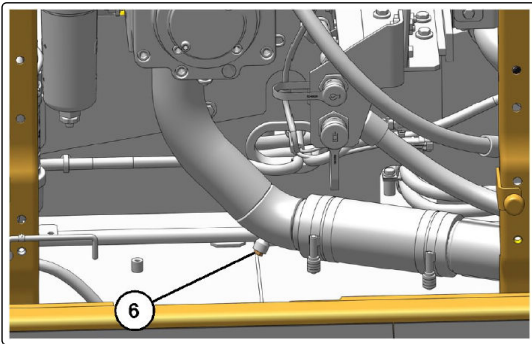

17. Inspect the O-ring. Replace the O-ring if wear or damage is evident.
18. Clean the plug. Install the plug and the O-ring into the drain port.

12.7.3.3. Cleaning the Hydraulic Tank Screen*

1. Remove bolts (7), washers (8), and cover (9).

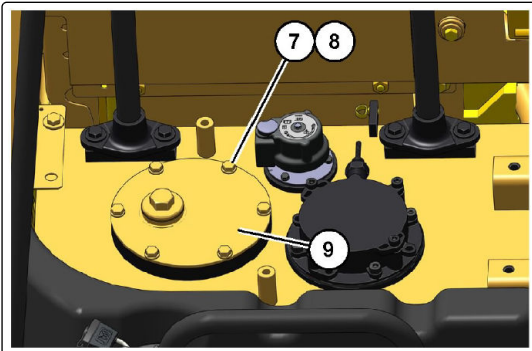

2. Remove spring (10) and screen (11).

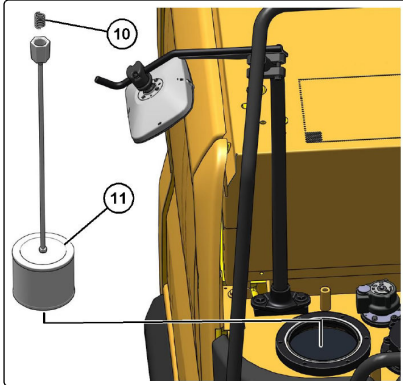

IMPORTANT

Do not allow spring (10) to fall back into the tank.

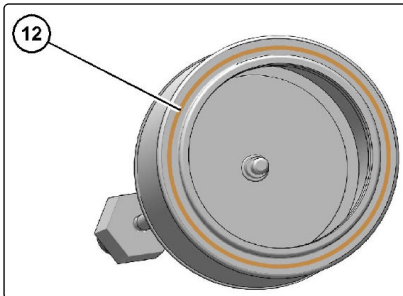
3. Remove O-ring seal (12) from the screen.

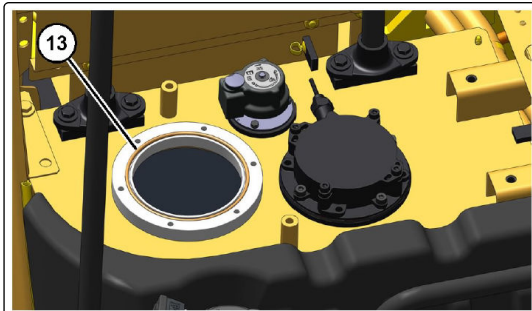

4. Remove O-ring seal (13) from the tank.



5. Inspect O-ring seals (12) and (13). Replace the O-ring seals if wear or damage is evident.
6. Wash the screen in a clean nonflammable solvent. Allow the screen to dry. Inspect the screen. Replace the screen, if the screen is damaged.
7. Install O-ring seal (12) on the screen (11).
8. Install screen (11) and spring (10). Then install cover (9), washers (8), and bolts (7).

IMPORTANT

Make sure that the O-ring seals and the spring are properly positioned during installation.

12.7.3.4. Cleaning the Case Drain Filter*

Figure 244.

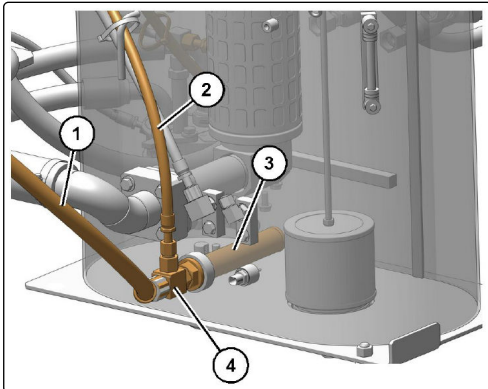

g06220559 Hydraulic System-Drain Filter

1. Remove hose (1) and hose (2) from tee (4). Remove tee (4).
2. Remove case drain filter (3) from the hydraulic tank.
3. Wash the screen of the case drain filter in a clean nonflammable solvent. Allow the filter to dry. Inspect the filter. Replace the filter if the filter is damaged.
4. Inspect the O-ring seal on the filter. Replace the O-ring seal if wear or damage is evident.
5. Install the filter in the hydraulic tank. Tighten the filter to 175 ± 26 N·m (129 ± 19 lb ft).
6. Install the tee onto the filter. Tighten the tee to 65 ± 10 N·m (48 ± 7 lb ft).
7. Install the two hoses onto the tee.

12.7.3.5. Purging Air and Filling the Hydraulic System Oil*

1. Park the machine on a level surface.
2. Position the machine in the transport position, with the rotary high (rotary pulldown cylinder retracted), mast lowered, boom lowered, and undercarriage retracted.

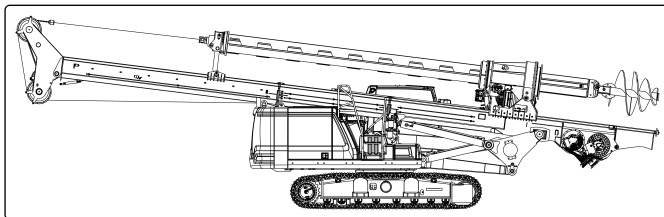

3. Stop the engine.
4. Access the hydraulic pump. The hydraulic pump is located behind the right access door.
5. Remove the hose (14), (15), and connector (16) from the top of the main hydraulic pump.

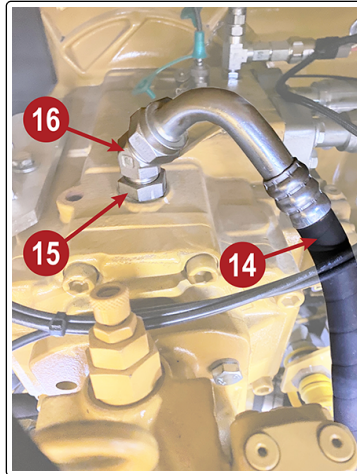
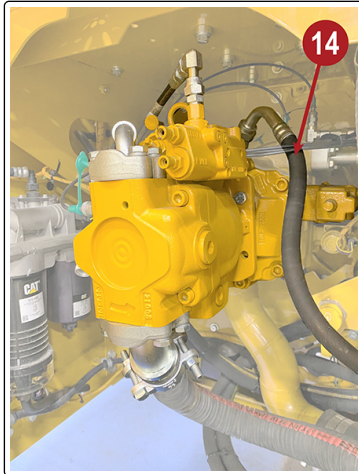

6. Remove the connector (17), and the hose (18) from the auxiliary pump.

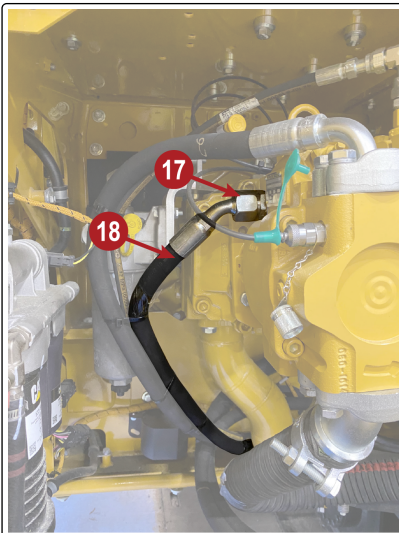

7. Remove the filler cap.
 8. Fill the hydraulic system oil tank up to the top of the oil sight glass, then add an additional of hydraulic oil. (See image, position labeled "Transport").



IMPORTANT

Do not attempt to start the engine until the pump has been filled with hydraulic oil. Serious damage to the hydraulic components can result.

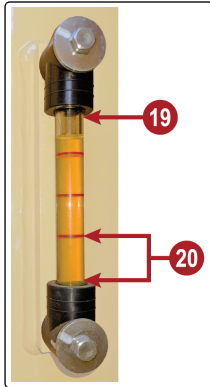

Pos.	Description
19	Transport
20	Operational

9. Inspect the O-ring seal on the filler cap for damage. Replace O-ring, if necessary.
10. Clean the filler cap. Install the filler cap on the hydraulic tank.
11. Add hydraulic oil through the opening of the main hydraulic pump until it is full. Do the same for the auxiliary pump.
12. Check the condition of the seals. If a seal is damaged, replace the seal.
13. After the pumps have been filled with oil, install the drain hoses (14) and (18), connectors (15), (16), and (17), to the original locations.
14. Idle engine for 5 minutes.



WARNING

Pay attention to any unexpected noises coming from the pump, they may indicate cavitation. If noise is heard, shut off the engine immediately and perform the following steps.

- a. Turn off the engine.
- b. Slowly loosen hose (14) and (18) until hydraulic oil flows from the connections. Oil (no bubbles) flowing from the connection indicates that the air has been released from the pump.
- c. Tighten hoses (14) and (18).
- d. Idle the engine for 5 minutes.

15. Raise the mast until it is vertical, place boom at a half stroke, extend the undercarriage, fully lower the rotary, reposition the Kelly bar and remove the work tool as needed.

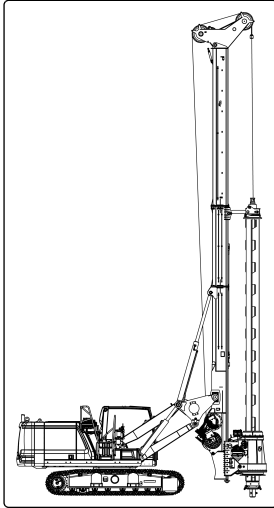

16. Check the hydraulic oil level.

See [Section: "Checking the Hydraulic System Oil Level*" \(page 462\)](#) for more information.

NOTICE

If oil is not seen in the visor, fill the hydraulic tank until oil can be seen in the lower half of the operational range.

17. Close the access door.
18. Close and latch the engine hood.

12.7.3.6. Replacing the Hydraulic System Oil Filter (Return)*

SMCS Code: 5068-510-RJ

WARNING

- Hot oil and hot components can cause personal injury.
- Do not allow hot oil to contact the skin.
- Also, do not allow hot components to contact the skin.

The return filter is a cartridge type filter. The amount of foreign material that enters the hydraulic system is reduced when the filter element is replaced.

IMPORTANT

If the message display shows that the hydraulic return filter is plugged, turn off the machine. After you make sure that the warning has disappeared, start the machine and run the machine on level ground for approximately 10 minutes. If the warning still appears in the message display, inspect the filter and replace the filter, if necessary.

1. Remove bolts (1) and washers (2).

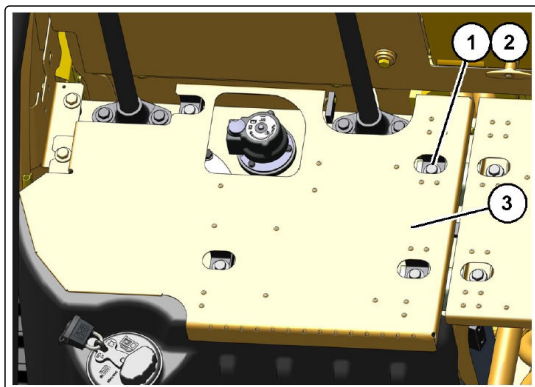

2. Remove cover (3) from the top of the hydraulic tank.
3. Clean the area thoroughly to keep dirt out of the return filter and filler cap.

! WARNING
 Pressurized system!
 The hydraulic tank contains hot oil under pressure.
 To prevent burns from the sudden release of hot oil, relieve the tank pressure with the engine off.
 Relieve pressure by slowly turning the cap until the cap reaches the secondary stop.

4. Release the pressure that may be present in the return hydraulic circuit with the following procedure. Refer to Illustration for filler cap positions.

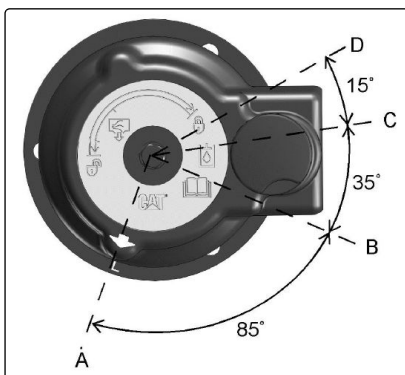

Pos.	Description
A	LOCK position
B	PRESSURE RELEASE - START position
C	PRESSURE RELEASE - END position
D	OPEN position

- a. Turn the filler cap counterclockwise and move the arrow from position (A) to position (B).
- b. Release the pressure for a minimum of 45 seconds by moving the arrow from position (B) to position (C).
- c. Move the arrow from position (C) to position (D).
- d. After the tank pressure is relieved, tighten the filler cap to position (A).
5. Check the hydraulic system oil level. See [Section: "Checking the Hydraulic System Oil Level*" \(page 462\)](#) for more information.
6. Remove bolts (4), disconnect the harness connector from the filter bypass switch, and remove cover assembly (5) from the tank. Inspect the O-ring on the cover for damage and replace it as necessary.

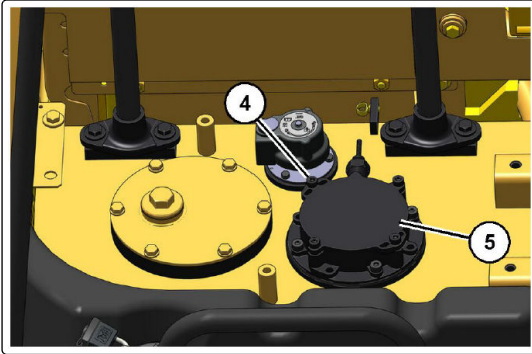

7. Remove filter element (6) and discard. Install a new element into the filter case.

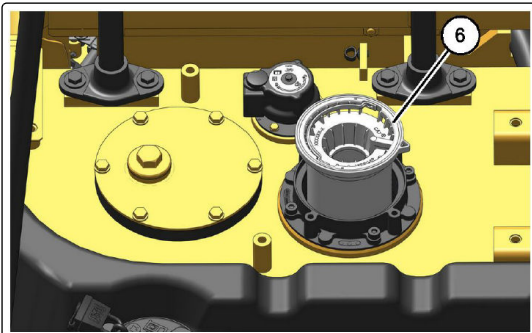

8. Place cover assembly (5) into position in the tank. Install bolts (4) and tighten to 30 ± 7 N·m (22 ± 5 lb-ft). Install the harness connector on the filter bypass switch.

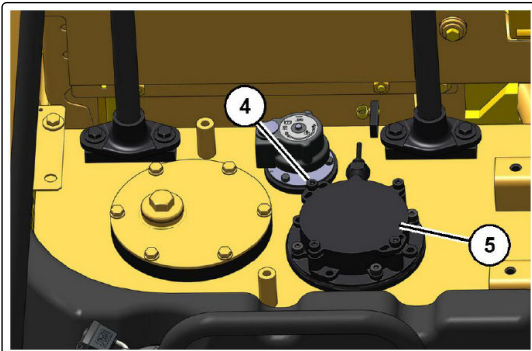

9. Position cover (3) in place on the top of the hydraulic tank. Install bolts (1) and washers (2).

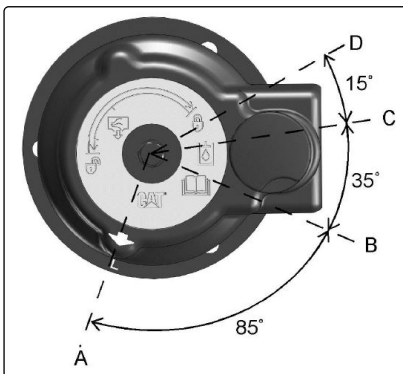

12.7.3.7. Checking the Hydraulic System Oil Level*



WARNING

- Hot oil and hot components can cause personal injury.
- Do not allow hot oil to contact the skin.
- Also, do not allow hot components to contact the skin.



IMPORTANT

Never remove the fill/vent cap from the hydraulic tank if the oil is hot.
Air can enter the system and cause pump damage.

1. Park the machine on a level surface.
2. Position the machine so that the mast is vertical, boom at half-stroke, undercarriage extended, rotary in the lowest position.

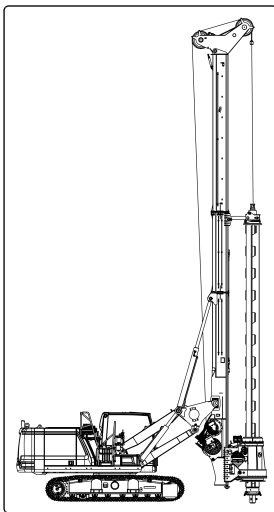

3. Open the access door on the right side of the machine.



4. If the hydraulic oil temperature is between 31°-49° C (87° to 121° F), maintain the oil level in the lower half of the operational range. If the hydraulic oil temperature is between 50°-80° C (122° to 187° F), maintain the oil level within the upper half of the operational range. For temperatures from 10° to 30° C (50° to 86° F) maintain the oil level slightly above the lower limit.

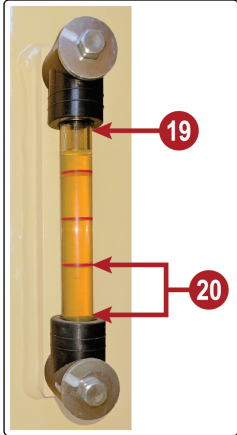

5. Close the access door.
Perform Step 5 through Step 8 if the oil level is low.
Refer to [Containing Fluid Spillage*](#) (page 84) for more information.

6. **WARNING**
 **Pressurized system!**
 The hydraulic tank contains hot oil under pressure.
 To prevent burns from the sudden release of hot oil, relieve the tank pressure with the engine off.
 Relieve pressure by slowly turning the cap until the cap reaches the secondary stop.

Release the pressure that may be present in the return hydraulic circuit with the following procedure. Refer to Illustration for filler cap positions.

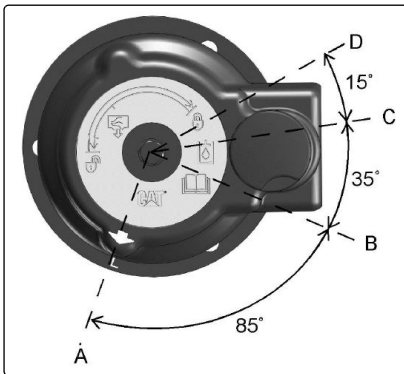

Pos.	Description
A	LOCK position
B	PRESSURE RELEASE - START position
C	PRESSURE RELEASE - END position
D	OPEN position

- a. Turn the filler cap counterclockwise and move the arrow from position (A) to position (B).
 - b. Release the pressure for a minimum of 45 seconds by moving the arrow from position (B) to position (C).
 - c. Move the arrow from position (C) to position (D).
 - d. After the tank pressure is relieved, remove the filler cap.
7. Add oil if necessary.
See [Section: "Fluids and Lubricants"](#) (page 400).

8. Check the O-ring seal on the filler cap. Replace the O-ring seal if the seal is damaged.
9. Clean the filler cap and install it on the tank.
10. Tighten the filler cap on the hydraulic tank to position (A).

12.7.3.8. Obtaining the Hydraulic System Oil Sample*

SMCS Code: 5050-008-OC; 5095-008; 5095-SM; 7542-008; 7542



NOTICE

If some types of hydraulic oils are used, the hydraulic oil change interval is extended to 6000 hours. Some services after 3,000 hours are still strongly recommended. Contact CZM After Sales Department for details.

12.7.3.8.1. CAT 323

The hydraulic oil sampling valve is near the accumulator on the main valve.

1. Remove bolts (1), washers (2), and cover (3).

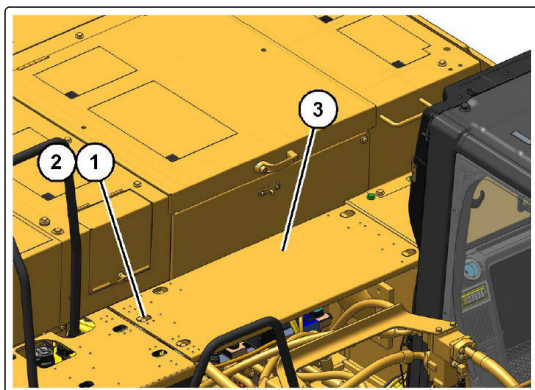

2. Obtain a sample of the hydraulic oil from the hydraulic oil sampling valve that is on the main valve next to the accumulator.

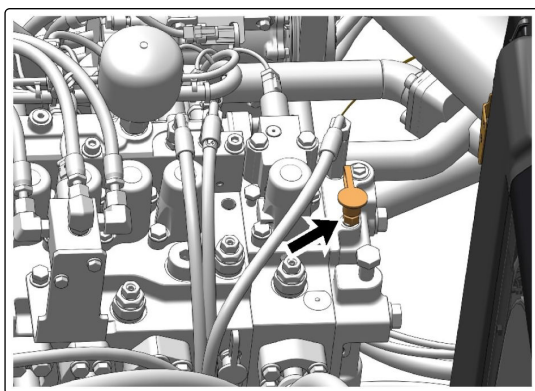

3. Install cover (3), washers (2), and bolts (1).

Contact the CZM After Sales Department for more information about obtaining a sample of the hydraulic oil.

12.7.3.9. Testing Indicators and Gauges*

SMCS Code: 7450-081; 7490-081

Look for broken lenses on the gauges, broken indicator lights, broken switches, and other broken components in the cab.

1. Start the engine.
2. Look for inoperative gauges (if present).
3. Turn on all machine lights. Check for proper operation.
4. Move the machine forward. Release the travel levers and the travel pedals. The machine should stop.
5. Stop the engine.
6. Make any repairs that are required before operating the machine.

12.7.3.10. Inspecting the Oil Filter for Debris*

Figure 245.



g06224663 Hydraulic System-Oil Filter Inspection

The element is shown with debris.

Use a filter cutter to cut the filter element open. Spread apart the pleats and inspect the element for metal and for other debris. An excessive amount of debris in the filter element can indicate a possible failure.

If metals are found in the filter element, a magnet can be used to differentiate between ferrous metals and nonferrous metals.

Ferrous metals can indicate wear from steel parts and on cast iron parts.

Nonferrous metals can indicate wear from the aluminum parts of the engine such as main bearings, rod bearings, or turbocharger bearings.

Small amounts of debris may be found in the filter element. This debris could be caused by friction and by normal wear. Contact CZM After Sales Department to arrange for further analysis if an excessive amount of debris is found.

Using an oil filter element that is not recommended by CZM can result in severe engine damage to engine bearings, to the crankshaft, and to other parts. This can result in larger particles in unfiltered oil. The particles could enter the lubricating system and the particles could cause damage.

12.7.3.11. Cleaning the Radiator, Aftercooler and Oil Cooler Cores*

SMCS Code: 1063-070-KO; 1353-070-KO; 1374-070-KO



WARNING

When pressurized air and/or pressurized water is used for cleaning, wear protective clothing, protective shoes, and eye protection. Eye protection includes goggles or a protective face shield.

The maximum air pressure for cleaning purposes must be reduced to 205 kPa (30 psi) when the nozzle is deadheaded and the nozzle is used with an effective chip deflector and personal protective equipment.

Failure to follow this warning could result in death or serious injury.

1. Open the rear access door on the left side of the machine.

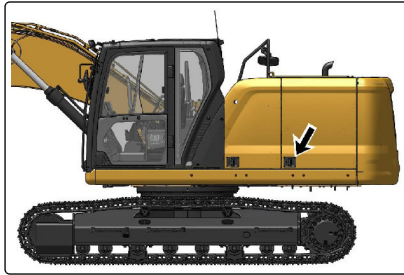

2. Remove dust and debris from all the core fins.
Compressed air is preferred, but high-pressure water or steam can be used to remove dust and general debris from a core.
Contact the CZM After Sales Department for more detailed information about cleaning core fins.

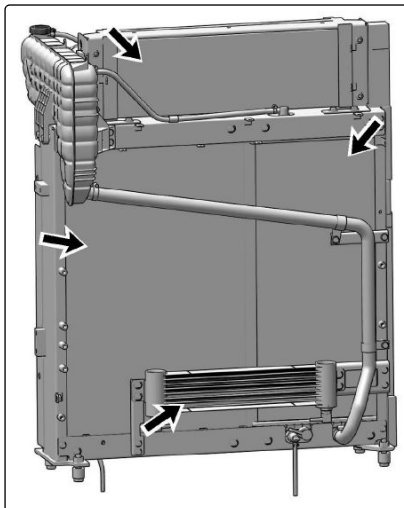

3. Close the access door.

12.7.3.12. Replacing the Receiver Dryer (Refrigerant)*

SMCS Code: 7322-510; 7322-710



WARNING

- Contact with refrigerant can cause frostbite.
- Keep face and hands away to help prevent injury.
- Protective goggles must always be worn when refrigerant lines are opened, even if the gauges indicate the system is empty of refrigerant.
- Always use precaution when a fitting is removed. Slowly loosen the fitting. If the system is still under pressure, release it slowly in a well-ventilated area.
- Personal injury or death can result from inhaling refrigerant through a lit cigarette.
- Inhaling air conditioner refrigerant gas through a lit cigarette or other smoking method or inhaling fumes released from a flame contacting air conditioner refrigerant gas, can cause bodily harm or death.
- Do not smoke when servicing air conditioners or wherever refrigerant gas may be present.
- Use a certified recovery and recycling cart to properly remove the refrigerant from the air conditioning system.

Failure to follow this warning could result in death or serious injury.



IMPORTANT

If the refrigerant system has been open to the outside air (without being plugged) for more than 30 minutes, the receiver-dryer must be replaced.

Moisture will enter an open refrigerant system and cause corrosion which will lead to component failure.

Contact the CZM After Sales Department for the proper procedure to change the receiver-dryer assembly and for the procedure to reclaim the refrigerant gas.

12.7.3.13. Return Line Filter

The drain line filters are screw-on, low-pressure filters for the drilling components.

The filter contains a bypass valve that bypasses oil filtration when the filter becomes blocked.

Figure 246.

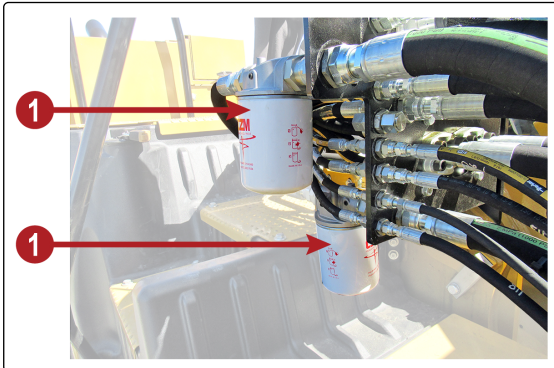

0000327 Return Line Filter

Pos.	Description	Qty
1	Return Filter	2

12.7.3.13.1. Replacing the Return Filter Elements

1. Prepare the machine for service. For more information refer to [Prepare the Machine for Maintenance*](#) (page 384).
2. Clean around the filter to avoid contamination.
3. With the machine off, spin off the filter from its head.
4. Clean the filter base and ensure none of the old gasket material is adhered to.
5. Apply a thin film of lubricating oil to the gasket of the new filter.
6. Thread the new filter on the filter base until the gasket makes contact.
7. Tighten according to the instructions printed on the side of the replacement filter.
8. Start the engine to pressurize the hydraulic system and check for leaks.

12.7.4. Electrical System*

12.7.4.1. Battery*

12.7.4.1.1. Cleaning the Battery*

SMCS Code: 1401-070

Clean the battery surface with a clean cloth. Keep the terminals clean and keep the terminals coated with petroleum jelly. Install the post cover after you coat the terminal post with petroleum jelly.

12.7.4.1.2. Checking the Battery Electrolyte Level*

SMCS Code: 1401-535-FLV; 1401; 1401-535



WARNING

All lead-acid batteries contain sulfuric acid which can burn the skin and clothing. Always wear a face shield and protective clothing when working on or near batteries.



NOTICE

If the machine is operated in extreme temperatures, check the electrolyte level Every 500 Service Hours or 3 months.

When the engine is not run for long periods or when the engine is run for short periods, the batteries may not fully recharge.

Ensure a full charge to help prevent the battery from freezing.

1. Clean the battery surface with a clean cloth. Clean the terminals and the cable clamps. Coat the clamps and the terminals with silicone lubricant or petroleum jelly. Install the post cover.
2. Inspect the electrolyte level in each battery cell. Maintain the electrolyte level to the bottom of the filler openings. Use distilled water. If distilled water is not available, use clean drinking water.

12.7.4.1.3. Inspecting/Replacing the Battery or Battery Cable



WARNING

Personal injury can result from battery fumes or explosions.

Batteries give off flammable fumes that can explode. The electrolyte is an acid and can cause personal injury if it contacts the skin or eyes.

Prevent sparks near the batteries. Sparks could cause vapors to explode.

Do not allow jumper cable ends to contact each other or the engine. Improper jumper cable connections can cause an explosion.

Always wear protective glasses when working with batteries.

1. Turn all the switches to the OFF position. Turn the engine start switch key to the OFF position.
2. Turn the battery disconnect switch to the OFF position. Remove the key.
3. Remove the battery hold-down. **NOTE:** The machine may contain more than one set of batteries.
4. Disconnect the negative battery cable at the battery.
5. Disconnect the positive battery cable at the battery.
6. Disconnect the battery cable at the battery disconnect switch.
7. Inspect the battery terminals for corrosion. Clean the battery terminals and the surfaces of the batteries with a clean cloth.
8. Inspect the battery cables for wear or damage.
9. Make any necessary repairs. If necessary, replace the battery cables and/or the battery.
10. Connect the positive battery cable to the battery.
11. Connect the negative battery cable at the battery.
12. Coat the battery terminals with petroleum jelly to prevent corrosion and install the terminal covers.
13. Reinstall the battery hold-down. Tighten the hold-downs for the battery to prevent the batteries from moving during machine operation.
14. Connect the battery cable at the battery disconnect switch.
15. Install the key and turn the battery disconnect switch ON.

12.7.4.1.4. Tightening the Battery Hold-Down*

SMCS Code: 7257

Tighten the hold-downs for the battery in order to prevent the batteries from moving during machine operation.

12.7.4.1.5. Recycling the Battery

Always recycle a battery. Never discard a battery.

Always return used batteries to one of the following locations:

- A battery supplier.
- An authorized battery collection facility.
- Recycling facility.

12.7.4.2. Camera*

12.7.4.2.1. Cleaning the Camera*



WARNING

Failure to use an appropriate external ladder or an appropriate platform for direct access to the rear view camera could result in slipping and falling which could result in personal injury or death.

Be sure to use an appropriate external ladder or an appropriate platform for direct access to the rear view camera.

The machine's counterweight and the engine hood are not approved as maintenance platforms.



WARNING

Unexpected machine movement can cause injury or death.

In order to avoid possible machine movement, move the hydraulic lockout control to the LOCKED position and attach a "Do Not Operate" or similar warning tag to the hydraulic lockout control.



IMPORTANT

When you access the camera for cleaning, be sure to observe safety procedures for access.

Maintain a three-point contact and/or use a body harness.

The rear view camera is on top of the counterweight.

Figure 247.



g06184579 Camera-Rear View Camera

If necessary, use a damp cloth to clean the glass of the camera. The camera is sealed. The camera is not affected by a wash with a high-pressure spray.

Alternatively, cameras may be cleaned from ground level by using a wash with a high-pressure spray or a damp rag on a wand.

If equipped, clean the right-side view camera.

Figure 248.



g06214504 Camera-Side View Camera

If equipped, clean the left side view camera.

Figure 249.

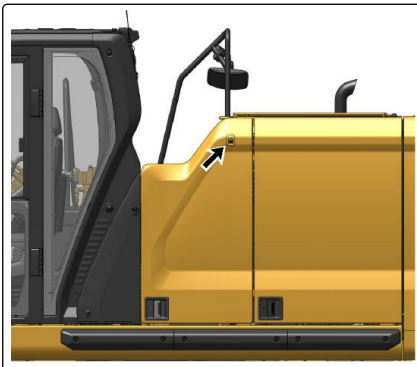

g06263435 Camera-360 Visibility-Left Side

If equipped, clean the front view camera.

Figure 250.

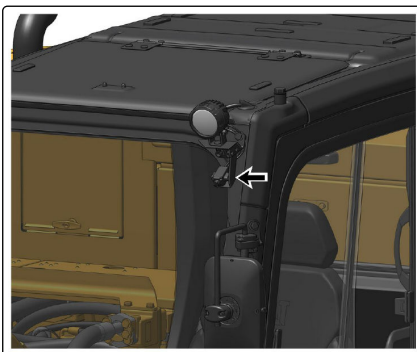

g06263449 Camera-360 Visibility-Front

12.7.4.3. Fuses and Relays*

12.7.4.3.1. Replacing the Fuses*

SMCS Code: 1417-510

The fuse panel is on the left side of the interior storage box. Remove the cover to access the fuses.

Figure 251.

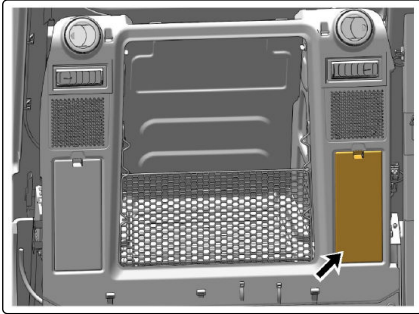

g06181624 Electrical System-Cab Fuses-Cover



Fuses – Fuses protect the electrical system from damage that is caused by overloaded circuits. Change a fuse if the element separates. If the element of a new fuse separates, check the circuit and/or repair the circuit. To replace a fuse, use the puller that is stored in the fuse panel.



IMPORTANT

Always replace fuses with the same type and capacity fuse that was removed. Otherwise, electrical damage could result.



IMPORTANT

If it is necessary to replace fuses frequently, an electrical problem may exist. Contact the CZM After Sales Department support for service.

12.7.4.3.2. Fuses Description*

To replace a fuse, use the puller that is stored in the fuse panel.

The following list identifies the circuits that are protected by each fuse. The amperage for each fuse is included with each circuit.

Figure 252.

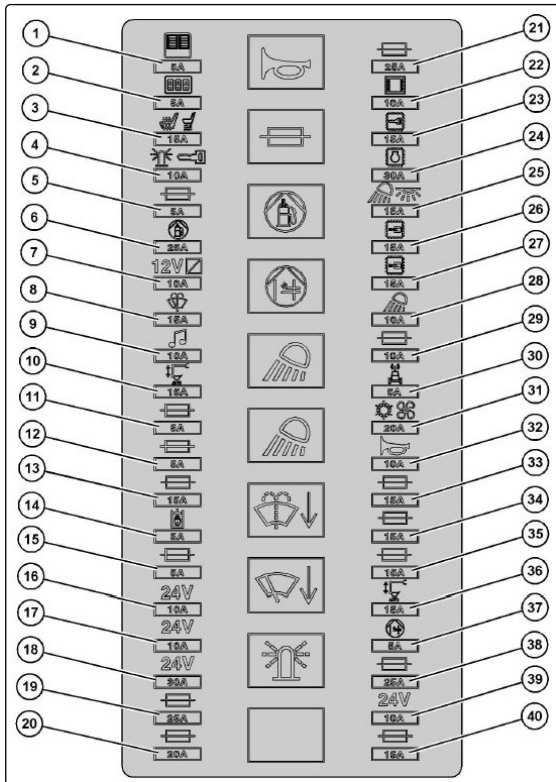

Table 65. Fuses Description

Pos.	Description	Amp.
1	Heater and Air Conditioner Control and Monitor	5
2	Electronic Switch Control Panel	5
3	Grip, Seat Heater, and Air Suspension Seat	15
4	Beacon	10
5	Spare	5
6	Electric Refueling Pump	25
7	12V Converter	10
8	Window Wiper and Window Washer	15
9	Radio	10
10	Cat Grade Control	15
11	Spare	5

Pos.	Description	Amp.
12	Spare	5
13	Spare	15
14	Hydraulic Lock	5
15	Spare	5
16	24V Auxiliary Circuit	10
17	24V Auxiliary Circuit	10
18	24V Auxiliary Circuit	30
19	Spare	20
20	Spare	10
21	Spare	25
22	Display and Electronic Technician Connector	10
23	Body Control Module	15
24	Engine Electronic Control Module	30
25	Dome Light	15
26	Primary Electronic Control Module	15
27	Secondary Electronic Control Module	15
28	Boom Lamp	10
29	Spare	10
30	Product Link Module	5
31	Air Conditioner and Heater Blower	20
32	Horn	10
33	Spare	15
34	Spare	15
35	12V Converter	10
36	Cat Grade Control	15
37	Fuel Lifting Pump	5
38	Spare	25
39	Auxiliary Circuit	10
40	Spare	15

12.7.4.3.3. Relays Description*

Figure 253.

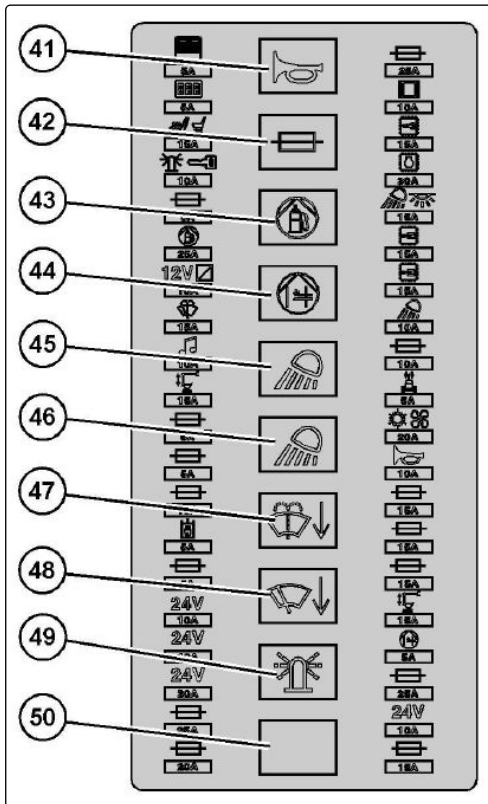

Electrical System-Cab Relays-Description

Table 66. Relays Description

Pos.	Description
41	Horn
42	DEF Pump
43	Grip, Seat Heater, and Air Suspension Seat
44	Beacon
45	Spare
46	Electric Refueling Pump
47	12V Converter
48	Window Wiper and Window Washer
49	Radio
50	Cat Grade Control

12.7.4.3.4. Power Fuse Module*

The power fuse module is located behind the front access door on the left side of the machine.

Remove the cover to access the fuses.

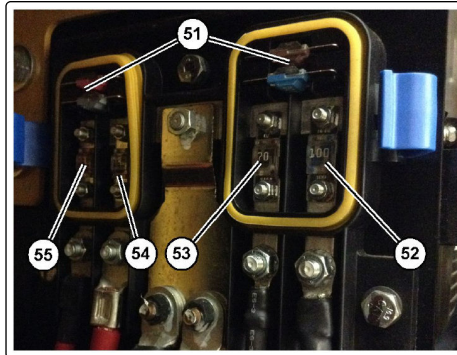
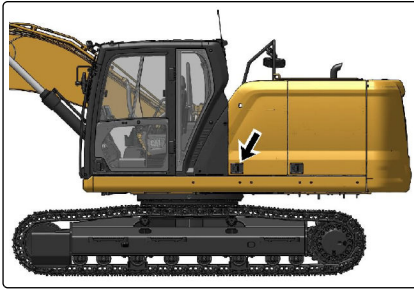

Spare (51) – The fuse module includes spare fuses which can be used if one of the installed fuses opens. One spare fuse is provided for each fuse in use.



Main Circuit 100 Amp (52) – This fuse is designed to protect the wires between the batteries and the fuses. If the wires are shorted to the machine body, this fuse would minimize the damage to the wires.



Glow Plug Circuit 70 Amp (53) – This fuse is designed to protect the glow plugs.



Alternator Circuit 150 Amp (54) – This fuse is designed to protect the alternator. If the batteries are installed with reversed polarity, the fuse would prevent the alternator from damaging the rectifier.



Electric Cooling Fans 125 Amp (55) – This fuse is designed to protect the cooling fans.

12.7.4.3.5. Secondary Power Fuse Module (If Equipped)*

323 machines equipped with Tier 4 engines are equipped with a secondary power fuse module.

The secondary power fuse module is located behind the rear access door on the left side of the machine. Remove the cover to access the fuses.

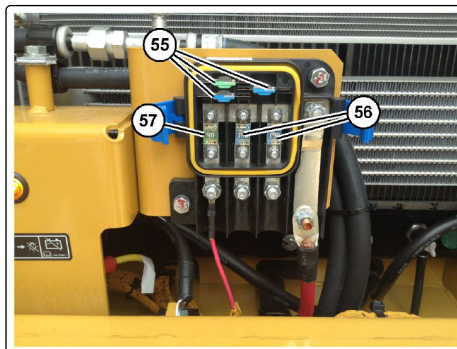

Spare (55) – The fuse module includes spare fuses which can be used if one of the installed fuses opens. One spare fuse is provided for each fuse in use.

Not Used (56) – These fuses are currently not used.



Diesel Exhaust Fluid (DEF) Pump Circuit 40 Amp (57) – This fuse is designed to protect the DEF pump circuit.

12.7.4.4. High Intensity Discharge Lamp (HID)*

12.7.4.4.1. Replacing the High Intensity Discharge Lamp (HID) (If Equipped)*

SMCS Code: 1434-510



WARNING

HID lamps operate at very high voltages.
To avoid electrical shock and personal injury, disconnect power before servicing HID lamps.



WARNING

HID bulbs become very hot during operation.
Before servicing, remove power from the lamp for at least five minutes to ensure the lamp is cool.



ENVIRONMENTAL NOTICE

Although HID bulb materials may change over time, HID bulbs produced at the time of the printing of this manual contain mercury.

When disposing of this component, or any waste that contains mercury, please use caution and comply with any applicable laws.

1. Remove the electrical power from the high intensity discharge lamp (HID). The electrical power must be removed from the HID lamp for at least five minutes, in order to ensure that the bulb is cool.
2. Disassemble the housing for the HID lamp in order to have access to the bulb.



NOTICE

On some HID lamps, the bulb is an integral part of the lens assembly.
The bulb is not removed separately from the lens assembly.
Replace the entire lens assembly on these HID lamps.

3. Remove the bulb from the HID lamp.
4. Install the replacement bulb in the HID lamp.
If the bulb is an integral part of the lens assembly, install the replacement lens assembly in the HID lamp.



IMPORTANT

In order to avoid failure to the bulb that is premature, avoid touching the bulb's surface with your bare hands.

Clean any fingerprints from the bulb with alcohol prior to operation.

5. Reassemble the housing for the HID lamp. Ensure that any printing on the lens is oriented correctly with respect to the HID lamp's mounting position on the machine.
6. Reattach the electrical power to the HID lamp.
7. Check the HID lamp for proper operation.

Contact CZM for additional information on HID lamps.

12.7.4.5. Light Emitting Diode Lamp (LED)*

12.7.4.5.1. Replacing the Light Emitting Diode Lamp (LED)*

SMCS Code: 1434-510

1. Remove the electrical power from the light-emitting diode (LED) lamp.
2. Disassemble the housing for the LED lamp to have access to the bulb.
Note: On some LED lamps, the bulb is a part of the lens assembly. The bulb is not removed separately from the lens assembly. Replace the entire lens assembly on these LED lamps.
3. Remove the bulb from the LED lamp.
4. Install the replacement bulb in the LED lamp. If the bulb is a part of the lens assembly, install the replacement lens assembly in the LED lamp.
5. Reassemble the housing for the LED lamp. Ensure that any printing on the lens is oriented correctly for the LED lamp mounting position on the machine.
6. Reattach the electrical power to the LED lamp.
7. Check the LED lamp for proper operation.

Note: Contact CZM After Sales Department for additional information on LED lamps.

12.7.5. Cab

12.7.5.1. Air Conditioner/Cab Heater Filter (Recirculation)*

SMCS Code: 1054-040-A/C; 1054-510-A/C

The air conditioner filter is on the lower left side of the cab behind the seat.



IMPORTANT

An air recirculation filter element plugged with dust will result in decreased performance and service life to the air conditioner or cab heater.

To prevent decreased performance, clean the filter element, as required.

12.7.5.1.1. Inspecting/Replacing the Air Recirculation Filter Element*

1. Slide the operator's seat forward.
2. Release the cover latch.

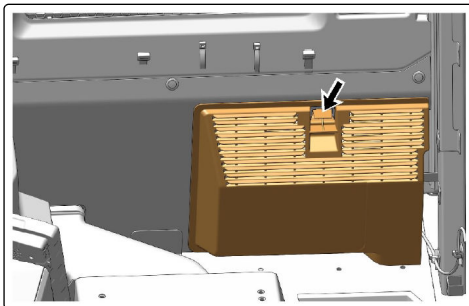

3. Slide the filter element upward.

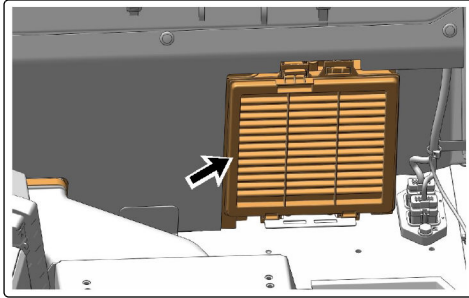

4. Tap the air filter to remove the dirt. Do not use compressed air to clean the filter.
5. After you clean the filter element, inspect the filter element. If the filter element is damaged or badly contaminated, use a new filter element. Make sure that the filter element is dry.
6. Install the filter element.



IMPORTANT

Failure to reinstall the filter element for the air conditioning system will contaminate and damage the system components.

7. Install the cover.

12.7.5.2. Condenser (Refrigerant)*

12.7.5.2.1. Cleaning the Condenser*

SMCS Code: 1805-070



IMPORTANT

If excessively dirty, clean the condenser with a brush. To prevent damage or bending of the fins, do not use a stiff brush.

Repair the fins if found defective.

1. Open the rear access door on the left side of the machine.
The condenser is located in front of the radiator.



2. Inspect the condenser for debris. Clean the condenser, if necessary.

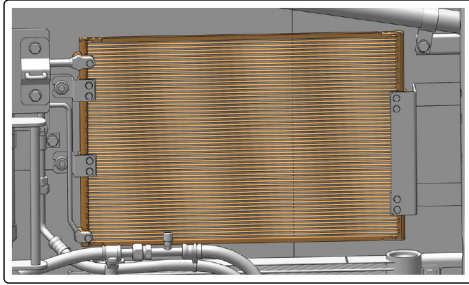

3. Use clean water to wash off all dust and dirt from the condenser.
4. Close the access door.

12.7.5.3. Cab Air Filter (Fresh Air)*

12.7.5.3.1. Cleaning/Replacing the Cab Air Filter*

SMCS Code: 7342-510; 7342-070

The cab air filter is on the left side of the cab.

1. Use the ignition key to open the access panel.
2. Remove the air filter (1).

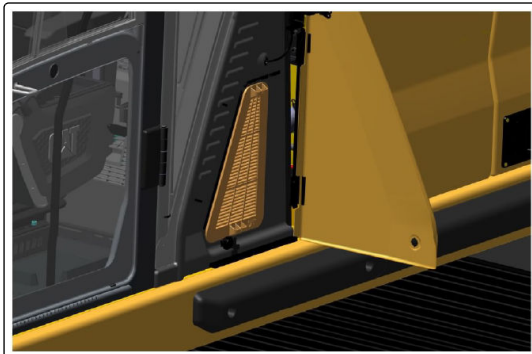

3. Tap the air filter to remove the dirt. Do not use compressed air to clean the filter.
4. After you clean the air filter, inspect the air filter. If the air filter is damaged or badly contaminated, use a new air filter.
5. Install the air filter.
6. Close and lock the access panel.

12.7.5.4. Rollover Protective Structure (ROPS)*

12.7.5.4.1. Inspecting the Rollover Protective Structure (ROPS)*

SMCS Code: 7323-040; 7325-040

Figure 254.



g06184357 Cab-ROPS Bolts

Contact CZM for the repair of any cracks in the ROPS.
 Inspect the ROPS for loose bolts or for damaged bolts.
 Replace any damaged bolts or missing bolts with original equipment parts only.
 Tighten the M24 bolt (1) to 425 ± 50 N·m (315 ± 40 lb ft).



IMPORTANT

Apply oil to all ROPS bolt threads before you install the bolts.
 Failure to apply oil to the bolt threads can result in improper bolt torque.

Do not straighten the ROPS. Do not repair the ROPS by welding reinforcement plates to the ROPS.
 Consult your CZM after-sales support for inspection of any potential damage or repair of any damage to any operator protective structure (including ROPS, FOPS, TOPS, OPS, and OPG).

12.7.5.5. Seat Belt*

12.7.5.5.1. Inspecting the Seat Belt*

SMCS Code: 7327-040

Always inspect the condition of the seat belt and the condition of the seat belt mounting hardware before you operate the machine.
 Replace any parts that are damaged or worn before you operate the machine.

Figure 255.

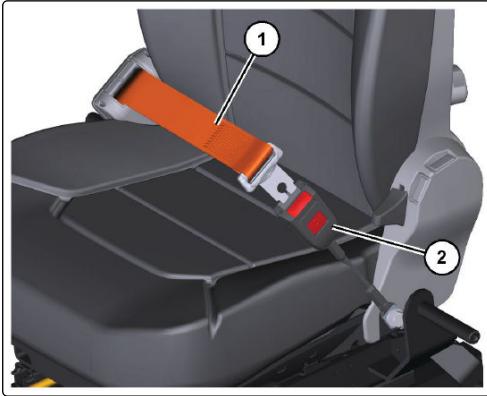

g06224278 Cab-Seat Belt

Inspect buckle (2) for wear or for damage. If the buckle is worn or damaged, replace the seat belt. Inspect seat belt (1) for webbing that is worn or frayed. Replace the seat belt if the webbing is worn or frayed. Inspect all seat belt mounting hardware for wear or for damage. Replace any mounting hardware that is worn or damaged. Make sure that the mounting bolts are tight. If your machine is equipped with a seat belt extension, also perform this inspection procedure for the seat belt extension. Contact CZM for the replacement of the seat belt and the mounting hardware.

! **IMPORTANT**
 The seat belt should be replaced within 3 years of the date of installation. A date of installation label is attached to the seat belt retractor and buckle. If the date of installation label is missing, replace the belt within 3 years from the year of manufacture as indicated on the belt webbing label, buckle housing, or installation tags (non-retractable belts)

12.7.5.5.2. Replacing the Seat Belt*

SMCS Code: 7327-510

The seat belt should be replaced within 3 years of the date of installation. A date of installation label is attached to the seat belt retractor and buckle. If the date of installation label is missing, replace the belt within 3 years from the year of manufacture as indicated on the belt webbing label, buckle housing, or installation tags (non-retractable belts).

Figure 256.

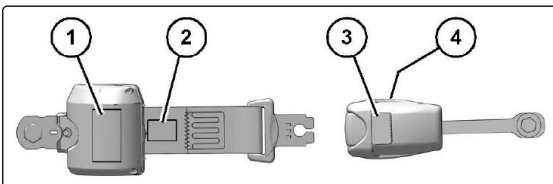

g06183390 Cab-Seat Belt Elements

Pos.	Description
1	Date of installation (retractor)
2	Year of manufacture (tag) (fully extended web)

Pos.	Description
3	Date of installation (buckle)
4	Year of manufacture (underside) (buckle)

Contact the CZM After Sales Department for the replacement of the seat belt and the mounting hardware. Determine the age of a new seat belt before installing on seat. A manufacture label is on the belt webbing and imprinted on the belt buckle. Do not exceed the install by date on the label. A complete seat belt system should be installed with new mounting hardware. Date of installation labels should be marked and affixed to the seat belt retractor and buckle.

i NOTICE
Date of installation labels should be permanently marked by punch (retractable belt) or stamp (nTheon-retractable belt).

If your machine is equipped with a seat belt extension, also perform this replacement procedure for the seat belt extension.

12.7.5.6. Windows*

12.7.5.6.1. Cleaning the Windows*

SMCS Code: 7310-070; 7340-070

Clean the outside of the windows from the ground, unless handholds are available.

Figure 257.



g06224268 Windows-Cleaning

12.7.5.6.1.1. Cleaning Methods*

Aircraft Window Cleaner

Apply the cleaner with a soft cloth. Rub the window with moderate pressure until all the dirt is removed. Allow the cleaner to dry. Wipe off the cleaner with a clean soft cloth.

Soap and Water

Use a clean sponge or a soft cloth. Wash the windows with mild soap or with mild detergent. Also, use plenty of lukewarm water. Rinse the windows thoroughly. Dry the windows with a moist chamois or with a moist cellulose sponge.

Stubborn Dirt and Grease

Wash the windows with a good grade of naphtha, isopropyl alcohol, isopropyl alcohol, or Butyl Cellosolve. Then, wash the windows with soap and with water.

12.7.5.6.1.1.1. Polycarbonate Windows (If Equipped)*

Special care is needed to clean polycarbonate windows.

Wash polycarbonate windows with mild soap and warm water that does not exceed 50° C (122° F).

Use a soft sponge or damp cloth.

Never use a dry cloth or paper towel on polycarbonate windows.

Rinse the windows with a sufficient amount of clean cold water.

NOTICE

Naphtha or kerosene can be used to remove labels, films, paint, or marking pen from polycarbonate windows.

IMPORTANT

- Do not use abrasive, or highly alkaline cleaners.
- Do not use sharp instruments, such as squeegees or razor blades on polycarbonate windows.
- Do not clean polycarbonate windows in the hot sun or at elevated temperatures.

12.7.5.6.2. Inspecting/Replacing the Window Wiper*

SMCS Code: 7305-040; 7305-510

Inspect the condition of the wiper blades.

Replace the wiper blades if the wiper blades are worn or damaged or if streaking occurs.

12.7.5.6.3. Filling the Window Washer Reservoir*

SMCS Code: 7306-544-KE



IMPORTANT

When operating in freezing temperatures, use any commercially available nonfreezing window washer solvent.

1. Open the front access door on the left side of the machine.

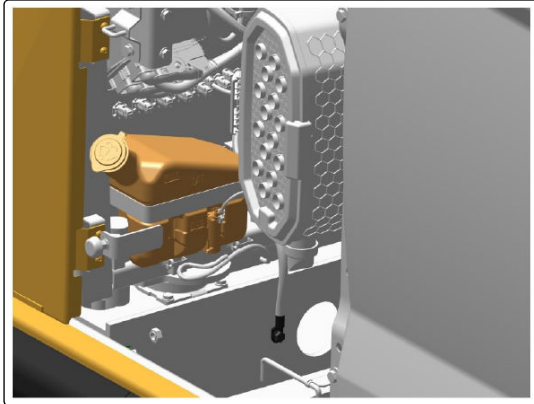

2. Remove the filler cap.



3. Fill the window washer reservoir with washer fluid through the filler opening.
4. Install the filler cap.
5. Close the access door.

12.7.6. Ether Starting Aid Cylinder (If Equipped)*

12.7.6.1. Replacing the Ether Starting Aid Cylinder*

SMCS Code: 1456-510-CD

 **WARNING** Breathing ether vapors or repeated contact of ether with skin can cause personal injury. Personal injury may occur from failure to adhere to the following procedures.

- Use ether only in well-ventilated areas.
- Do not smoke while replacing an ether cylinder.
- Ether is flammable and poisonous. Use ether with care to avoid fires.
- Do not store ether cylinders in living areas or in the operator compartment of a machine.
- Do not store ether cylinders in direct sunlight or temperatures above 49° C (120.2° F).
- Discard cylinders in a safe place. Do not puncture or burn cylinders.
- Keep ether cylinders out of the reach of unauthorized personnel.

The ether cylinder is located inside the rear access door on the left side of the machine. Refer to *Fire and Explosion** (page 87) and *Ether** (page 90) before you replace the ether cylinder.

1. Open the rear access door on the left side of the machine.



2. Loosen the cylinder retaining clamp.

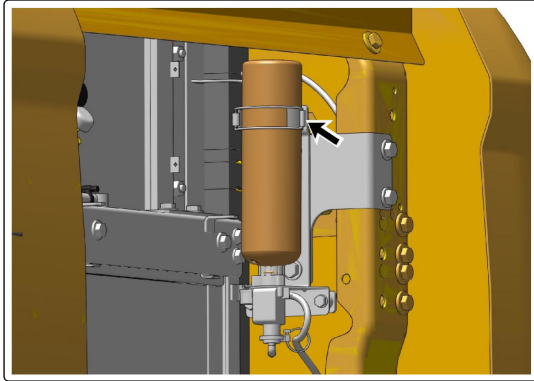

3. Unscrew the empty ether starting aid cylinder and remove the empty ether starting aid cylinder.
4. Remove the used gasket.

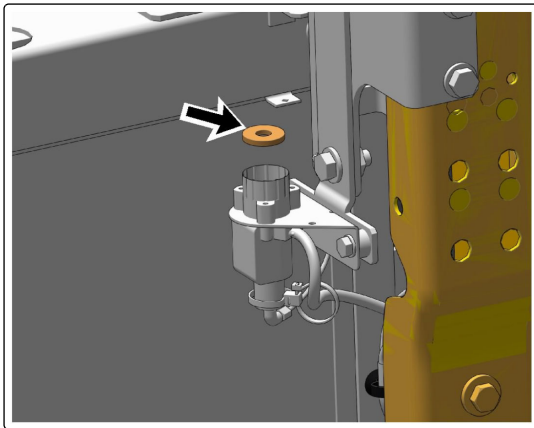

5. Install a new gasket.
 - Note:** new gasket and O-ring is provided with each new ether starting aid cylinder.
6. Install the new ether starting aid cylinder.
7. Tighten the ether starting aid cylinder hand tight.
8. Tighten the cylinder retaining clamp securely.
9. Close the access door.

12.7.7. Decals

12.7.7.1. Cleaning the Decals

- Make sure that all the decals are legible.
- Make sure that the recommended procedures are used to clean the decals.
- Ensure that all the decals are not damaged or missing.
- Clean the decals or replace the decals.

12.7.7.1.1. Hand Washing

Use a wet solution with no abrasive material that contains no solvents and no alcohol.

Use a wet solution with a .pH. value between 3 and 11.

Use a soft brush, a rag, or a sponge to clean the decals.

Avoid wearing down the surface of the decals with unnecessary scrubbing.

Ensure that the surface of the decal is flushed with clean water and allow the decals to air dry.

12.7.7.1.2. Power Washing

Power washing or washing with pressure may be used to clean product identification decals. However, aggressive washing can damage the product identification decals.

Excessive pressure during power washing can damage the product identification decals by forcing water underneath the product identification decals. Water lessens the adhesion of the product identification decal to the product, allowing the product identification decal to lift or curl. These problems are magnified by the wind. These problems are critical for the perforated decal on windows.

To avoid lifting of the edge or other damage to the product identification decals, follow these important instructions:

- Use a spray nozzle with a wide spray pattern.
- Maximum pressure of 83 bar (1200 psi).
- Maximum water temperature of 50° C (120° F).
- Hold the nozzle perpendicular to the decal at a minimum distance of 305 mm (12 inch).
- Do not direct a stream of water at a sharp angle to the edge of the decal.

12.8. FRAME MAINTENANCE



WARNING

Unexpected machine movement can cause injury or death.

In order to avoid possible machine movement, move the hydraulic lockout control to the LOCKED position and attach a “Do Not Operate” or similar warning tag to the hydraulic lockout control.



WARNING

Access to this service point may require climbing on the equipment. Slipping or falling while climbing on the equipment could result in personal injury or death. Refer to *Access to the Drilling Rig (page 100)*.



IMPORTANT

The areas highlighted are of particular importance but other areas must not be neglected. The entire structure must be carefully examined.

Prepare the machine for service. For more information refer to *Prepare the Machine for Maintenance* (page 384)*.

All earthmoving equipment is prone to a high degree of wear. Regular inspections for structural damage are necessary.

The interval between these inspections depends on the factors that follow.

- The age of the machine.
- The severity of the application.
- The loads that have been carried on the machine.
- The amount of routine servicing that has been carried out.

If the machine has been involved in any accident, the machine must be inspected thoroughly. Inspect the machine regardless of the date of the last inspection.

The machine must be cleaned before the machine is inspected.

Proper repair of frames and structures requires specific knowledge of the following subjects.

- Materials that have been used to manufacture the frame members.
- Frame member construction.
- Repair techniques that are recommended by the manufacturer.

Consult CZM After Sales Department if repairs are necessary. We are qualified to carry out repairs on your behalf.

Particular attention should be given to all welded structures. Inspect the following items thoroughly for cracks and defects.

12.8.1. Lower Frame

Checkpoints on the lower frame.

- Check for damaged panels. Specifically, look for any damage to the cab that might invalidate the certification. The cab is a safety device that must be maintained in good condition. Check for loose hardware or missing hardware.
- Check the weld joints in the lower structure.
- Check for loose hardware or missing hardware.

Note: Replace any hardware that is loose, damaged, or missing with original replacement parts only.

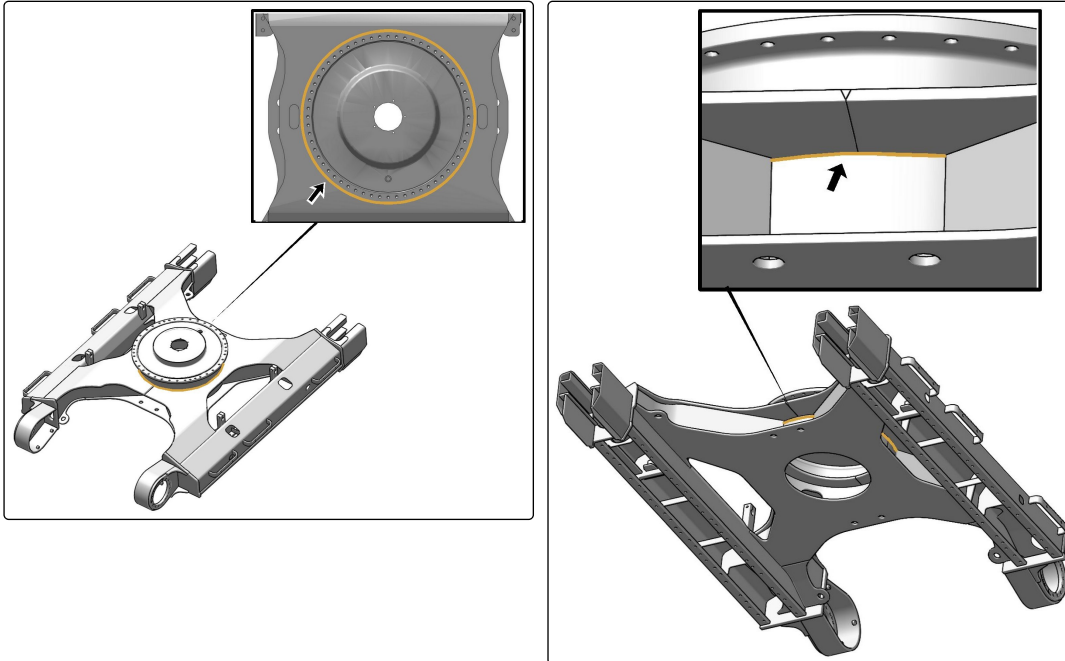

g07552819-g07552823 Lower Frame Checkpoints

12.8.2. Upper Frame

Checkpoints on the upper frame.

Visual inspection on both the left and right sides of the structure.

- Check for damaged panels. Specifically, look for any damage to the cab that might invalidate the certification. The cab is a safety device that must be maintained in good condition. Check for loose hardware or missing hardware.
- Check for loose hardware or missing hardware.

Note: Replace any hardware that is loose, damaged, or missing with original replacement parts only.

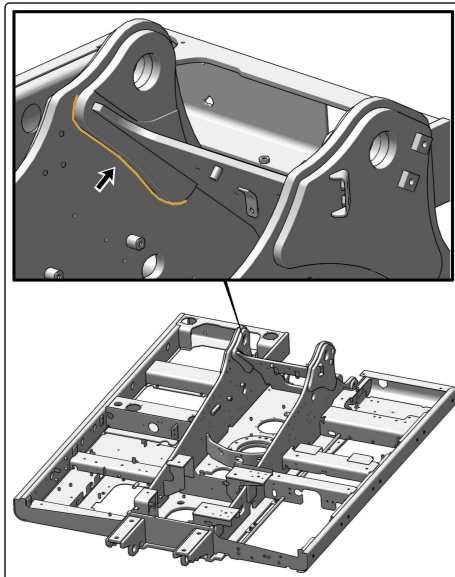
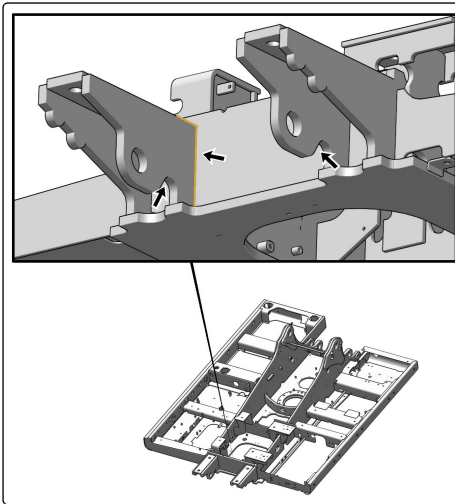
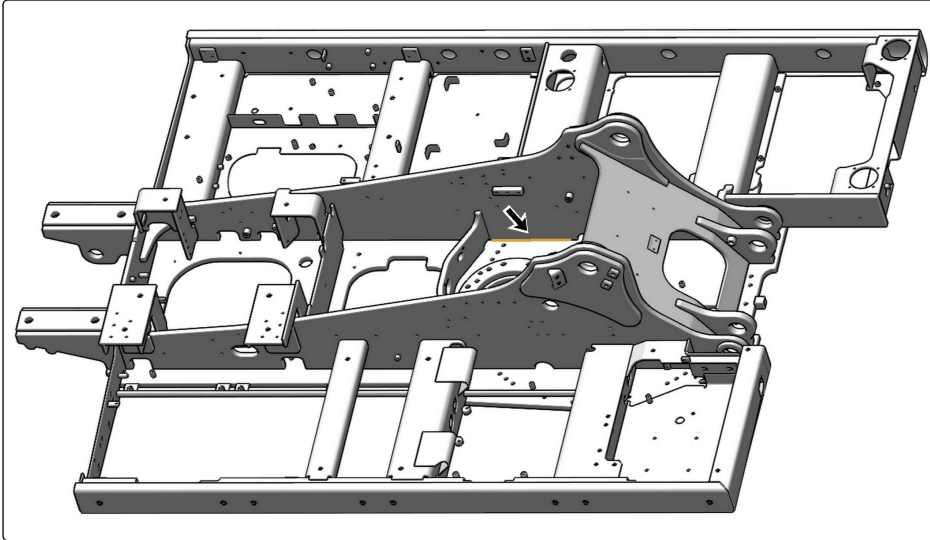

g07552789-g07552796-g07552810 Upper Frame Checkpoints

12.9. SWING MAINTENANCE

12.9.1. Lubricating the Swing Bearing*

SMCS Code: 7063-086



IMPORTANT

- Do not over-grease the swing bearings.
- Do not grease more than the recommended maintenance interval.
- Refer to [Section: "Maintenance Plan" \(page 386\)](#) for more information.
- Refer to [Fluids and Lubricants \(page 400\)](#) for more information.

Contact the CZM After Sales Department if more information on grease is required.

The swing bearing grease zerks are located at the front of the swing drive housing.

Wipe the fittings before you lubricate the swing bearing.

Apply lubricant through the fittings until the lubricant overflows the bearing seals.

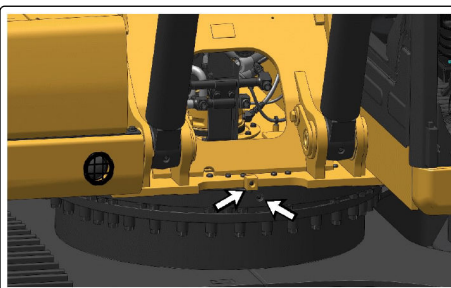
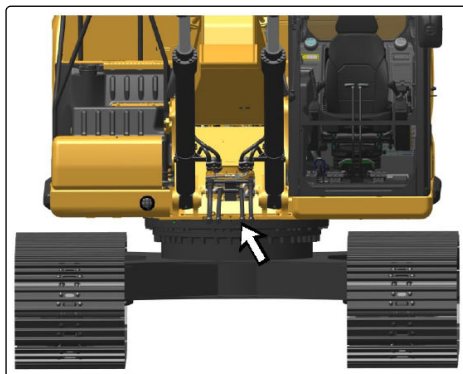

Swing-Bearing Lubrication

12.9.2. Changing the Swing Drive Oil*

SMCS Code: 5459-044



WARNING

- Hot oil and hot components can cause personal injury.
- Do not allow hot oil to contact the skin.
- Also, do not allow hot components to contact the skin.



ENVIRONMENTAL NOTICE

- Make sure that fluids are contained while performing inspection, maintenance, testing, adjusting, and repairs on the machine.
- Be prepared to collect any fluids with suitable containers before opening any lines or components containing fluids.
- Dispose of all fluids according to local regulations and mandates.
- Contact the CZM After Sales Department for tools and supplies suitable to collect and contain fluids on CZM products.

Improper waste disposal can harm the environment.

1. Remove the access cover that is located below the swing drives.

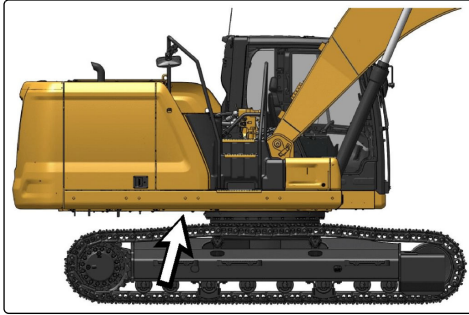

2. Remove drain hose (3) from the holder (1) on the upper frame. Face the end of the hose toward the container. Refer to [Containing Fluid Spillage*](#) (page 84) for more information.

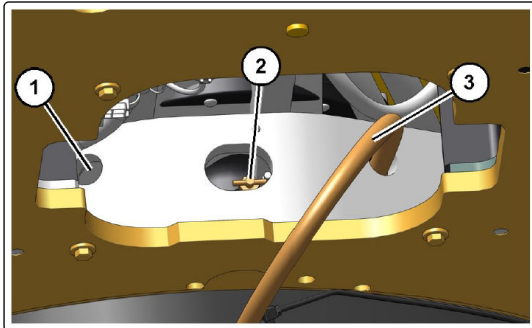

3. Loosen drain valve (2). Drain the oil into a suitable container.
4. Tighten the drain valve. Return the drain hose to the holder (1). Make sure that the end of the hose is facing upward.

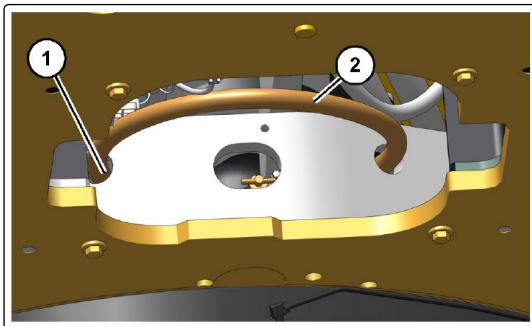

5. Remove dipstick (4).

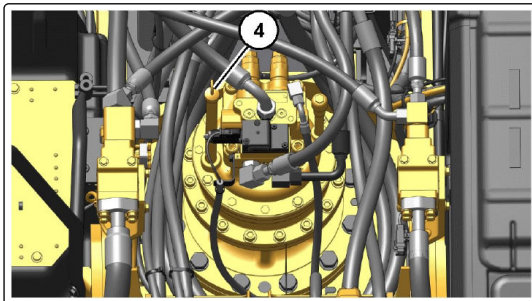

6. Add the specified quantity of oil through the dipstick tube. Refer to [Fluids and Lubricants](#) (page 400) for more information.
7. Maintain the oil level between the “ADD” and “FULL” marks on the dipstick.

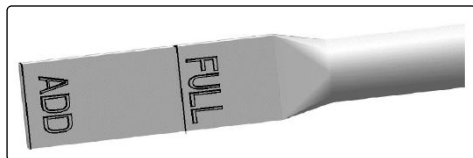

8. Check the drained oil for metal chips or particles. If there are any chips or particles, contact CZM After Sales Department
9. Drained materials should always be disposed of according to local regulations.

12.9.3. Checking the Swing Drive Oil Level*

SMCS Code: 5459-535-FLV

⚠ WARNING

- Hot oil and hot components can cause personal injury.
- Do not allow hot oil to contact the skin.
- Also, do not allow hot components to contact the skin.

The dipstick for the swing drive oil is on the swing drive at the rear base of the boom.

Figure 258.



g06188672 Swing-Oil Dipstick Location

1. Remove the dipstick.
Refer to [Containing Fluid Spillage* \(page 84\)](#) for more information.
2. Check the dipstick. Maintain the oil level between the “ADD” and “FULL” marks on the dipstick. Add oil through the dipstick tube, if necessary. If the oil level is above the “FULL” line, then remove oil from the system. Restore the oil to the correct level position.
Refer to [Fluids and Lubricants \(page 400\)](#) for more information.

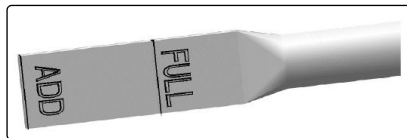

3. Insert the dipstick.

12.9.4. Obtaining the Swing Drive Oil Sample*

SMCS Code: 5459-554-OC; 5459-008; 5459-008-OC; 5459-OC; 7542-008

⚠ WARNING

- Hot oil and hot components can cause personal injury.
- Do not allow hot oil to contact the skin.
- Also, do not allow hot components to contact the skin.

Figure 259.

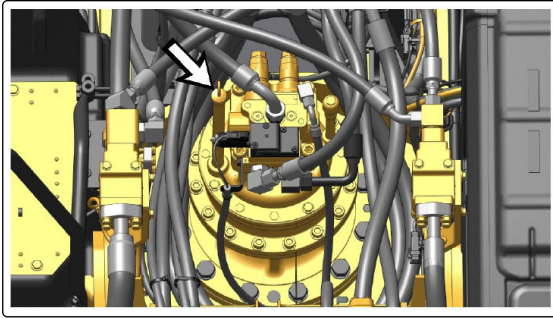

g06188677 Swing-Oil Dipstick

Obtain an oil sample of the swing drive oil through the opening for the dipstick. Contact CZM After Sales Department for information that pertains to obtaining an oil sample from the swing drive housing.

12.9.5. Lubricating the Swing Gear*

SMCS Code: 7063-086



IMPORTANT

Improper lubrication can cause damage to machine components. To avoid damage, make sure that the proper amount of grease is applied to the swing drive. When the amount of grease in the compartment becomes too large, the agitation loss becomes large, thereby accelerating grease deterioration. Grease deterioration can cause damage to the pinion gear of the swing drive and swing internal gear. Not enough grease will result in poor gear lubrication. Refer to *Fluids and Lubricants (page 400)* for more information.

Remove the inspection cover that is located near the mast base. Inspect the grease.

1. Remove bolts (1) and washers (2). Remove cover (3) and gasket (4).

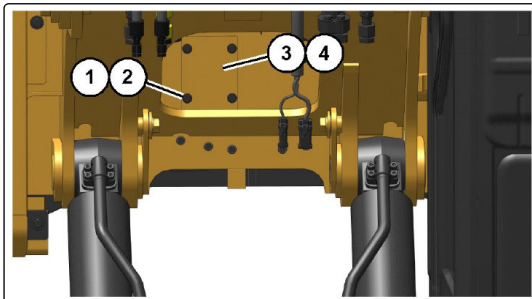

Pos.	Description
1	Bolts
2	Washers
3	Cover
4	Gasket

2. Inspect gasket (4). Replace the gasket if the damage is evident.
3. Check the level of grease. The level of grease is correct when:

- Waves of grease are present from the rotating swing drive pinion.
- The grease is evenly distributed on the floor of the pan.

i NOTICE
Smearred or waveless areas are evidence of a lack of grease.

! IMPORTANT
Add grease, as needed.
Remove grease, as needed.
Too much grease will result in the deterioration of the grease because of excessive movement of the grease.
Too little grease will result in poor lubrication of the swing gear.

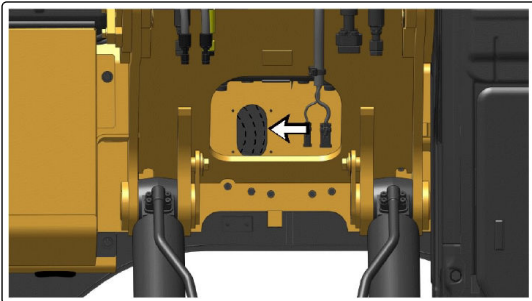

4. Check for contamination and for discolored grease.
5. If the grease is contaminated or discolored with water, change the grease. Remove the covers from below the swing drive underneath the undercarriage frame.

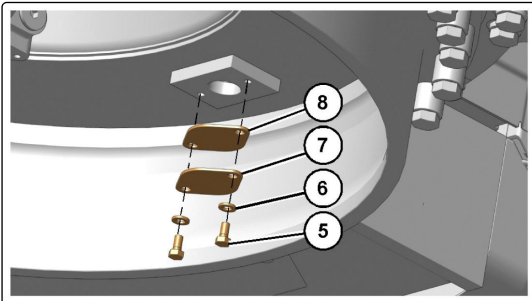

Pos.	Description
5	Bolts
6	Washers
7	Cover
8	Gasket

6. Remove bolts (5), washers (6), cover (7), and gasket (8) to allow the water to drain. When you reinstall cover (7), inspect gasket (8). Replace the gasket if the damage is evident.

7. Raise the boom and turn the upper structure by 1/4 turn. Lower the bucket to the ground.

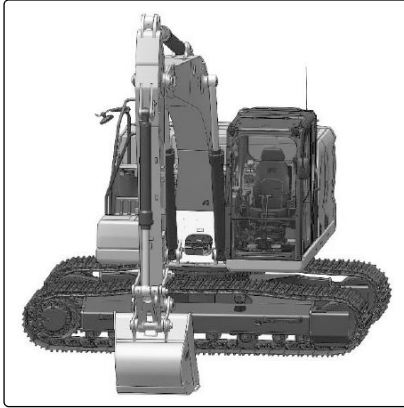

8. Repeat Step 7 at every 1/4 turn in four places. Add grease, as needed.
9. Install gasket (4), cover (3), washers (2), and bolts (1).

12.10. UNDERCARRIAGE MAINTENANCE

12.10.1. Checking the Undercarriage*

SMCS Code: 4150-535

Figure 260.

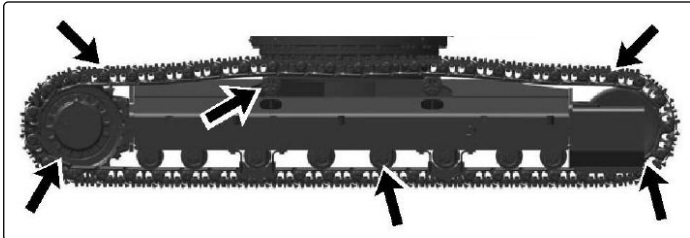

g06182923 Undercarriage-Check Points

1. Check the carrier rollers, the track rollers, and the idler wheels for possible leakage.
2. Check the surface of the track, the carrier rollers, the track rollers, the idler wheels, the track shoes, and the drive sprockets. Look for signs of wear and loose mounting bolts.
3. Listen for any abnormal noises while you are moving slowly in an open area.
4. Check the presence of foreign bodies between tracks and rollers, idler rollers and tracks, sprockets and tracks.
5. If required, clean the undercarriage to keep excess material from building up and solidifying.
6. If abnormal wear exists or abnormal noises or leaks are found, contact CZM.



DANGER

If anomalies are found, immediately resort to routine maintenance, and extraordinary maintenance if necessary.

12.10.2. Cleaning the Undercarriage*

Clean the parts of the undercarriage at the end of the working day.

Encrusted or frozen dirt decreases the life of the undercarriage mechanism and can cause serious damage.

Remove sand and dirt, in particular, from the sliding surfaces of the tensioner group and grease them.

12.10.3. Testing the Travel Alarm*

SMCS Code: 7429-081

Move the machine to test the travel alarm.

1. Start the engine. Move the hydraulic lockout control to the UNLOCKED position.
2. Raise the work tool to avoid any obstacles. Make sure that there is adequate overhead clearance.
3. Use the travel controls to move the machine forward. The travel alarm should sound.
4. Release the travel controls to stop the machine.
5. Use the travel controls to move the machine backward. The travel alarm should sound.
6. Press the alarm mute button. The travel alarm should shut off.



7. Stop the machine. Lower the work tool to the ground. Move the hydraulic lockout control to the LOCKED position. Stop the engine.

12.10.4. Track*

SMCS Code: 4170-025



WARNING

Track adjusting systems use either grease or oil under high pressure to keep the track under tension. Grease or oil under high pressure coming out of the relief valve can penetrate the body causing injury or death.

- Do not watch the relief valve to see if grease or oil is escaping. Watch the track or track adjustment cylinder to see if the track is being loosened.
- During the greasing operation, do not stand in front of the inspection panel.



- Loosen the relief valve for one turn only.
- If the track does not loosen, close the relief valve and contact CZM.
- The pins and bushings in a dry track pin joint can become very hot. It is possible to burn the fingers if there is more than brief contact with these components.



NOTICE

Keeping the track properly adjusted will increase the service life of the track and drive components.

12.10.4.1. Measuring the Track Tension*

1. Operate the machine in the direction of the idlers.
2. Stop with one track pin directly over the front carrier roller. Park the machine and turn off the engine.

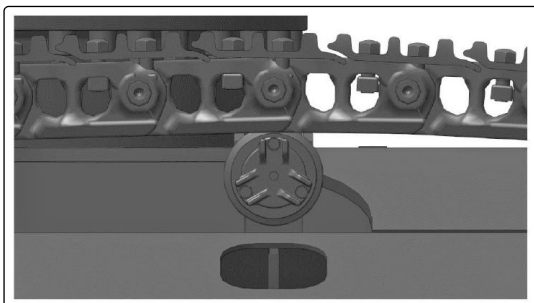

- Place a straight edge on top of the track grousers between the front carrier roller and the idler. The straight edge should be long enough to reach from the front carrier roller to the idler.



NOTICE

If your machine is equipped with three carrier rollers, place a straight edge on the tracks between the carrier rollers.

The straight edge should be long enough to reach from one carrier roller to another carrier roller.



- Measure the maximum amount of sag in the track. The sag is measured from the highest point of the track grouser to the bottom of the straight edge. A track that is properly adjusted will have a sag of 40.0 to 55.0 mm (1.57 to 2.17 inch).
- If the track is too tight, or if the track is too loose, adjust the track tension according to the appropriate procedure below.

12.10.4.2. Adjusting the Track Tension*



WARNING

Track adjusting systems use either grease or oil under high pressure to keep the track under tension. Grease or oil under high pressure coming out of the relief valve can penetrate the body causing injury or death.

- Do not watch the relief valve to see if grease or oil is escaping. Watch the track or track adjustment cylinder to see if the track is being loosened.
- During the greasing operation, do not stand in front of the inspection panel.



- Loosen the relief valve for one turn only.
- If the track does not loosen, close the relief valve and contact CZM.
- The pins and bushings in a dry track pin joint can become very hot. It is possible to burn the fingers if there is more than brief contact with these components.



IMPORTANT

Do not overtighten the tracks. Tracks that are too tight can cause premature failure of the tracks. Tracks that are too tight can cause power loss and bearing failures.

Tracks that are too loose increase the possibility of the track derailing or the drive lugs mis-feeding on the drive sprocket. In aggressive operating conditions, occasional mis-feeding is normal. If consistent mis-feeding is observed, ensure that the track tension is set to the recommended specification. If the track tension is set to the recommended specification and mis-feeding is still observed, then your application may require a tighter track tension. Increase the track tension until consistent mis-feeding is no longer observed.

The intervals for track tension vary depending on the following conditions: the machine application, the operator, the soil conditions, the climate, and the condition of the undercarriage components. Operators are responsible for basic visual inspections of the track tension on a daily basis.



NOTICE

Keeping the track properly adjusted will increase the service life of the track and drive components.

The track adjuster is located on the track frame.

Figure 261.



g06188820 Track Adjuster

12.10.4.2.1. Tooling

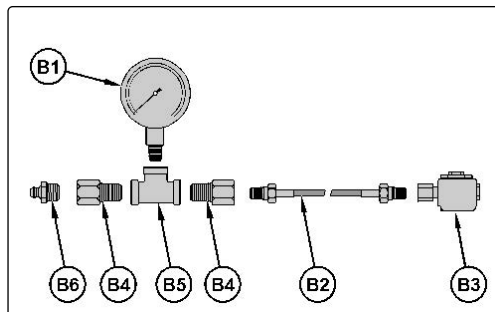
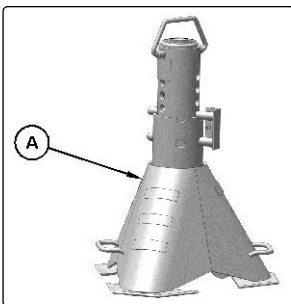

Tooling (A) and Tooling (B)

Table 67. Required Tooling

Tool	Qty	Part Number	Description
A	4	283-1495	Stand Assembly
B	B1	8T-0860	Pressure Gauge
	B2	190-5623	Hose As

Tool	Qty	Part Number	Description
B3	1	4C-7163	Coupling
B4	2	4M-5317	Reducer Bushing
B5	1	006-0210	Pipe Tee
B6	1	3B-8489	Grease Fitting

12.10.4.2.2. Specifications

Table 68. 320 Undercarriage Size (190.5 mm (7.5 in) Pitch)

	Lower Model	Wheel Base	Upper Model	Proper Track Sag	Proper Track Adjuster Pressure
Type 1	TC320VH TC322VH	3830 mm (150.8 in)	323	55 mm (2.17 in)	18000 + 0 - 1000 kPa (2610 + 0 - 145 psi)
Type 2	TC320VH	4120 mm (162.2 in)	323 325 329	65 mm (2.56 in)	20000 + 0 - 1000 kPa (2900 + 0 - 145 psi)
Type 3	TC320VM TC320VH TC323VM TC323VH	4400 mm (173.2 in)	325 329 Custom	70 mm (2.76 in)	21000 + 0 - 1000 kPa (3045 + 0 - 145 psi)

Table 69. 325 Undercarriage Size (203.2 mm (8 in) Pitch)

	Lower Model	Wheel Base	Upper Model	Proper Track Sag	Proper Track Adjuster Pressure
Type 1	TC325VM	4400 mm (173.2 in)	330 336	80 mm (3.15 in)	22000 + 0 - 100 kPa (3190 + 0 - 145 psi)
	TC325VH TC329VM	4600 mm (181.1 in)	336		
Type 2	TC325VH TC329VH	5000 mm (196.9 in)	336 349	85 mm (3.35 in)	22000 + 0 - 100 kPa (3190 + 0 - 145 psi)

Table 70. 330 Undercarriage Size (215.9 mm (8.5 in) Pitch)

	Lower Model	Wheel Base	Upper Model	Proper Track Sag	Proper Track Adjuster Pressure
Type 1	TC330VM TC330VH TC336VM	5000 mm (196.9 in)	330 336 340 345 349 Custom	90 mm (3.54 in)	22000 + 0 - 100 kPa (3190 + 0 - 145 psi)

	Lower Model	Wheel Base	Upper Model	Proper Track Sag	Proper Track Adjuster Pressure
Type 2	TC330VH	5440 mm (214.2 in)	345	95 mm (3.74015 in)	22000 + 0 - 100 kPa (3190 + 0 - 145 psi)
	TC336VH		349		

Table 71. 345 Undercarriage Size (215.9 mm (8.5 in) Pitch)

	Lower Model	Wheel Base	Upper Model	Proper Track Sag	Proper Track Adjuster Pressure
Type 1	TC345VH	5860 mm (230.7 in)	365 374	100 mm (3.9 in)	23000 + 0 - 1000 kPa (3335 + 0 - 145 psi)

Table 72. 365 Undercarriage Size (260.4 mm (10.25 in) Pitch)

	Lower Model	Wheel Base	Upper Model	Proper Track Sag	Proper Track Adjuster Pressure
Type 1	TC365E	6000 mm (236.2 in)	390 Custom	100 mm (3.9 in)	24000 + 0 - 1000 kPa (3480 + 0 - 145 psi)

12.10.4.2.3. Adjustment Procedure

1. Prepare the machine for service. For more information refer to *Prepare the Machine for Maintenance** (page 384).
2. Lift the track frame from the ground and support carbody with tooling (A) or suitable stands or cribbing.

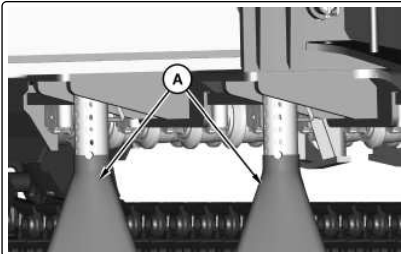

3. Find the center track roller. Measure the clearance between the top of the track chain link and the bottom surface of the track roller where the link rides. Refer to *Specifications* (page 500) for the correct dimension for your undercarriage model.



4. Add grease through injection valve (1) to reduce the clearance between the track roller and track link. Loosen injection valve (1) to increase the clearance between the track roller and track link.

Note: If the machine cannot be raised off the ground to check the clearance between the track roller and the track link, install tooling (B) to injection valve (1) and pressurize the track adjuster to the correct pressure. Refer to *Specifications (page 500)* for the correct pressure value for your undercarriage model.

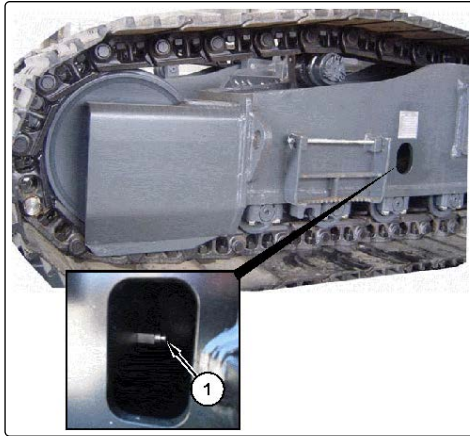

12.10.4.3. Inspecting the Track Adjustment*

SMCS Code: 4170-040

Figure 262.

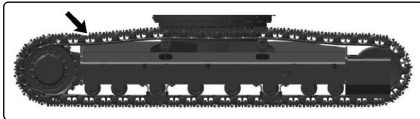

g06182929 Track-Adjustment

Check the track adjustment. Check the track for wear and excessive dirt buildup. If the track appears to be too tight or too loose, refer to *Section: "Adjusting the Track Tension*" (page 498)*.

12.10.5. Final Drive*

12.10.5.1. Changing the Final Drive Oil*

SMCS Code: 4050-044-FLV

WARNING

- Hot oil and hot components can cause personal injury.
- Do not allow hot oil to contact the skin.
- Also, do not allow hot components to contact the skin.

Figure 263.

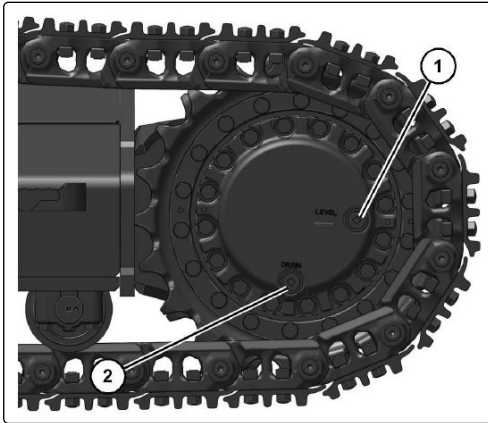

g06182944 Final Drive-Drain and Level Plugs

1. Position one final drive so that oil drain plug (2) is at the bottom.
Refer to [Containing Fluid Spillage*](#) (page 84) for more information.
2. Remove drain plug (2) and level plug (1). Allow the oil to drain into a suitable container.
3. Clean the plugs and inspect the O-ring seals. If wear or damage is evident, replace the drain plug, the level plug, and/or the O-ring seals.
4. Install drain plug (2).
5. Fill the final drive to the bottom of the opening on level plug (1).
See [Section: "Fluids and Lubricants"](#) (page 400).

**NOTICE**

If the oil fills slowly, the fill hole may be blocked by the planetary gear.
Rotate the final drive to move the planetary gear away from the fill hole.

**IMPORTANT**

Overfilling the final drive will cause the seals on the travel motor to allow hydraulic oil or water to enter the final drive.
The final drive may become contaminated.

6. Install level plug (1).
7. Perform Step 1 to Step 6 on the other final drive. Use a different container for the oil so that the oil samples from the final drives will be separate.
8. Completely remove the oil that has spilled onto surfaces.
9. Start the machine and allow the final drives to run through several cycles.
10. Stop the machine. Check the oil level.
11. Check the drained oil for metal chips or particles. If there are any chips or particles, contact CZM After Sales Department

ENVIRONMENTAL NOTICE

- Make sure that fluids are contained while performing inspection, maintenance, testing, adjusting, and repairs on the machine.
- Be prepared to collect any fluids with suitable containers before opening any lines or components containing fluids.
- Dispose of all fluids according to local regulations and mandates.
- Contact the CZM After Sales Department for tools and supplies suitable to collect and contain fluids on CZM products.

Improper waste disposal can harm the environment.

12.10.5.2. Checking the Final Drive Oil Level*

SMCS Code: 4050-535-FLV

WARNING

- Hot oil and hot components can cause personal injury.
- Do not allow hot oil to contact the skin.
- Also, do not allow hot components to contact the skin.

Figure 264.

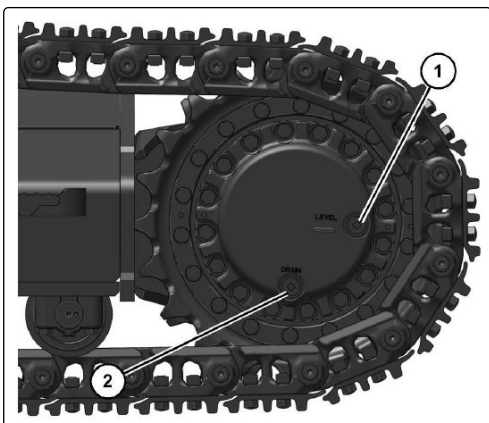

g06182944 Final Drive-Drain and Level Plugs

1. Position one final drive so that oil drain plug (2) is at the bottom.
Refer to [Containing Fluid Spillage*](#) (page 84) for more information.
2. Remove oil level plug (1).
3. Check the oil level. The oil should be near the bottom of the level plug opening.
4. Add oil through the level plug opening, if necessary.
See [Section: "Fluids and Lubricants"](#) (page 400).

NOTICE

If the oil fills slowly, the fill hole may be blocked by the planetary gear.
Rotate the final drive to move the planetary gear away from the fill hole.

IMPORTANT

Overfilling the final drive will cause the seals on the travel motor to allow hydraulic oil or water to enter the final drive.
The final drive may become contaminated.

5. Clean oil level plug (1). Inspect the O-ring seal. Replace the O-ring seal if the O-ring seal is worn or damaged.
6. Install oil level plug (1).
7. Repeat the procedure for the other final drive.

12.10.5.3. Obtaining the Final Drive Oil Sample*

SMCS Code: 4011-008; 4050-SM; 4050-008; 7542-008



WARNING

- Hot oil and hot components can cause personal injury.
- Do not allow hot oil to contact the skin.
- Also, do not allow hot components to contact the skin.

Figure 265.

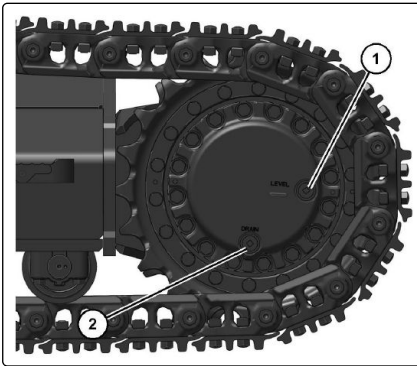

g06182944 Final Drive-Drain and Level Plugs

1. Position one final drive so that oil drain plug (2) is at the bottom.
Refer to [Containing Fluid Spillage*](#) (page 84) for more information.
2. Remove oil level plug (1).
3. Obtain a sample of the final drive oil through the hole for the oil level plug.
4. Install oil level plug (1).

Contact CZM for more information on obtaining a sample of the final drive oil.

12.11. WIRE ROPES MAINTENANCE

12.11.1. Inspecting the Wire Rope

Wire rope is a consumable component with a limited lifespan. As wire rope ages, it will have some structural damage caused by abrasion and corrosion. The lifespan of the wire rope will vary depending on operating conditions. Wire rope should be replaced whenever damage is found.

Inspect all of the wire rope, but provide extra attention to:

- Attachment points.
- Rope sections that pass through sheaves repeatedly.
- Sections exposed to conditions that may accelerate wear.

Wire rope must be replaced if:

- More than 10 percent of the wires within one strand of the wire rope (except for filling steel wire) are open. Filler wires are not considered load-bearing.
- Broken wires at the wire rope ends at connecting points. Wire rope may be cut and new rope end fittings attached.
- An abnormal increase in the number of broken wires over a short period.
- The rope has distortions such as slack windings, bends, flattening, reduced thickness in spots, protruding strands, or other visible deformations.
- Heavily corroded sections.
- Reduced rope elasticity or increased elongation.

Try to determine if any wire rope defects are caused by a mechanical failure that must be corrected before installing a new wire rope.

12.11.2. Lubricating the Wire Rope

If the wire rope is dirty or has layers of hardened lubricant, it must be cleaned prior to lubrication.

Use a wire rope lubricating oil and grease compatible with the existing lubricants on the wire rope.

It is recommended to lubricate the wire rope with a penetrating rope lubricant followed by a surface-protecting grease. Make sure to remove excess grease from the surface to minimize dirt sticking to the grease.

12.11.3. Replacing the Winch Wire Rope

1. Place the mast in the horizontal position.
2. Unwind to provide some slack in the cable.
3. Disconnect the wire rope from its live end anchor.
4. Unwind the old wire rope from the winch drum. You will need to enable the override switch to bypass the winch safety limit switch.
5. Disconnect the wire rope at the winch drum by removing the lock plate.

NOTE: Main winch drum shown, auxiliary winch drum is similar but has the lock plate on the outside of the drum.

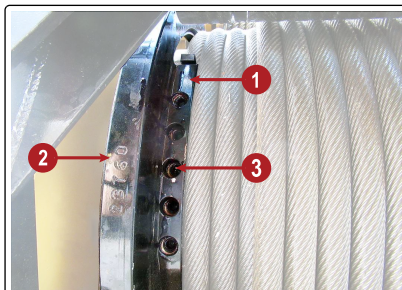

Pos.	Description
1	Wire Rope Lock Plate
2	Main Winch Drum
3	Cap Screw (Qty 5)

6. Secure the new wire rope onto the drum and secure it with the lock plate and fasteners.
7. Wind the wire rope onto the drum while applying tension. See [Section: “Applying Wire Rope Tension” \(page 507\)](#) for more information.

IMPORTANT

- Keep the wire rope clean, do not allow the wire rope to contact the ground.
- Do not wind the rope over sharp edges to prevent damage to the wire rope and/or machine.

8. Enable the winch safety switch and connect the wire rope live end to its anchor point.

WARNING

Failure to properly anchor the wire rope end can cause the wire rope to pull out and drop the load resulting in death, serious injury, or damage to the machine.

12.11.3.1. Applying Wire Rope Tension

WARNING

Make sure the new wire rope is pulled directly from the carrier reel.
Do not pull the rope off the carrier reel from the side, this will twist the rope and cause distortions when under tension.
Failure to follow this warning could result in death or serious injury.

To properly wind the new wire rope on the winch, the wire rope must be under tension.

If the lower winding layers are too loose, the upper winding layers can press between the lower strands under load resulting in damage to the wire rope.

Things to consider when tensioning the wire rope during installation:

- Tension the wire rope when winding with at least 2 percent of the wire rope's maximum load rating.
- Do not apply tension to a wire rope by squeezing it. For example, squeezing the wire rope between two planks. The wire rope may become permanently deformed.
- Apply tension to the carrier reel holding the new rope, not directly to the rope itself.

12.11.3.2. After the Installation of a New Rope

After the wire rope has been installed, before being used, make a few small load cycles.

The new wire rope should be extended and retracted to seat it properly and allow it to conform to the winch drum.

12.12. MAIN WINCH MAINTENANCE



NOTICE

The reducer gear oil also lubricates the brake.

There is no need to change the brake oil, it is changed when the reducer oil is replaced.

12.12.1. Checking the Main Winch Reducer/Brake Oil Level

1. Place the mast in the vertical operating position (leveled).
2. Position the rotary all the way to the bottom of the mast.
3. Lower the work tool to the ground.
4. Make sure there is no suspended load.
5. Wait 2 minutes for the oil to settle before checking the level.
6. Prepare the machine for service. For more information refer to *Prepare the Machine for Maintenance** (page 384).
7. Remove the level plug (1), there may be a sight glass instead of a plug. If there is a sight glass, do not attempt to remove it.
8. The oil level should be at the bottom of the hole or mid-level on the sight glass (if present).
9. Add oil as required.

See *Adding the Main Winch Reducer/Brake Oil* (page 509) and install the plug.

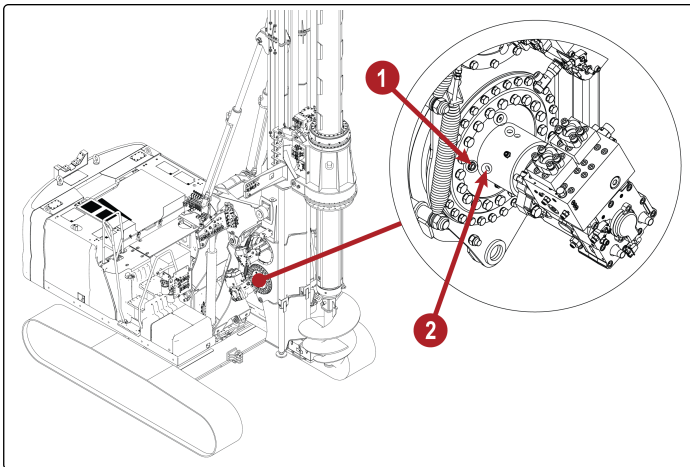

12.12.2. Adding the Main Winch Reducer/Brake Oil

1. Place the mast in the vertical operating position (leveled).
2. Position the rotary all the way to the bottom of the mast.
3. Lower the work tool to the ground.
4. Make sure there is no suspended load.
5. Prepare the machine for service. For more information refer to *Prepare the Machine for Maintenance** (page 384).
6. Remove the level plug (1), there may be a sight glass instead of a plug. There is no need to remove the brake level plug (2).
7. Remove the reducer breather port plug (3) and brake breather port plug (4).
8. Add new oil through the reducer breather port (3) which will also fill the brake section.
Refer to *Fluids and Lubricants* (page 400) for more information.
9. Wait 1 minute for the oil to drain down and recheck the oil level.
10. Add more oil as required until the oil level is at the mid-level on the sight glass or bottom of the check/fill hole.
11. Make sure all removed plugs are installed and tightened.

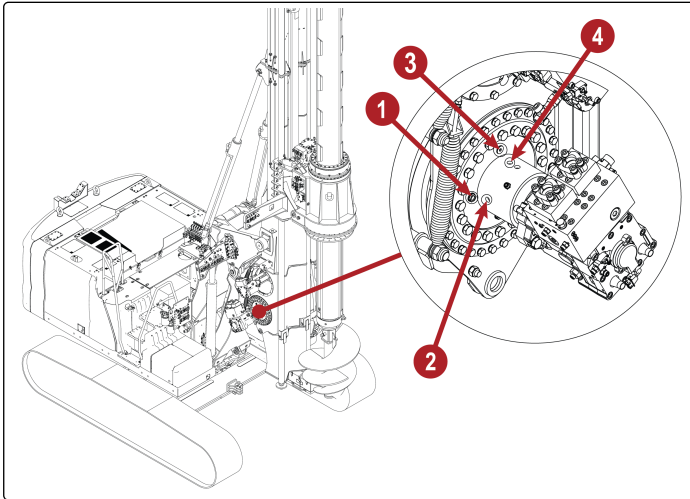

12.12.3. Draining and Refilling the Main Winch Reducer/Brake Oil



ENVIRONMENTAL NOTICE

- Make sure that fluids are contained while performing inspection, maintenance, testing, adjusting, and repairs on the machine.
- Be prepared to collect any fluids with suitable containers before opening any lines or components containing fluids.
- Dispose of all fluids according to local regulations and mandates.
- Contact the CZM After Sales Department for tools and supplies suitable to collect and contain fluids on CZM products.

Improper waste disposal can harm the environment.

1. Operate the winch for about 5 minutes to warm up the oil.
2. Place the mast in the vertical operating position (leveled).
3. Position the rotary all the way to the bottom of the mast.
4. Lower the work tool to the ground.
5. Make sure there is no suspended load.
6. Prepare the machine for service. For more information refer to *Prepare the Machine for Maintenance** (page 384).
7. Remove the breather plug (3).
8. Remove the reducer drain plug (5) and brake drain plug (6) to drain the old oil from the reducer and the brake at the same time.



IMPORTANT

Drain the oil while the oil is warm for more efficient draining.
Use caution with any adaptors to avoid any leaks.

9. Clean the plugs and inspect the seals, if damaged, replace the plug or seal.
10. Check the drained oil for metal chips or particles. If there are any chips or particles, contact CZM After Sales Department
11. Install and tighten all removed plugs.
12. Remove the brake breather plug (4), then add the new oil through the reducer breather hole (3) which will fill both the reducer and the brake.
Refer to *Fluids and Lubricants (page 400)* for more information.
13. Wait 1 minute for the oil to drain down, check the oil level at the sight glass or plug hole, and add more oil if needed.
14. Make sure all removed plugs are installed and tightened.

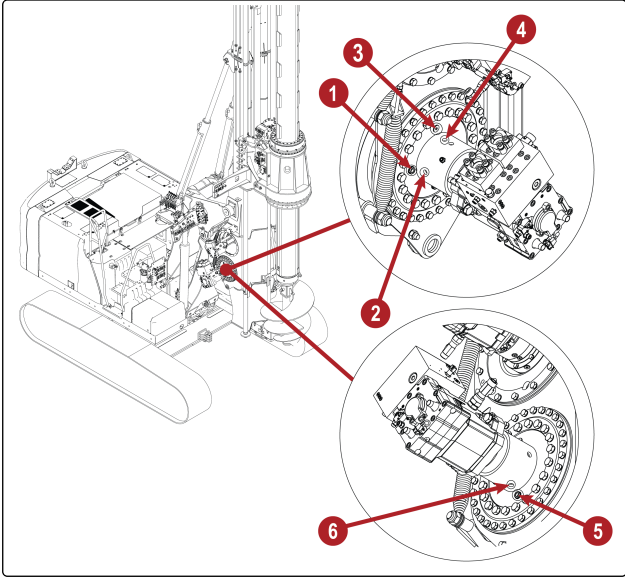

12.13. AUXILIARY WINCH MAINTENANCE



ENVIRONMENTAL NOTICE

- Make sure that fluids are contained while performing inspection, maintenance, testing, adjusting, and repairs on the machine.
- Be prepared to collect any fluids with suitable containers before opening any lines or components containing fluids.
- Dispose of all fluids according to local regulations and mandates.
- Contact the CZM After Sales Department for tools and supplies suitable to collect and contain fluids on CZM products.

Improper waste disposal can harm the environment.

12.13.1. Checking the Auxiliary Winch Reducer/Brake Oil Level

1. Place the mast in the vertical operating position (leveled).
2. Position the rotary all the way to the bottom of the mast.
3. Lower the work tool to the ground.
4. Make sure there is no suspended load.
5. Wait 2 minutes for the oil to settle before checking the level.
6. Prepare the machine for service. For more information refer to *Prepare the Machine for Maintenance** (page 384).
7. Remove the level plug (1), there may be a sight glass instead of a plug. If there is a sight glass, do not attempt to remove it.
8. The oil level should be at the bottom of the hole or mid-level on the sight glass (if present).
9. Add oil as required.

See *Section: "Adding the Auxiliary Winch Reducer/Brake Oil"* (page 513) for more information.

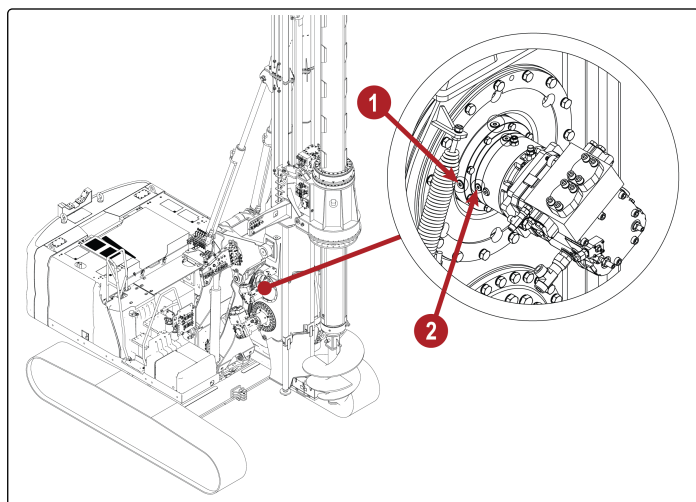

12.13.2. Adding the Auxiliary Winch Reducer/Brake Oil

1. Place the mast in the vertical operating position (leveled).
2. Position the rotary all the way to the bottom of the mast.
3. Lower the work tool to the ground.
4. Make sure there is no suspended load.
5. Prepare the machine for service. For more information refer to *Prepare the Machine for Maintenance** (page 384).
6. Remove the level plug (1), there may be a sight glass instead of a plug. There is no need to remove the brake level plug (2).
7. Remove the reducer breather port plug (3) and brake breather port plug (4).
8. Add new oil through the reducer breather port (3) which will also fill the brake section.
Refer to *Fluids and Lubricants* (page 400) for more information.
9. Wait 1 minute for the oil to drain down and recheck the oil level.
10. Add more oil as required until the oil level is at the mid-level on the sight glass or bottom of the check/fill hole.
11. Make sure all removed plugs are installed and tightened.

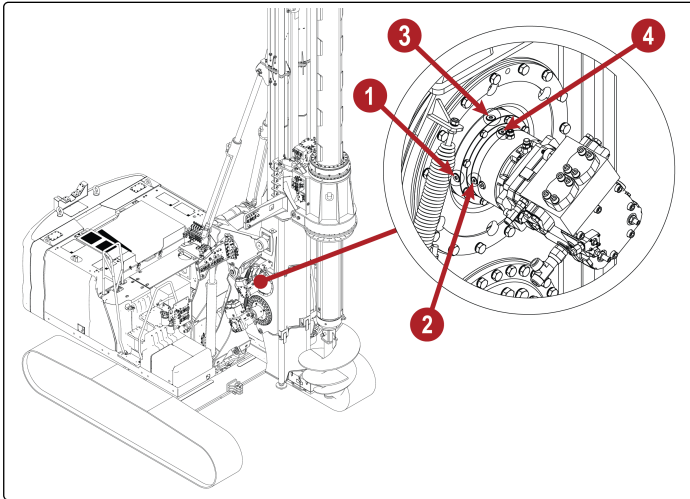

12.13.3. Draining and Refilling the Auxiliary Winch Reducer/Brake Oil



ENVIRONMENTAL NOTICE

- Make sure that fluids are contained while performing inspection, maintenance, testing, adjusting, and repairs on the machine.
- Be prepared to collect any fluids with suitable containers before opening any lines or components containing fluids.
- Dispose of all fluids according to local regulations and mandates.
- Contact the CZM After Sales Department for tools and supplies suitable to collect and contain fluids on CZM products.

Improper waste disposal can harm the environment.

1. Operate the winch for about 5 minutes to warm up the oil.
2. Place the mast in the vertical operating position (leveled).
3. Position the rotary all the way to the bottom of the mast.
4. Lower the work tool to the ground.
5. Make sure there is no suspended load.
6. Wait 2 minutes for the oil to settle before checking the level.
7. Prepare the machine for service. For more information refer to *Prepare the Machine for Maintenance** (page 384).
8. Remove the breather plug (3).
9. Remove the reducer drain plug (5) and brake drain plug (6) to drain the old oil from the reducer and the brake at the same time.



IMPORTANT

Drain the oil while the oil is warm for more efficient draining.
Use caution with any adaptors to avoid any leaks.

10. Clean the plugs and inspect the seals, if damaged, replace the plug or seal.
11. Check the drained oil for metal chips or particles. If there are any chips or particles, contact CZM After Sales Department
12. Install both reducer and brake drain plugs.
13. Remove the brake breather plug (4), then add the new oil through the reducer breather hole (3) which will fill both the reducer and the brake.
14. Wait 1 minute for the oil to drain down, check the oil level at the sight glass or plug hole, and add more oil if needed.
15. Make sure all removed plugs are installed and tightened.

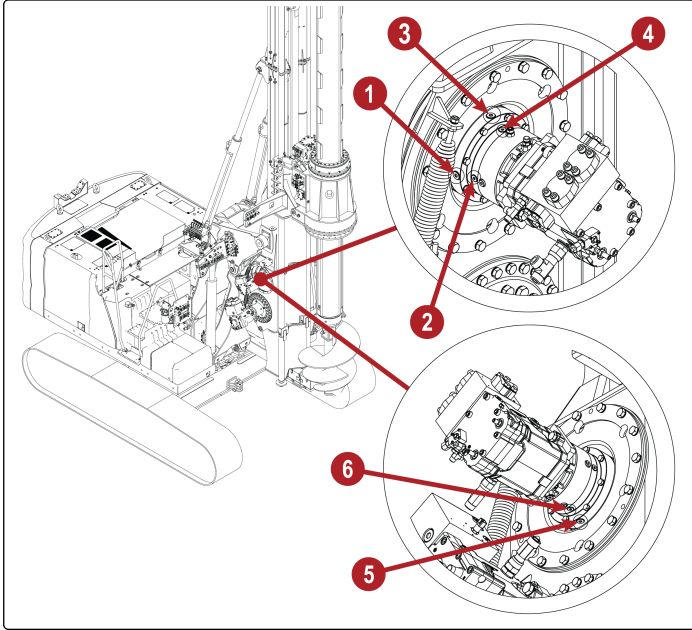

12.14. ROTARY MAINTENANCE

12.14.1. Rotary Reducer

12.14.1.1. Checking the Rotary Reducer Oil

1. Place the mast in the vertical operating position (leveled).
2. Position the rotary all the way to the bottom of the mast.
3. Remove any tooling attached to the kelly bar. See [Section: "Disconnect the Work Tool "](#) (page 361) for more information.
4. Wait 2 minutes for the oil to settle before checking the level.
5. Prepare the machine for service. For more information refer to [Prepare the Machine for Maintenance*](#) (page 384).
6. Remove the drain/fill/level plug (1).

The oil level should be at the bottom of the plug hole.

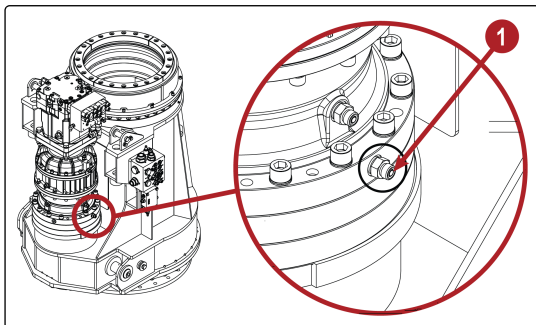

7. If the oil level is low, add oil.
See [Section: "Adding the Rotary Reducer Oil "](#) (page 516) for more information.
8. If more than one reducer is equipped, repeat the procedure for all reducers.

12.14.1.2. Adding the Rotary Reducer Oil

1. Place the mast in the vertical operating position (leveled).
2. Position the rotary all the way to the bottom of the mast.
3. Remove any tooling attached to the kelly bar. See [Section: "Disconnect the Work Tool "](#) (page 361) for more information.
4. Prepare the machine for service. For more information refer to [Prepare the Machine for Maintenance*](#) (page 384).
5. Remove the top overflow plug (2).

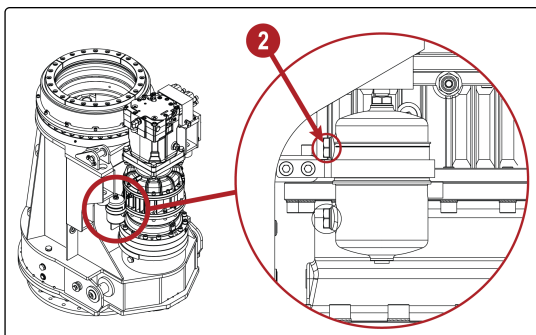

6. Remove the drain/fill/level plug (1).
7. Add oil through the drain/fill/level plug (1) hole until the level is at the bottom of the hole.

Refer to *Fluids and Lubricants (page 400)* for more information.

8. Clean the plugs and inspect the seals, if damaged, replace the plug or seal.
9. Make sure all removed plugs are installed and tightened.
10. If more than one reducer is equipped, repeat the procedure for all reducers.

12.14.1.3. Draining and Refilling the Rotary Reducer Oil



ENVIRONMENTAL NOTICE

- Make sure that fluids are contained while performing inspection, maintenance, testing, adjusting, and repairs on the machine.
- Be prepared to collect any fluids with suitable containers before opening any lines or components containing fluids.
- Dispose of all fluids according to local regulations and mandates.
- Contact the CZM After Sales Department for tools and supplies suitable to collect and contain fluids on CZM products.

Improper waste disposal can harm the environment.

1. Operate the rotary without any load for about 5 minutes to warm up the oil.
2. Position the rotary all the way to the bottom of the mast.
3. Remove any tooling attached to the kelly bar. See *Section: "Disconnect the Work Tool" (page 361)* for more information.
4. Place the mast in the transport (horizontal) position.

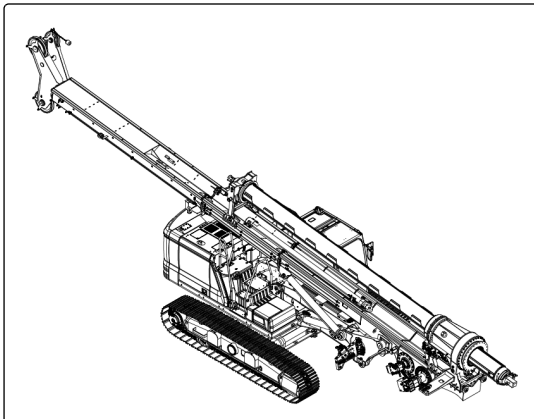

5. Prepare the machine for service. For more information refer to *Prepare the Machine for Maintenance* (page 384)*.
6. Remove the overflow plugs (2).

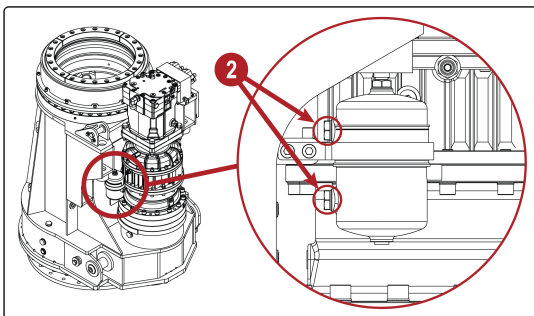

7. Remove reducer drain/fill/level plug (1), and most old oil will flow out.

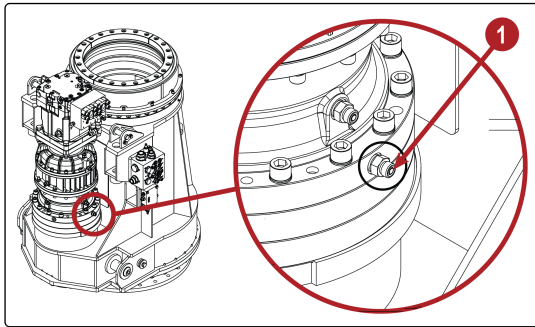

8. Using a flexible hose that fits in the port, pump the remaining oil out (make sure the hose being used is clean and no debris is left inside).
9. Clean the plugs and inspect the seals, if damaged, replace the plug or seal.
10. Check the drained oil for metal chips or particles. If there are any chips or particles, contact CZM After Sales Department
11. Place the mast back in the vertical operating position.

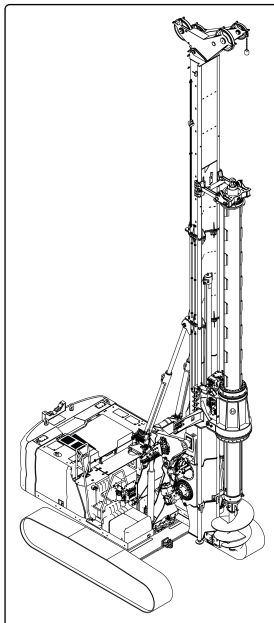

12. Add the new oil through the same reducer drain/fill/level plug hole (1) used to drain the rotary reducer. When oil is at the bottom of the hole, it is full.
Refer to *Fluids and Lubricants (page 400)* for more information.
13. Make sure all removed plugs are installed and tightened.
14. If more than one reducer is equipped, repeat the procedure for all reducers.

12.14.2. Rotary Casing

12.14.2.1. Checking the Rotary Casing Oil

1. Place the mast in the vertical operating position (leveled).
2. Position the rotary all the way to the bottom of the mast.
3. Lower the work tool to the ground.
4. Make sure there is no suspended load.
5. Wait 2 minutes for the oil to drain down.

6. Prepare the machine for service. For more information refer to [Prepare the Machine for Maintenance*](#) (page 384).
7. Check the oil level at the sight glass (1). The oil level should be in the middle of the sight glass.
If there is a plug, remove the plug.
The oil level should be at the bottom of the plug hole.

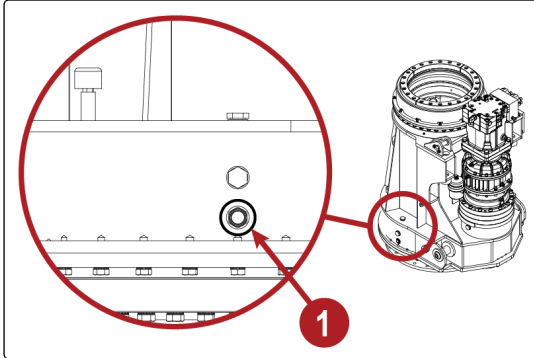

8. If the oil level is low, add oil.
See [Section: "Adding the Rotary Casing Oil"](#) (page 519) for more information.

12.14.2.2. Adding the Rotary Casing Oil

1. Operate the rotary without any load for about 5 minutes to warm up the oil.
2. Place the mast in the vertical operating position (leveled).
3. Position the rotary all the way to the bottom of the mast.
4. Lower the work tool to the ground.
5. Make sure there is no suspended load.
6. Prepare the machine for service. For more information refer to [Prepare the Machine for Maintenance*](#) (page 384).
7. Remove the breather plug (3).
8. Remove the top fill plug (2).
9. Add new oil until the level is in the middle of the sight glass (1).
If there is a plug, remove the plug and add oil until the level is at the bottom of the plug hole.
Refer to [Fluids and Lubricants](#) (page 400) for more information.
10. Install and tighten all removed plugs.

Figure 266.

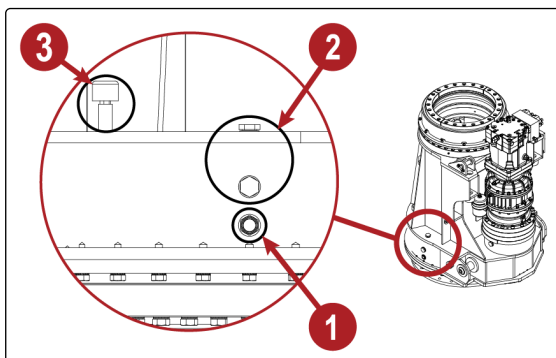

0000285 Rotary Head-Casing Adding Oil Procedure

Pos.	Description
1	Sight Glass/Level Plug

Pos.	Description
2	Fill Plug (Qty 2)
3	Breather Plug

12.14.2.3. Draining and Refilling the Rotary Casing Oil

ENVIRONMENTAL NOTICE

- Make sure that fluids are contained while performing inspection, maintenance, testing, adjusting, and repairs on the machine.
- Be prepared to collect any fluids with suitable containers before opening any lines or components containing fluids.
- Dispose of all fluids according to local regulations and mandates.
- Contact the CZM After Sales Department for tools and supplies suitable to collect and contain fluids on CZM products.

Improper waste disposal can harm the environment.

1. Operate the rotary without any load for about 5 minutes to warm up the oil.
2. Place the mast in the vertical operating position (leveled).
3. Position the rotary all the way to the bottom of the mast.
4. Lower the work tool to the ground.
5. Make sure there is no suspended load.
6. Prepare the machine for service. For more information refer to *Prepare the Machine for Maintenance** (page 384).
7. Remove the breather plug (3).

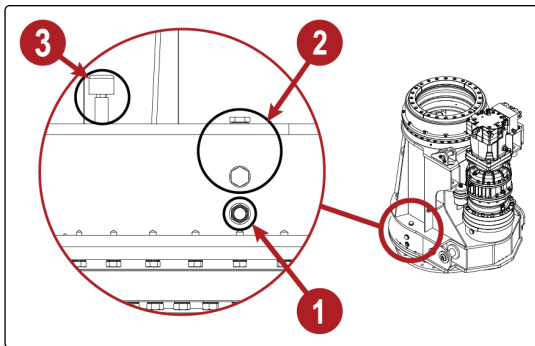

8. Remove the drain plug (4) and drain the old oil.

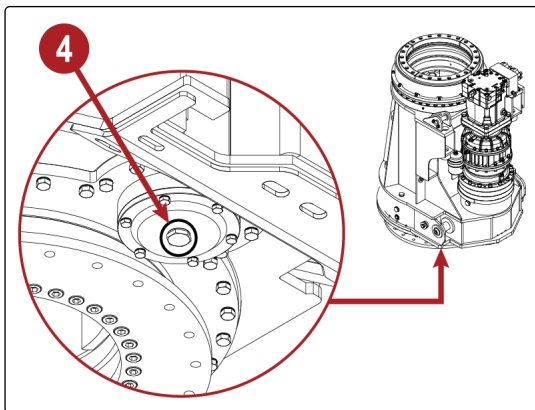

9. Check the drained oil for metal chips or particles. If there are any chips or particles, contact CZM After Sales Department
10. Clean the plugs and inspect the seals, if damaged, replace the plug or seal.
11. Remove the top fill plug (2) and add the new oil through it.
Refer to *Fluids and Lubricants (page 400)* for more information.
12. Stop filling when the oil level is in the sight glass's middle. If there is a level plug instead of a sight glass, remove it and add oil until the level is at the bottom of the plug hole.
13. Wait 1 minute for the oil to drain down and recheck the oil level.
14. Install and tighten all removed plugs.

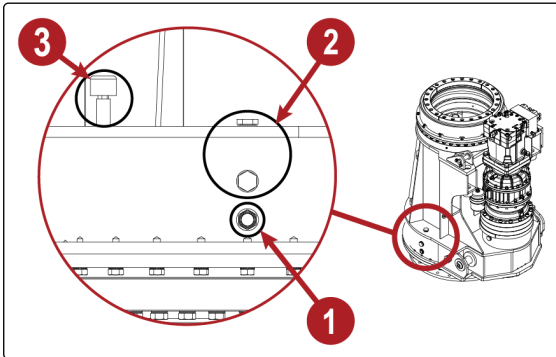

12.14.3. Rotary Sled Wear Pads

12.14.3.1. Adjusting the Rotary Sled Wear Pads

The rotary head wear pads have an adjustment to reduce slack caused by the wear of the plastic material. Adjust the sheets as follows.

1. Loosen the lock nuts (3) and use the adjusting screws (4) to adjust the side (1) and back (2) wear pads.
2. Make sure all screws are equally tensioning the plates.
3. Lock the screws (4) in place again using the nuts (3).

Figure 267.

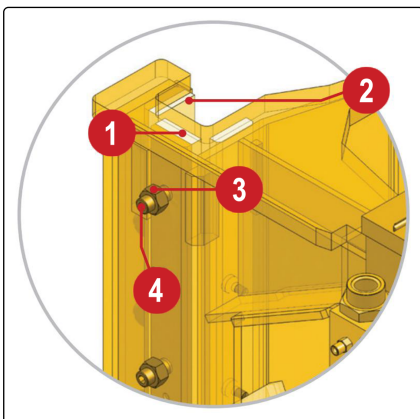

0000204 Rotary Head-Sled Wear Pad Adjustment Procedure

POS.	DESCRIPTION
1	Side Wear Pad

POS.	DESCRIPTION
2	Back Wear Pad
3	Lock Nut
4	Adjusting Screw

12.14.3.2. Removing the Rotary Sled Wear Pads

1. Remove the rotary head.
See [Section: "Disassembling the Rotary" \(page 343\)](#) for more information.
2. Remove set screws (3).
3. Remove front/back wear pads (4).

Figure 268.

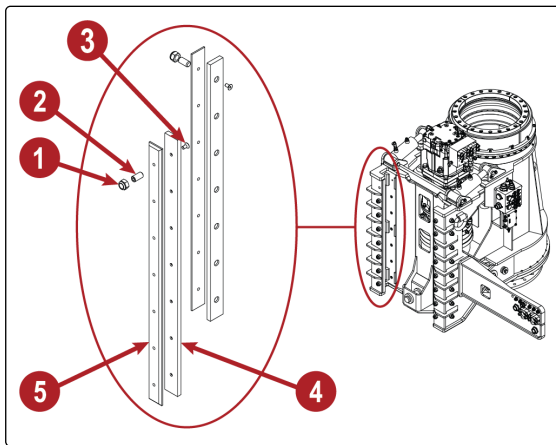

0000361 Rotary Head-Sled Wear Pad Removal-Installation Procedure

POS.	DESCRIPTION
1	Nylon Lock Nut
2	Adjusting Screw
3	Set Screw
4	Front/back Wear Pad
5	Adjustment Plate

12.14.3.3. Installing the Rotary Sled Wear Pads

1. Install the new wear pad and secure it with set screws (3).
2. Adjust the new wear pad so there is adequate clearance when installing the rotary head on the mast.
3. Remove the rotary head.
See [Section: "Disassembling the Rotary" \(page 343\)](#) for more information.
4. Adjust the wear pads.
See [Section: "Adjusting the Rotary Sled Wear Pads" \(page 521\)](#) for more information.

Figure 269.

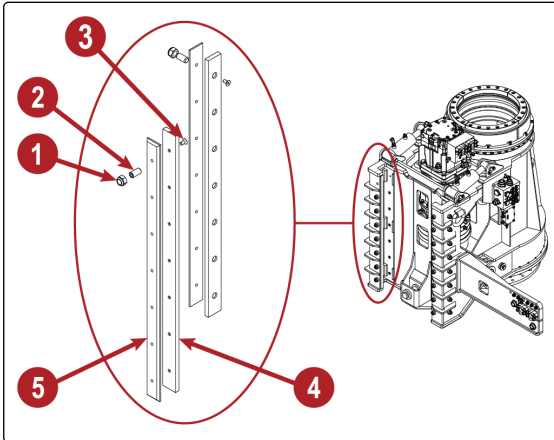

0000361 Rotary Head-Sled Wear Pad Removal-Installation Procedure

POS.	DESCRIPTION
1	Nylon Lock Nut
2	Adjusting Screw
3	Set Screw
4	Front/back Wear Pad
5	Adjustment Plate

12.15. A-FRAME MAINTENANCE

⚠ WARNING
 The A-frame maintenance must be performed with the A-frame at ground level.
 Failure to follow this warning could result in death or serious injury.

12.15.1. Replacing the A-frame Wear Pads

Wear pads (1) allow the A-frame to slide across the mast. Each wear plate is retained by screws.

Figure 270.

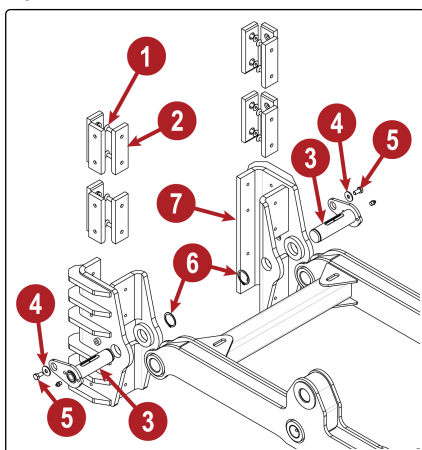

0000340 A-Frame-Wear Pad Replacement Procedure

Pos.	Description
1	Set Screw
2	Wear Pad
3	Pin
4	Washer
5	Bolt
6	Snap Ring
7	A-Frame Foot

1. Prepare the machine for service. For more information refer to *Prepare the Machine for Maintenance** (page 384).
2. Place the mast in the transport (horizontal) position.
3. Remove the snap ring (6) from the pin (3).
4. Remove the bolt (5) and washer (4) securing the pin.
5. Remove the pin and A-frame foot (7).
6. Remove the screws (1) securing the wear pads (2).
7. Install the new wear pads.
8. Position the A-frame foot on the mast and align it with the mounting hole on the A-frame.
9. Install the pin and secure it with the bolt and washer.
10. Install the snap ring on the pin.

12.16. TORQUE SPECIFICATIONS

Unless otherwise specified, fasteners should be tightened in a cross pattern.

Use the following procedure, unless the tightening sequence is specified:

1. Hand-tighten all fasteners. Larger fasteners may require the use of a small hand wrench.
2. Torque all fasteners to 40% of full torque.
3. Torque all fasteners to 70% of full torque.
4. Torque all fasteners to full torque by using a cross pattern. Large flanges may require additional passes.
5. Apply at least one final full torque to all fasteners in a clockwise direction until all torque is uniform. Large flanges may require additional passes.

Note: Final torque may be a turn.



IMPORTANT

- Be sure to use a torque wrench that has the proper range.
- Torque wrenches must be used properly in order to ensure that the correct torque is applied.
- Always use a smooth pull for torque wrenches.
- Do not jerk a torque wrench.
- Do not use adapters that change the length of the torque wrench.
- For the correct use of your torque wrench, refer to the instructions that were packaged with your torque wrench.



WARNING

- Prior to installation of any hardware, ensure that components are in near-new condition.
- Bolts and threads must not be worn or damaged.
- Threads must not have burrs or nicks.
- Hardware must be free of rust and corrosion.
- Clean reused fasteners with a noncorrosive cleaner.

Failure to follow this warning could result in death or serious injury.



CAUTION

- Too much tension on the bolt will cause the bolt to be stretched beyond the point of yield. The bolt will be permanently stretched and will loosen the grip on the parts that are being fastened. If the bolt is tightened again, the bolt will break.
- Do not reuse bolts that have been permanently stretched.
- All sealants and lubricating compounds must be removed (and reapplied where applicable) before reusing bolts.

The torque table below must be used as a general guideline for approximate bolt torques. Exact values depend on the application, fastened materials, and many other variables. Exceptions and specific torques are reported in their respective procedures. Bolt torques in the table below apply to steel fasteners as per ISO (formerly DIN), values are based on the VDI2230 standard.

CZM recommends the assembly methods below, reported torques are based on the resulting friction coefficients from these assembly methods.

CZM recommends Loctite Red 262 thread locker.

Fastener Size	Assembly Method
M5-M8	Dry assembly
M10-M48	Oil lubricated /thread lock and anti-seize

Table 73. Tightening Torque Values for Standard Metric Fasteners

Fastener Size	Metric Grade 8.8		Metric Grade 10.9		Metric Grade 12.9	
	N•m	lb-ft	N•m	lb-ft	N•m	lb-ft
M 5 ^a	6 ± 2	4 ± 1	8,5 ± 2	6 ± 2	10,2 ± 3	8 ± 2
M 6 ^a	10,5 ± 3	8 ± 2	14,5 ± 4	11 ± 3	17,5 ± 4	13 ± 3
M 8 ^a	25 ± 6	18 ± 5	35 ± 9	26 ± 6	42 ± 11	31 ± 8
M 10	41 ± 7	30 ± 5	57 ± 10	42 ± 8	69 ± 12	51 ± 9
M 12	70 ± 13	52 ± 9	99 ± 18	73 ± 13	119 ± 21	88 ± 16
M 14	112 ± 20	83 ± 15	157 ± 28	116 ± 21	189 ± 34	139 ± 25
M 16	170 ± 26	125 ± 19	240 ± 36	177 ± 27	285 ± 43	210 ± 32
M 18	235 ± 35	173 ± 26	330 ± 50	244 ± 37	395 ± 59	292 ± 44
M 20	330 ± 50	244 ± 37	465 ± 70	343 ± 51	560 ± 84	413 ± 62
M 22	445 ± 56	328 ± 41	625 ± 78	461 ± 58	755 ± 94	557 ± 70
M 24	570 ± 71	421 ± 53	800 ± 100	590 ± 74	965 ± 121	712 ± 89
M 27	840 ± 105	620 ± 77	1180 ± 148	871 ± 109	1420 ± 178	1048 ± 131
M 30	1140 ± 143	841 ± 105	1610 ± 201	1188 ± 149	1930 ± 241	1424 ± 178
M 33	1540 ± 193	1137 ± 142	2170 ± 271	1601 ± 200	2600 ± 325	1919 ± 240
M 36	1990 ± 249	1469 ± 184	2790 ± 349	2059 ± 257	3350 ± 419	2472 ± 309
M 39	2570 ± 257	1897 ± 190	3610 ± 361	2664 ± 266	4330 ± 433	3196 ± 320
M 42	3193 ± 319	2356 ± 471	4487 ± 449	3312 ± 331	5382 ± 538	3972 ± 397
M 45	3994 ± 399	2947 ± 589	5610 ± 561	4140 ± 414	6731 ± 673	4968 ± 497
M 48	4817 ± 482	3555 ± 711	6778 ± 678	5002 ± 500	8120 ± 812	5993 ± 599

^aDry Assembly

12.17. O-RING SPECIFICATIONS

O-Ring Face Seal (ORFS) fittings incorporate an O-ring at the face of the fitting to prevent leaks in high-pressure hydraulic systems.

Figure 271.

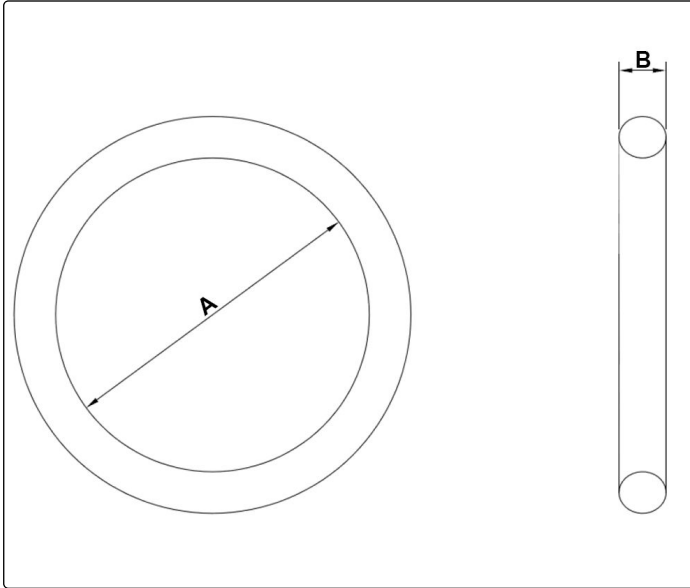

0000211 O-Ring Specifications

Use the following table for replacing the O-ring face seal fittings.

Table 74. O-Ring Specifications

Parker Hydraulics ID #	DASH Size #	Thread Size	"A" Dimension	"B" Dimension
2-011	4	9/16 in. - 18	7.65 mm (0.30 in.)	1.78 mm (0.7 in.)
2-012	6	11/16 in. -16	9.25 mm (0.36 in.)	1.78 mm (0.7 in.)
2-014	8	13/16 in. -16	12.42 mm (0.49 in.)	1.78 mm (0.7 in.)
2-016	10	1 in. -14	15.60 mm (0.61 in.)	1.78 mm (0.7 in.)
2-018	12	1 3/16 in. -12	18.77 mm (0.74 in.)	1.78 mm (0.7 in.)
2-021	16	1 7/16 in. -12	23.52 mm (0.93 in.)	1.78 mm (0.7 in.)
2-025	20	1 11/16 in. -12	29.87 mm (1.18 in.)	1.78 mm (0.7 in.)
2-029	24	2 in. -11	37.82 mm (1.49 in.)	1.78 mm (0.7 in.)

12.18. HYDRAULIC PRESSURE SPECIFICATIONS



WARNING

Hydraulic relief valves limit system pressure to protect components.

All hydraulic system relief valves work by balancing the hydraulic force with an adjustable spring force.

- The hydraulic valves may only be adjusted by qualified personnel.
- The hydraulic system must be depressurized before work can be performed on the system.
- If valves are not set properly or monitored carefully using proper gauges, the hydraulic system can malfunction and be damaged.

Failure to follow this warning could result in death or serious injury.

Use the following table to check and set hydraulic system pressures.

Table 75. Hydraulic Pressure Specifications

Component	Pressure (bar)	Pressure (psi)
Pilot System Pressure (Maximum)	40	580
Auxiliary Hydraulic Pump Pressure (Maximum)	320	4600
Main Hydraulic Pump Pressure (Maximum)	350	5000
Tilt Cylinders	310-317	4500-4600
Boom Cylinders	310-317	4500-4600
Rotary Pressure	345-352	5000-5100
Main Winch Maximum Pressure	345-352	5000-5100
Crowd Cylinder Up Pressure	310-317	4500-4600
Crowd Cylinder Down Pressure	262-276	3800-4000
Undercarriage	303-317	4400-4600
Mast Transport Functions (Masthead Cylinder, Detent, and Rotary Cylinder)	195-205	2830-2975

13. INDEX

A

A-Frame

- Assembly, 327
- Description, 47
- Detent Lock/Unlock, 222
- Disassembly, 341
- Wear Pads Replacement, 524

After-Sales

- Contacts, 21

Air Conditioning

- Control, 244
- Filter Inspection and Replacement, 477

Alarm

- Swing Alarm Switch, 225
- Travel Alarm Mute Switch, 207
- Travel Alarm Test, 496

Auto Crowd

- Activation, 212
- Depth Setting, 215

Auxiliary Winch

- Description, 50
- Limit and Exclusion Switch, 218
- Limits of Use, 174
- Lowering Control, 199
- Raising Control, 199
- Reducer/Brake Oil Adding, 513
- Reducer/Brake Oil Draining and Refilling, 514
- Reducer/Brake Oil Level Check, 512
- Safety, 105
- Stability-Forward Facing Tilted (Standard Mast), 148
- Stability-Off The Side Tilted (Short Mast), 160, 162
- Stability-Off The Side Tilted (Standard Mast), 150
- Technical Data, 127
- Wire Rope Maintenance, 506

B

Base

- Description, 39
- Maintenance, 414

Battery

- Disconnect Switch, 186
- Icon (CZM Monitor), 210
- Maintenance, 467
- Maintenance (Safety), 117
- Safety (Burn), 87
- Safety (Fire and Explosion), 89

Belt

- Maintenance, 432

C

Cab

- Controls Overview, 189
- Description, 41
- Dome Light, 254
- Door Operation, 250
- Emergency Exit, 102
- Maintenance, 477

Cameras

- 360 Visibility Camera Description, 260
- Maintenance, 469
- Rear View Camera Description, 259
- Right Side View Camera Description, 259

Casing

- Installation, 312

Center of Gravity

- Transportation, 376

Condenser

- Cleaning, 478

Conversions, 347

- Components' Weight, 348
- From Short to Standard Mast, 353
- From Standard to Short Mast, 349

Coolant

- Adding, 429
- Change, 427
- Level Check, 430
- Sample Obtaining (Level 1), 430
- Sample Obtaining (Level 2), 431

Counterweight

- Assembly of the CAT Counterweight (Main), 322
- Assembly of the CZM Counterweight (Additional), 321
- Description, 38
- Disassembly of the CAT Counterweight (Main), 345
- Disassembly of the CZM Counterweight (Additional), 344
- Weight, 128

Crowd

- Auto Crowd Control, 204
- Auto Crowd Master Enable, 229
- Auto Crowd Operation, 306
- Auto Crowd Tilt Limit, 230
- Crowd Control, 203
- Crowd Force Indicator, 211
- Description of the Crowd Cylinder, 48
- Over Crowd Warning, 210
- Pressure Adjustment, 215
- Pull Up Control, 203
- Speed Adjustment, 215
- Technical Data of the Crowd Cylinder, 122

CZM Monitor, 209

- Password, 226

D

Decommissioning, 319

Depth

Reset, 212

Short Mast, 122

Standard Mast, 122

Disposal, 319

Doors

Access Door and Hood Locations, 381

Engine Service Door, 382

Left Front Access Door, 382

Left Rear Access Door, 382

Right Front Access Door, 383

Right Side Access Door, 382

Drilling

Automatic Drilling Control, 203

Automatic Drilling Functions, 306

Rock (Boulders), 311

Slurry/Polymer or Bentonite, 312

Standard Operation, 303

Drilling Rig

Access, 100

Dimensions (Short Mast), 134

Dimensions (Standard Mast), 130

Improper Use, 29

Intended Use, 28

Leaving the Machine, 317

Optional Uses, 29

Workplace, 101

E

Engine

Air Filter Maintenance, 420

Belt Maintenance, 432

Shutdown Switch, 316

Start Switch Description, 196

Starting Procedure, 286

Stopping Procedure, 315

Technical Data, 128

Engine Oil

Filter Change, 416

Level Check, 414

Oil Change, 416

Sample Obtaining, 416

Environment

Safety Limits, 182

F

Faults

Active Faults List (CZM Monitor), 231

Filters

- Air Conditioner/Cab Heater Filter Inspection and Replacement, 477
- Cab Air Filter Cleaning and Replacement, 479
- Engine Air Filter Maintenance, 420
- Fuel System, 433
- Hydraulic Oil Filter Inspection, 465
- Hydraulic Oil Filter Replacement, 459
- Return Filters Replacement, 467

Fire Extinguisher

- Location, 90

Frame

- Maintenance, 487

Fuel System

- Refueling Operation, 261

Fuses

- Description, 472
- Replacement, 471

G

Gauges

- Description, 188

Grease

- Cold Temperature, 404
- Hot Weather, 404
- Regular Ambient Temperature, 403

Ground Pressure, 139

H

Hazards, 79

- Burn*, 86
- Chemicals, 93
- Crushing and Cutting*, 85
- Dust, 93
- Electrical Storm Injury*, 92
- Explanation of Symbols, 23
- Fire and Explosion*, 87
- Health and First Aid, 79
- Inhalation*, 84
- Pressurized Lines*, 80
- Snow and Ice, 93
- Suspended Loads and Falling Objects, 94

Heating

- Control, 244

Hoods

- Access Door and Hood Locations, 381
- Engine Hood, 381

Horn

- Control, 202

Humidity

- Operative Range, 182

Hydraulic System

- Air Purging, 456
- Oil Changing, 451
- Oil Filling, 456
- Oil Level Check, 462
- Pressure Specifications, 528
- Technical Data, 128

J

Joysticks

- Left Joystick Controls Description, 201
- Right Joystick Controls Description, 203

K

Kelly Bar

- Assembly, 328
- Description, 53
- Disassembly, 335
- Lock for Transportation, 368
- Safety, 106
- Technical Data (Short Mast), 122
- Technical Data (Standard Mast), 122

L

LED Lamps

- Replacement, 477

Levers

- Controls Description, 199

Lights

- Mast Lights Activation, 213

Lubrication

- Lubrication Points and Recommendations, 406

M

Main Winch

- Auto-Shift Control, 202
- Auto-Shift Mode Selection, 224
- Auto-Shift Operation, 309
- Description, 49
- Downshift Mode Selection, 224
- Force Indicator, 210
- Full Layers Selection, 230
- Last Layer Wraps Selection, 230
- Limit and Exclusion Switch, 217
- Low-Speed Control, 202
- Lowering Control, 201
- Maintenance, 508
- Raising Control, 201
- Reducer/Brake Oil Adding, 509
- Reducer/Brake Oil Draining and Refilling, 510
- Reducer/Brake Oil Level Check, 508

- Speed Adjustment, 215
- Technical Data, 126
- Wire Rope Maintenance, 506
- Maintenance
 - Access Door and Hood Locations, 381
 - Fluids Type, 400
 - Frame, 487
 - LED Lamps Replacement, 477
 - Lubricants Quantities, 406
 - Lubricants Type, 400
 - Lubrication Points, 406
 - Machine Preparation, 384
 - Main Winch, 508
 - Oil Quantities, 406
 - Plan, 386
 - Safety, 114
 - Upper Frame, 489
 - Welding Recommendations, 379
 - Welding Safety Precautions, 115
- Manual
 - About, 22
 - Code, 20
 - Use and Purpose, 22
- Manufacturer
 - About, 21
 - Contacts, 21
- Mast
 - Automatic Leveling Control, 201
 - Description, 45
 - Inclination Safety Limits, 181
 - Left Tilting Control, 200
 - Level Calibration, 225
 - Lowering Control, 200
 - Raising Control, 200
 - Raising/Lowering Safety Limits, 180
 - Right Tilting Control, 200
- Mast Head
 - Description, 47
 - Folding Control, 222
- Mirrors
 - Adjustment, 256
 - Description, 255
- Monitors
 - CAT Monitoring System, 232
 - CZM Monitor, 209
- O**
- O-Ring
 - Specifications, 527
- Oil
 - Cold Temperature, 404

Hot Weather, 404
Regular Ambient Temperature, 403

P

Parallelogram
Description, 43
Lowering Control, 199
Operation Information, 264
Raising Control, 199
Parking, 315
Personal Protective Equipment (PPE), 69
Plates
Identification Plate, 32
Power Lines
Distance, 95
Safety, 95
Pressures
Specifications, 528
Pumps
Fuel Pump Operation, 261
Gauges, 188

R

Relays
Description, 474
Rotary
Auto Power Shift Master Enable, 230
Auto Power Shift Operation, 309
Auto-Shift ON/OFF Selection, 224
Auto-Shift Operation, 308
Casing Oil Adding, 519
Casing Oil Check, 518
Casing Oil Draining and Refilling, 520
Description, 51
Dimensions, 138
Gear Indicator, 211
Power Shift Indicator, 211
Power Shift Mode Selection, 224
Pressure Adjustment, 215
Reducer Oil Adding, 516
Reducer Oil Check, 516
Reducer Oil Draining and Refilling, 517
Rotation Control-Clockwise, 203
Rotation Control-Counterclockwise, 203
RPM Indicator, 211
Sled Wear Pads Adjustment, 521
Sled Wear Pads Installation, 522
Sled Wear Pads Removal, 522
Speed Adjustment, 215
Speed Control, 204
Spin-Off Control, 204

Technical Data (Optional), 125
Technical Data (Standard), 123
Tilt Cylinders Control, 222
Torque Indicator, 211

S

Seat
 Adjustment and Operation, 192
 Belt Inspection, 480
 Belt Operation, 193
 Belt Replacement, 481
 Description, 191
Serial Number
 Machine, 20
 Position, 32
Setup
 Machine Setup for Drilling, 295
Shipment, 370
Slopes
 Traveling Down Hill, 177
 Traveling Up Hill, 176
 Traversing, 178
Sound
 Level, 173
Stability, 139
 Short Mast, 152
 Standard Mast, 140
Storage, 318
Swing
 Camera Activation, 212
 Control-Clockwise, 201
 Control-Counterclockwise, 201
 Control-Return To Center, 202
 Hole Center Function, 212
 Lubrication of the Bearing, 490
 Lubrication of the Gear, 493
 Oil Change, 490
 Oil Level Check, 492
 Oil Sample Obtaining, 492
 Operation Information, 264
 Safety Limits, 179
Swivel
 Assembly, 326
 Disassembly, 342
Symbols
 Description, 64

T

Temperature
 Operative Range, 182
Tool

- Connection, 301
- Disconnection, 361
- Torque
 - Specifications, 525
- Transportation
 - Center of Gravity, 376
 - Dimensions (Short Mast), 137
 - Dimensions (Standard Mast), 133
 - Lifting, 375
 - Safety, 112
 - Securing the Machine, 372
 - Shipment, 370
 - Technical Data, 129
 - Tying Down, 373
 - Weight, 129

U

- Undercarriage
 - Alarm Test, 496
 - Check, 496
 - Description, 36
 - Extension Procedure, 297
 - Final Drive Oil Change, 502
 - Final Drive Oil Level Check, 504
 - Final Drive Oil Sample Collection, 505
 - Forward and Reverse Travel, 295
 - Opening/Closing Controls, 222
 - Operation Information, 263
 - Retraction Procedure, 369
 - Track Adjustment Inspection, 502
 - Track Tension Adjustment, 498
 - Track Tension Measurement, 497
 - Travel Controls, 197
 - Turning, 296
- Units of Measurement
 - Selection (CZM Monitor), 225

V

- Vibration, 173

W

- Warranty, 24
 - Exclusion Clause, 25
 - Machines, 24
 - Parts, 24
- Weight
 - Transportation, 129
- Weights
 - Components, 348
- Welding
 - Recommendations, 379

- Safety Precautions, 115
- Winches
 - Operation Information, 264
- Wind
 - Operative Conditions, 182
- Windows
 - Cleaning, 482
 - Front Window, 251
 - Roof Hatch, 253
 - Sun Screen, 253
 - Washer Reservoir Filling, 483
 - Wiper Inspection and Replacement, 483
- Wire Ropes
 - Specifications (Auxiliary Winch), 127
 - Specifications (Main Winch), 127
 - Wire Rope Inspection, 506
 - Wire Rope Lubrication, 506
 - Wire Rope Replacement, 506
- Work Area
 - Danger Zones, 164
 - Safety, 95

This page is intentionally left blank.
