

CZM

FOUNDATION EQUIPMENT



EK90M

Cat® 323 NG





MICRO-PILING APPLICATION

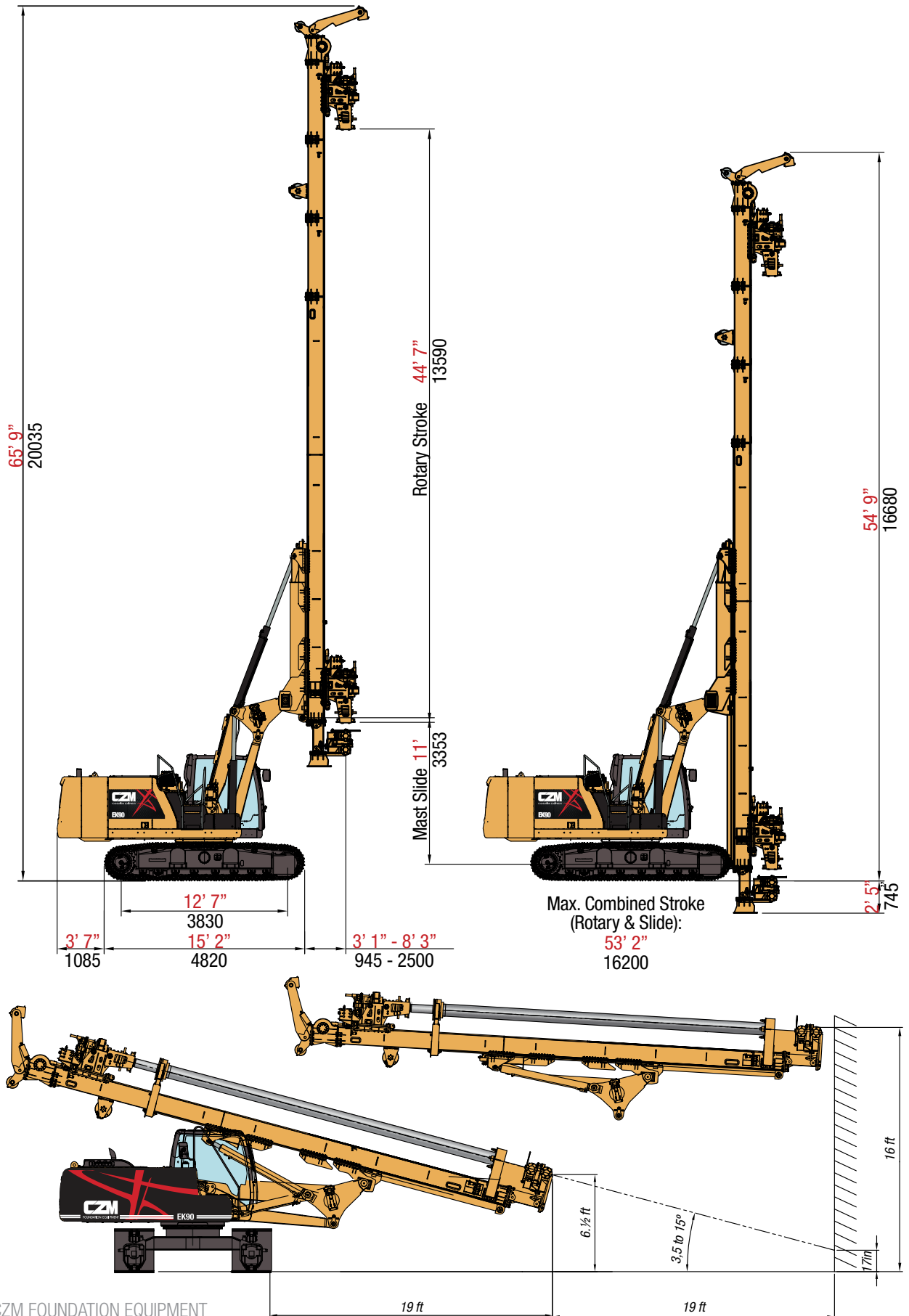

APPLICATIONS

CONTINUOUS FLIGHT AUGER

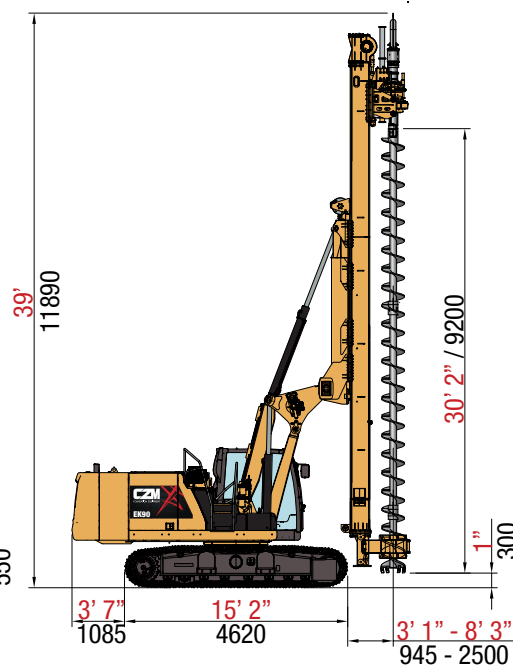
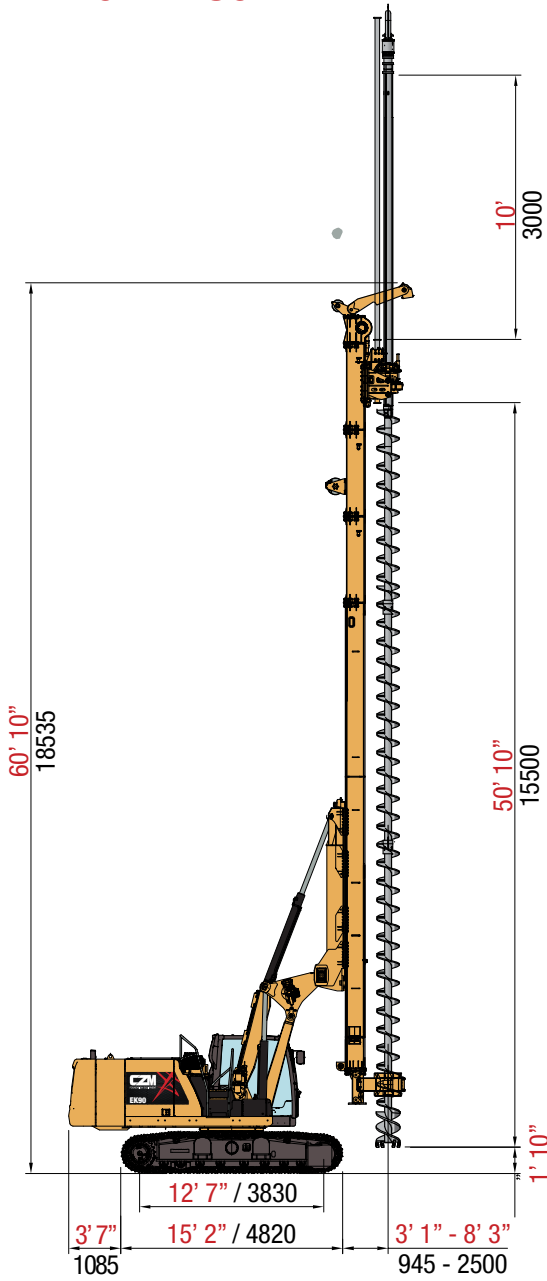

JET GROUTING

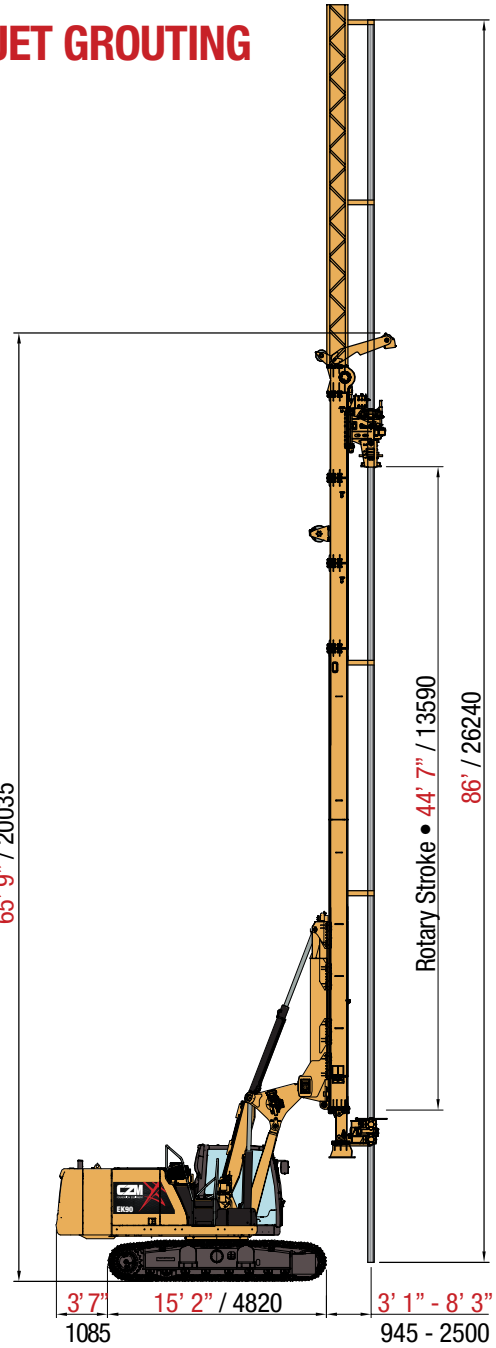

TRANSPORT POSITION

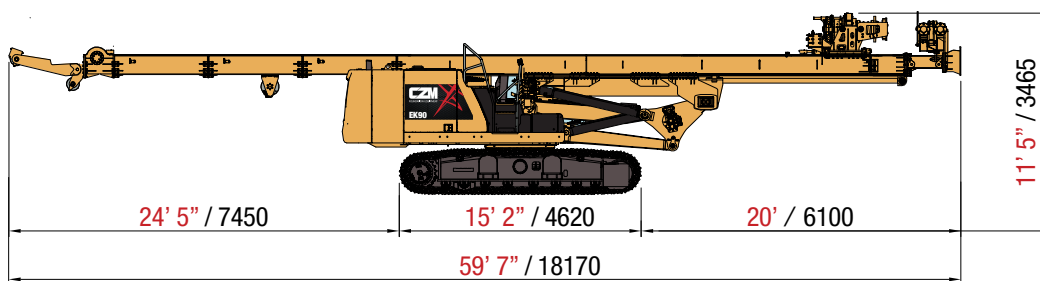

TECHNICAL SPECIFICATIONS

The CZM **EK90M** is a model designed to be a “Multifunctional Drill Rig” mounted on a Cat® 323 Next Gen TIER IV excavator base.

It can work for applications of Micropiles, Jet Grouting, Segmented Flight Auger, Interlocking Kelly Bar, CFA, Pile Driving and Tiebacks.

It is designed in a way that the conversion between these applications is simple. No major changes of hoses are necessary and it can be done in just a few hours.

For some applications it is equipped with a double tool feeder, one

on each side of the main mast. This allows drilling and extracting casings or augers without manhandling.

These versions are also equipped with radio remote control to a fast and safe operation.

Operation can be done either from the **remote control** or the cab.

The Parallelogram, the Mast Vertical Slide and the Rotary Shift Slide are great features, usefull for different processes of drilling operations.

MICRO PILE APPLICATION

Max. Diameter (Standard)	18 in	457.2 mm
Max. Diameter (Optional)	24 in	600 mm
Max. Single pass stroke	53 ft 2 in	16.2 m

CFA APPLICATION

Max. Diameter	24 in	600 mm
Max. Depth (20 in Diameter)	60 ft	18.2 m
Max. Depth (24 in Diameter)	45 ft	13.7 m

ROTARY HEAD - RT 640

Max. torque (nominal)	34,000 ft.lb	4,700 kgf
Working speed	21-118 rpm	
Side Shift Stroke	32 in	0.8 m

AUXILIARY WINCH

Max. pull-force - 1st Layer (effective)	6,600 lbf	3,000 kgf
---	-----------	-----------

MAST

Mast Length	57 ft 2 in	17,625 mm
Mast Slide	11 ft	3,353 mm
Stroke of rotary head	44 ft 7 in	13,590 mm
Total Stroke (Rotary + Mast Slide)	55 ft 7 in	16,943 mm
Crowd/Extraction force	44,300 lb	20,094 kgf
Feed speed	6 ft/min	1.8 m/min
Crowd speed (fast crowd)	12 ft/min	3.6 m/min

MAST INCLINATION

Backward	15°	15°
Forward	3°	3°
Sideways	9° / 9°	9° / 9°

DIESEL ENGINE Cat® 323 NEXT GEN (CAT® C7.1 ACERT™)

Net Power – Standard ISO 9249	172 hp	128 kW
Displacement	428 in3	7.01 L
Fuel Tank	86.6 gal	345 L

HYDRAULIC SYSTEM

Hydraulic pressure	5,076 psi	350 bar
Flow Rate (Main circuit)	2 x 56.5 gal / min	2 x 214.5 L/min
Flow Rate (Auxiliary circuit)	26.5 gal / min	100 L/min
Hydraulic Oil tank capacity	30.4 gal	115 L

UNDERCARRIAGE

Track length	15 ft 2 in	4,820 mm
Length to Center of rollers	12 ft 7 in	3,830 mm
Transport position width (retracted)	8 ft 4 in	2,560 mm
Work position width (extended)	11 ft 10 in	3,600 mm
Shoes width	23.6 in	600 mm
Max. Travel speed	1.93 mph	3.1 km/h

TRANSPORT

Transport height	11 ft 5 in	3,465 mm
Length	59 ft 7 in	18,170 mm
Transport width	9 ft	2,750 mm
Transport weight	72,500 lb	33,000 kg

DOUBLE CLAMPS

Max Diameter (standard)	18 in	457.2 mm
Max Diameter (optional)	24 in	600 mm

GENERAL DATA

Operating weight	72,500 lb	33,000 kg
------------------	-----------	-----------





FOUNDATION EQUIPMENT

THE COMPANY

CZM is headquartered in Savannah, Georgia, USA. For over 40 years, we have specialized in manufacturing foundation equipment. We design and customize models for many different drilling applications including Drill shafts, CFA/cased CFA, Micropile and anchoring, driven pile and hydraulic hammers and soil improvements. We are a Caterpillar OEM (Original Equipment Manufacturer).

HEADQUARTERS

962 Interstate Centre Boulevard
Ellabell • Georgia • 31308
United States • Phone: (912) 200-7654

AFTER SALES - CALIFORNIA

1720 N. Ventura Avenue
Ventura • California • 93001
United States • Phone: (805) 667-8416

AFTER SALES - GEORGIA

145 East Industrial Boulevard
Pembroke • Georgia • 31321
United States • Phone: (912) 200-7656

AFTER SALES - KENTUCKY

2001 West Hal Rogers Parkway
London • Kentucky • 40741
United States • Phone: (912) 320-2699

AFTER SALES - TEXAS

2501 Blue Mound Rd. W
Haslet • Texas • 76052
United States • Phone: (817) 232-8053

WWW.CZM-US.COM    